

US00D660790S

(12) **United States Design Patent**
Elison et al.

(10) **Patent No.:** **US D660,790 S**
(45) **Date of Patent:** **** May 29, 2012**

- (54) **BATTERY**
 - (75) Inventors: **Nicholas E. Elison**, Milwaukee, WI (US); **Glenn W. Andersen**, Hartford, WI (US)
 - (73) Assignee: **Johnson Controls Technology Company**, Holland, MI (US)
 - (**) Term: **14 Years**
 - (21) Appl. No.: **29/404,788**
 - (22) Filed: **Oct. 25, 2011**
 - (51) **LOC (9) Cl.** **13-02**
 - (52) **U.S. Cl.** **D13/106**
 - (58) **Field of Classification Search** D13/102-106, D13/110, 118-119, 184; 429/96-100, 149, 429/163, 176, 187
- See application file for complete search history.

- D303,373 S 9/1989 Ching, Jr.
- D303,519 S 9/1989 Lopez-Doriga
- D303,652 S 9/1989 Lopez-Doriga
- D303,653 S 9/1989 Lopez-Doriga
- D304,926 S 12/1989 Ching, Jr.
- D304,927 S 12/1989 Ching, Jr.
- 4,891,270 A 1/1990 Jergl et al.
- D307,133 S 4/1990 Ching, Jr.
- D307,886 S 5/1990 Ching, Jr. et al.
- D310,205 S 8/1990 Hedrington et al.
- D310,821 S 9/1990 Hulsebus et al.
- D318,025 S 7/1991 Moritaka
- D327,051 S 6/1992 Schwartz
- 5,283,137 A * 2/1994 Ching 429/175
- D344,676 S 3/1994 Newman
- D356,993 S 4/1995 Koster
- 5,415,956 A * 5/1995 Ching 429/187
- 5,440,785 A * 8/1995 McDonald 16/423
- D367,042 S 2/1996 Morrow
- 5,492,779 A * 2/1996 Ronning 429/120

(Continued)

OTHER PUBLICATIONS

Photographs of "old" Optima battery with a date stamp of Week 47, 1990.

(Continued)

Primary Examiner — Rosemary K Tarcza
(74) *Attorney, Agent, or Firm* — Boardman & Clark LLP

(56) **References Cited**

U.S. PATENT DOCUMENTS

- D64,969 S 6/1924 Glidden
- D67,258 S 5/1925 Bello
- D68,262 S 9/1925 Klug
- D70,400 S 6/1926 Campbell
- D75,446 S 6/1928 Rieser
- 2,724,360 A 11/1955 Crookshank
- D181,079 S * 9/1957 Slautterback D13/104
- D188,421 S 7/1960 Slautterback
- 3,105,909 A 10/1963 Jones
- D197,519 S 2/1964 Rohe
- D211,348 S 6/1968 Redmon
- D239,837 S 5/1976 Hennen
- 3,963,972 A 6/1976 Todd
- D252,354 S 7/1979 Uyeda
- 4,346,151 A 8/1982 Uba et al.
- D266,757 S 11/1982 Campbell et al.
- 4,510,215 A 4/1985 Adam
- 4,632,888 A * 12/1986 Kump et al. 429/187
- D292,576 S * 11/1987 Kump et al. D13/106
- D294,484 S * 3/1988 Kellett et al. D13/106
- 4,752,543 A * 6/1988 Anderson et al. 429/179
- D298,029 S 10/1988 Foster

(57) **CLAIM**
The ornamental design for a battery, as shown and described.

DESCRIPTION

FIG. 1 is a top isometric view of the battery according to an exemplary embodiment;
FIG. 2 is a first side elevation view thereof;
FIG. 3 is a first end elevation view thereof;
FIG. 4 is a second side elevation view thereof;
FIG. 5 is a second end elevation view thereof;
FIG. 6 is a top plan view thereof; and,
FIG. 7 is a bottom plan view thereof.

1 Claim, 7 Drawing Sheets

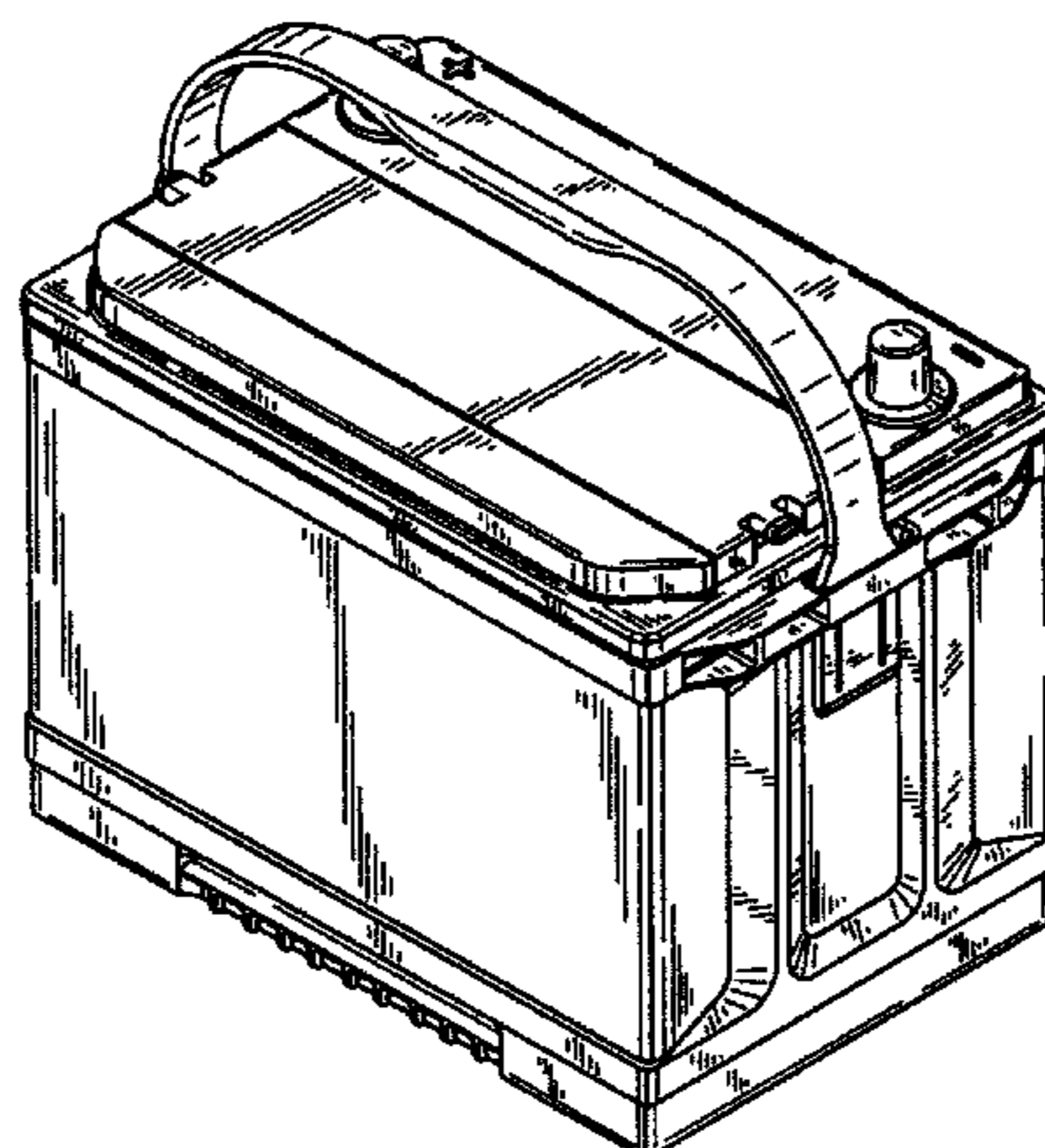

US D660,790 S

Page 2

U.S. PATENT DOCUMENTS

D372,701 S 8/1996 Tahmassebpur
5,599,641 A 2/1997 Ching, Jr. et al.
5,663,008 A * 9/1997 Shimakawa et al. 429/443
5,686,202 A 11/1997 Hooke et al.
5,763,116 A 6/1998 Lapinski et al.
D401,551 S * 11/1998 Kim D13/106
5,856,037 A 1/1999 Casale et al.
5,871,862 A 2/1999 Olson
D406,258 S 3/1999 Segers
5,895,728 A 4/1999 Walker et al.
5,977,746 A 11/1999 Hershberger et al.
5,998,062 A 12/1999 Olson
6,022,638 A 2/2000 Horton et al.
6,023,146 A 2/2000 Casale et al.
6,025,086 A 2/2000 Ching
6,153,331 A 11/2000 Brantley et al.
6,174,618 B1 1/2001 Nishiyama et al.
6,183,903 B1 2/2001 Campbell et al.
D442,542 S 5/2001 Dougherty et al.
6,303,247 B1 10/2001 Griffey et al.
D450,653 S 11/2001 Hertel et al.
D458,900 S * 6/2002 Carter et al. D13/106
6,399,238 B1 6/2002 Oweis et al.
D462,656 S 9/2002 Degen et al.
D466,478 S 12/2002 Bolstad et al.
D491,138 S 6/2004 Minato
D495,994 S 9/2004 Arakelian
D499,070 S 11/2004 Lavington
6,929,882 B1 8/2005 Carter
D517,479 S 3/2006 Schemm
D517,987 S 3/2006 Castagnola et al.
D517,988 S 3/2006 Ihde et al.
D527,344 S 8/2006 Rajpara et al.

D553,565 S 10/2007 Kawakita et al.
D562,229 S 2/2008 Peters
7,332,243 B2 2/2008 Cummins et al.
D600,202 S 9/2009 Mack
D606,938 S 12/2009 Mack
D606,939 S 12/2009 Mack
D606,940 S 12/2009 Mack
D607,405 S 1/2010 Mack
D607,406 S 1/2010 Mack
D607,407 S 1/2010 Mack
D608,283 S 1/2010 Mack
D609,178 S 2/2010 Mack
D609,179 S 2/2010 Mack
D609,631 S 2/2010 Mack
D610,089 S 2/2010 Mack
D614,126 S 4/2010 Chen
D621,353 S 8/2010 Mack
D625,253 S 10/2010 Mack
D625,254 S 10/2010 Mack
D633,866 S * 3/2011 Qualls et al. D13/106
D635,509 S 4/2011 Mack
D647,051 S * 10/2011 Qualls et al. D13/106
D647,052 S * 10/2011 Qualls et al. D13/106
2003/0059676 A1 3/2003 Rodriguez et al.
2004/0170888 A1 9/2004 Cummins et al.
2005/0069762 A1 3/2005 Daley et al.
2010/0136425 A1 * 6/2010 Gau et al. 429/187

OTHER PUBLICATIONS

Optima Batteries brochure entitled "The Ultimate Power Source" dated Mar. 2007.
Optima Batteries New Product Announcement, 2008.

* cited by examiner

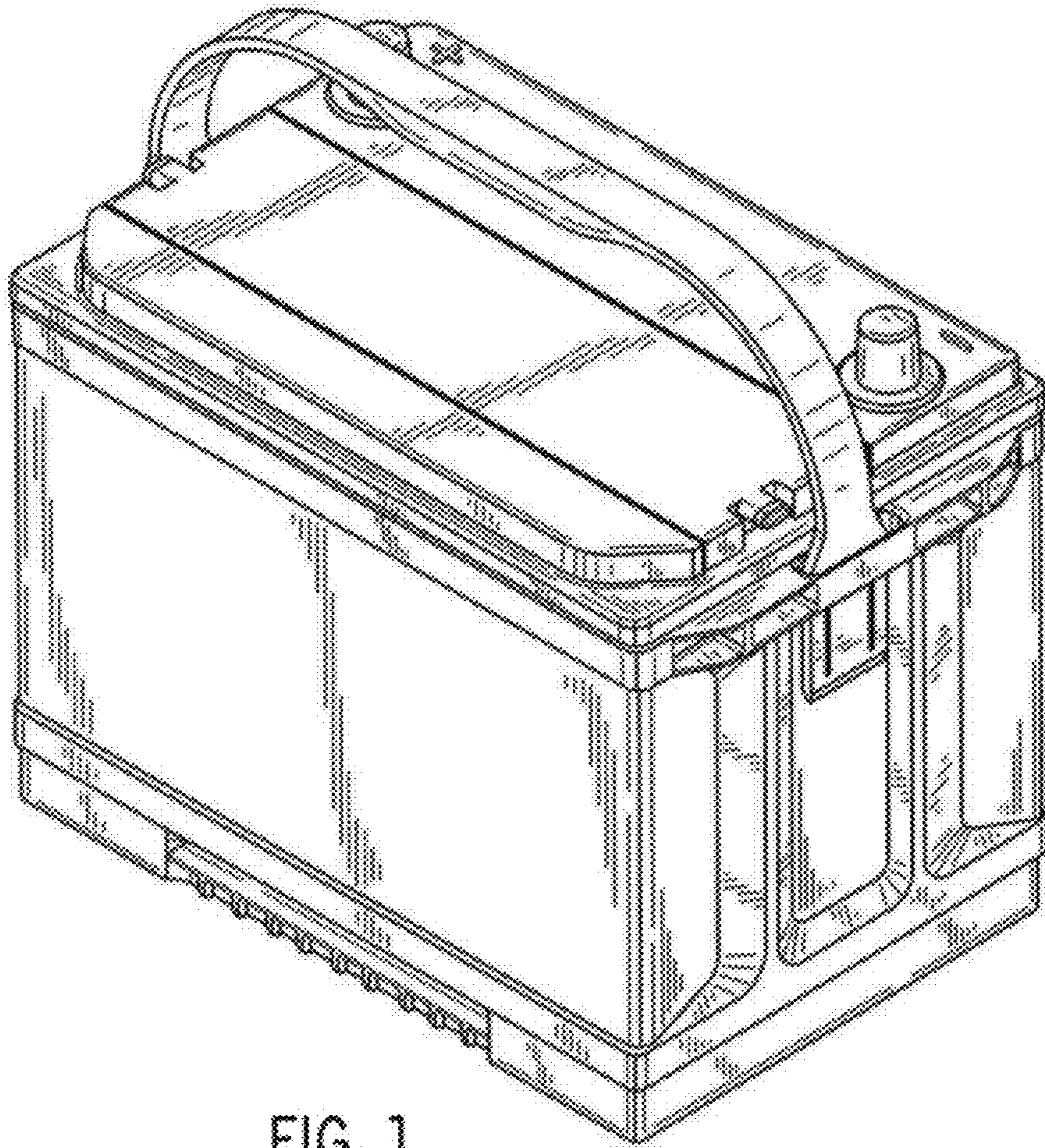

FIG. 1

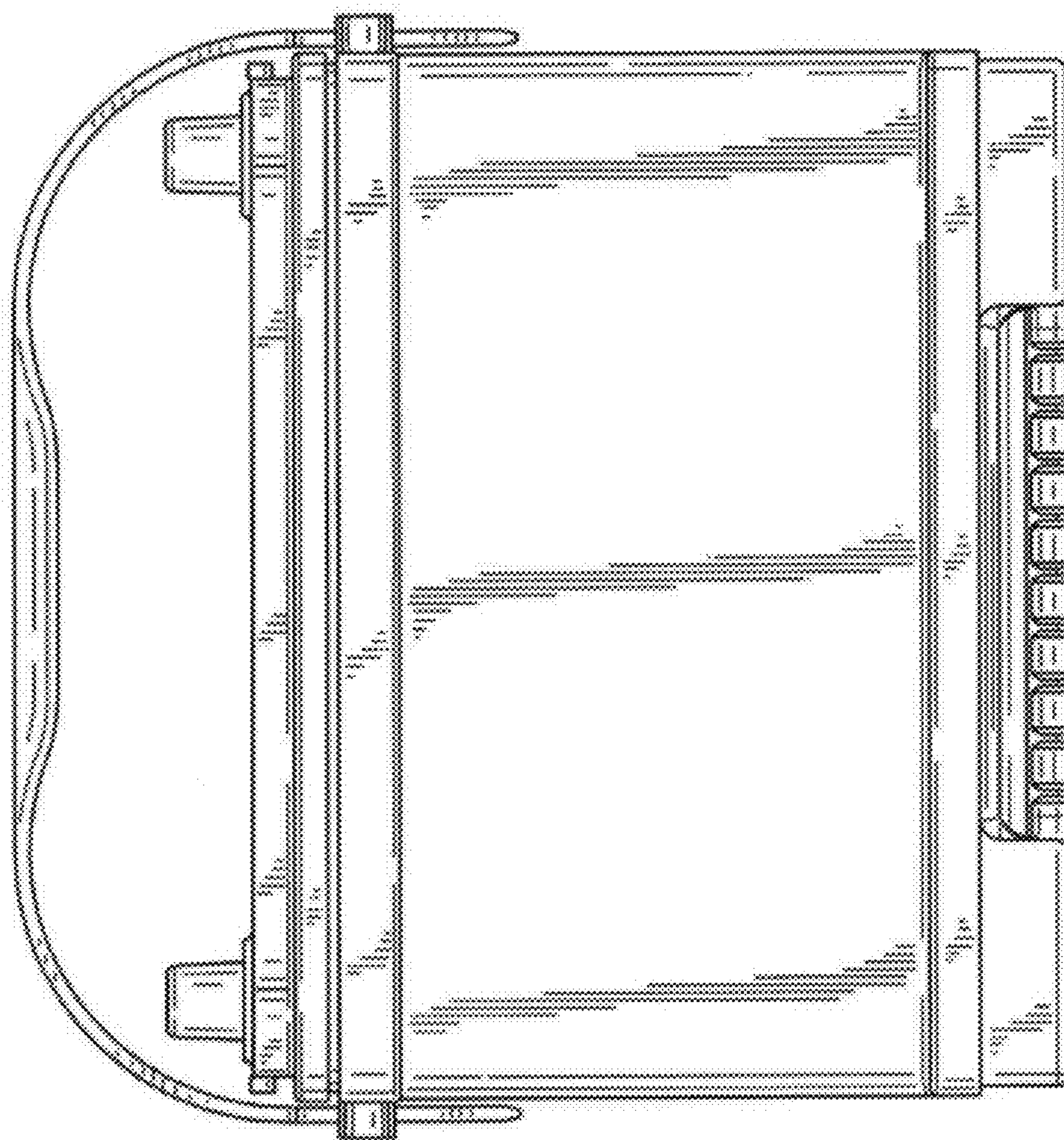

FIG. 2

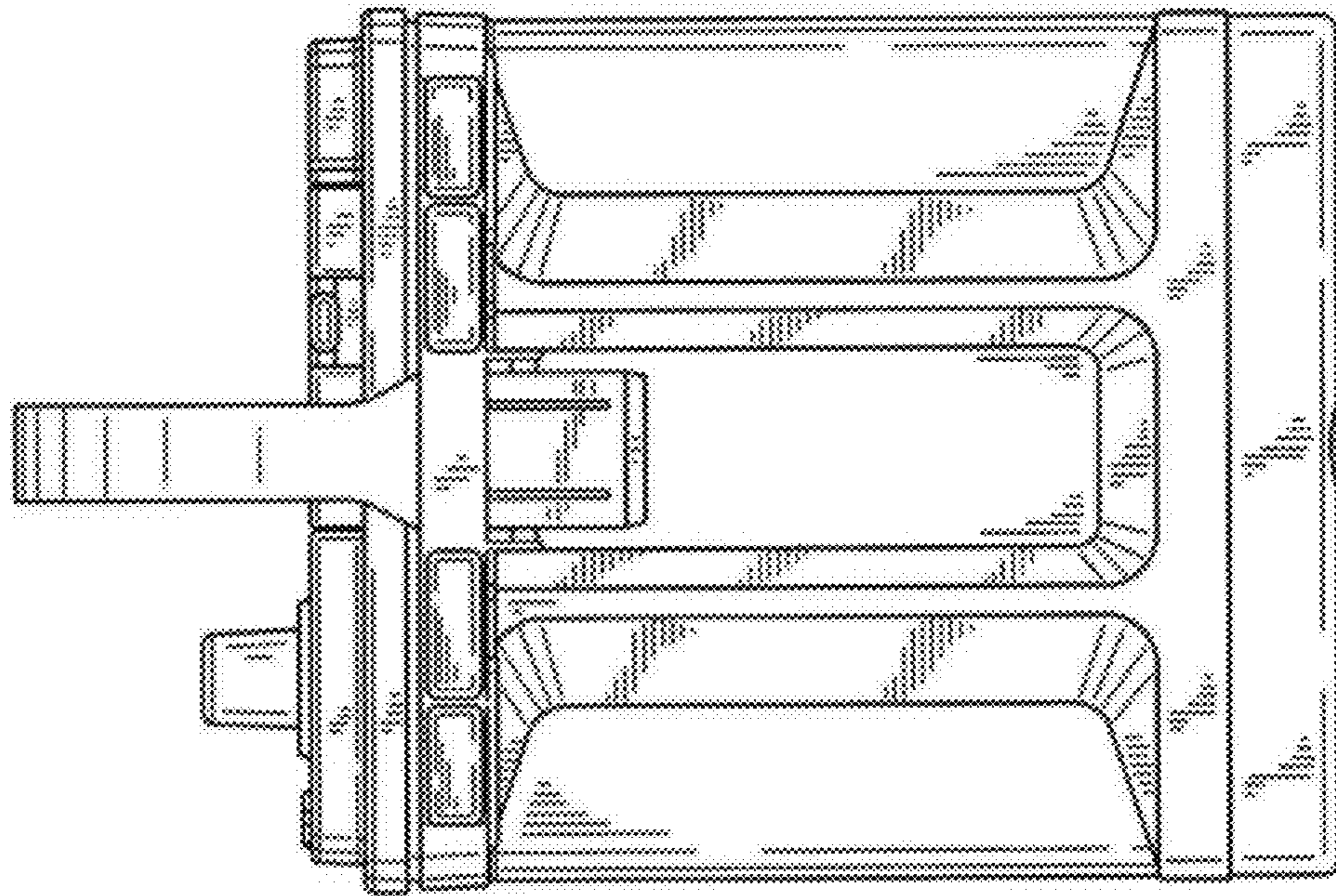

FIG. 3

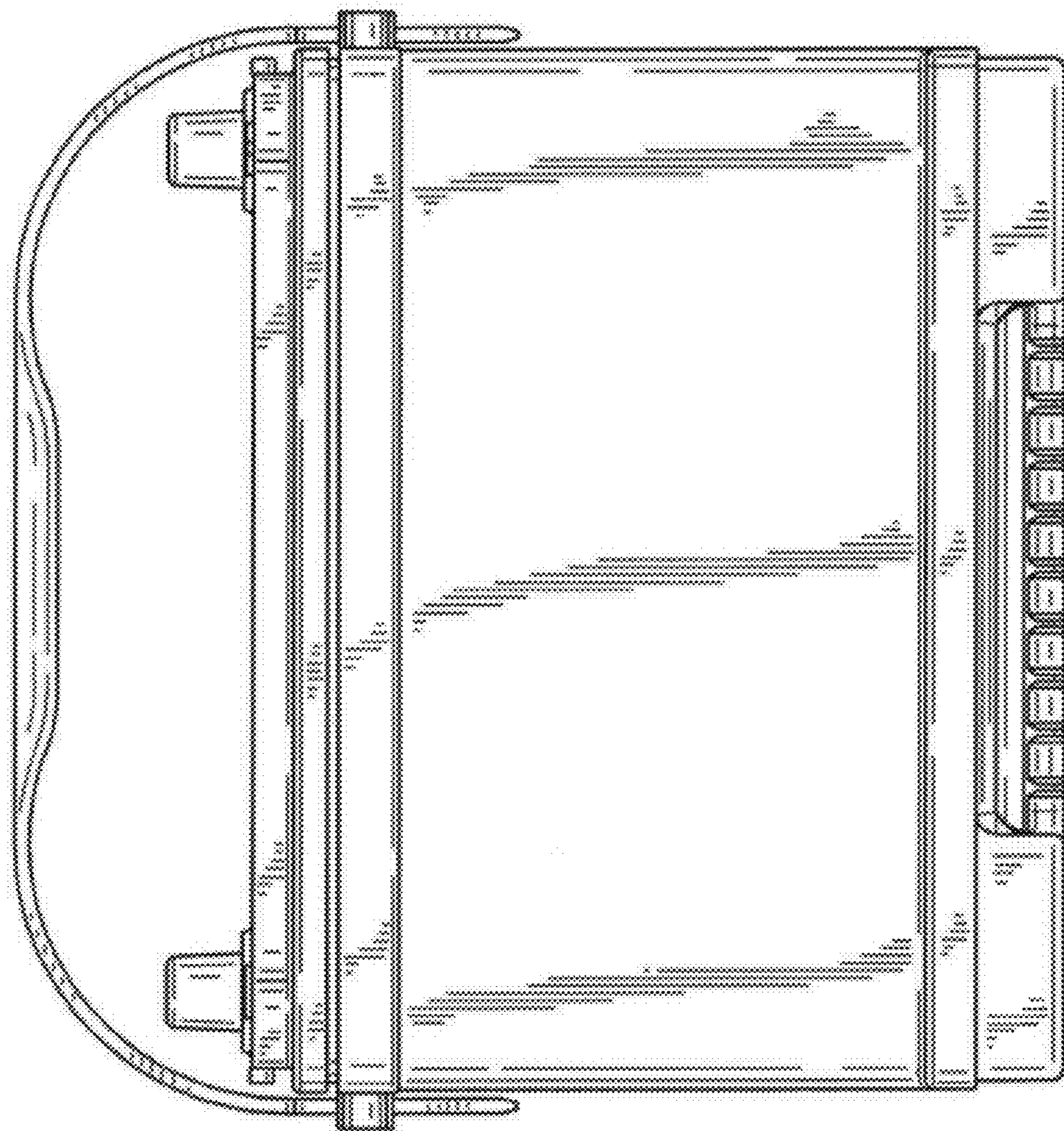

FIG. 4

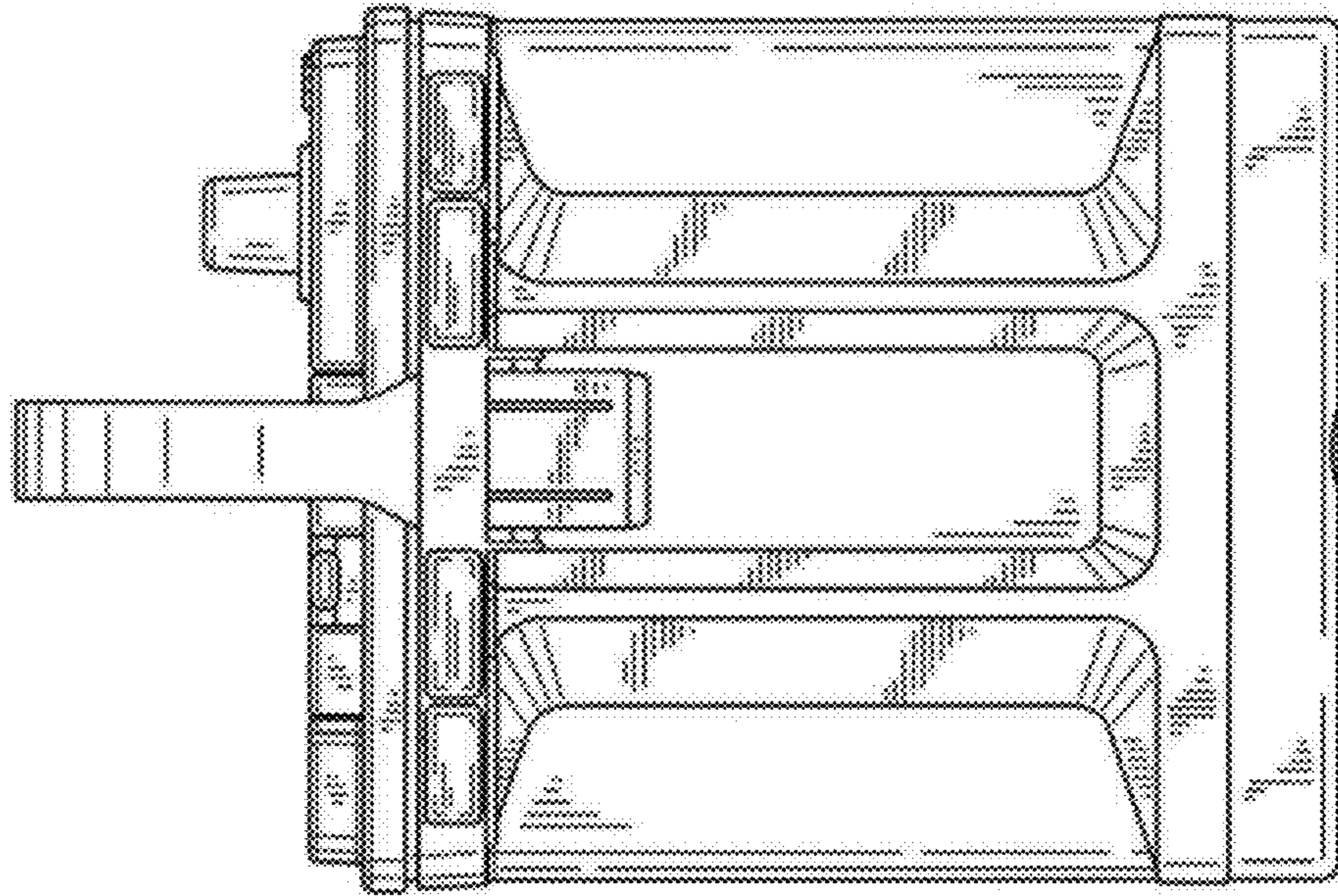

FIG. 5

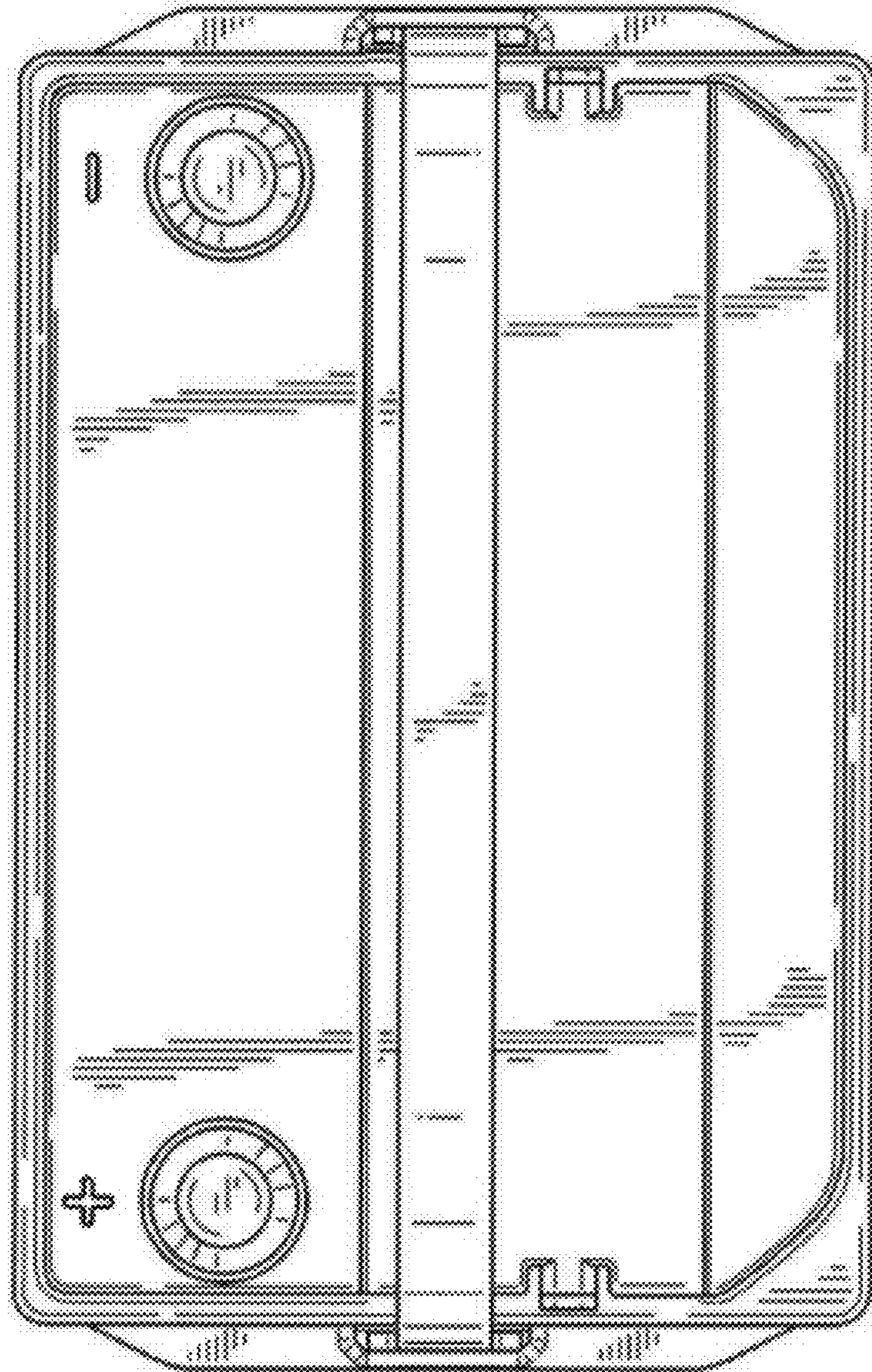

FIG. 6

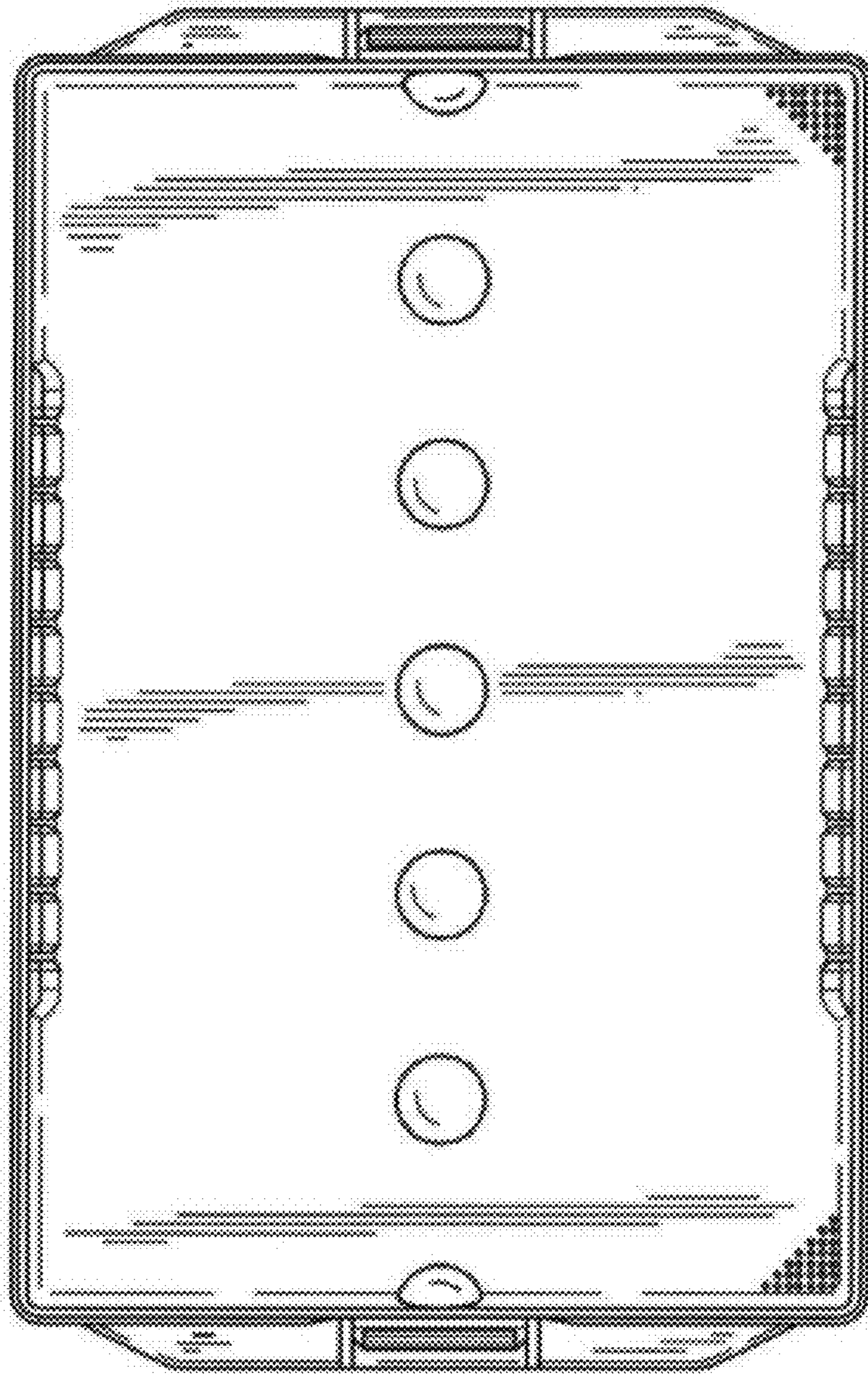

FIG. 7