



US00D660746S

(12) **United States Design Patent**  
**Bracy**

(10) **Patent No.:** **US D660,746 S**

(45) **Date of Patent:** **\*\* May 29, 2012**

(54) **ALL TERRAIN VEHICLE**

(75) Inventor: **Garth H Bracy**, Long Lake, MN (US)

(73) Assignee: **Polaris Industries Inc.**, Medina, MN (US)

(\*\*) Term: **14 Years**

(21) Appl. No.: **29/363,459**

(22) Filed: **Jun. 9, 2010**

(51) **LOC (9) Cl.** ..... **12-08**

(52) **U.S. Cl.** ..... **D12/87**

(58) **Field of Classification Search** ..... D12/86,  
D12/87, 1; D21/424, 433; 296/181.1, 181.5  
See application file for complete search history.

(56) **References Cited**

**U.S. PATENT DOCUMENTS**

5,036,939	A	8/1991	Johnson	
D441,690	S *	5/2001	Carr et al.	D12/87
D467,200	S *	12/2002	Luo et al.	D12/87
RE38,012	E	3/2003	Ochab	
D497,324	S *	10/2004	Chestnut et al.	D12/87
D503,658	S *	4/2005	Lu	D12/87
7,055,454	B1	6/2006	Whiting	
D535,215	S *	1/2007	Turner et al.	D12/87
D549,133	S *	8/2007	LePage	D12/87
D555,036	S *	11/2007	Eck	D12/87
D563,274	S *	3/2008	Ramos	D12/87
D606,900	S *	12/2009	Flores	D12/87
7,788,212	B2	6/2010	Fujishima	
D622,631	S *	8/2010	Lai et al.	D12/87
D625,662	S *	10/2010	Li	D12/87
7,819,220	B2	10/2010	Sunsdahl	
D641,288	S *	7/2011	Sun	D12/87

2008/0284124	A1	11/2008	Brady
2010/0090797	A1	4/2010	Koenig
2010/0317484	A1	12/2010	Gillingham
2010/0317485	A1	12/2010	Gillingham

**OTHER PUBLICATIONS**

Polaris 2010, ATVs and SidexSides Product Catalog, © 2009 Polaris Industries Inc., Medina, Minnesota; 52 pages.

Polaris Ranger 2009 Product Catalog, © 2008 Polaris Industries Inc., Medina, Minnesota; 32 pages.

Polaris 2008 Work/Play Only Ranger Product Catalog, © 2007 Polaris Industries Inc., Medina, Minnesota; 28 pages.

Polaris Ranger RZR Sharp SidexSide Performance 2008 Product Catalog, © 2007 Polaris Industries Inc., Medina, Minnesota; 12 pages.

\* cited by examiner

*Primary Examiner* — Melody N Brown

(74) *Attorney, Agent, or Firm* — Faegre Baker Daniels LLP

(57) **CLAIM**

I claim the ornamental design for the all terrain vehicle, as shown and described.

**DESCRIPTION**

FIG. 1 is a right, front perspective view of an all terrain vehicle showing my new design;

FIG. 2 is a right, rear perspective view thereof;

FIG. 3 is a right side elevation view thereof;

FIG. 4 is a left-hand side elevation view thereof;

FIG. 5 is a top plan view thereof; and,

FIG. 6 is a front elevation view thereof.

The broken lines shown are for the purpose of illustrating unclaimed portions of the vehicle.

**1 Claim, 6 Drawing Sheets**

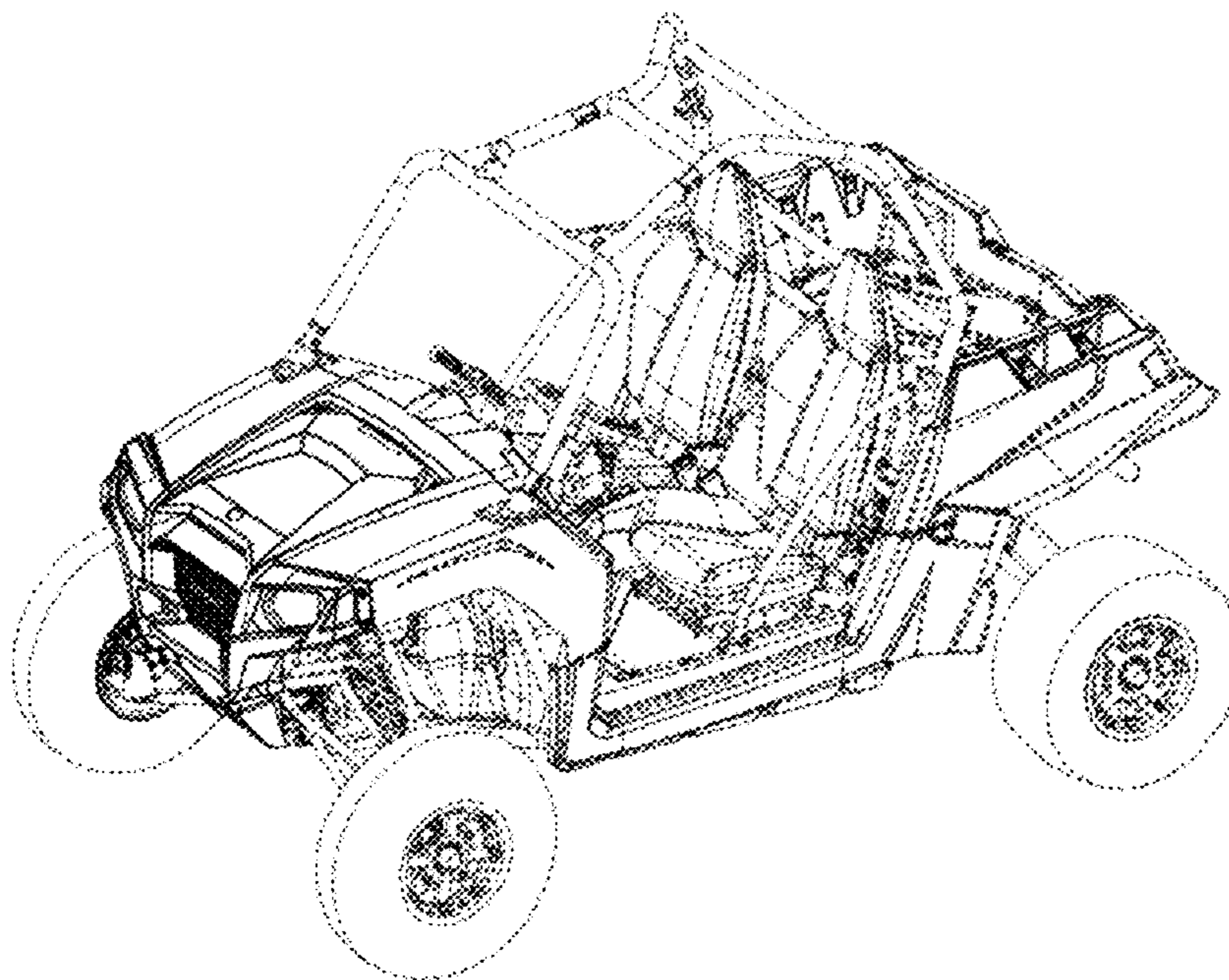

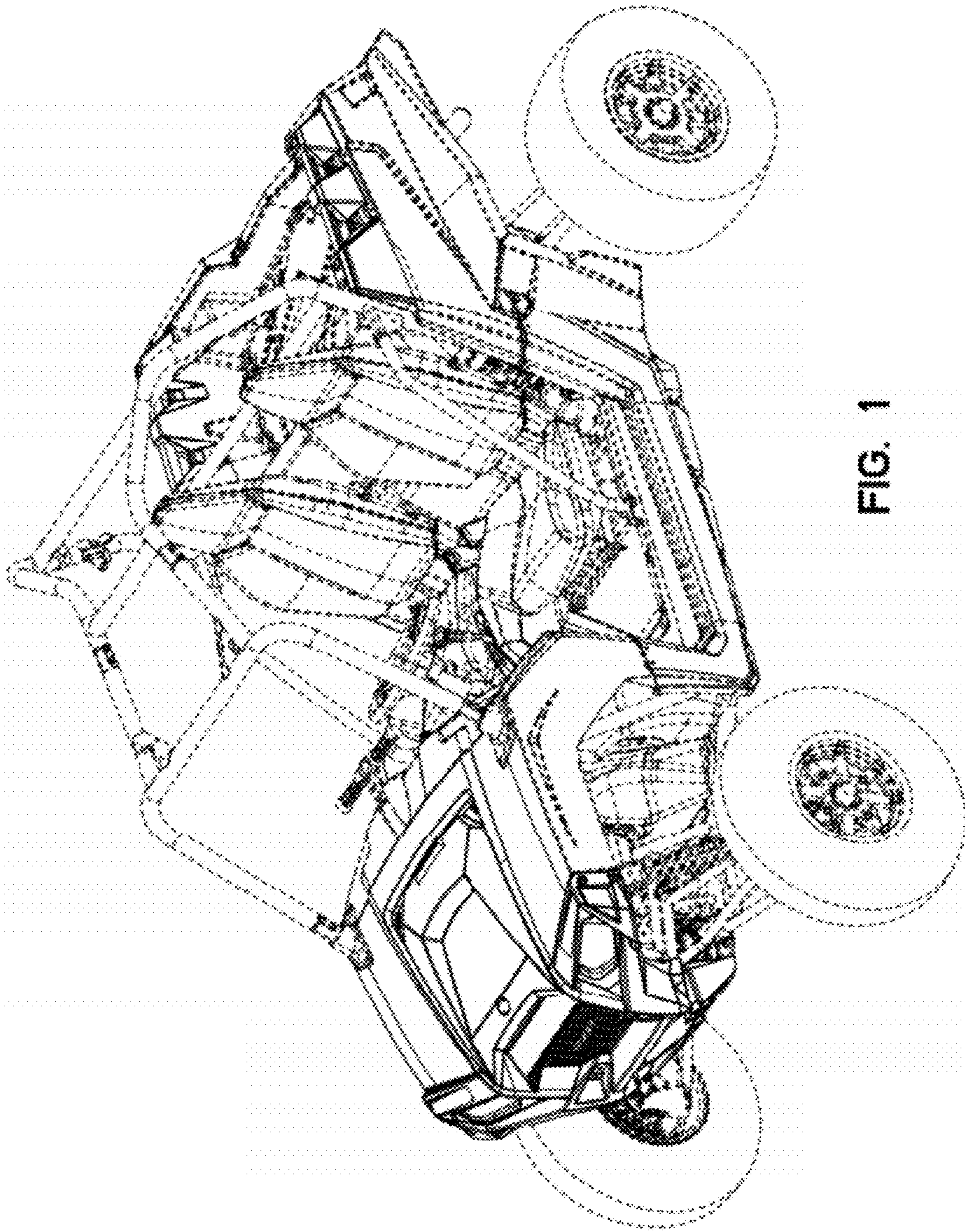

FIG. 1

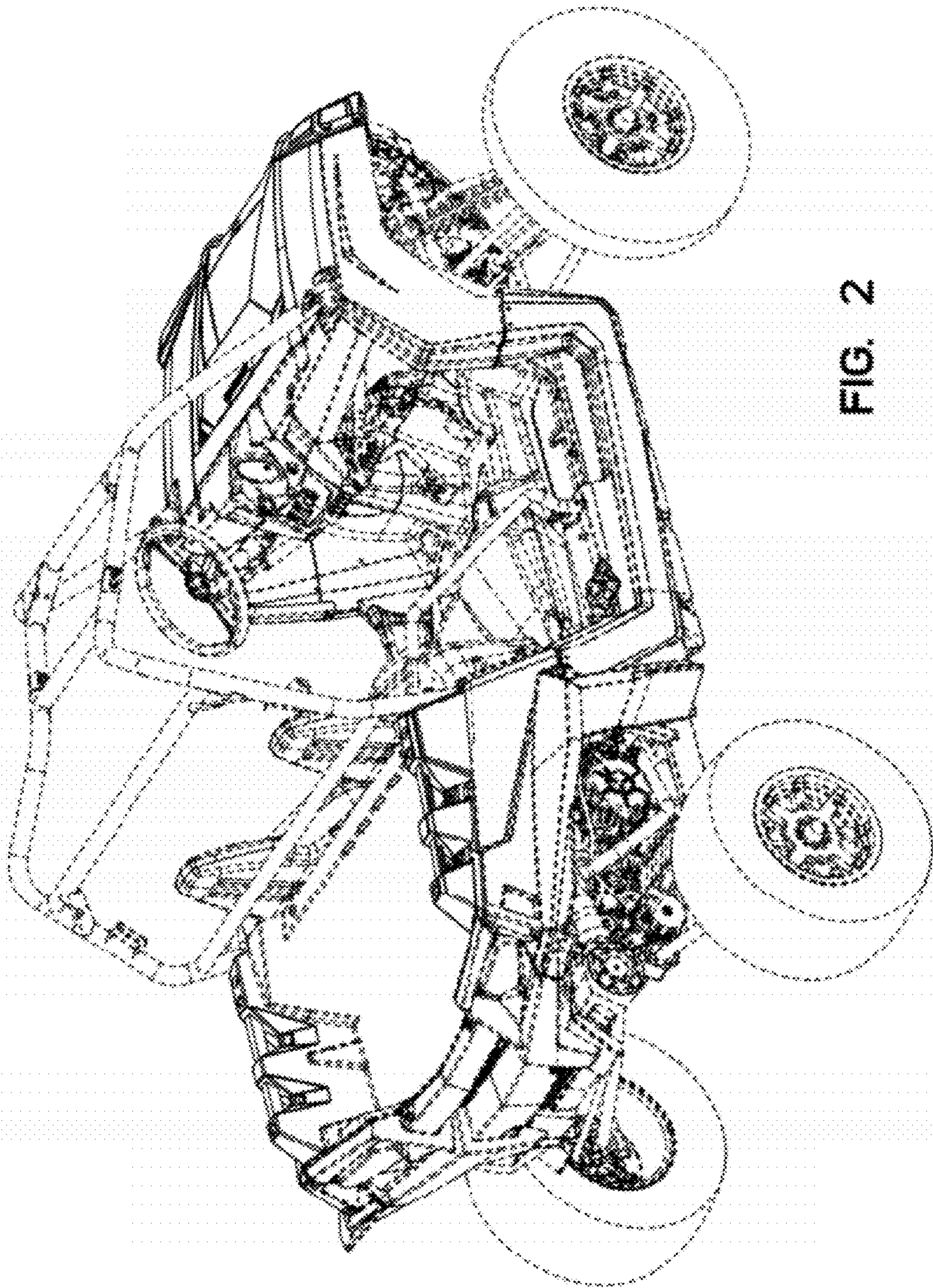

FIG. 2

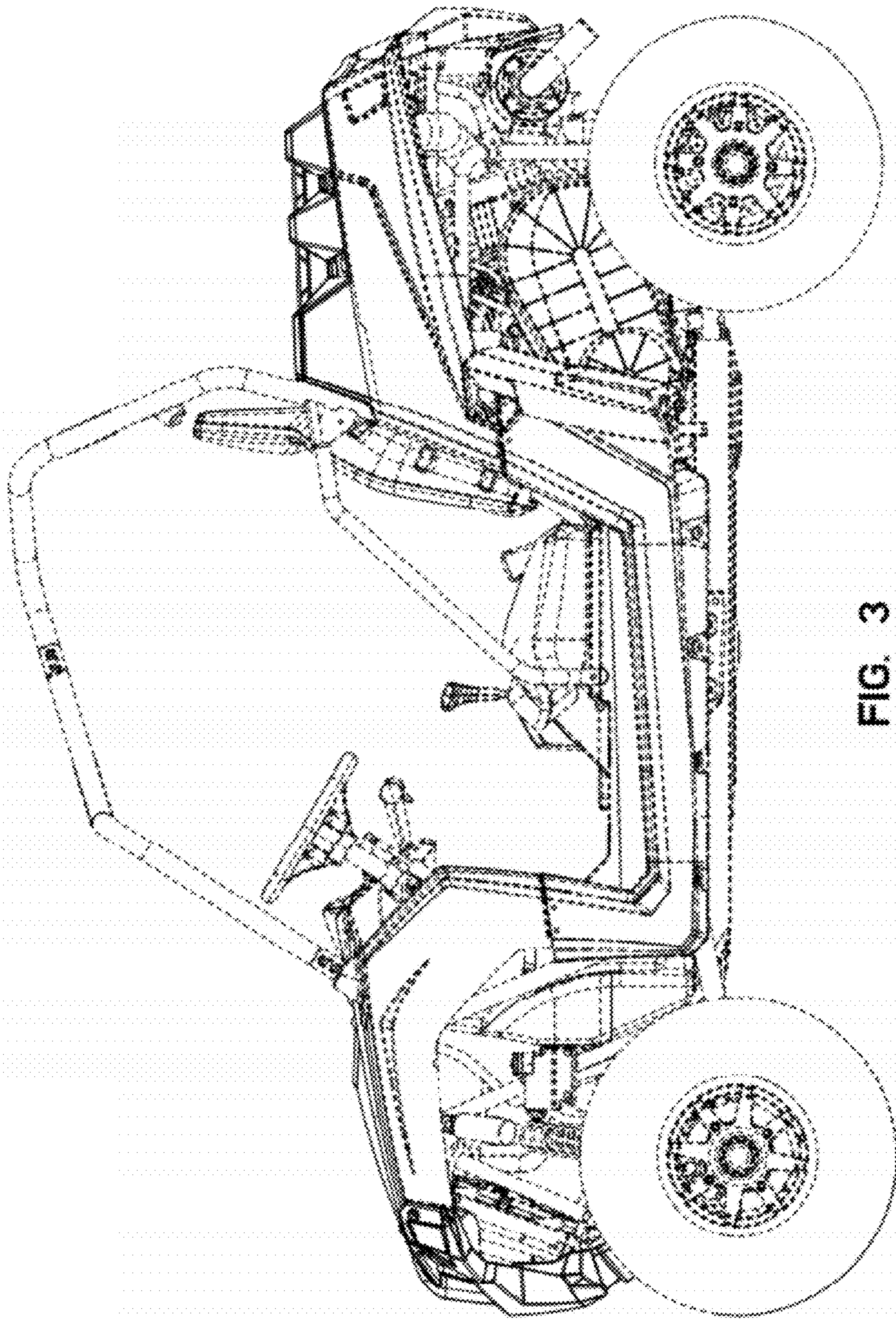

FIG. 3

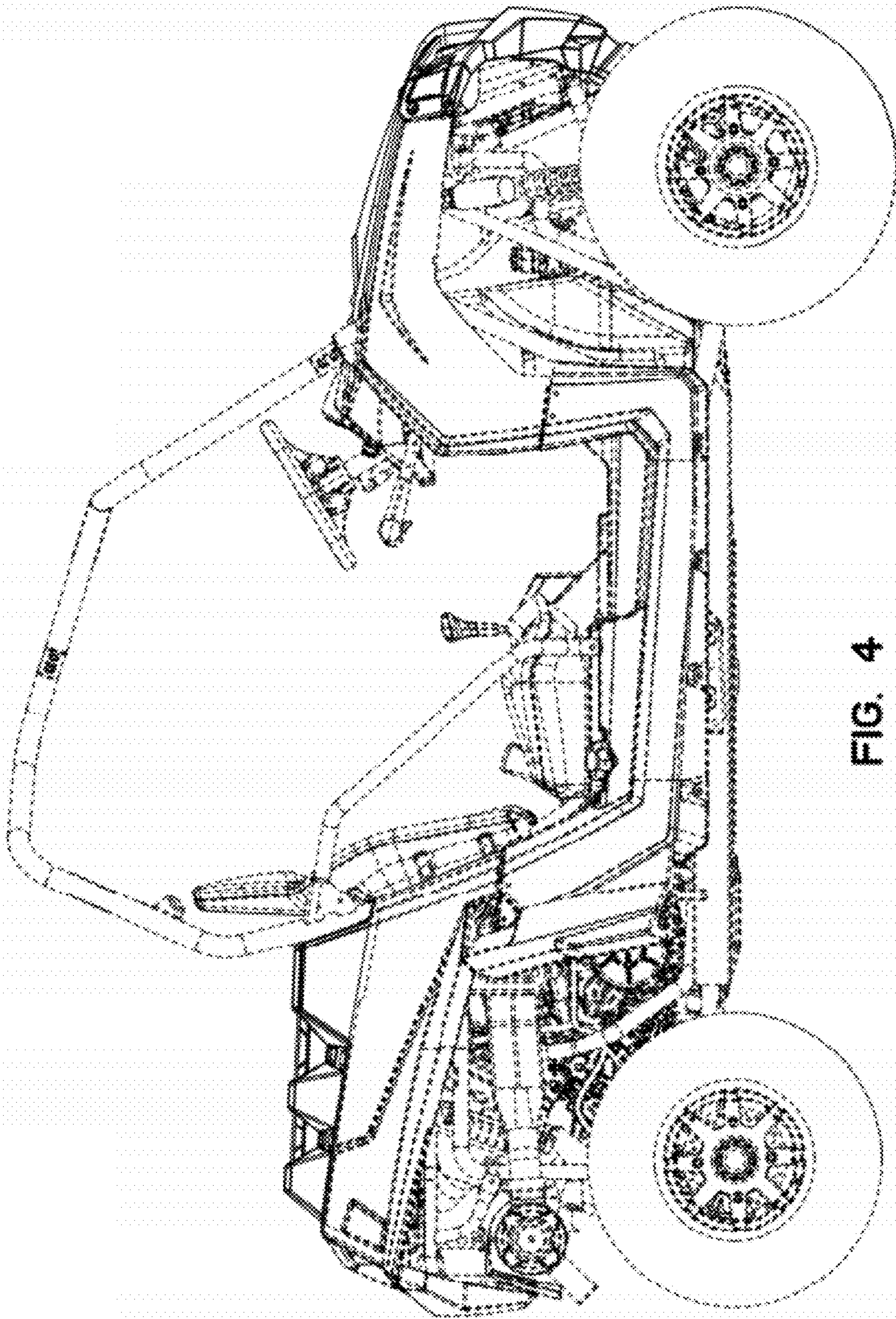

FIG. 4

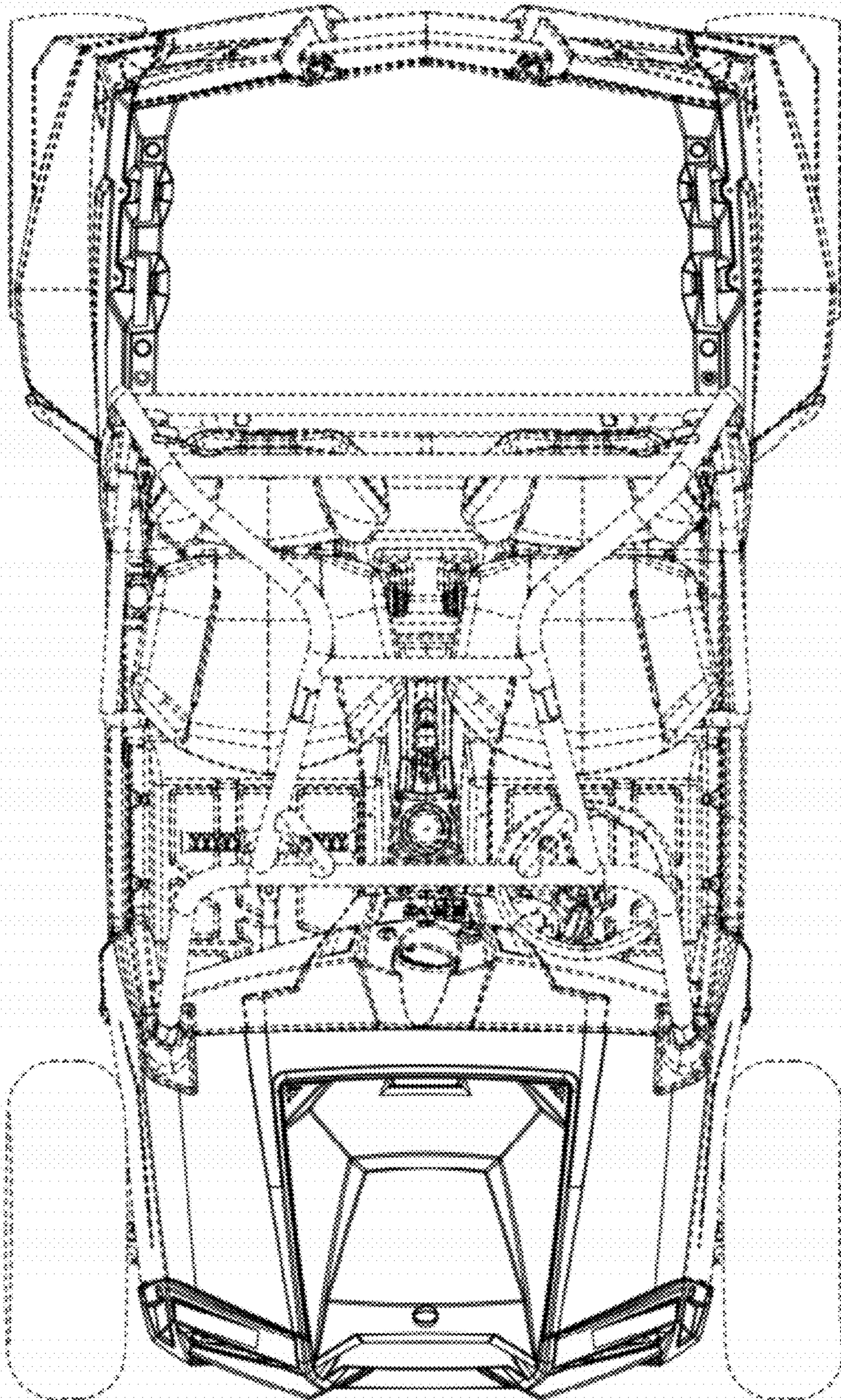

FIG. 5

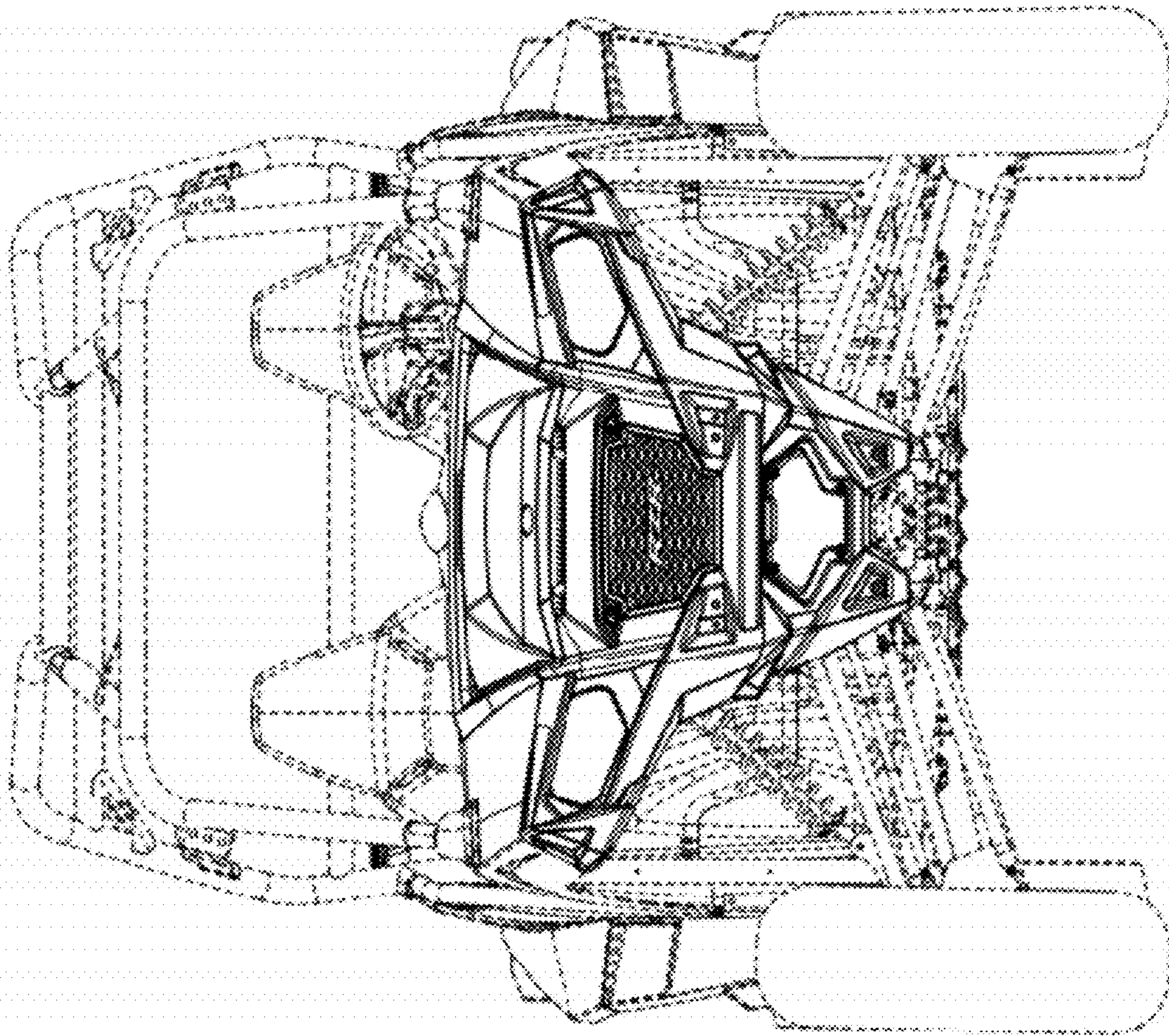

FIG. 6