



US00D660379S

(12) **United States Design Patent**
Glickman

(10) **Patent No.:** **US D660,379 S**

(45) **Date of Patent:** **** May 22, 2012**

(54) **TWO-LANE RACE TRACK SECTION FOR TOY VEHICLES**

(75) Inventor: **Joel I. Glickman**, Jupiter, FL (US)

(73) Assignee: **K'Nex Limited Partnership Group**, Hatfield, PA (US)

(**) Term: **14 Years**

(21) Appl. No.: **29/399,370**

(22) Filed: **Aug. 12, 2011**

(51) **LOC (9) Cl.** **21-01**

(52) **U.S. Cl.** **D21/565**

(58) **Field of Classification Search** D21/484,
D21/490, 493, 564, 565; 446/168-174, 84,
446/89, 108, 112, 114, 116, 124-128, 429,
446/444-447; 463/58-69; 238/10 R, 10 A-10 C,
238/10 E, 10 F; 104/60, 69

See application file for complete search history.

(56) **References Cited**

U.S. PATENT DOCUMENTS

3,589,064	A *	6/1971	Harada	446/445
3,734,404	A *	5/1973	Baynes et al.	238/10 E
6,093,079	A *	7/2000	House	446/444
6,227,932	B1 *	5/2001	Ngai	446/444
6,299,072	B1 *	10/2001	Burns	238/10 F

D459,007	S *	6/2002	Campacci	D25/119
6,601,774	B1 *	8/2003	Kasimoff	238/10 R
D573,665	S *	7/2008	Horikoshi	D21/565
D632,348	S *	2/2011	McNutt	D21/565
D640,331	S *	6/2011	Beauregard et al.	D21/565
2011/0250822	A1 *	10/2011	Koehl	446/444

* cited by examiner

Primary Examiner — Cynthia M Chin

(74) *Attorney, Agent, or Firm* — St. Onge Steward Johnston & Reens LLC

(57) **CLAIM**

The ornamental design for a two-lane race track section for toy vehicles, as shown and described.

DESCRIPTION

FIG. 1 is a front isometric view of a two-lane race track section for toy vehicles in accordance with the new design; FIG. 2 is a top plan view thereof; FIG. 3 is a side elevational view thereof, the opposite side being identical; FIG. 4 is a bottom plan view thereof; and, FIG. 5 is an end elevational view thereof, the opposite end being a mirror image thereof. The broken lines in FIGS. 1, 2 and 4 are intended to show environmental structure and form no part of the claimed design.

1 Claim, 4 Drawing Sheets

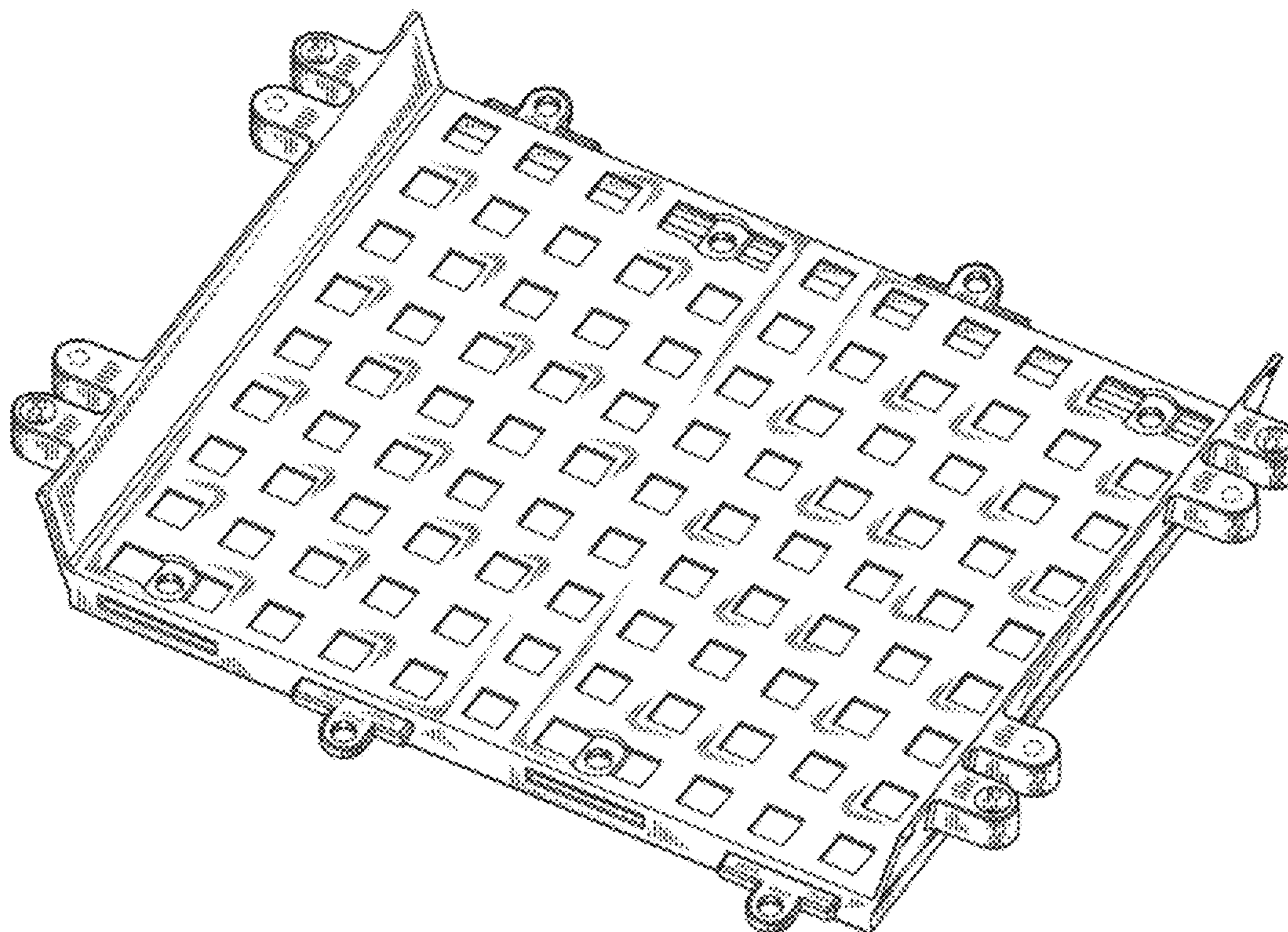

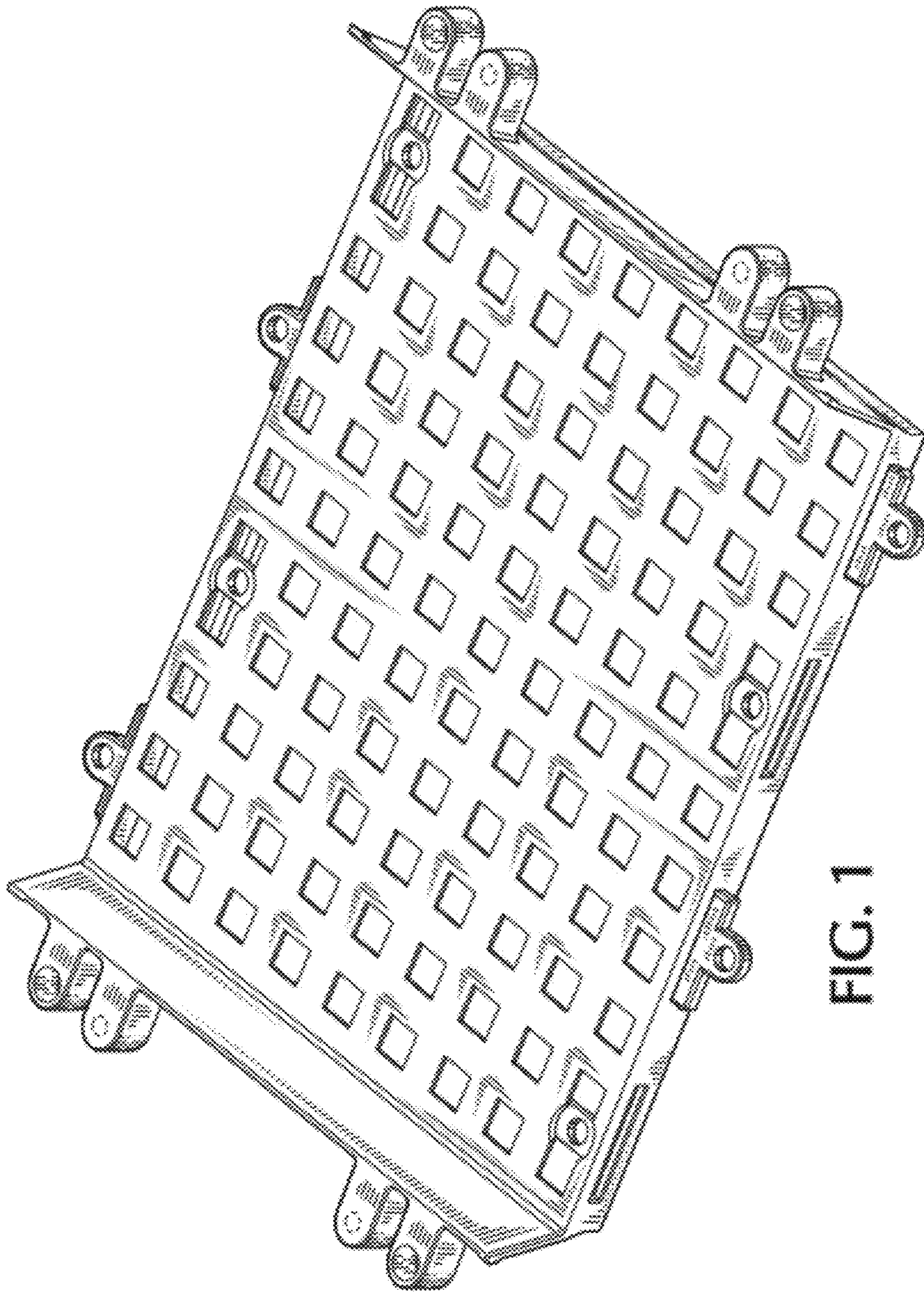

FIG. 1

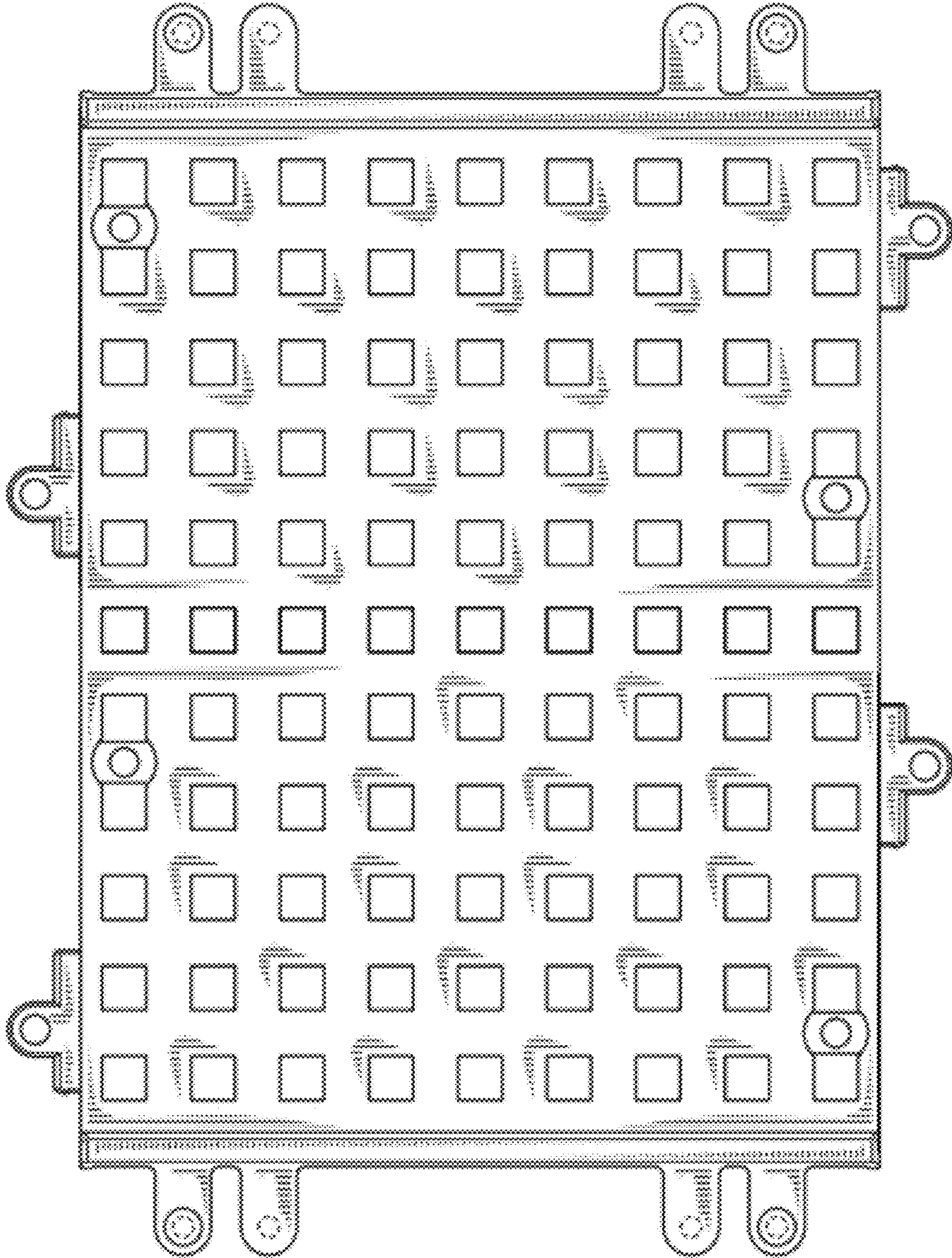

FIG. 2



FIG. 3

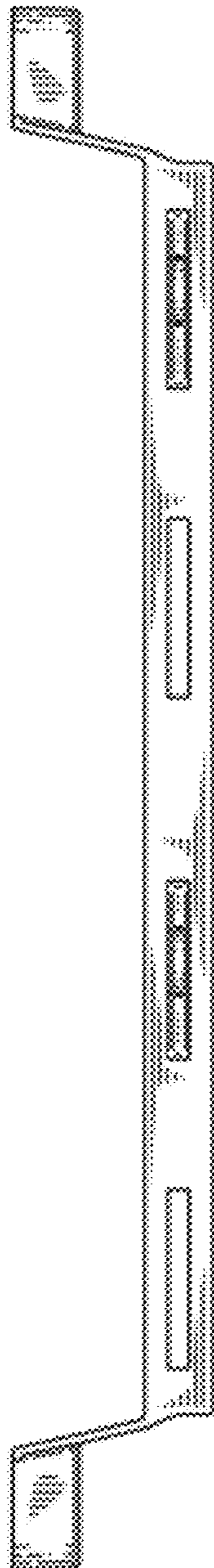

FIG. 5

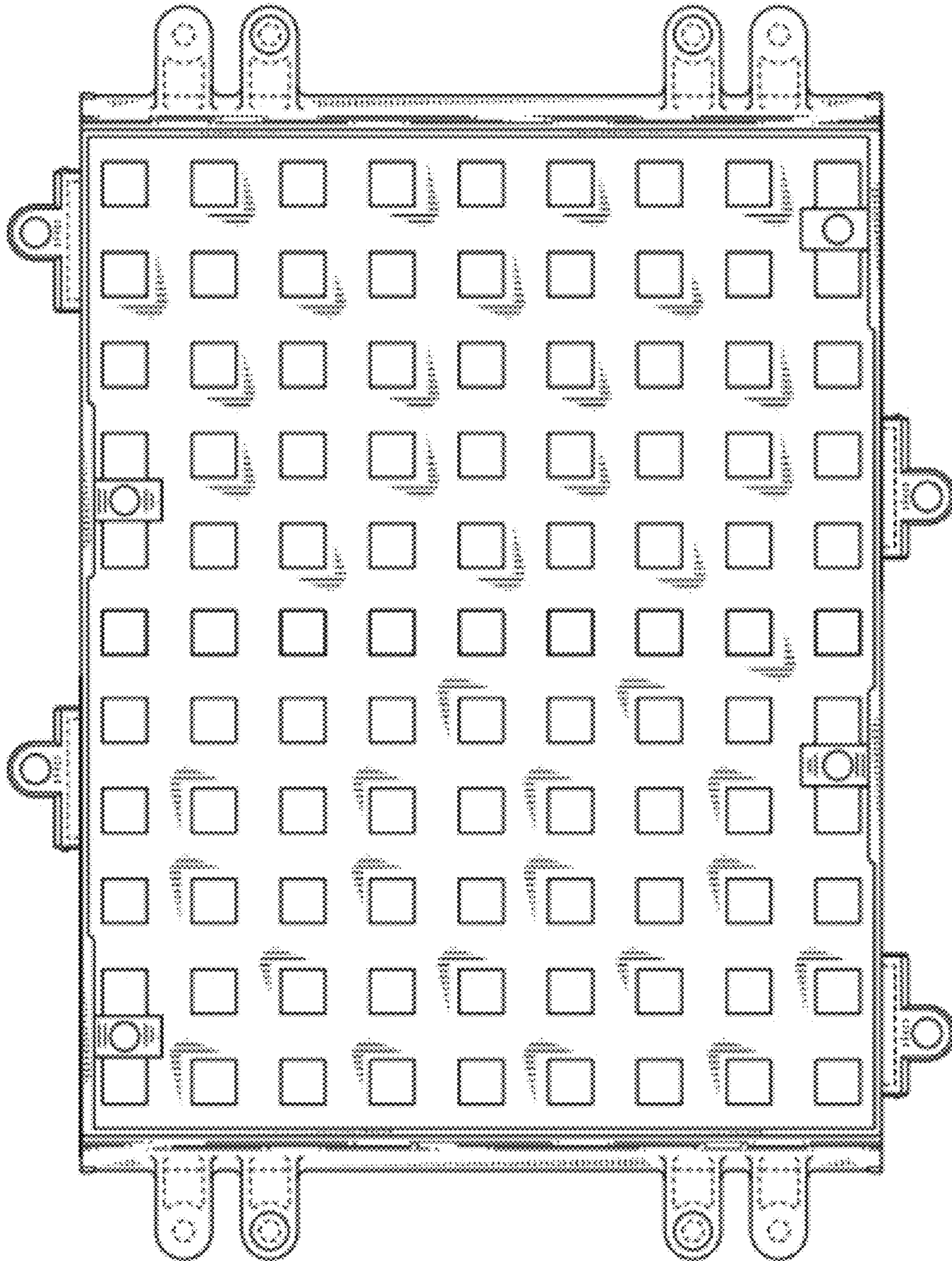

FIG. 4