



US00D660226S

(12) **United States Design Patent**  
**Elison et al.**

(10) **Patent No.:** **US D660,226 S**  
(45) **Date of Patent:** **\*\* May 22, 2012**

- (54) **BATTERY**
  - (75) Inventors: **Nicholas E. Elison**, Milwaukee, WI (US); **Glenn W. Andersen**, Hartford, WI (US)
  - (73) Assignee: **Johnson Controls Technology Company**, Holland, MI (US)
  - (\*\*) Term: **14 Years**
  - (21) Appl. No.: **29/404,784**
  - (22) Filed: **Oct. 25, 2011**
  - (51) **LOC (9) Cl.** ..... **13-02**
  - (52) **U.S. Cl.** ..... **D13/104**
  - (58) **Field of Classification Search** ..... D13/102-106, D13/110, 118-119, 184; 429/96-100, 149, 429/163, 176, 187
- See application file for complete search history.

- D303,519 S 9/1989 Lopez-Doriga
  - D303,652 S 9/1989 Lopez-Doriga
  - D303,653 S 9/1989 Lopez-Doriga
  - D304,926 S 12/1989 Ching, Jr.
  - D304,927 S 12/1989 Ching, Jr.
  - 4,891,270 A 1/1990 Jergl et al.
  - D307,133 S 4/1990 Ching, Jr.
  - D307,886 S 5/1990 Ching, Jr. et al.
  - D310,205 S 8/1990 Hedrington et al.
  - D310,821 S 9/1990 Hulsebus et al.
  - D318,025 S 7/1991 Moritaka
  - D327,051 S 6/1992 Schwartz
  - 5,283,137 A \* 2/1994 Ching ..... 429/175
  - D344,676 S 3/1994 Newman
  - D356,993 S 4/1995 Koster
  - 5,415,956 A \* 5/1995 Ching ..... 429/187
  - 5,440,785 A \* 8/1995 McDonald ..... 16/423
  - 5,484,667 A \* 1/1996 Sahli et al. .... 429/100
  - D367,042 S 2/1996 Morrow
  - 5,492,779 A \* 2/1996 Ronning ..... 429/120
- (Continued)

(56) **References Cited**

**U.S. PATENT DOCUMENTS**

- D64,969 S 6/1924 Glidden
- D67,258 S 5/1925 Bello
- D68,262 S 9/1925 Klug
- D70,400 S 6/1926 Campbell
- D75,446 S 6/1928 Rieser
- 2,724,360 A 11/1955 Crookshank
- D181,079 S \* 9/1957 Slautterback ..... D13/104
- 2,902,532 A \* 9/1959 Toce et al. .... 429/99
- D188,421 S 7/1960 Slautterback
- 3,105,909 A 10/1963 Jones
- D197,519 S 2/1964 Rohe
- D211,348 S 6/1968 Redmon
- D239,837 S 5/1976 Hennen
- 3,963,972 A 6/1976 Todd
- D252,354 S 7/1979 Uyeda
- 4,346,151 A 8/1982 Uba et al.
- D266,757 S 11/1982 Campbell et al.
- 4,510,215 A 4/1985 Adam
- 4,693,949 A \* 9/1987 Kellett et al. .... 429/128
- D292,576 S 11/1987 Kump et al.
- D298,029 S 10/1988 Foster
- D303,373 S 9/1989 Ching, Jr.

**OTHER PUBLICATIONS**

Photographs of "old" Optima battery with a date stamp of Week 47, 1990.

(Continued)

*Primary Examiner* — Rosemary K Tarcza

(74) *Attorney, Agent, or Firm* — Boardman & Clark LLP

(57) **CLAIM**

The ornamental design for a battery, as shown and described.

**DESCRIPTION**

FIG. 1 is a top isometric view of the battery according to an exemplary embodiment;  
FIG. 2 is a first side elevation view thereof;  
FIG. 3 is a first end elevation view thereof;  
FIG. 4 is a second side elevation view thereof;  
FIG. 5 is a second end elevation view thereof;  
FIG. 6 is a top plan view thereof; and,  
FIG. 7 is a bottom plan view thereof.

**1 Claim, 7 Drawing Sheets**

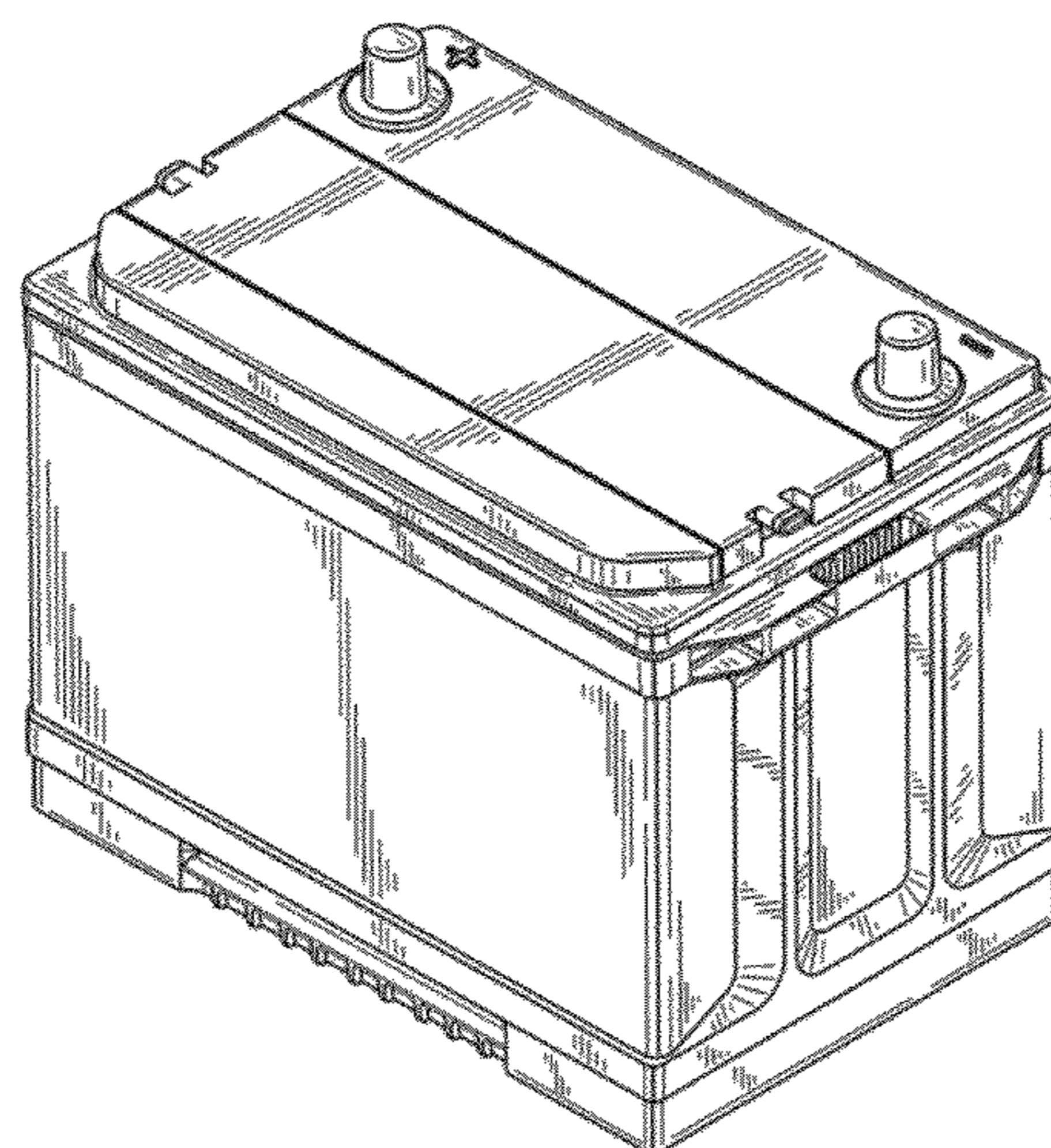

# US D660,226 S

Page 2

## U.S. PATENT DOCUMENTS

D372,701	S	8/1996	Tahmassebpur			
5,599,641	A	2/1997	Ching, Jr. et al.			
5,663,008	A *	9/1997	Shimakawa et al. ....	429/443		
5,686,202	A	11/1997	Hooke et al.			
5,763,116	A	6/1998	Lapinski et al.			
D400,849	S *	11/1998	Ikeda et al. ....	D13/106		
D401,551	S *	11/1998	Kim .....	D13/106		
5,856,037	A	1/1999	Casale et al.			
5,871,862	A	2/1999	Olson			
D406,258	S	3/1999	Segers			
5,895,728	A	4/1999	Walker et al.			
5,977,746	A	11/1999	Hershberger et al.			
5,998,062	A	12/1999	Olson			
6,022,638	A	2/2000	Horton et al.			
6,023,146	A	2/2000	Casale et al.			
6,025,086	A	2/2000	Ching			
6,153,331	A	11/2000	Brantley et al.			
6,174,618	B1	1/2001	Nishiyama et al.			
6,183,903	B1	2/2001	Campbell et al.			
D442,542	S	5/2001	Dougherty et al.			
6,303,247	B1	10/2001	Griffey et al.			
D450,653	S	11/2001	Hertel et al.			
D458,900	S *	6/2002	Carter et al. ....	D13/106		
6,399,238	B1	6/2002	Oweis et al.			
D462,656	S *	9/2002	Degen et al. ....	D13/104		
D466,478	S	12/2002	Bolstad et al.			
D491,138	S	6/2004	Minato			
D495,994	S	9/2004	Arakelian			
D499,070	S	11/2004	Lavington			
6,929,882	B1	8/2005	Carter			
D517,479	S	3/2006	Schemm			
D517,987	S	3/2006	Castagnola et al.			
D517,988	S	3/2006	Ihde et al.			
D527,344	S	8/2006	Rajpara et al.			
D553,565	S	10/2007	Kawakita et al.			
D562,229	S	2/2008	Peters			
7,332,243	B2	2/2008	Cummins et al.			
D600,202	S	9/2009	Mack			
D606,938	S	12/2009	Mack			
D606,939	S	12/2009	Mack			
D606,940	S	12/2009	Mack			
D607,405	S	1/2010	Mack			
D607,406	S	1/2010	Mack			
D607,407	S	1/2010	Mack			
D608,283	S	1/2010	Mack			
D609,178	S	2/2010	Mack			
D609,179	S	2/2010	Mack			
D609,631	S	2/2010	Mack			
D610,089	S	2/2010	Mack			
D614,126	S	4/2010	Chen			
D621,353	S	8/2010	Mack			
D625,253	S	10/2010	Mack			
D625,254	S	10/2010	Mack			
D633,866	S *	3/2011	Qualls et al. ....	D13/106		
D635,509	S	4/2011	Mack			
D647,051	S *	10/2011	Qualls et al. ....	D13/106		
D647,052	S *	10/2011	Qualls et al. ....	D13/106		
2003/0059676	A1	3/2003	Rodriguez et al.			
2004/0170888	A1	9/2004	Cummins et al.			
2005/0069762	A1	3/2005	Daley et al.			
2011/0293980	A1 *	12/2011	Tartaglia .....	429/100		

## OTHER PUBLICATIONS

Optima Batteries brochure entitled "The Ultimate Power Source" dated Mar. 2007.

Optima Batteries New Product Announcement, 2008.

\* cited by examiner

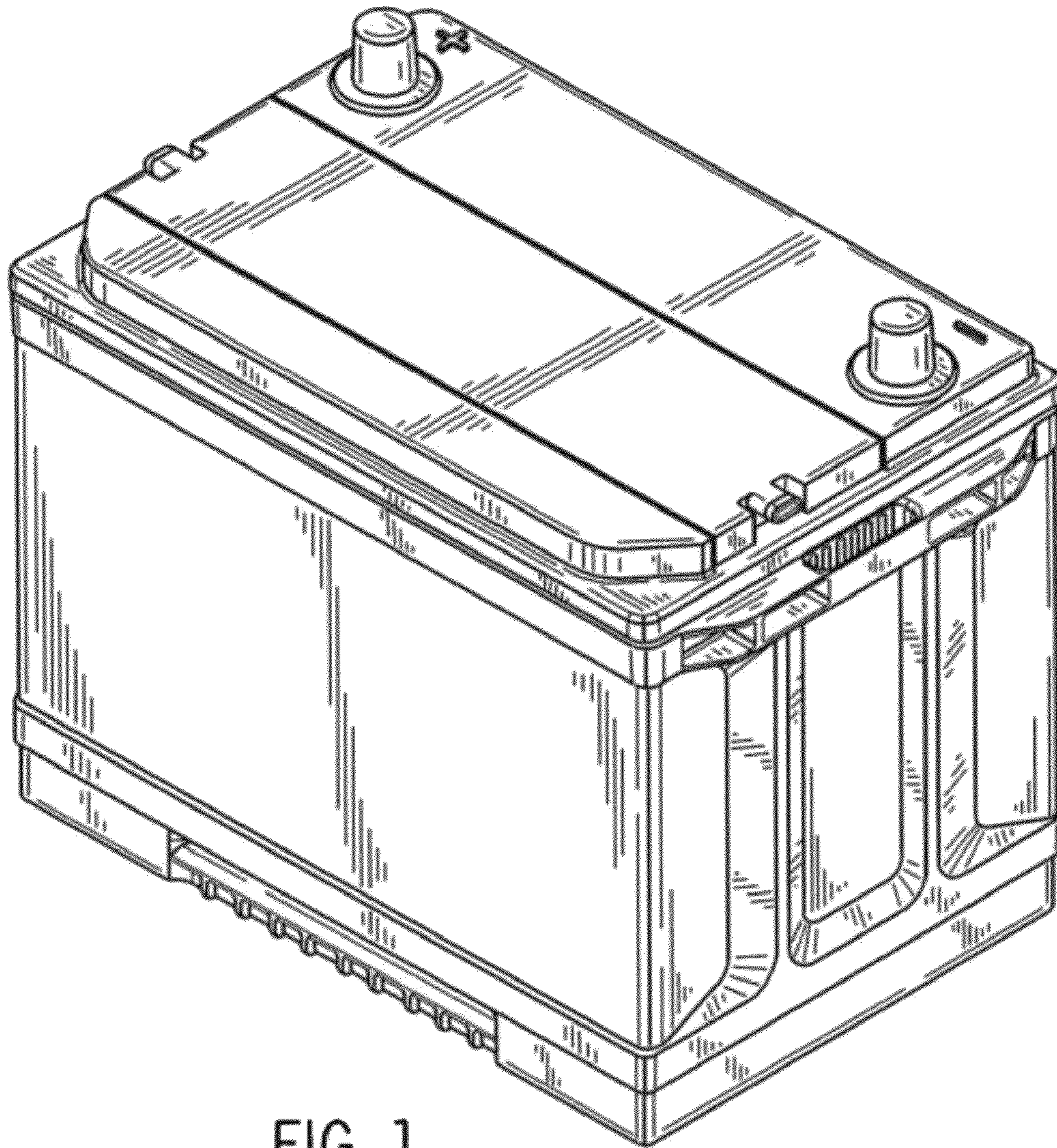

FIG. 1

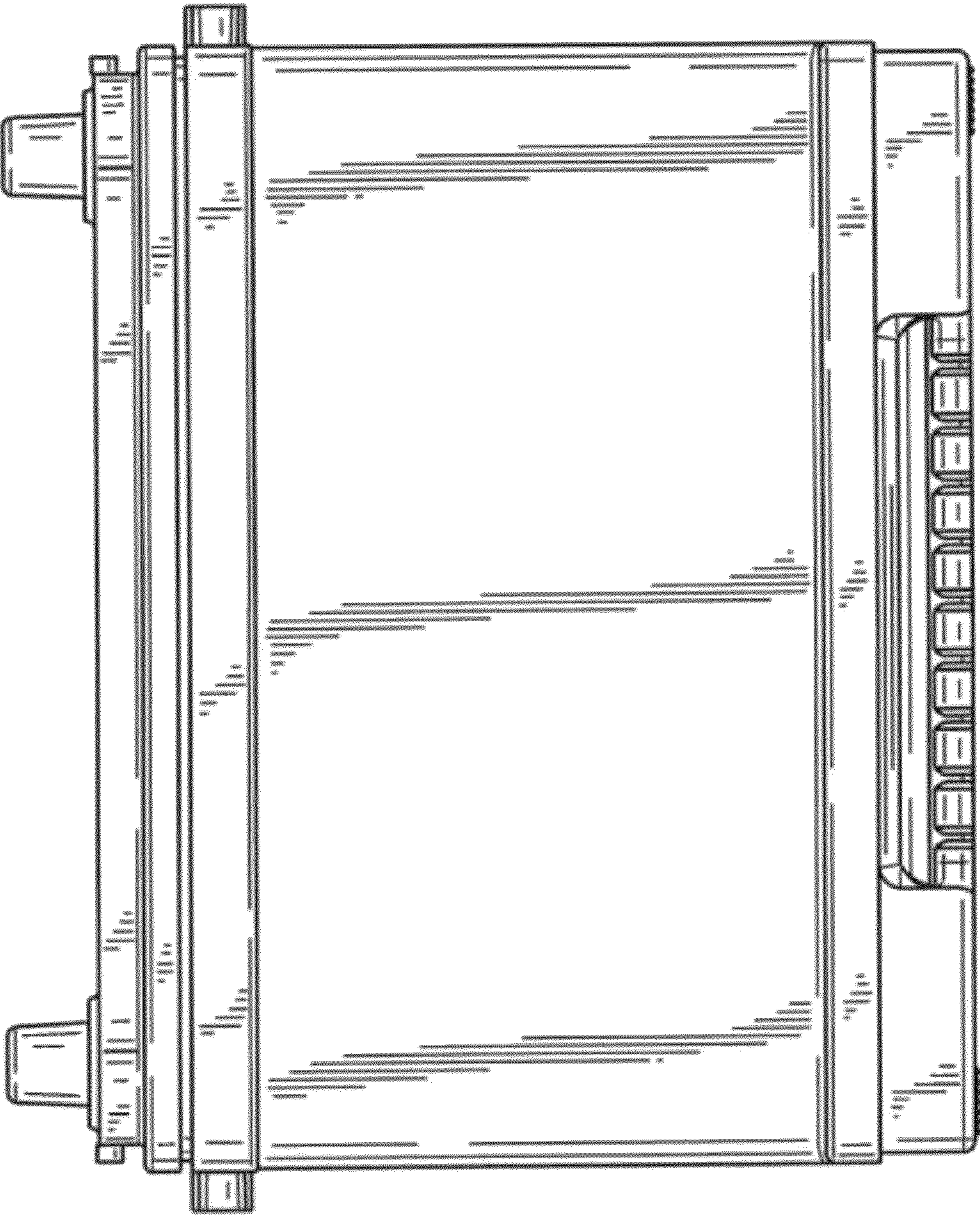

FIG. 2

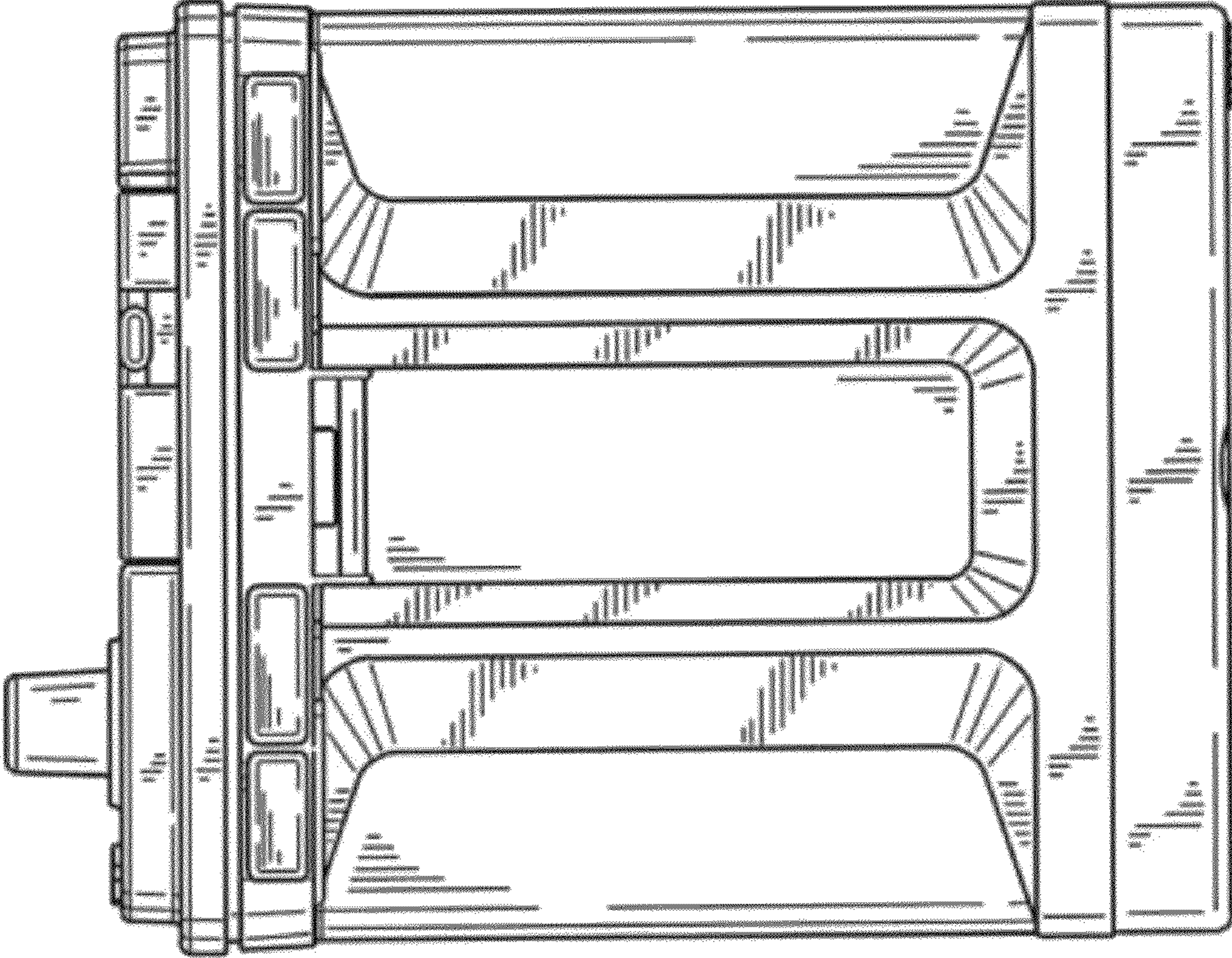

FIG. 3

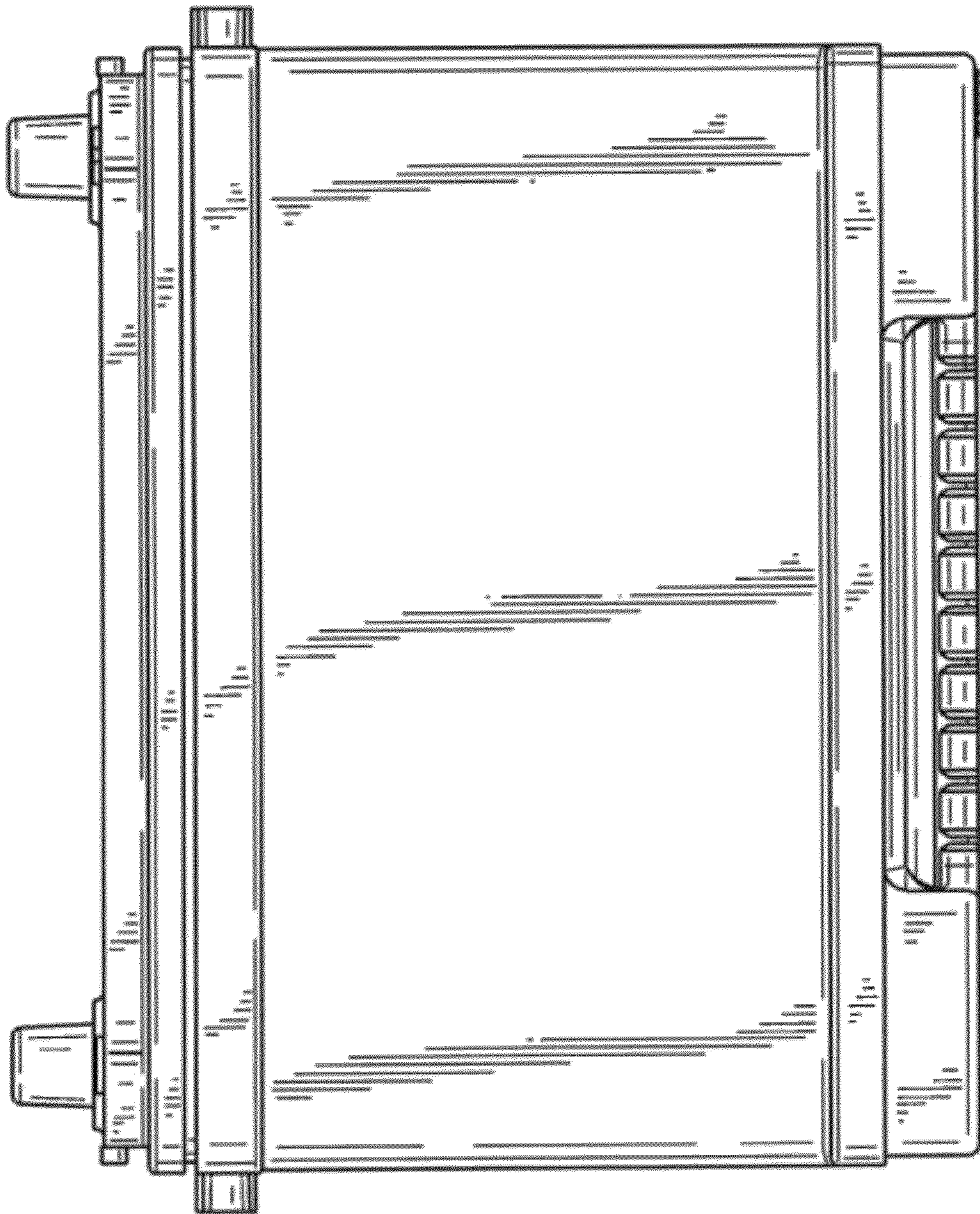

FIG. 4

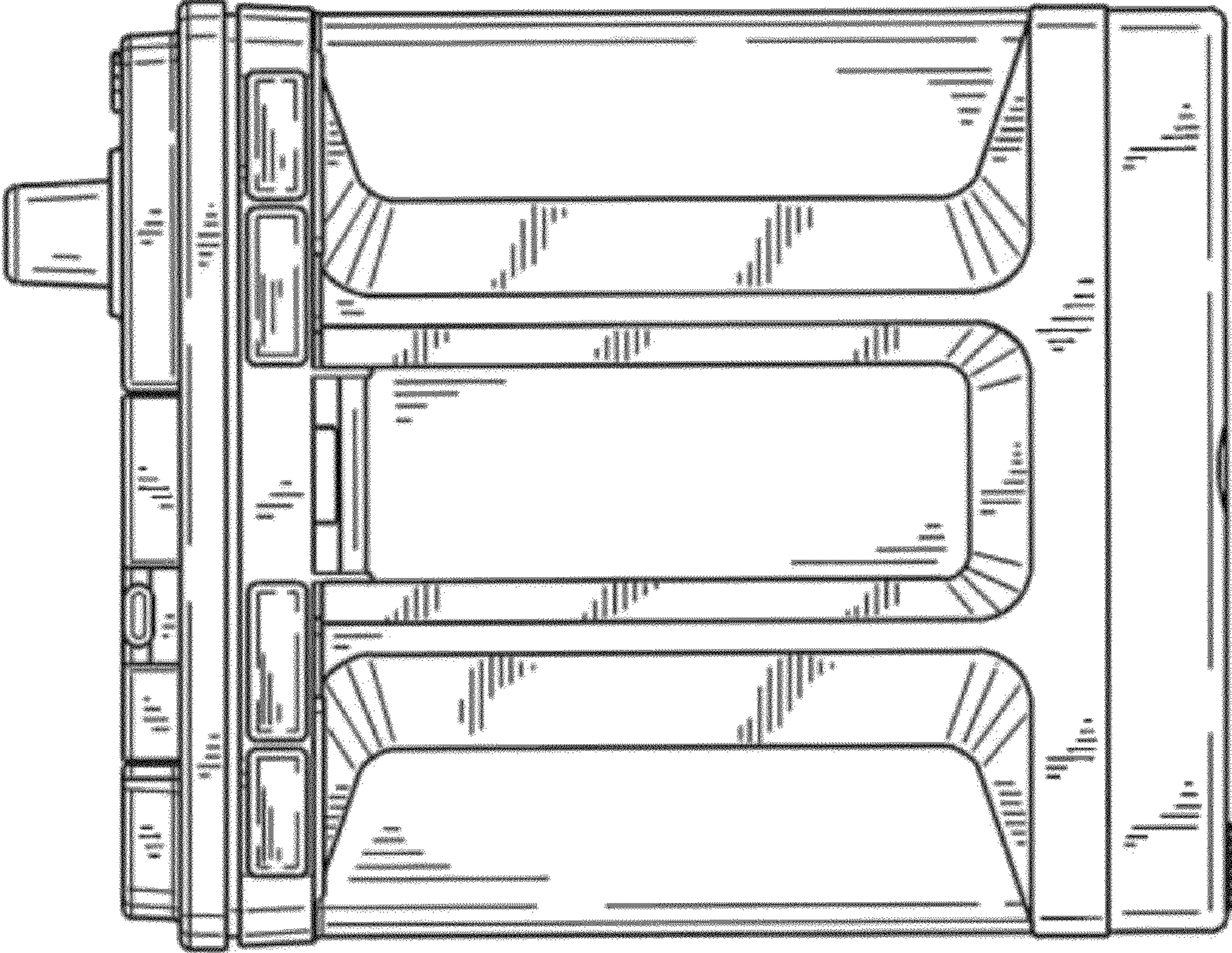

FIG. 5

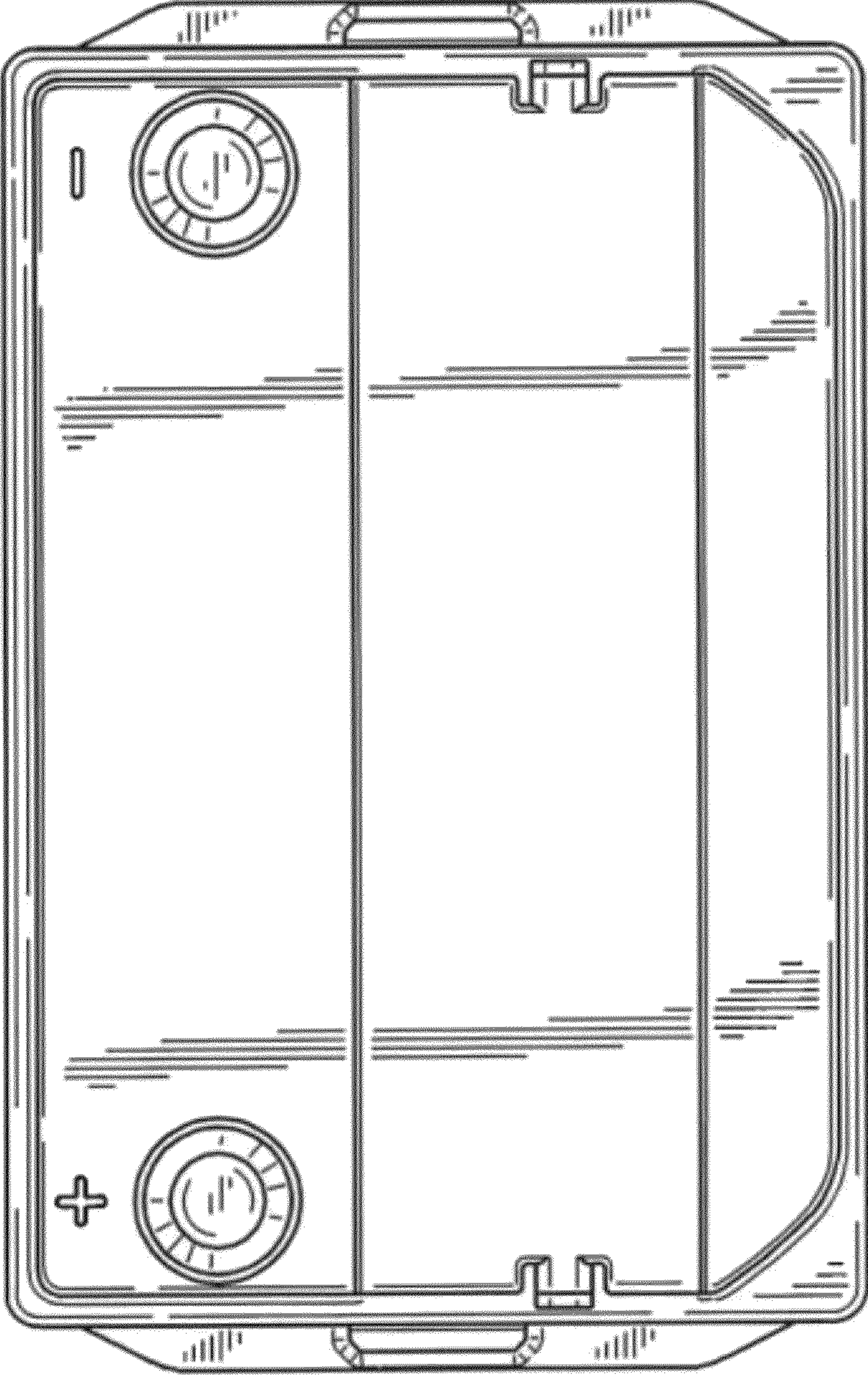

FIG. 6



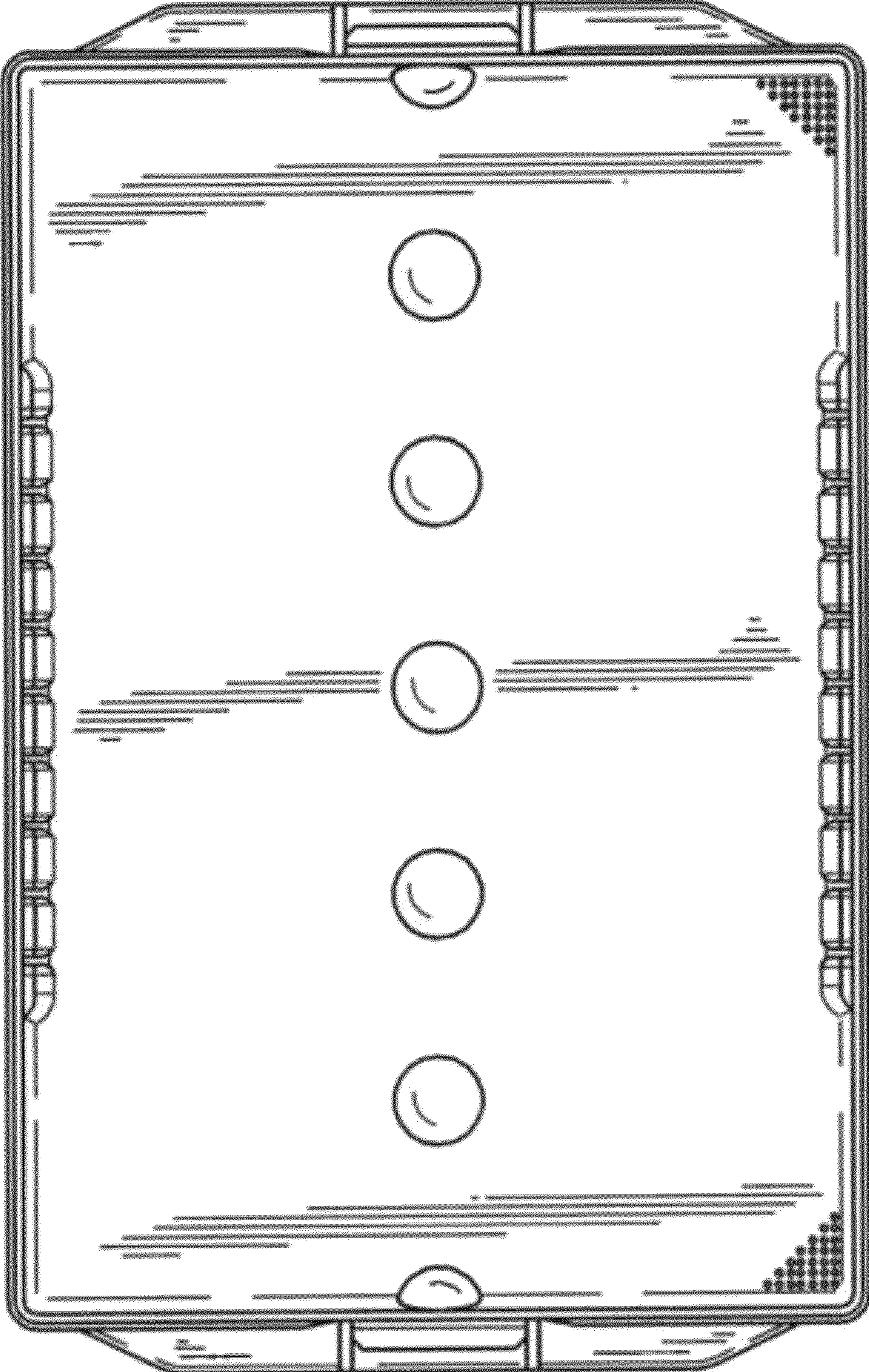

FIG. 7