



US00D660208S

(12) **United States Design Patent**
De Wind

(10) **Patent No.:** **US D660,208 S**
(45) **Date of Patent:** **** May 22, 2012**

(54) **VEHICULAR PRISMATIC MIRROR ASSEMBLY**

(75) Inventor: **Darryl P. De Wind**, West Olive, MI (US)

(73) Assignee: **Magna Mirrors of America, Inc.**, Holland, MI (US)

(**) Term: **14 Years**

(21) Appl. No.: **29/406,503**

(22) Filed: **Nov. 15, 2011**

Related U.S. Application Data

(63) Continuation-in-part of application No. PCT/US2011/056295, filed on Oct. 14, 2011.

(51) **LOC (9) Cl.** **12-16**

(52) **U.S. Cl.** **D12/187**

(58) **Field of Classification Search** D12/187, D12/188, 189; D6/300, 309; 359/838, 841-844, 359/868, 871, 604, 881, 514, 866; 248/475.1, 248/479-483

See application file for complete search history.

(56) **References Cited**

U.S. PATENT DOCUMENTS

5,669,698	A *	9/1997	Veldman et al.	362/494
5,671,996	A *	9/1997	Bos et al.	362/488
6,499,850	B2	12/2002	Waldmann	
D493,131	S	7/2004	Lawlor et al.	
D493,394	S	7/2004	Lawlor et al.	
6,983,920	B2 *	1/2006	DeLine	248/481
7,110,156	B2	9/2006	Lawlor et al.	
7,532,149	B2	5/2009	Banko et al.	
7,710,631	B2	5/2010	McCabe et al.	
7,821,697	B2	10/2010	Varaprasad et al.	
D633,019	S	2/2011	De Wind	
D633,423	S	3/2011	De Wind	
D638,761	S	5/2011	De Wind	
D647,017	S	10/2011	De Wind	
2002/0097494	A1 *	7/2002	Waldmann	359/603
2008/0266389	A1	10/2008	DeWind et al.	
2009/0207514	A1 *	8/2009	McCabe et al.	359/871
2009/0213480	A1	8/2009	Li	

2009/0237821	A1 *	9/2009	Li	359/844
2009/0244740	A1	10/2009	Takayanagi et al.	
2010/0085645	A1	4/2010	Skiver et al.	
2010/0091394	A1 *	4/2010	DeWind et al.	359/838
2010/0290141	A1 *	11/2010	Huang	359/844
2010/0321758	A1	12/2010	Bugno et al.	

FOREIGN PATENT DOCUMENTS

WO	WO2010124064	10/2010
WO	WO2011044312	4/2011

* cited by examiner

Primary Examiner — Caron D Veynar

Assistant Examiner — Katrina Kile

(74) *Attorney, Agent, or Firm* — Gardner, Linn, Burkhardt & Flory, LLP

(57) **CLAIM**

The ornamental design for a vehicular prismatic mirror assembly, as shown and described.

DESCRIPTION

FIG. 1 is a front perspective view of a vehicular prismatic mirror assembly in accordance with the present invention; FIG. 2 is a rear perspective view of the vehicular prismatic mirror assembly of FIG. 1; FIG. 3 is a front elevation of the vehicular prismatic mirror assembly of FIG. 1; FIG. 4 is a rear elevation of the vehicular prismatic mirror assembly of FIG. 1; FIG. 5 is a side elevation of the vehicular prismatic mirror assembly of FIG. 1; FIG. 6 is an opposite side elevation of the vehicular prismatic mirror assembly of FIG. 1; FIG. 7 is a top plan view of the vehicular prismatic mirror assembly of FIG. 1; FIG. 8 is a bottom plan view of the vehicular prismatic mirror assembly of FIG. 1; FIG. 9 is a front perspective view of a second embodiment of a vehicular prismatic mirror assembly in accordance with the present invention; FIG. 10 is a rear perspective view of the vehicular prismatic mirror assembly of FIG. 9;

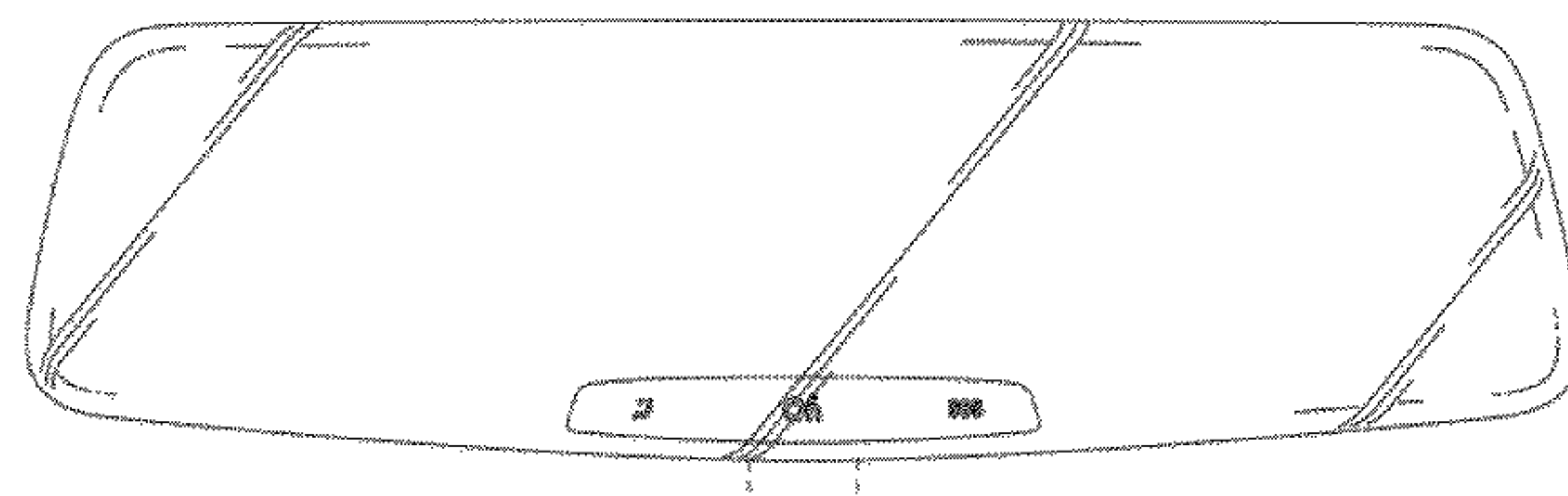
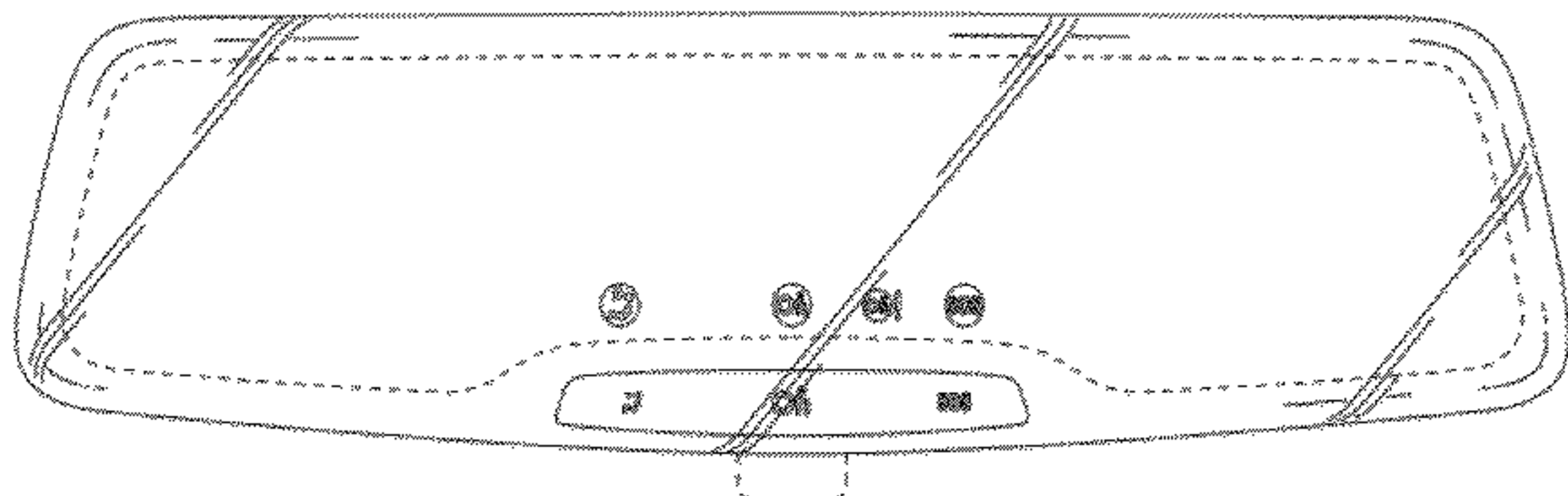

FIG. 11 is a front elevation of the vehicular prismatic mirror assembly of FIG. 9;
FIG. 12 is a rear elevation of the vehicular prismatic mirror assembly of FIG. 9;
FIG. 13 is a side elevation of the vehicular prismatic mirror assembly of FIG. 9;
FIG. 14 is an opposite side elevation of the vehicular prismatic mirror assembly of FIG. 9;
FIG. 15 is a top plan view of the vehicular prismatic mirror assembly of FIG. 9;
FIG. 16 is a bottom plan view of the vehicular prismatic mirror assembly of FIG. 9;
FIG. 17 is a front perspective view of a third embodiment of a vehicular prismatic mirror assembly in accordance with the present invention;
FIG. 18 is a rear perspective view of the vehicular prismatic mirror assembly of FIG. 17;
FIG. 19 is a front elevation of the vehicular prismatic mirror assembly of FIG. 17;
FIG. 20 is a rear elevation of the vehicular prismatic mirror assembly of FIG. 17;
FIG. 21 is a side elevation of the vehicular prismatic mirror assembly of FIG. 17;
FIG. 22 is an opposite side elevation of the vehicular prismatic mirror assembly of FIG. 17;

FIG. 23 is a top plan view of the vehicular prismatic mirror assembly of FIG. 17;
FIG. 24 is a bottom plan view of the vehicular prismatic mirror assembly of FIG. 17;
FIG. 25 is a front perspective view of a fourth embodiment of a vehicular prismatic mirror assembly in accordance with the present invention;
FIG. 26 is a rear perspective view of the vehicular prismatic mirror assembly of FIG. 25;
FIG. 27 is a front elevation of the vehicular prismatic mirror assembly of FIG. 25;
FIG. 28 is a rear elevation of the vehicular prismatic mirror assembly of FIG. 25;
FIG. 29 is a side elevation of the vehicular prismatic mirror assembly of FIG. 25;
FIG. 30 is an opposite side elevation of the vehicular prismatic mirror assembly of FIG. 25;
FIG. 31 is a top plan view of the vehicular prismatic mirror assembly of FIG. 25; and,
FIG. 32 is a bottom plan view of the vehicular prismatic mirror assembly of FIG. 25.
In the drawings, the broken lines in the figures depict portions of the design that form no part of the claim.

1 Claim, 20 Drawing Sheets

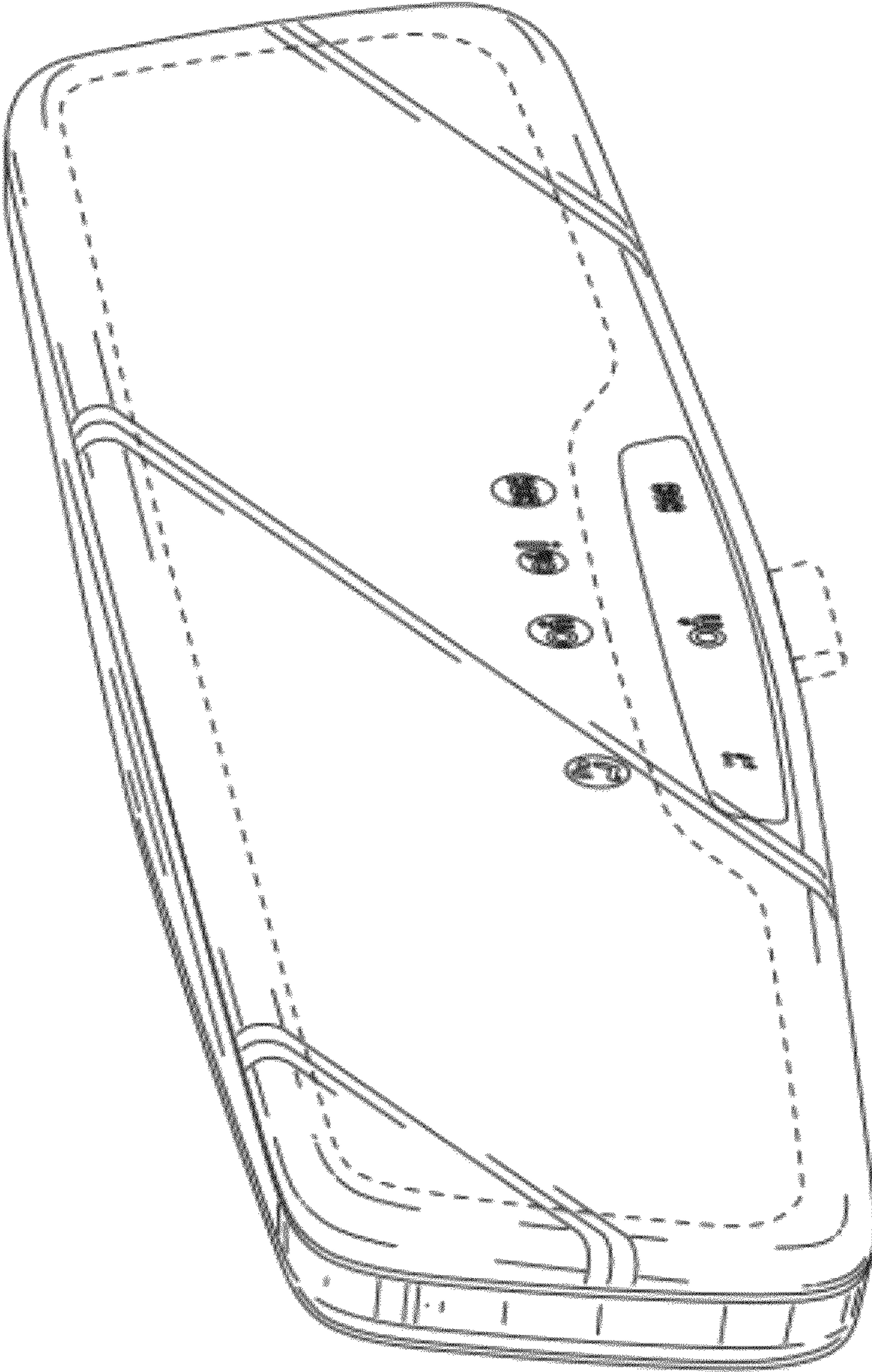

FIG. 1

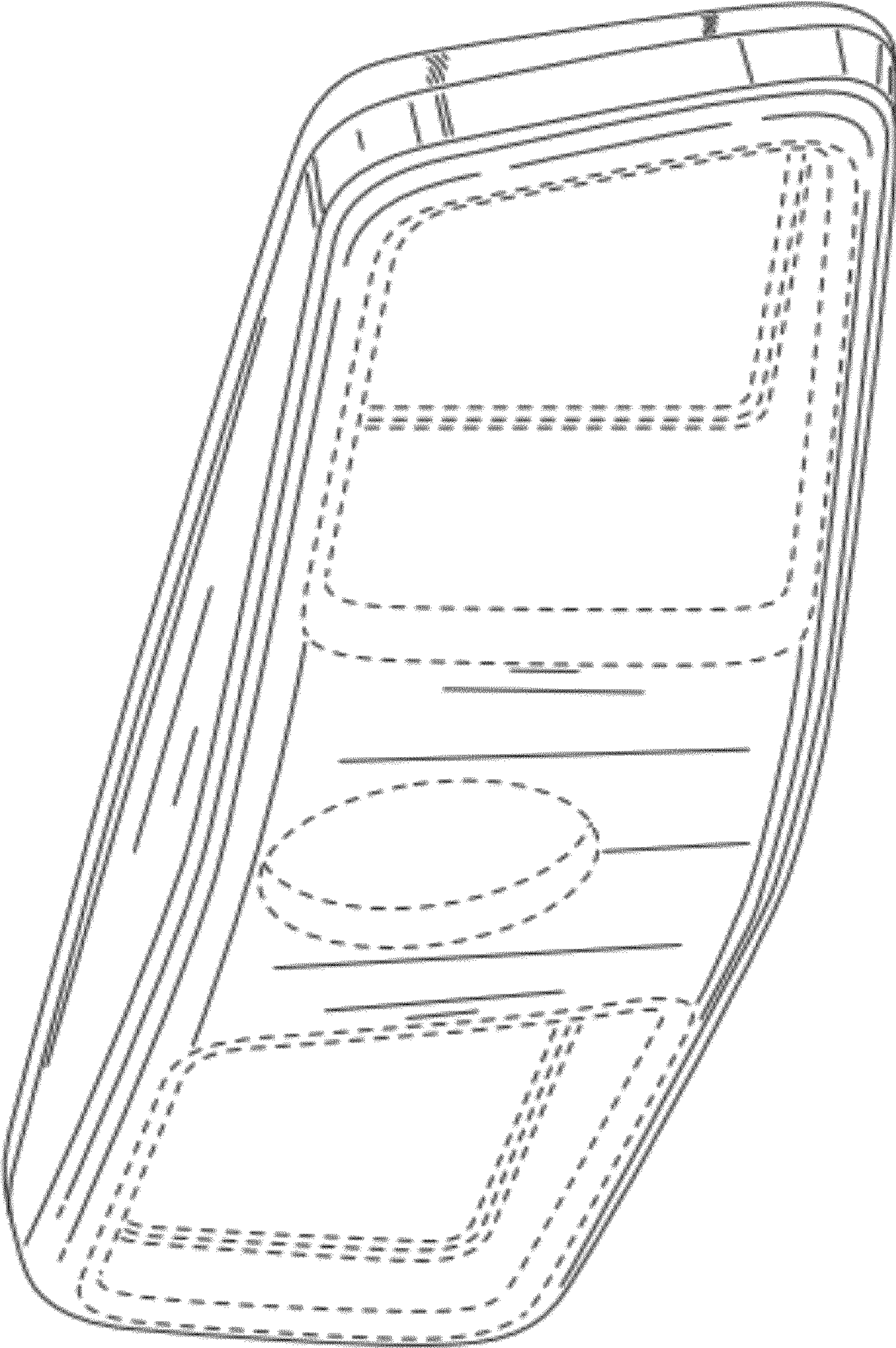

FIG. 2

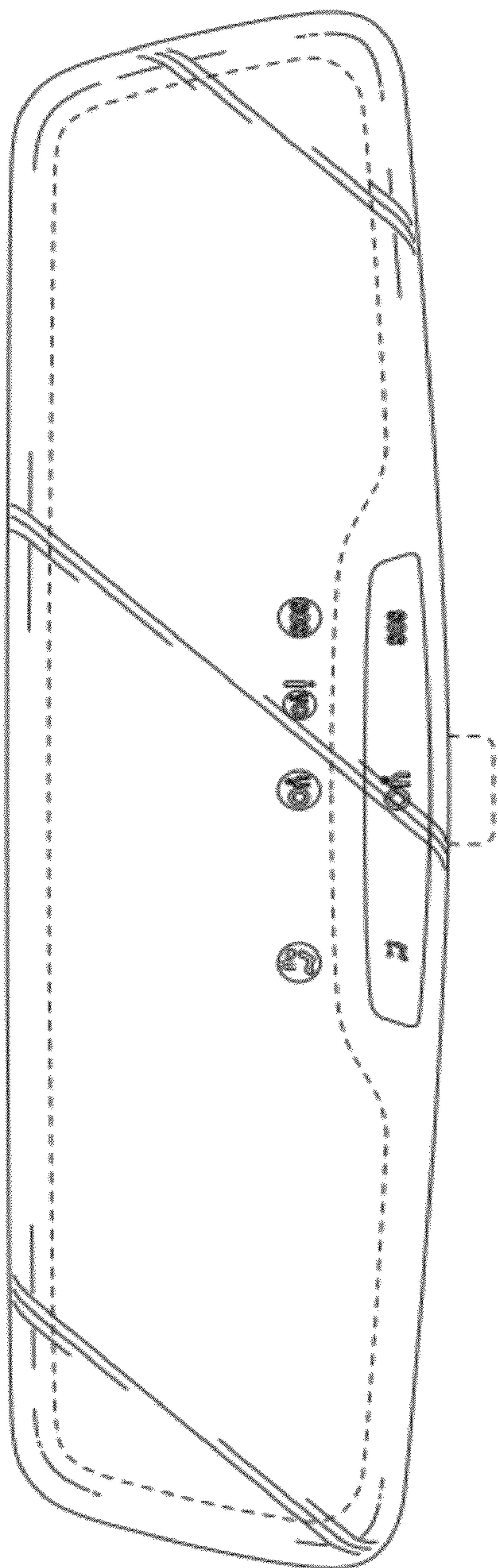

FIG. 3

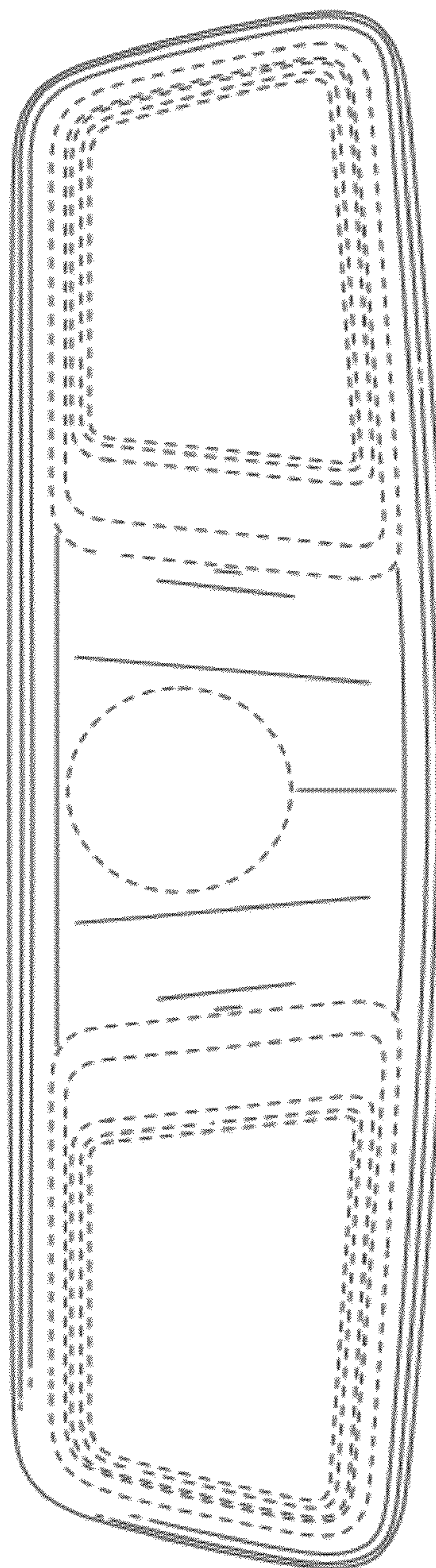

FIG. 4

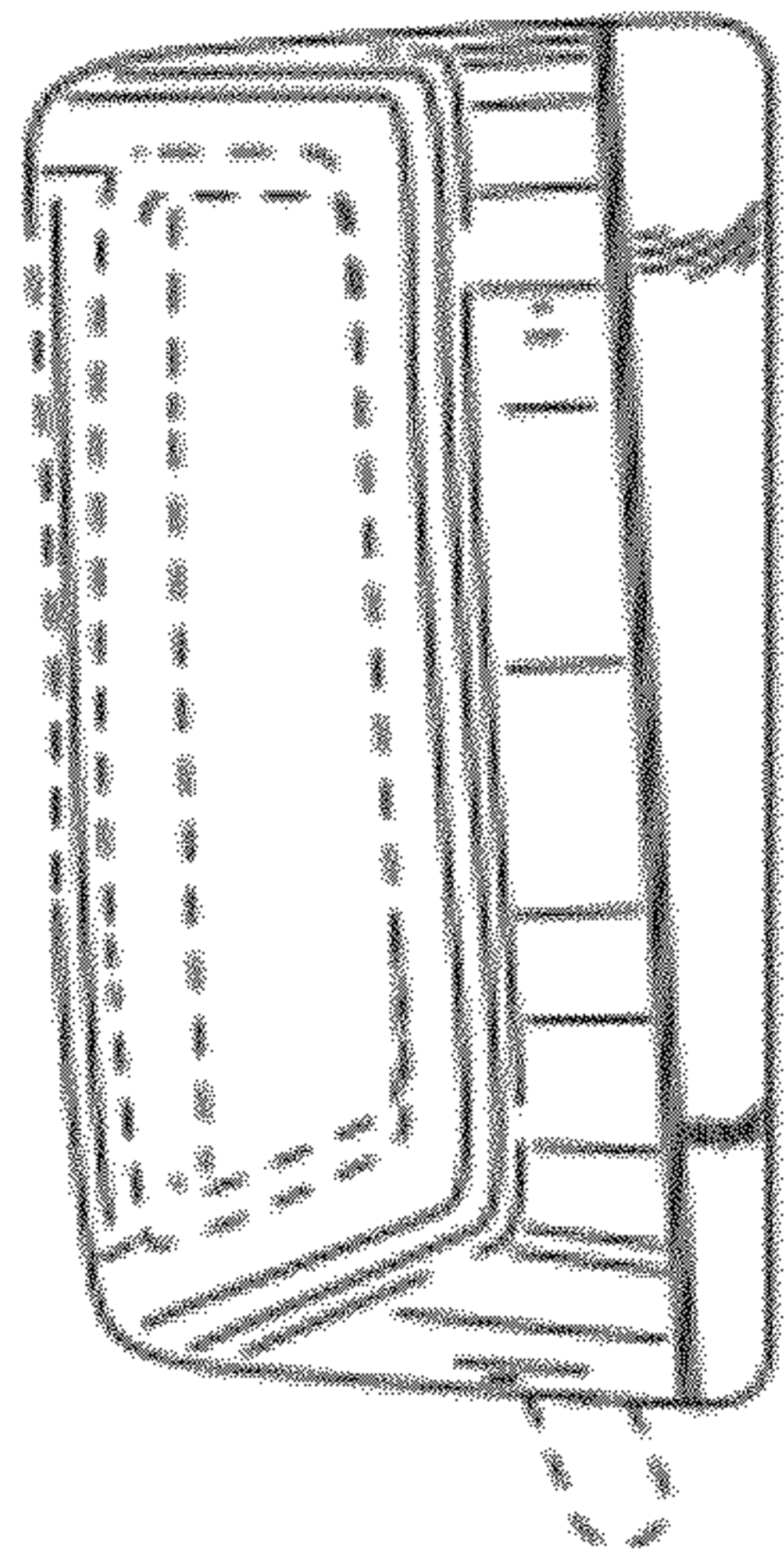

FIG. 5

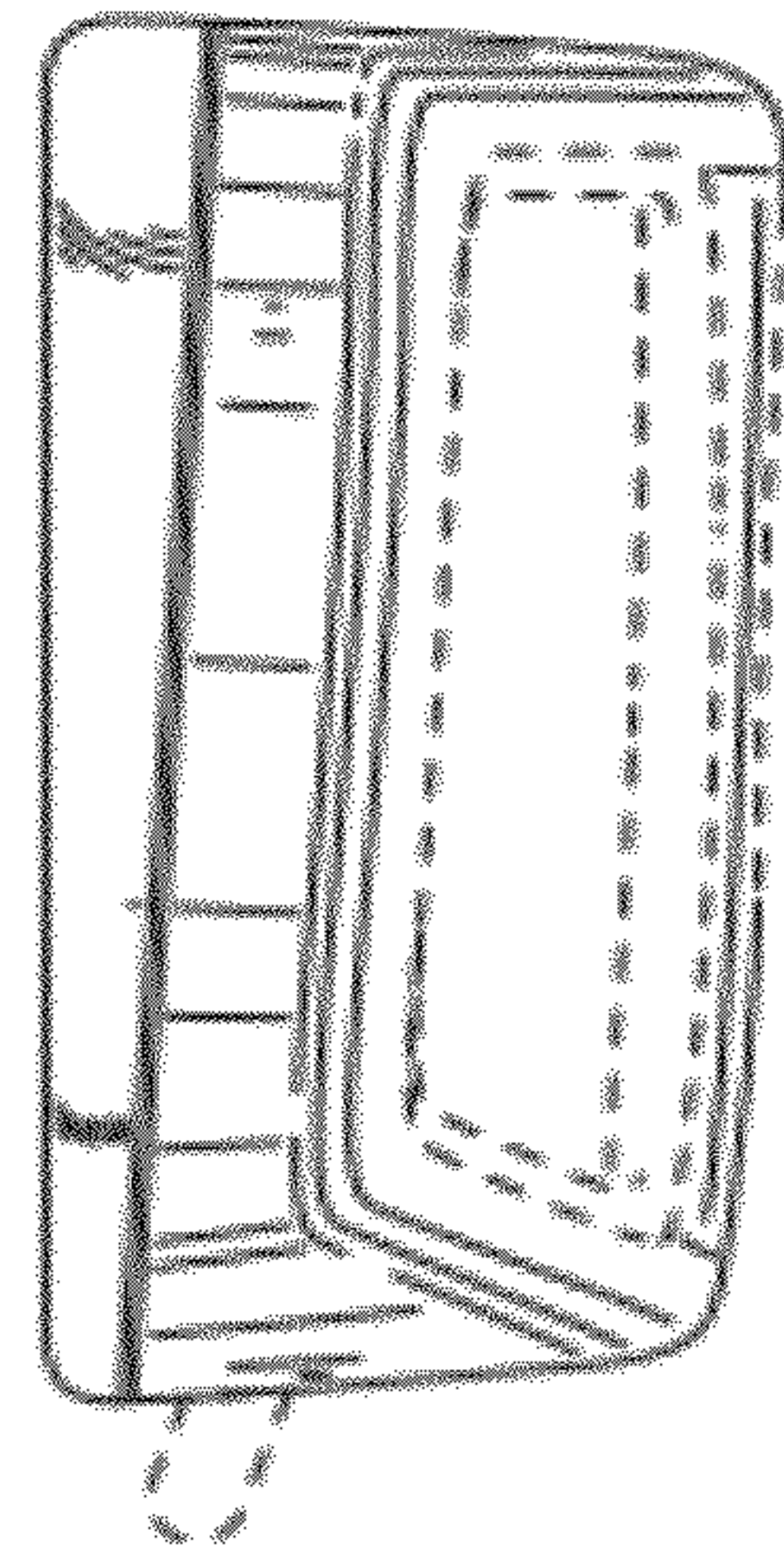

FIG. 6

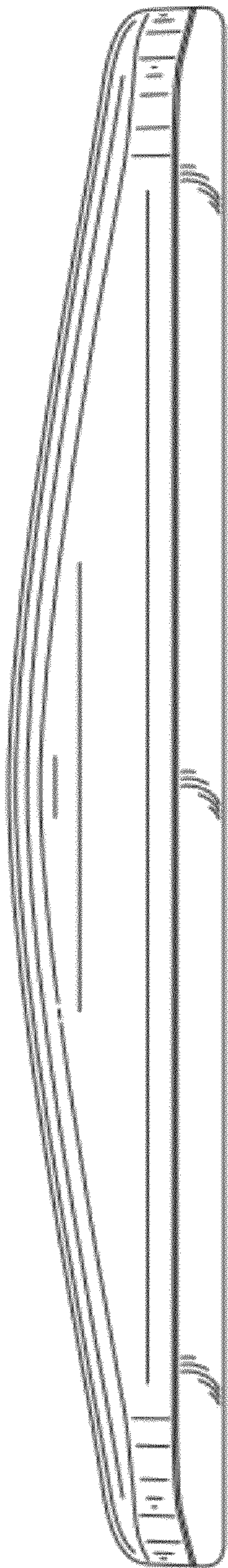

FIG. 7

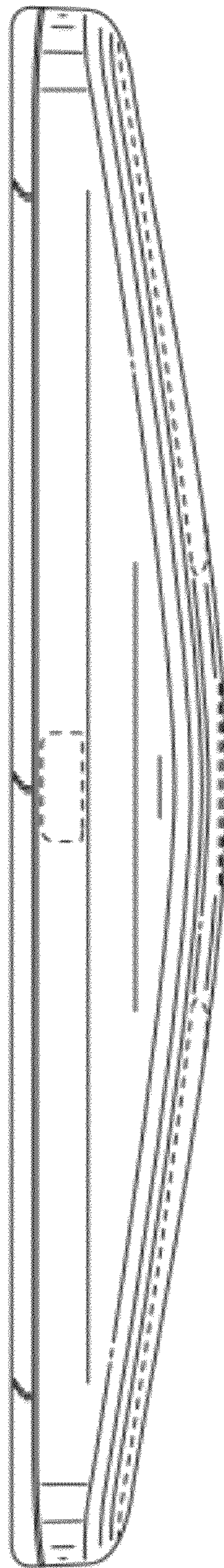

FIG. 8

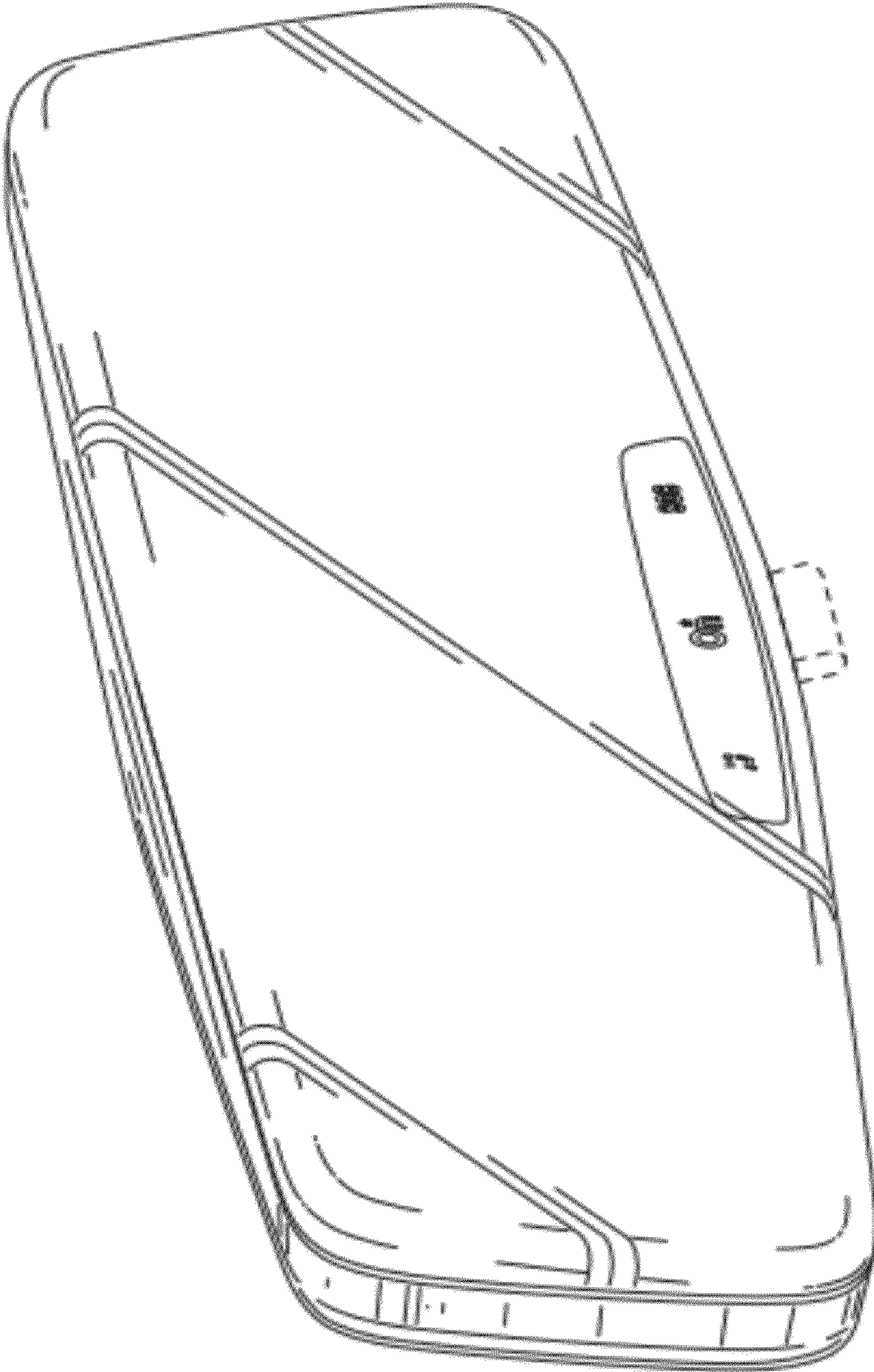

FIG. 9

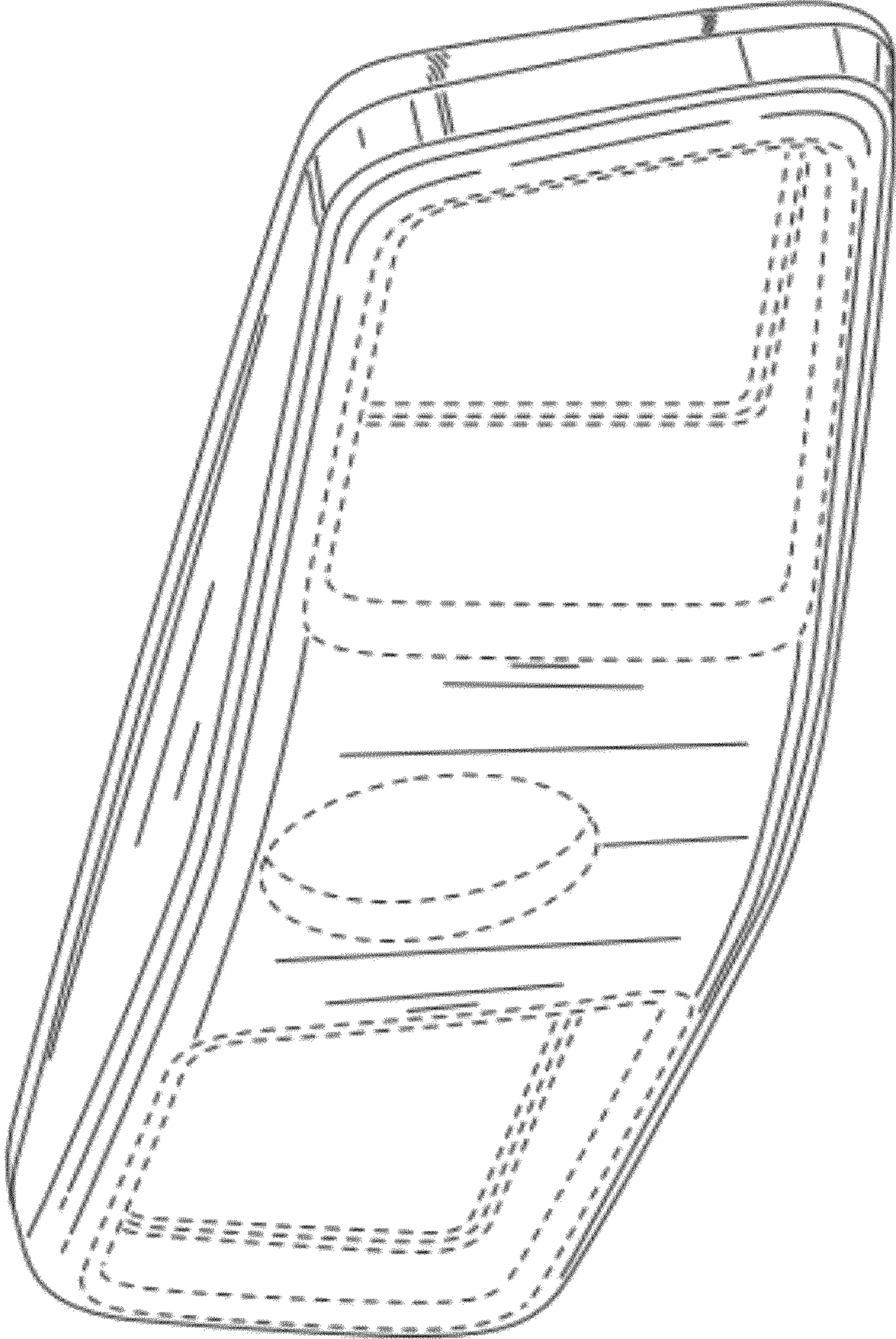

FIG. 10

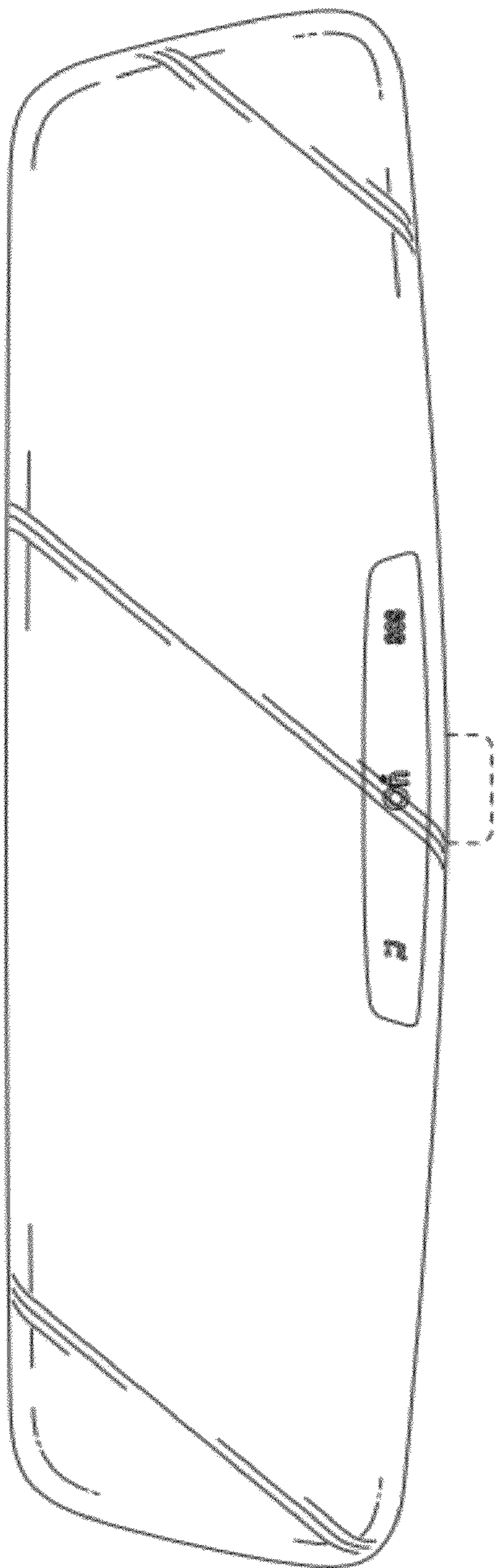

FIG. 11

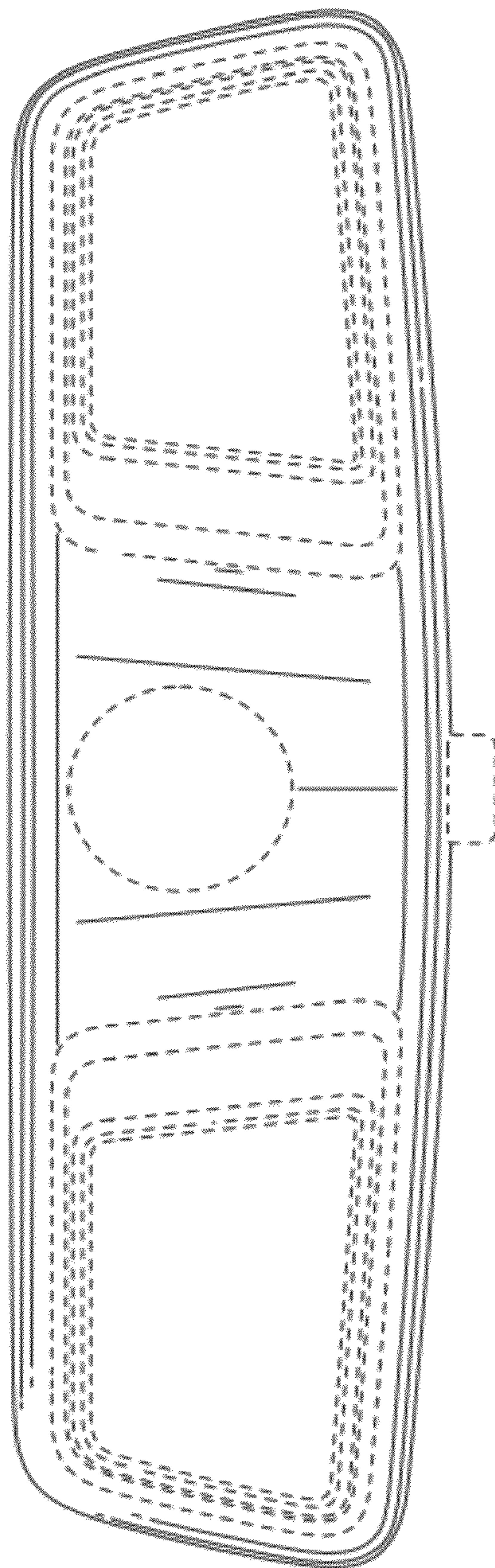

FIG. 12

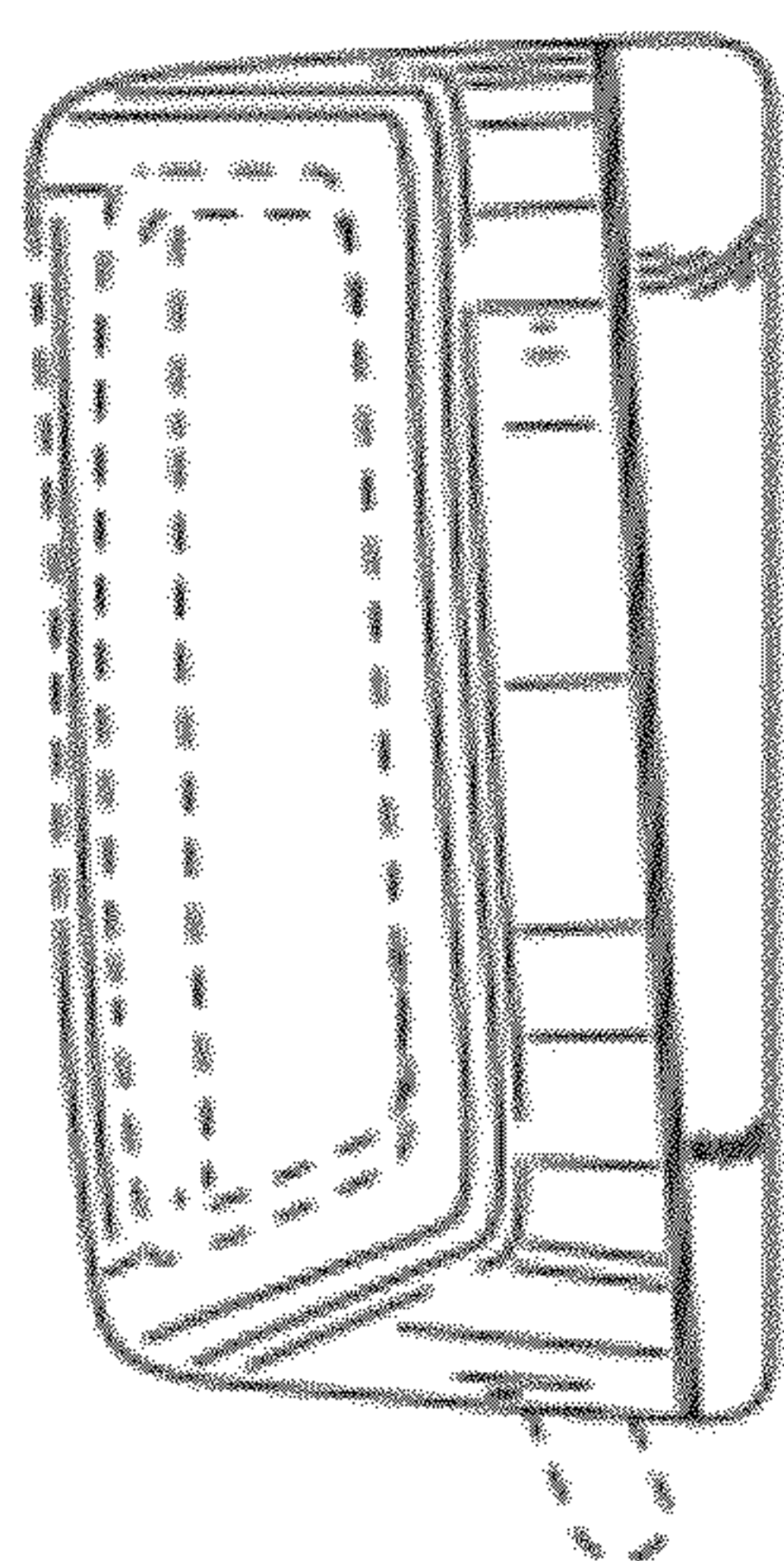

FIG. 13

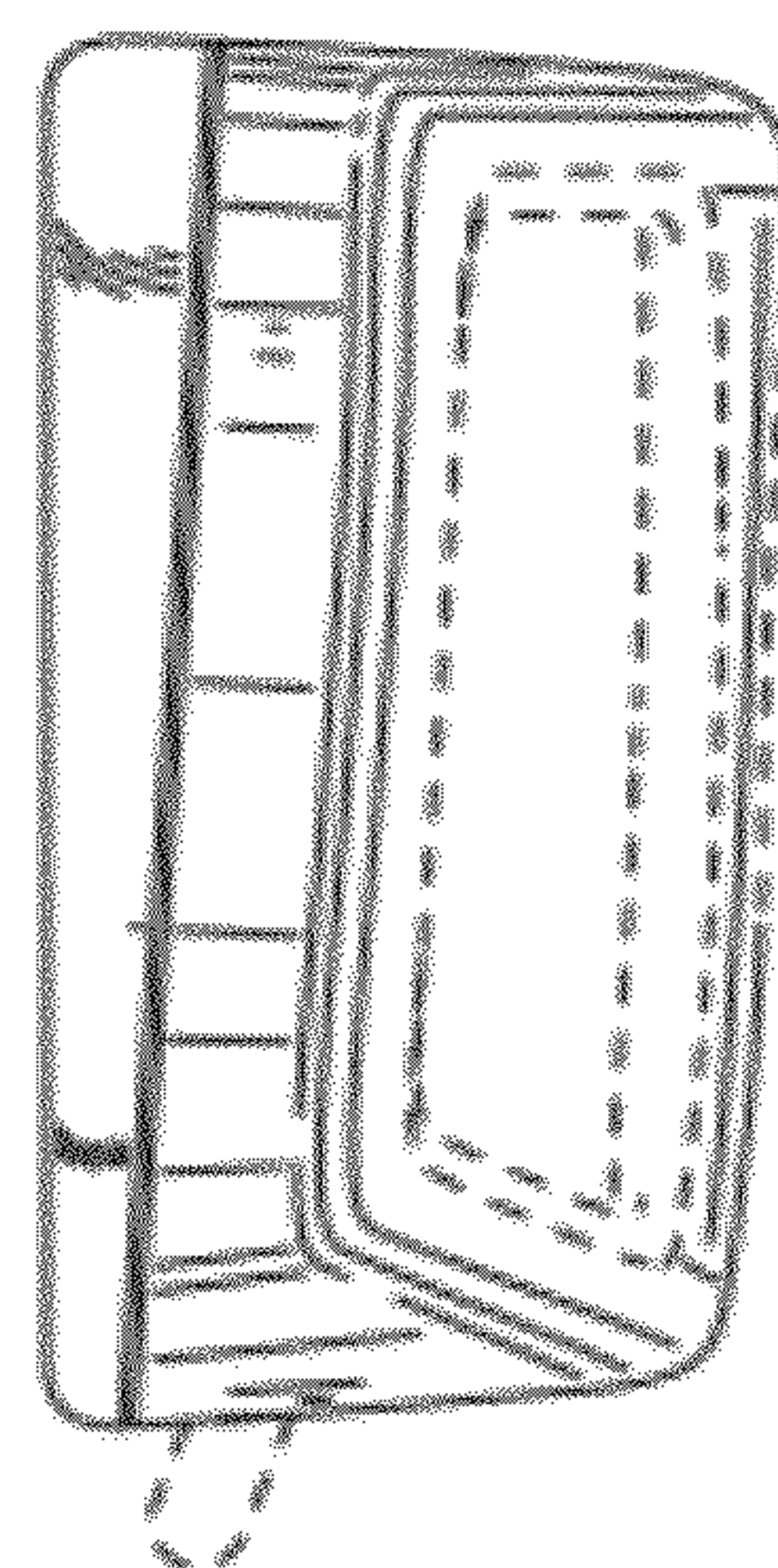

FIG. 14

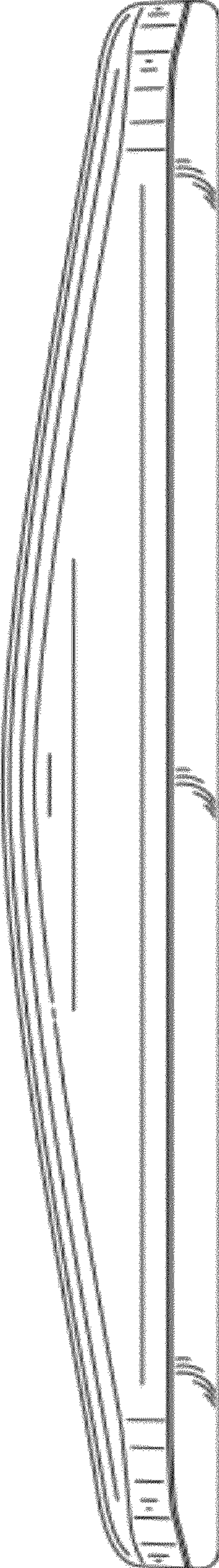

FIG. 15

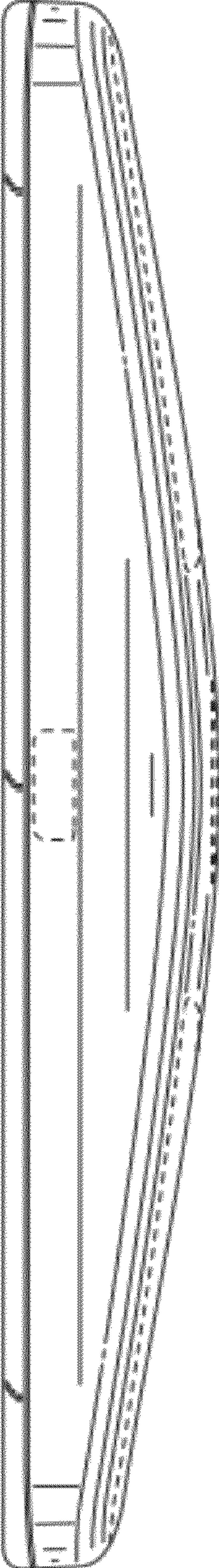

FIG. 16

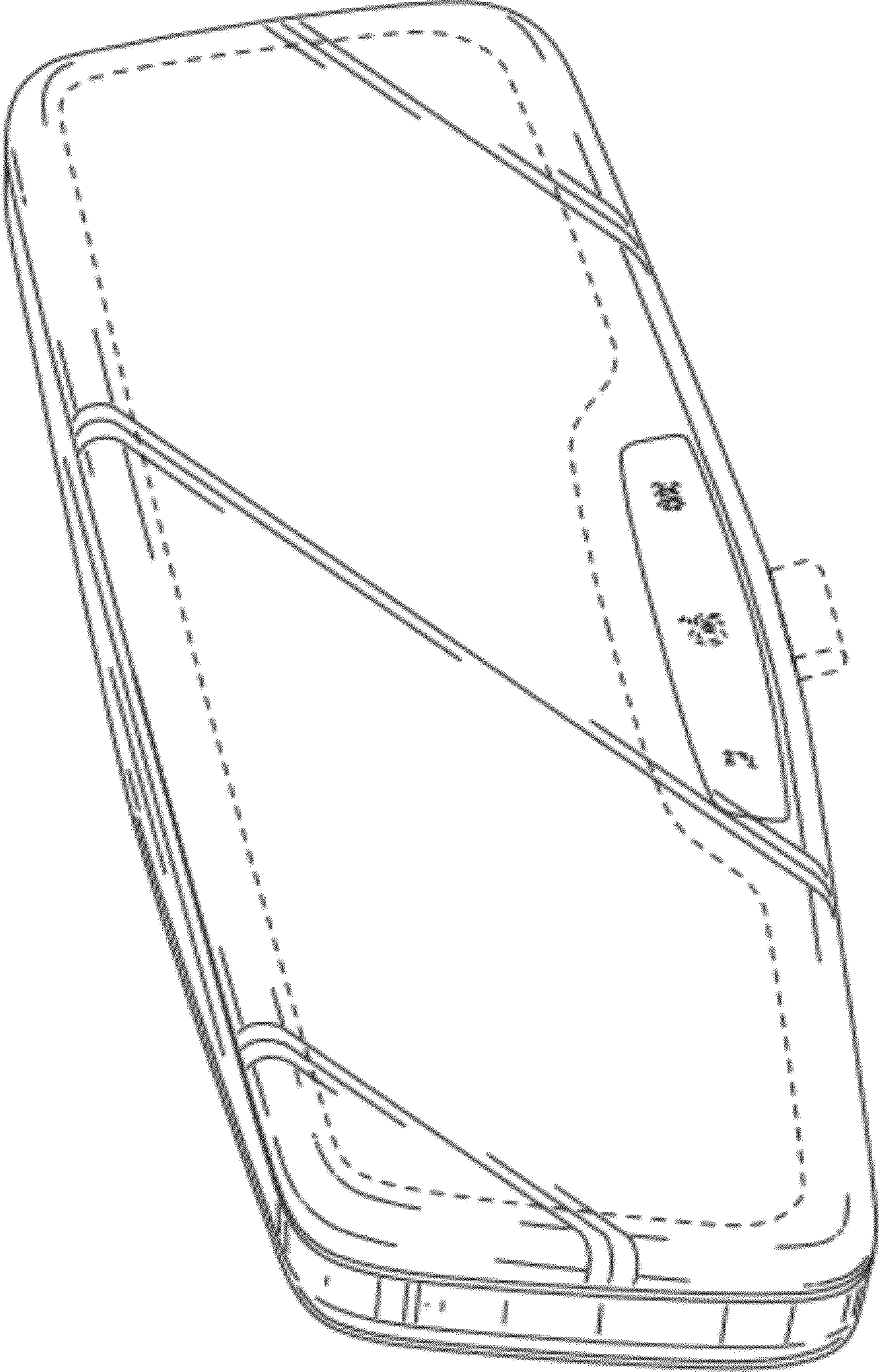

FIG. 17

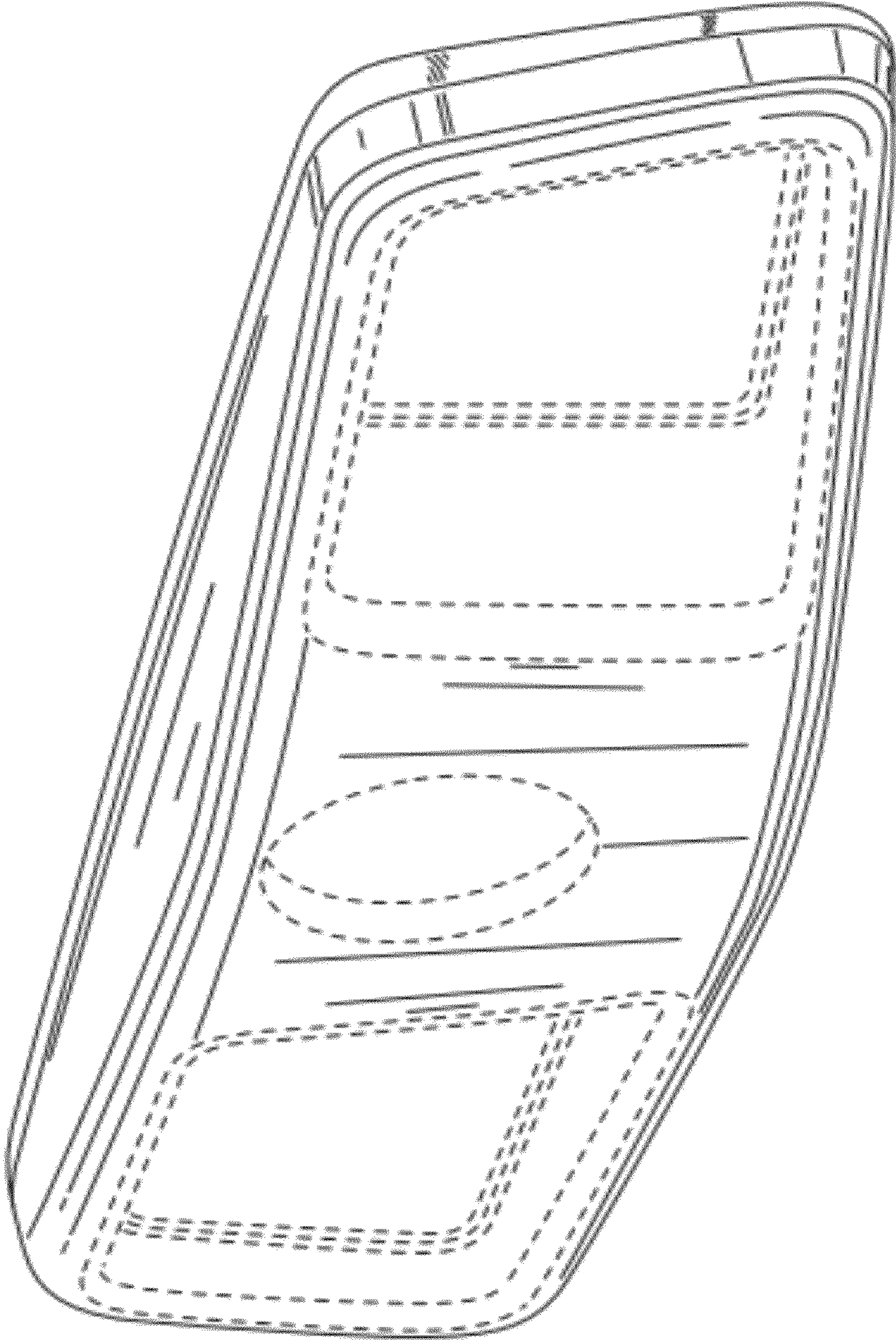

FIG. 18

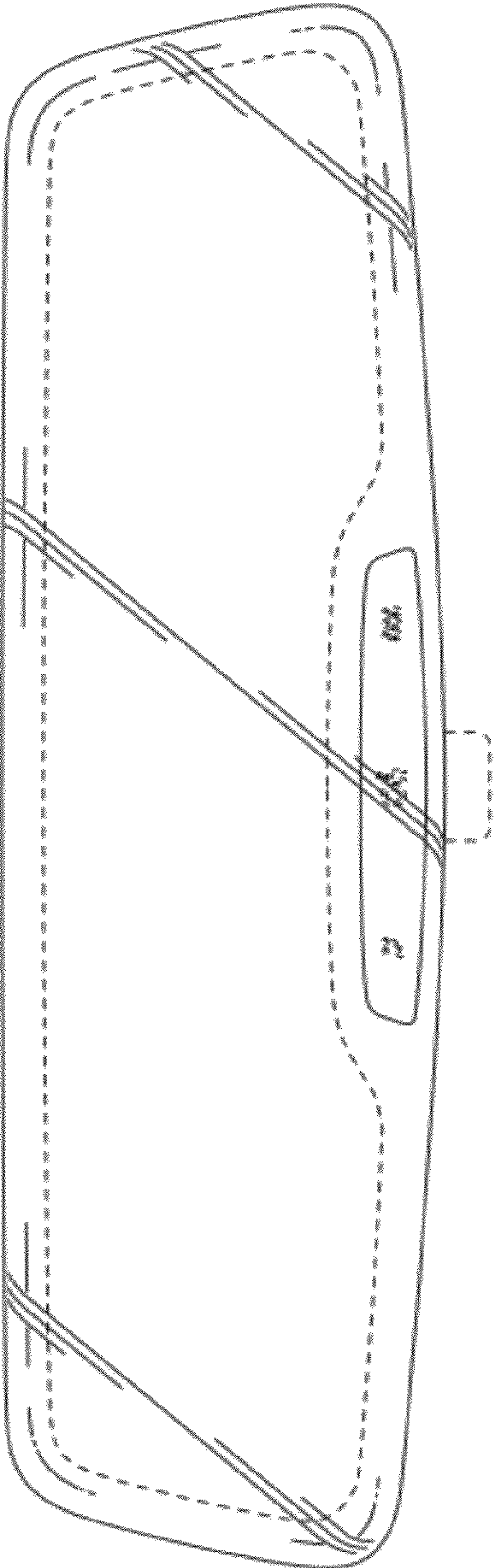

FIG. 19

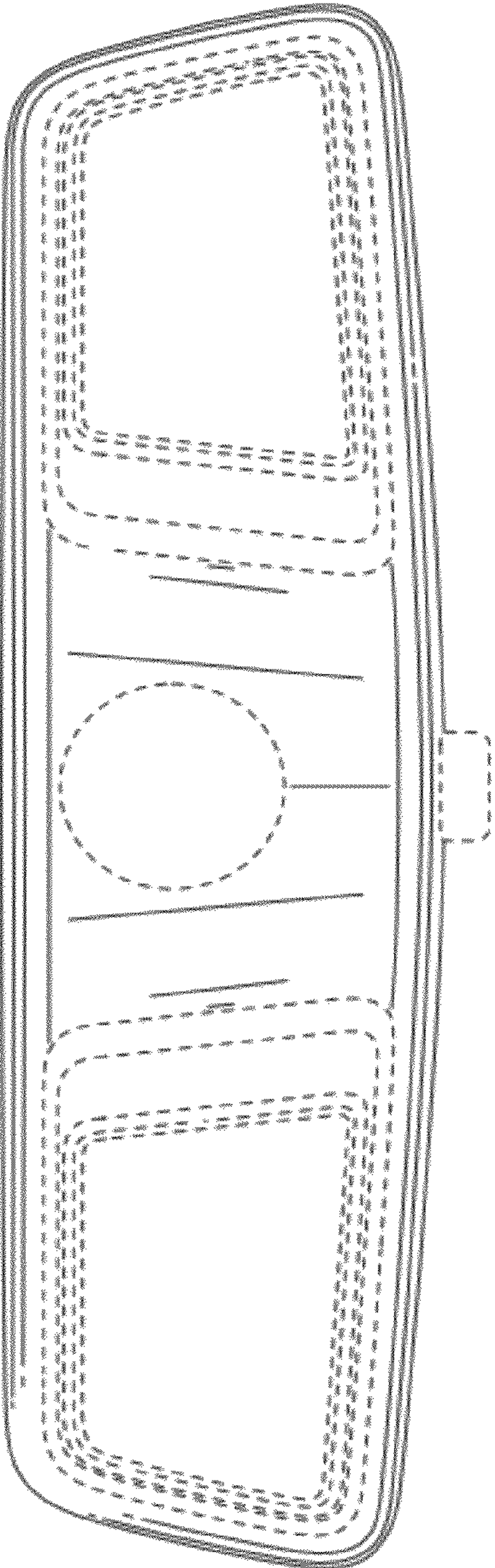

FIG. 20

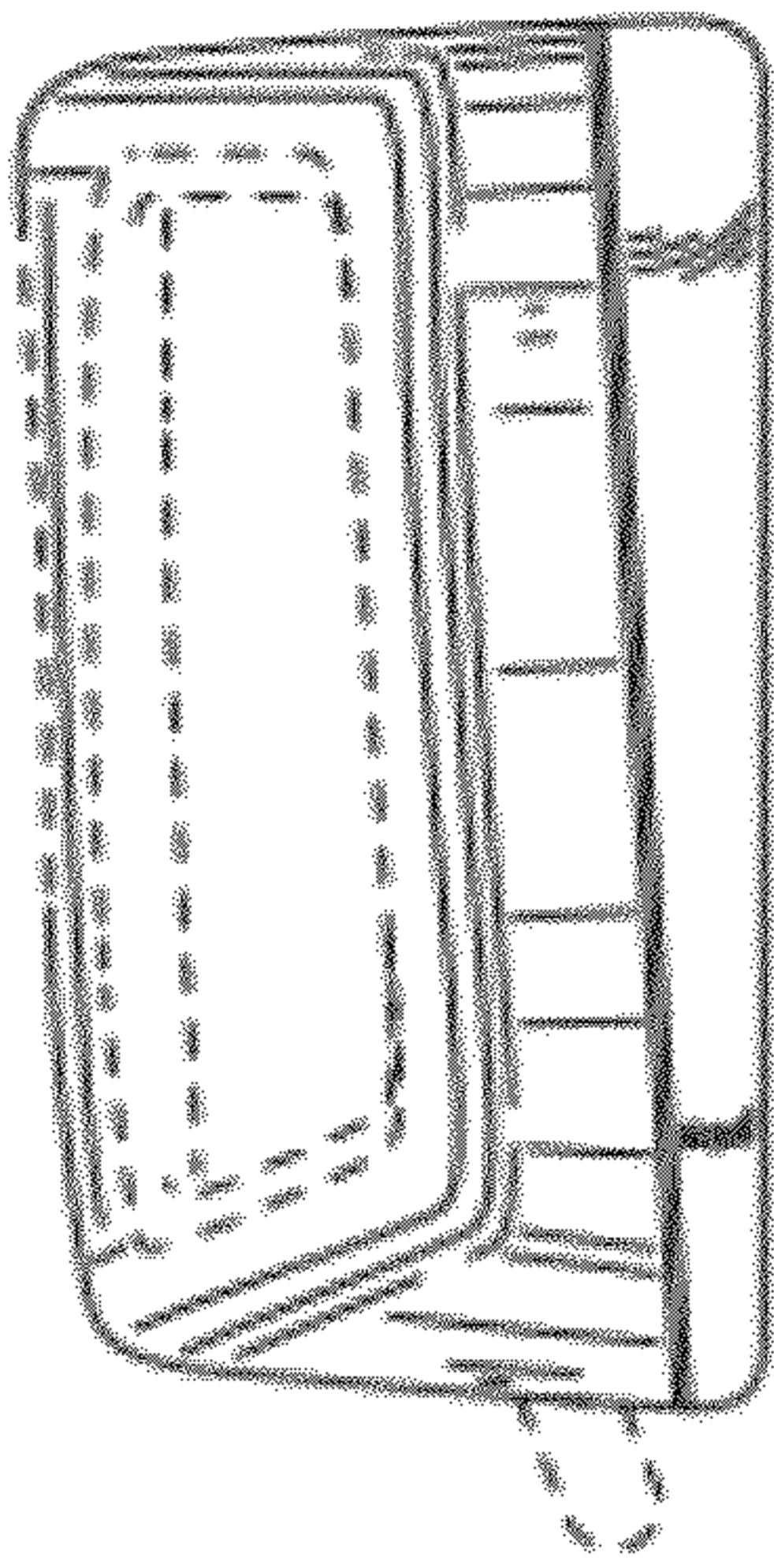

FIG. 21

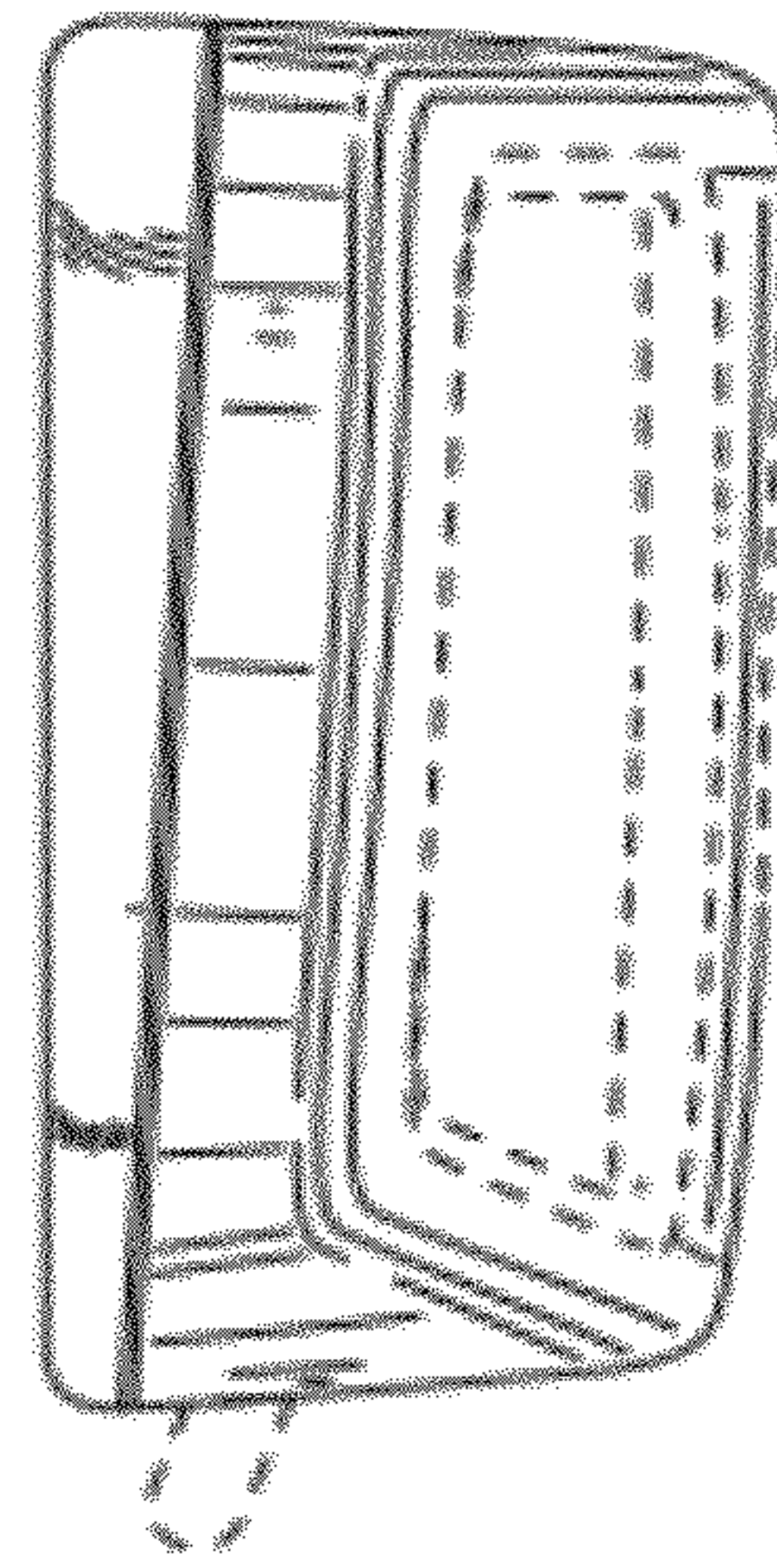

FIG. 22

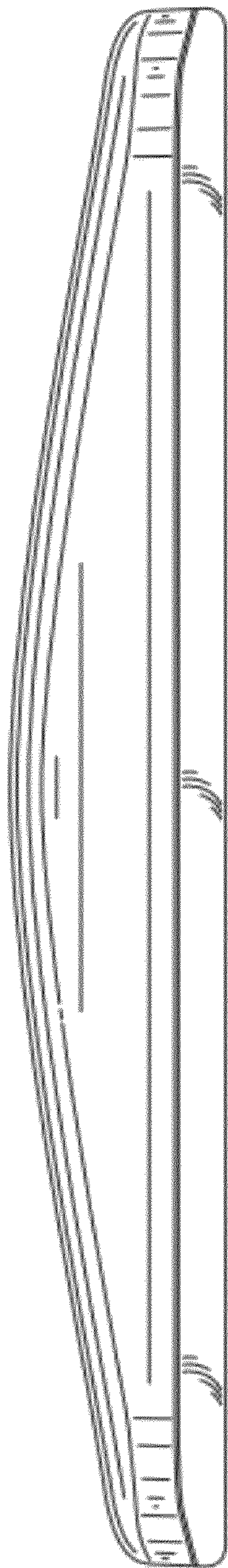

FIG. 23

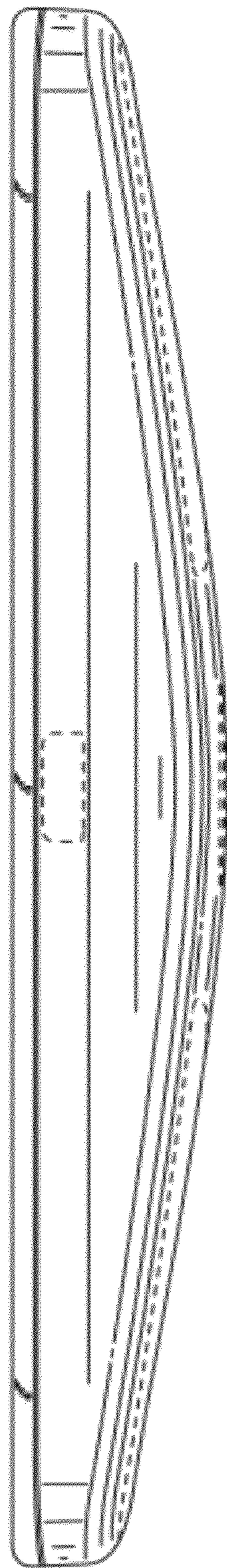

FIG. 24

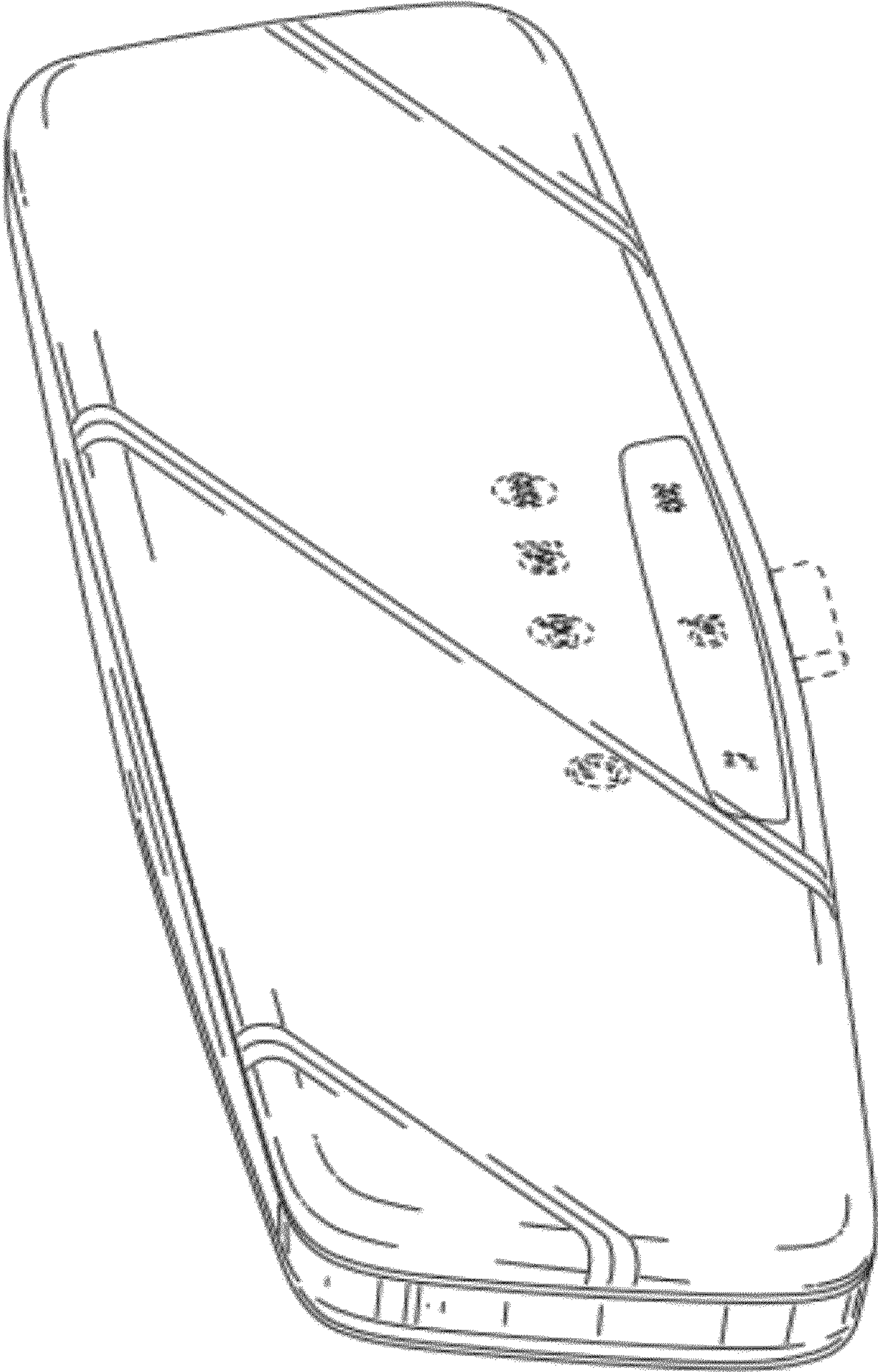

FIG. 25

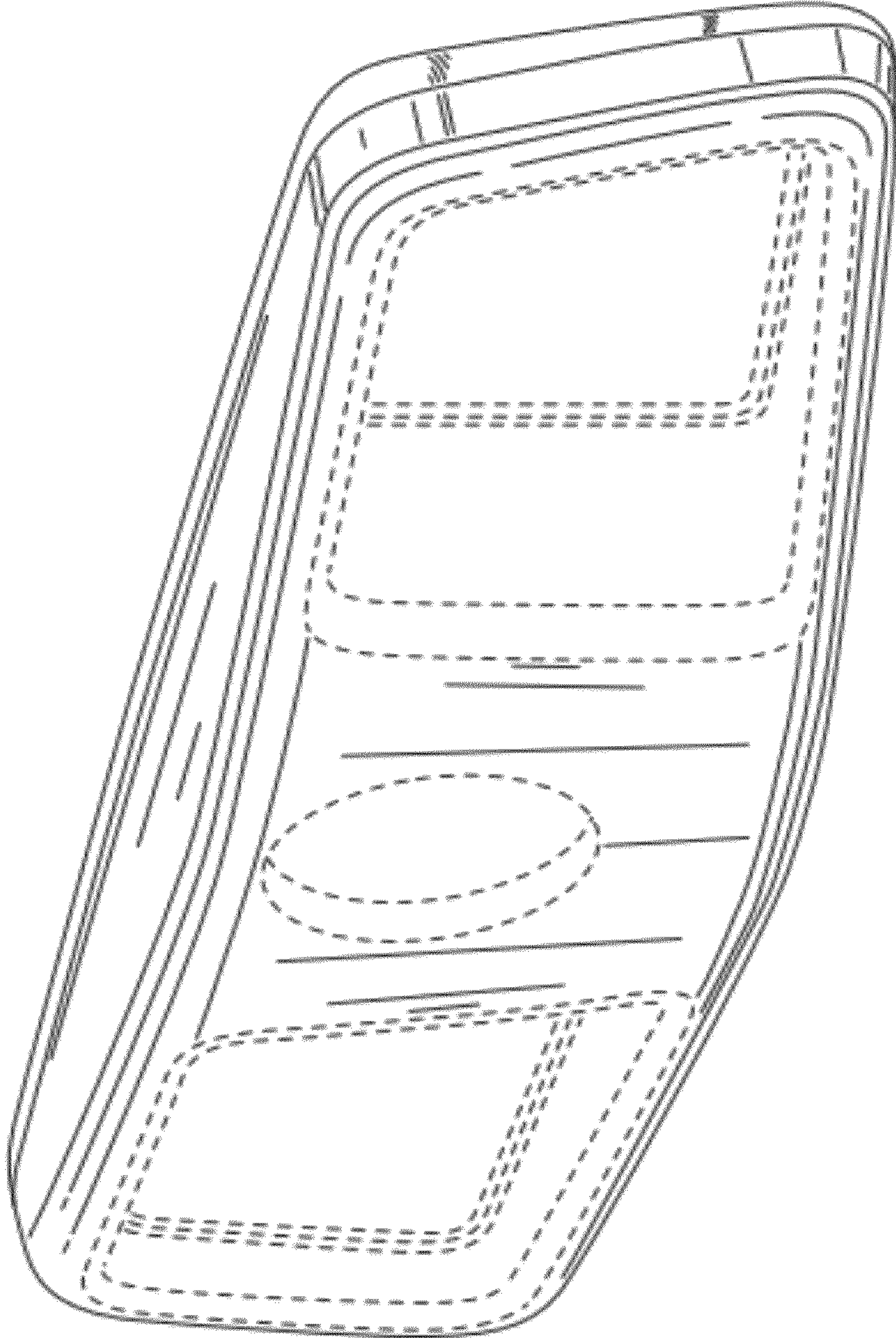

FIG. 26

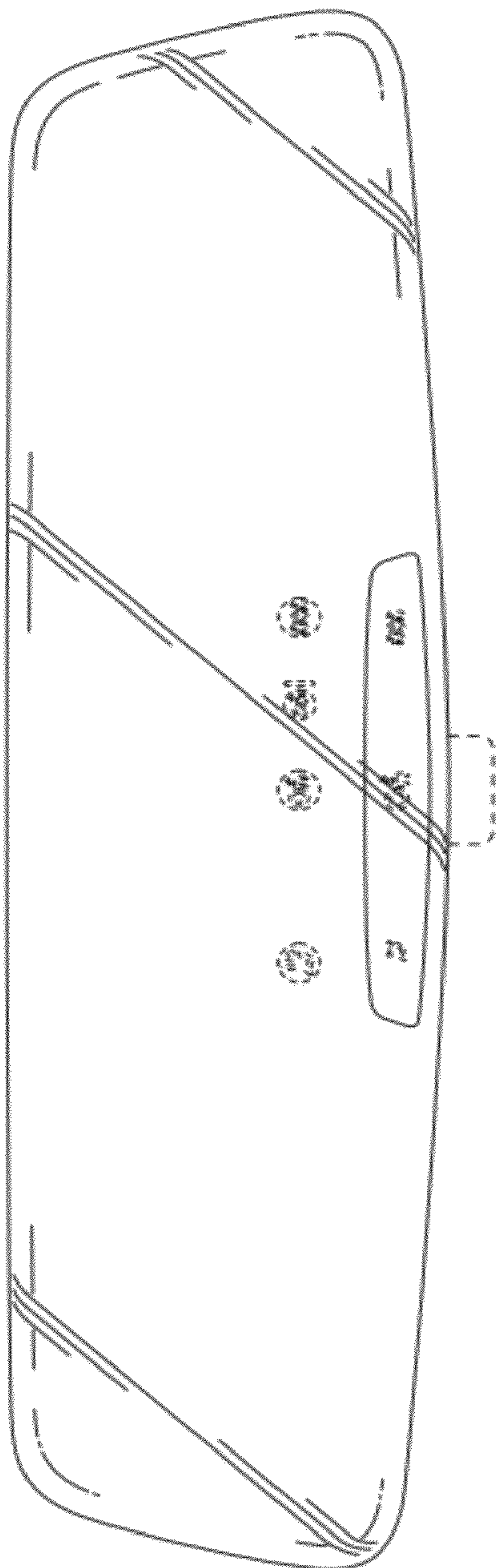

FIG. 27

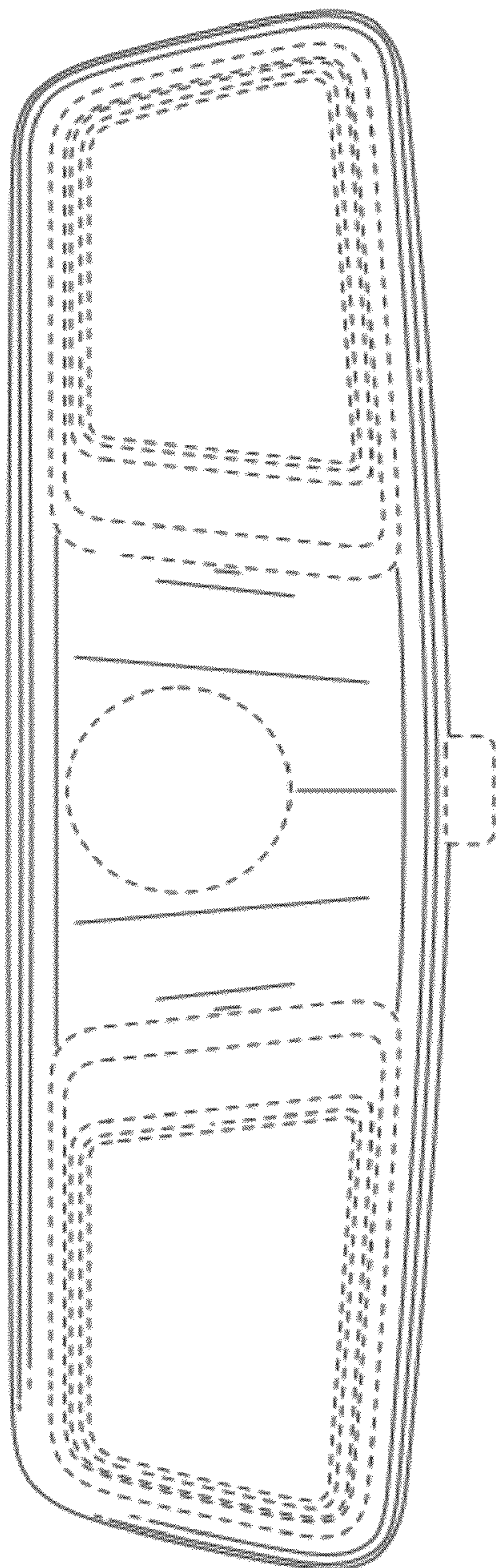

FIG. 28

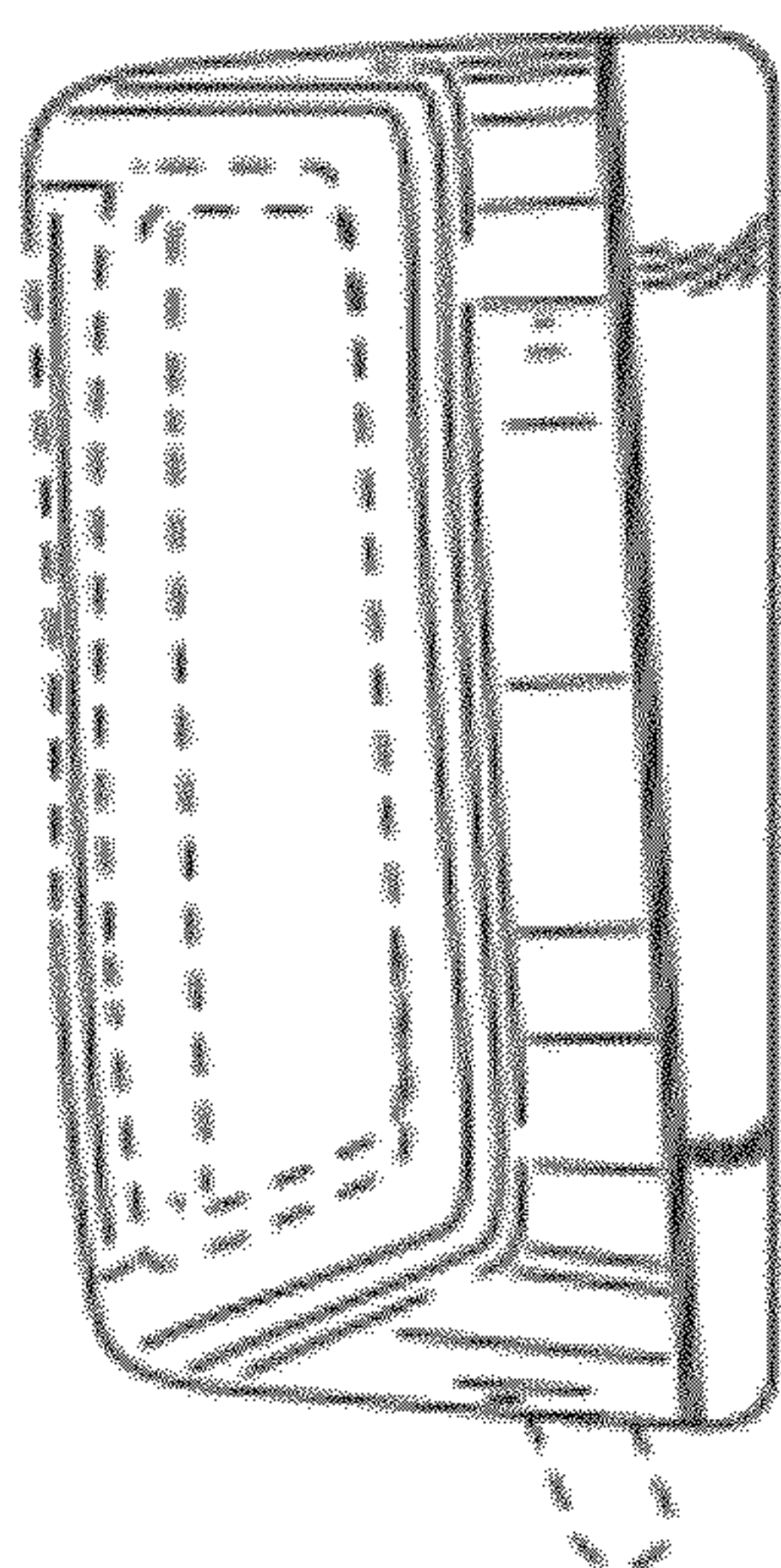

FIG. 29

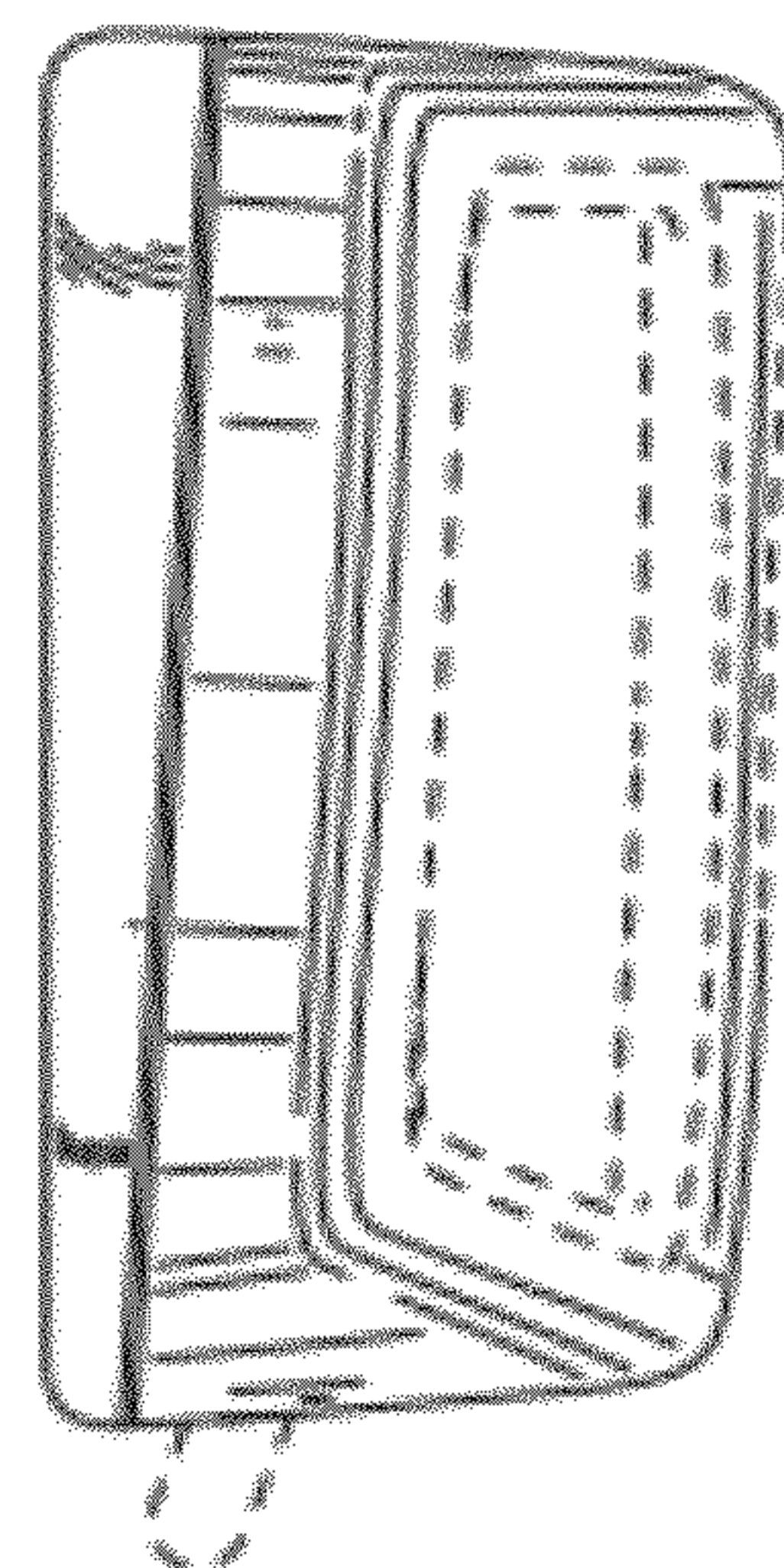

FIG. 30

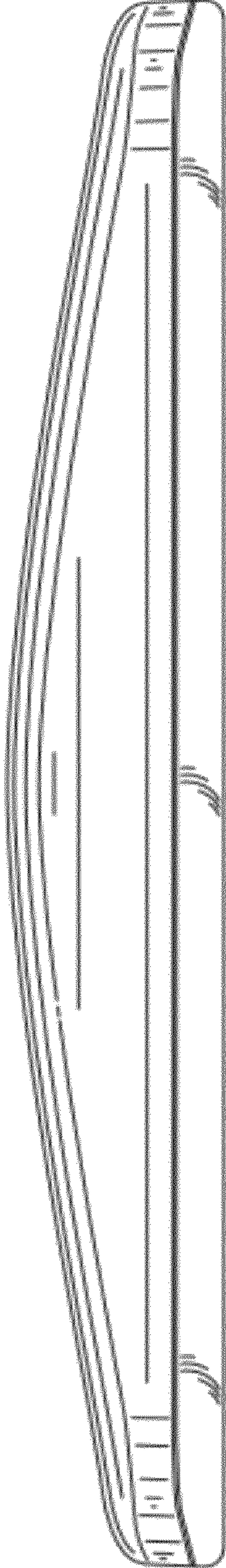

FIG. 31

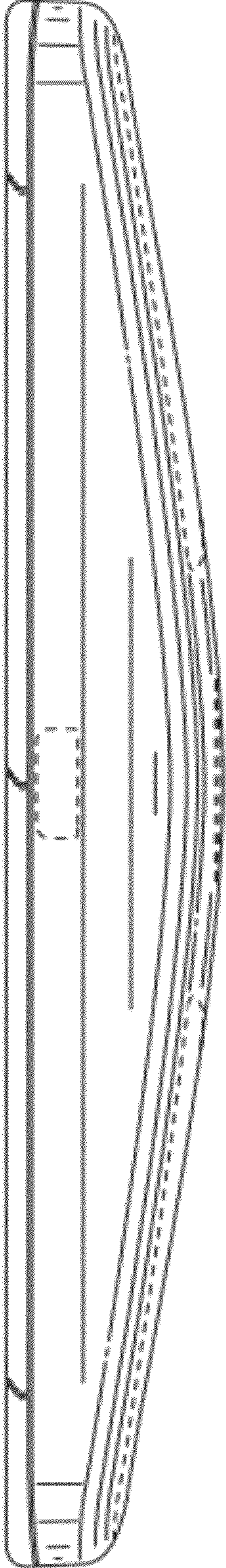

FIG. 32