



US00D660200S

(12) **United States Design Patent**
Fitzpatrick et al.

(10) **Patent No.:** **US D660,200 S**
(45) **Date of Patent:** **** May 22, 2012**

(54) **MOTORCYCLE BODY**

(75) Inventors: **Richard Fitzpatrick**, Longmont, CO (US); **Michael T. Mayberry**, Denver, CO (US); **Eric Christopher Burt**, Flowery Branch, GA (US); **Grady Barfoot**, Denver, CO (US)

(73) Assignee: **Ronin Motor Works, LLC**, Denver, CO (US)

(**) Term: **14 Years**

(21) Appl. No.: **29/378,511**

(22) Filed: **Nov. 5, 2010**

(51) **LOC (9) Cl.** **12-11**

(52) **U.S. Cl.** **D12/110**

(58) **Field of Classification Search** D12/110,
D12/114, 117; 180/219, 220; 296/77.1,
296/78.1, 181.1, 187.01, 187.12, 192, 193.04;
280/288.2

See application file for complete search history.

(56) **References Cited**

U.S. PATENT DOCUMENTS

D606,907 S * 12/2009 Arai et al. D12/110

OTHER PUBLICATIONS

Vincent Black Shadow, Series C, circa 1949 on p. 1 of 2. [Retrieved on Sep. 14, 2011]. Retrieved from the Internet <URL: http://en.wikipedia.org/wiki/Vincent_Black_Shadow>.*

Magpul Ronin motorcycle, dated Oct. 13, 2010. [Retrieved on Sep. 14, 2011]. Retrieved from the Internet <URL: <http://tumblr.infinity-dimensions.com/post/1305361025/8-incredible-motorcycle-to-wrap-y...>>.*

Confederate_Motorcycles_2007_Confederate_Wraith Confederate Motorcycles (2007) Confederate Wraith; Website [Online] Avail-

able Web Site: <http://confederate.com/motorcycles/wraith/>; Last Update: Unknown; Accessed on: Apr. 1, 2011.

Confederate_Motorcycles_2008_Confederate_Fighter Confederate Motorcycles (2007) Confederate Fighter; Website [Online] Available Web Site: <http://confederate.com/motorcycles/fighter/>; Last Update: Unknown; Accessed on: Apr. 1, 2011.

(Continued)

Primary Examiner — Philip S Hyder

Assistant Examiner — Linda G. Brooks

(74) *Attorney, Agent, or Firm* — Swanson & Bratschun, L.L.C.

(57) **CLAIM**

The ornamental design for a motorcycle body, as shown and described.

DESCRIPTION

FIG. 1 is a right side elevation view our motorcycle body shown mounted on a motorcycle frame, the motorcycle wheels and frame in broken lines, showing our new design; FIG. 2 is a left side elevation view of the motorcycle body of FIG. 1;

FIG. 3 is a front elevation view of the motorcycle body of FIG. 1;

FIG. 4 is a rear elevation view of the motorcycle body of FIG. 1;

FIG. 5 is a top plan view of the motorcycle body of FIG. 1;

FIG. 6 is a bottom plan view of the motorcycle body of FIG. 1; and,

FIG. 7 is a top, front, right perspective view of the motorcycle body of FIG. 1.

The broken lines showing portions of a motorcycle in FIG. 1, and showing portions of the motorcycle body in other figures, are included for the purpose of illustrating unclaimed environment and unclaimed features and form no part of the claimed design.

1 Claim, 6 Drawing Sheets

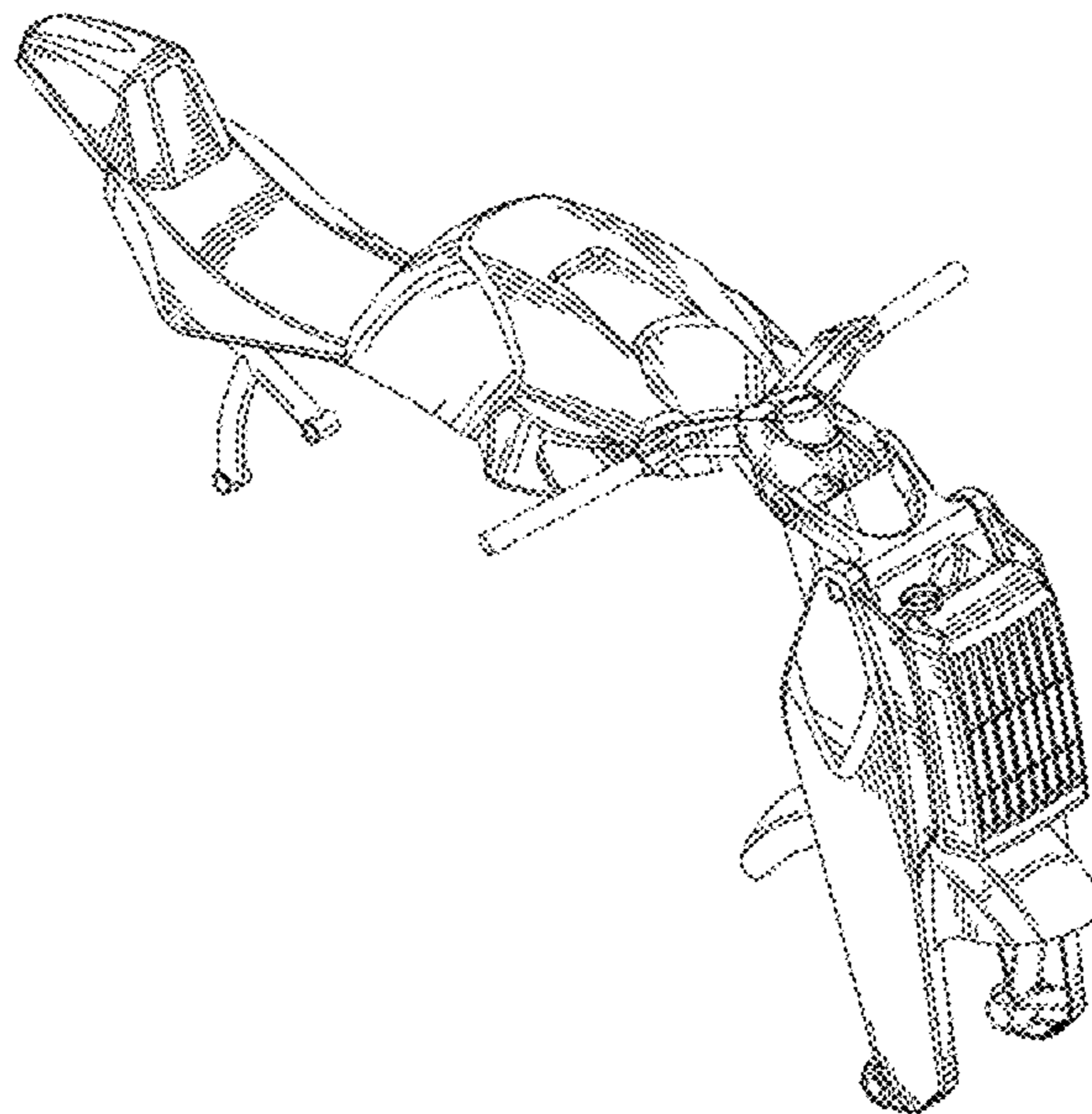

OTHER PUBLICATIONS

TheKneeslider_com_2008_R1_with_Girder_Front_Suspension TheKneeslider.com (2008) The Kneeslider; R1 with Girder Front Suspension—Update; R1 girder 1—off project bike, not in

production; Website [Online] Available Web Site: <http://thekneeslider.com/archives/2008/06/05/r1-with-girder-front-end-update/>; Last Update: Unknown; Accessed on: Apr. 1, 2011.

* cited by examiner

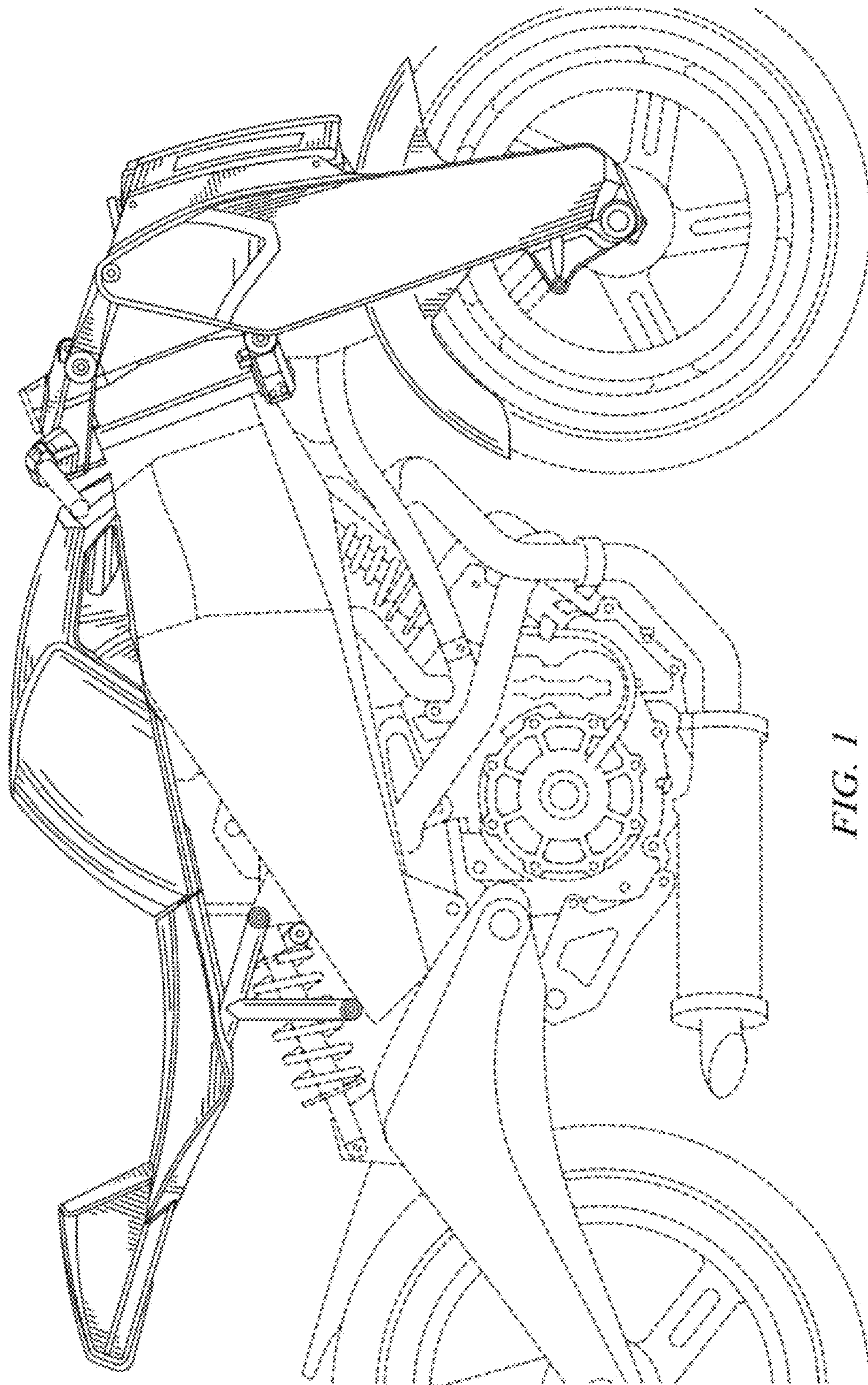

FIG. 1

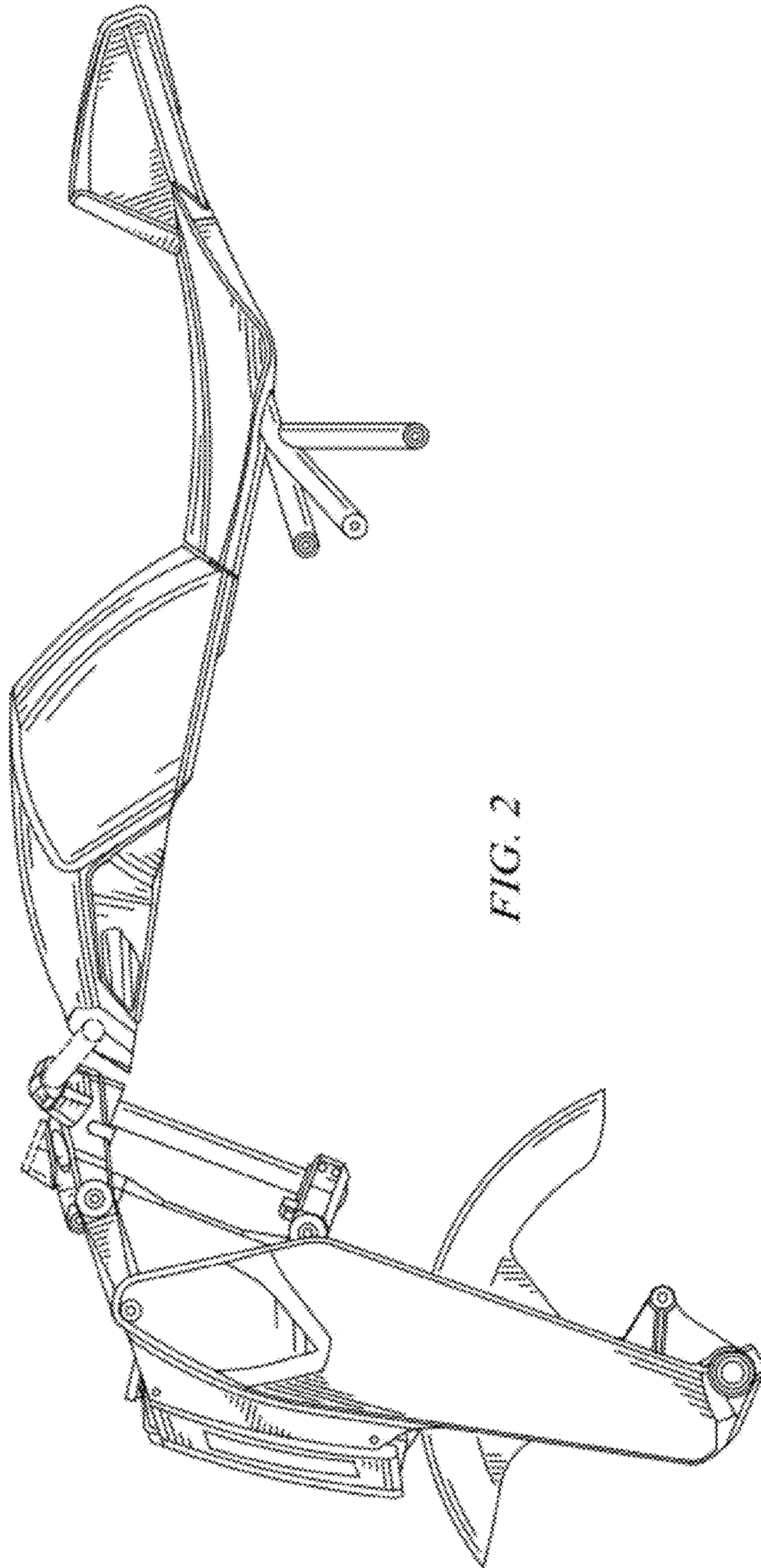

FIG. 2

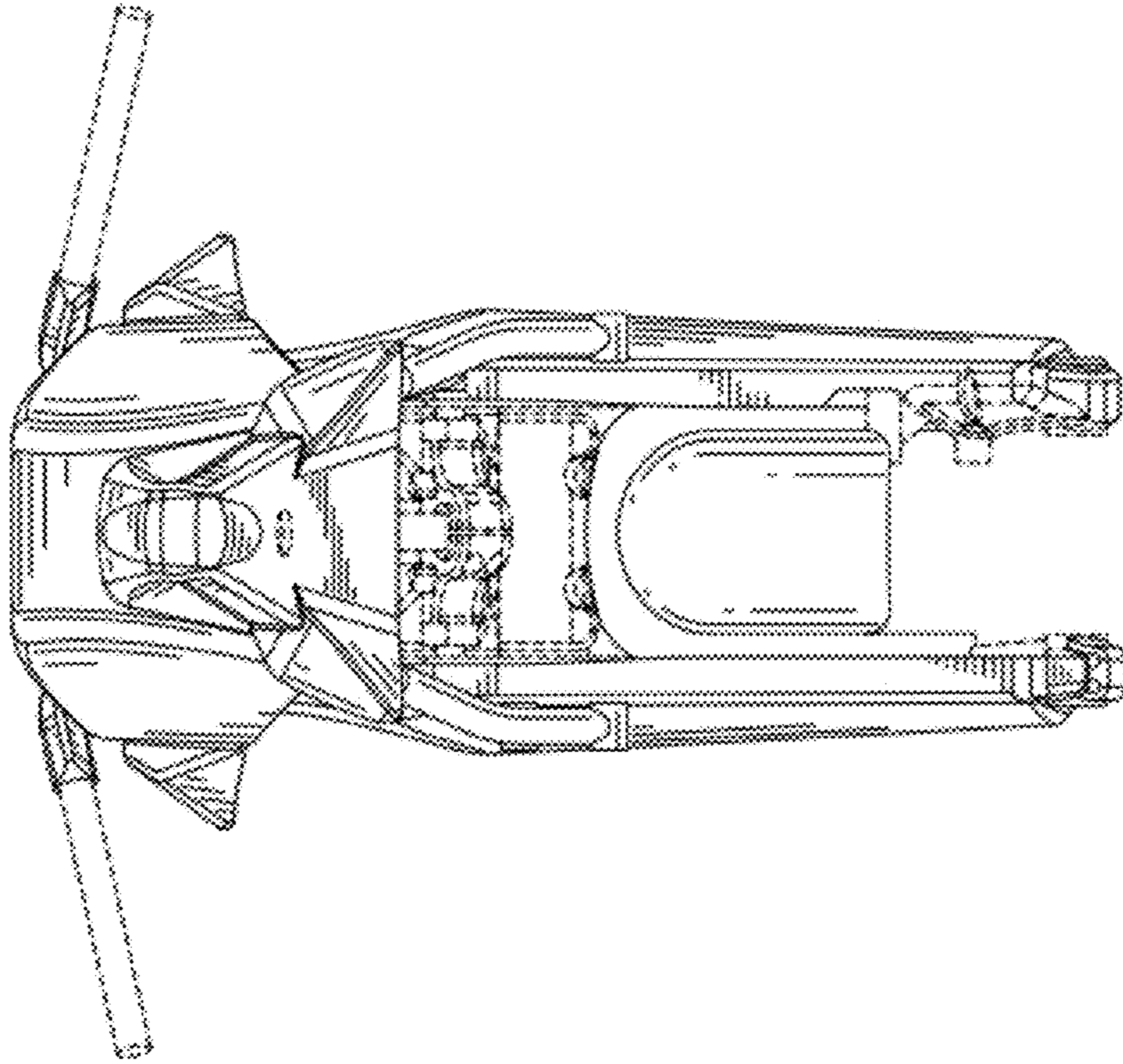

FIG. 4

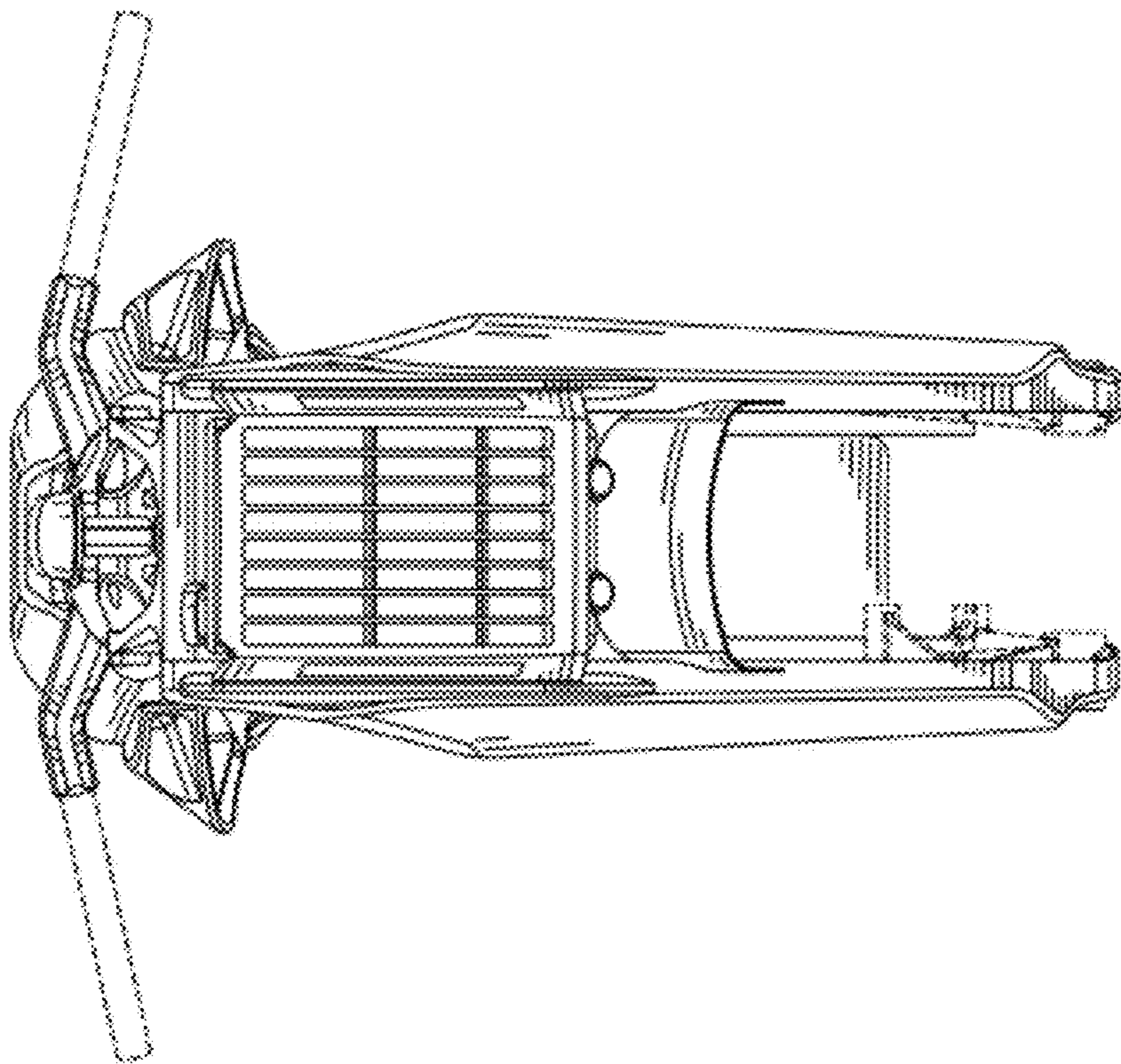

FIG. 3

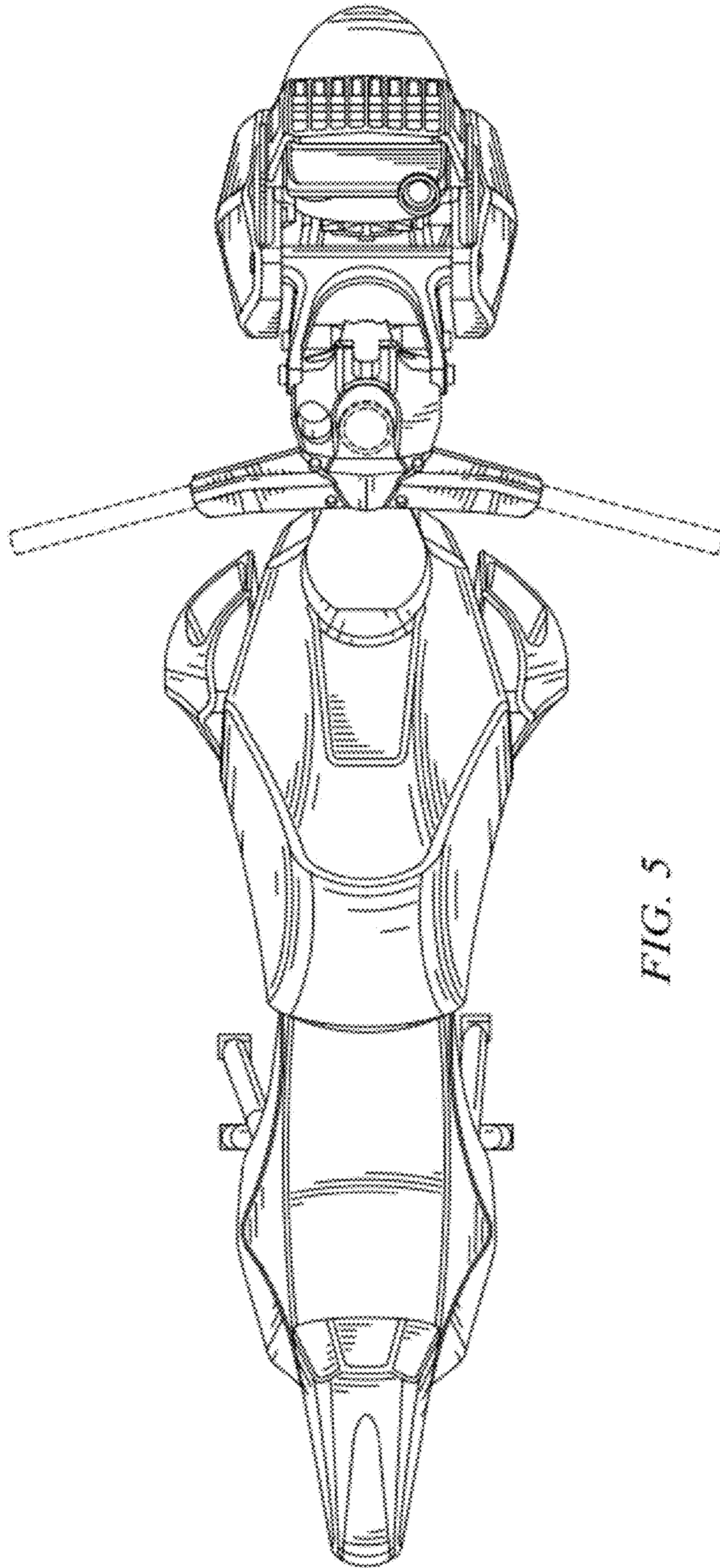

FIG. 5

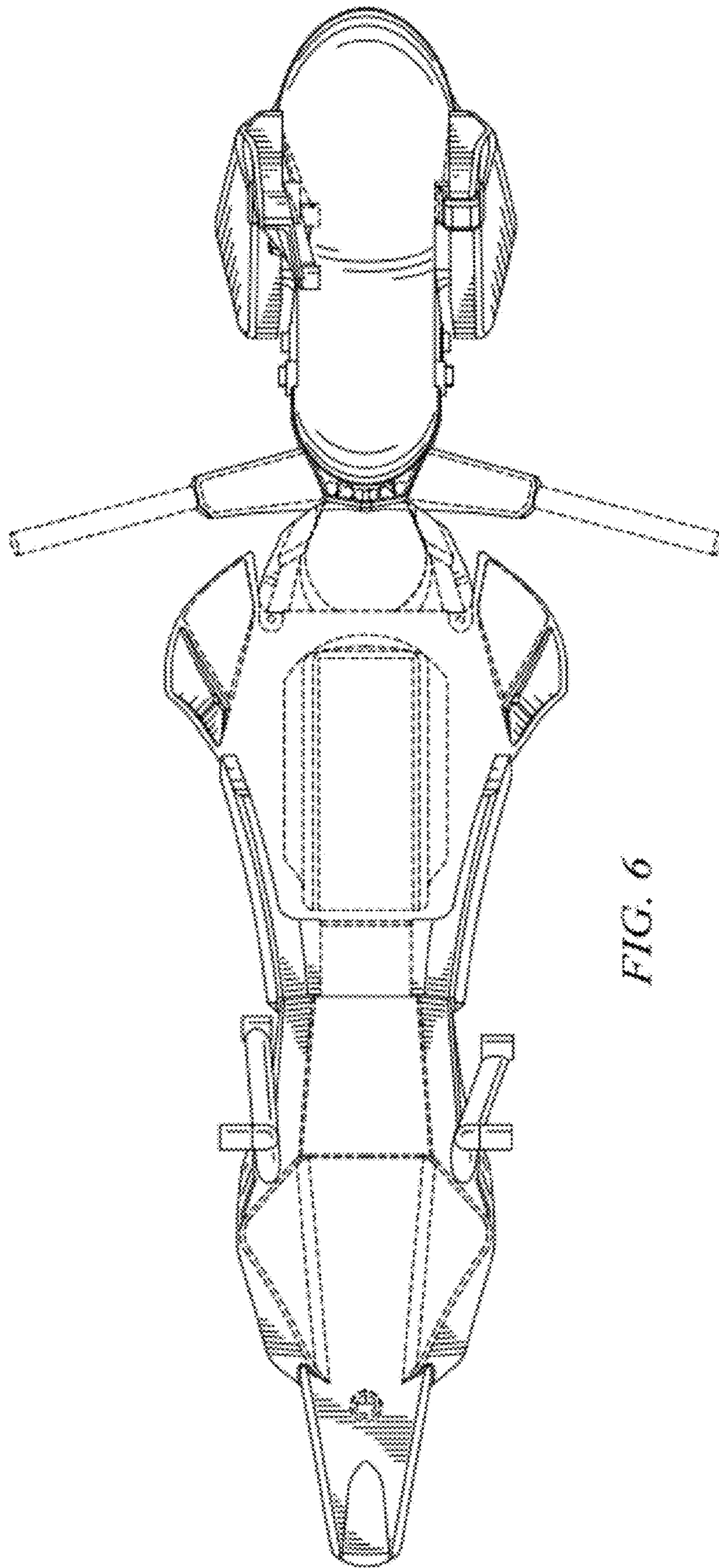

FIG. 6

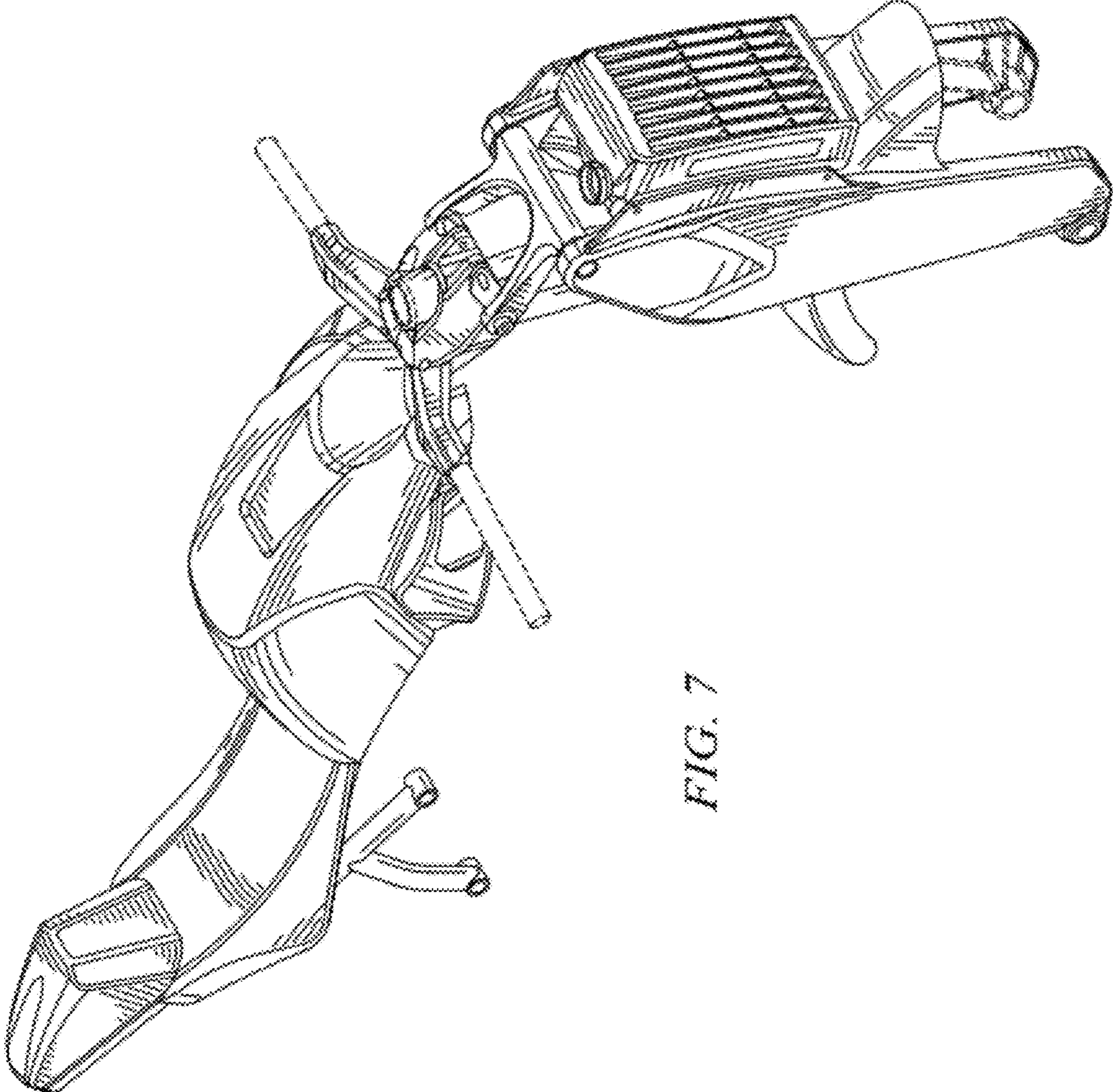

FIG. 7