



US00D659669S

(12) **United States Design Patent**  
**Sarif et al.**

(10) **Patent No.:** **US D659,669 S**

(45) **Date of Patent:** **\*\* May 15, 2012**

(54) **AUDIO PLAYER**

(75) Inventors: **Indra Sarif**, Singapore (SG); **Takuya Motoishi**, Tokyo (JP)

(73) Assignee: **Sony Corporation**, Tokyo (JP)

(\*\*) Term: **14 Years**

(21) Appl. No.: **29/347,418**

(22) Filed: **Dec. 28, 2009**

(51) **LOC (9) Cl.** ..... **14-03**

(52) **U.S. Cl.** ..... **D14/188; D14/257; D14/265**

(58) **Field of Classification Search** ..... D9/137,  
D9/155, 160-171, 188, 192-198, 203.1-203.8,  
D9/204, 217, 257, 258, 265, 496; 455/344-351;  
369/6-12

See application file for complete search history.

(56) **References Cited**

**U.S. PATENT DOCUMENTS**

D305,703 S *	1/1990	Wang	.....	D6/314
D354,285 S	1/1995	Lee		
D416,557 S	11/1999	Matsuoka		
D423,006 S	4/2000	Matsuoka		
D424,058 S	5/2000	Shudo		
D439,227 S *	3/2001	Okada et al.	.....	D14/499
D452,852 S	1/2002	Hyogo et al.		
D455,415 S	4/2002	Suzuki		
D467,569 S	12/2002	Kobayashi		
D468,276 S *	1/2003	Chang	.....	D14/126
D468,718 S	1/2003	Cuvelier		
D491,902 S *	6/2004	Chen	.....	D14/126
D496,944 S *	10/2004	Huang	.....	D14/203.4
D505,410 S	5/2005	Sugiyama		
D512,045 S	11/2005	Motoishi		
D516,539 S	3/2006	Masui		
D521,974 S	5/2006	Katsumata		

D547,298 S	7/2007	Hibino		
D547,300 S	7/2007	Hibino		
D547,308 S *	7/2007	Aihara	.....	D14/168
D550,646 S	9/2007	Kaneko		
D556,162 S	11/2007	Tragatschnig		
D556,733 S	12/2007	Law		
D565,559 S *	4/2008	Aihara	.....	D14/258
D567,255 S *	4/2008	Miyawaki	.....	D14/496
D571,347 S	6/2008	Masui		
D571,756 S	6/2008	Sugiyama et al.		
D576,177 S *	9/2008	Asanuma et al.	.....	D14/496
D582,909 S *	12/2008	Yamamoto	.....	D14/258
D597,065 S	7/2009	Hong		
D608,774 S *	1/2010	Iwamoto et al.	.....	D14/258
D611,928 S *	3/2010	Hansen et al.	.....	D14/188

\* cited by examiner

*Primary Examiner* — Stella Reid

*Assistant Examiner* — Keli L Hill

(74) *Attorney, Agent, or Firm* — Rader, Fishman & Grauer PLLC

(57) **CLAIM**

The ornamental design for an audio player, as shown and described.

**DESCRIPTION**

FIG. 1 is a perspective view of an audio player showing our new design;  
FIG. 2 is a front elevational view thereof;  
FIG. 3 is a left side elevational view thereof;  
FIG. 4 is a right side elevational view thereof; and,  
FIG. 5 is a top plan view thereof.  
The dot-dash broken lines represent the bounds of the claimed design while all other broken lines are included for the purpose of illustrating the unclaimed portions of the article; the broken lines form no part of the claimed design.

**1 Claim, 5 Drawing Sheets**

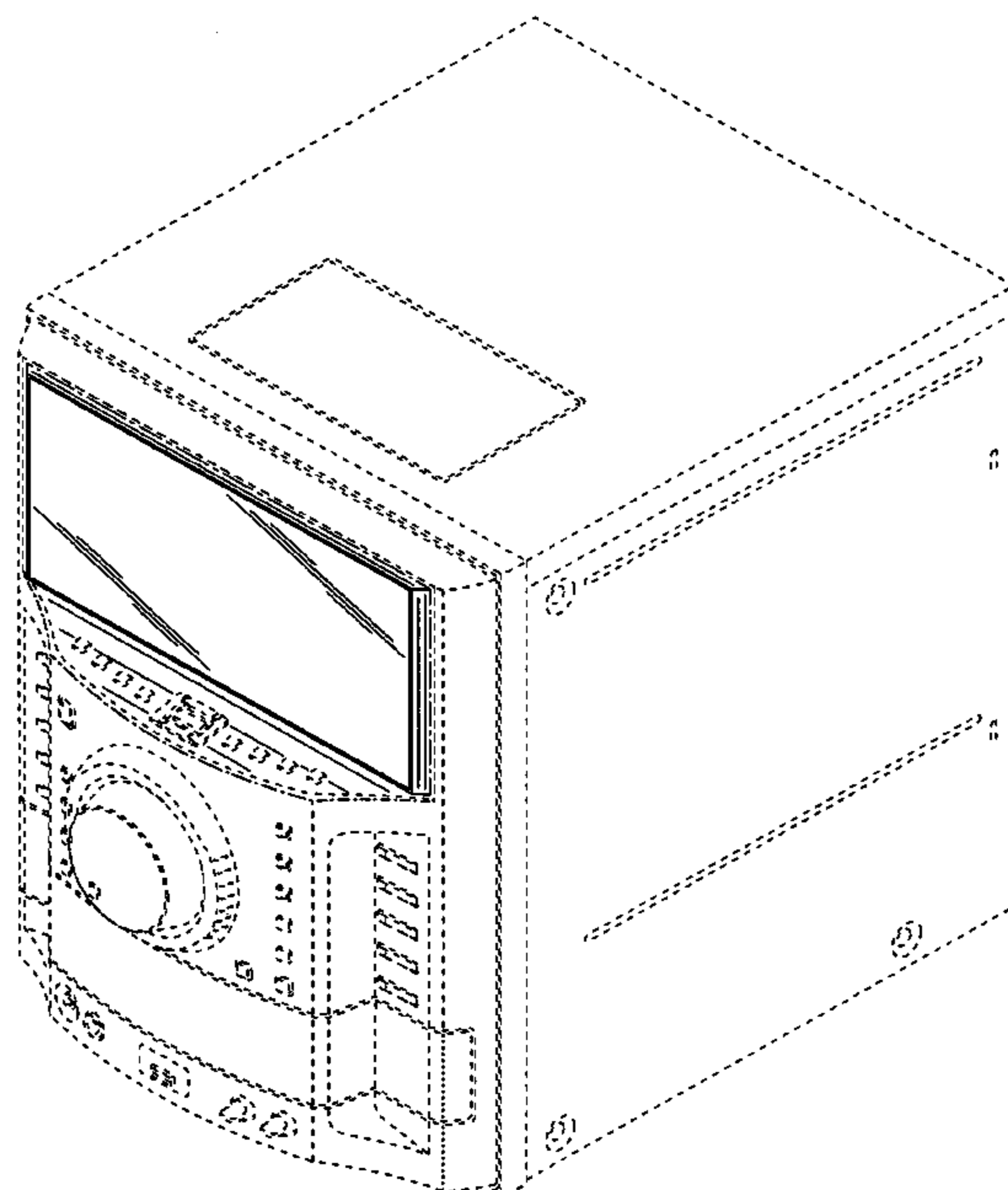

FIG.1

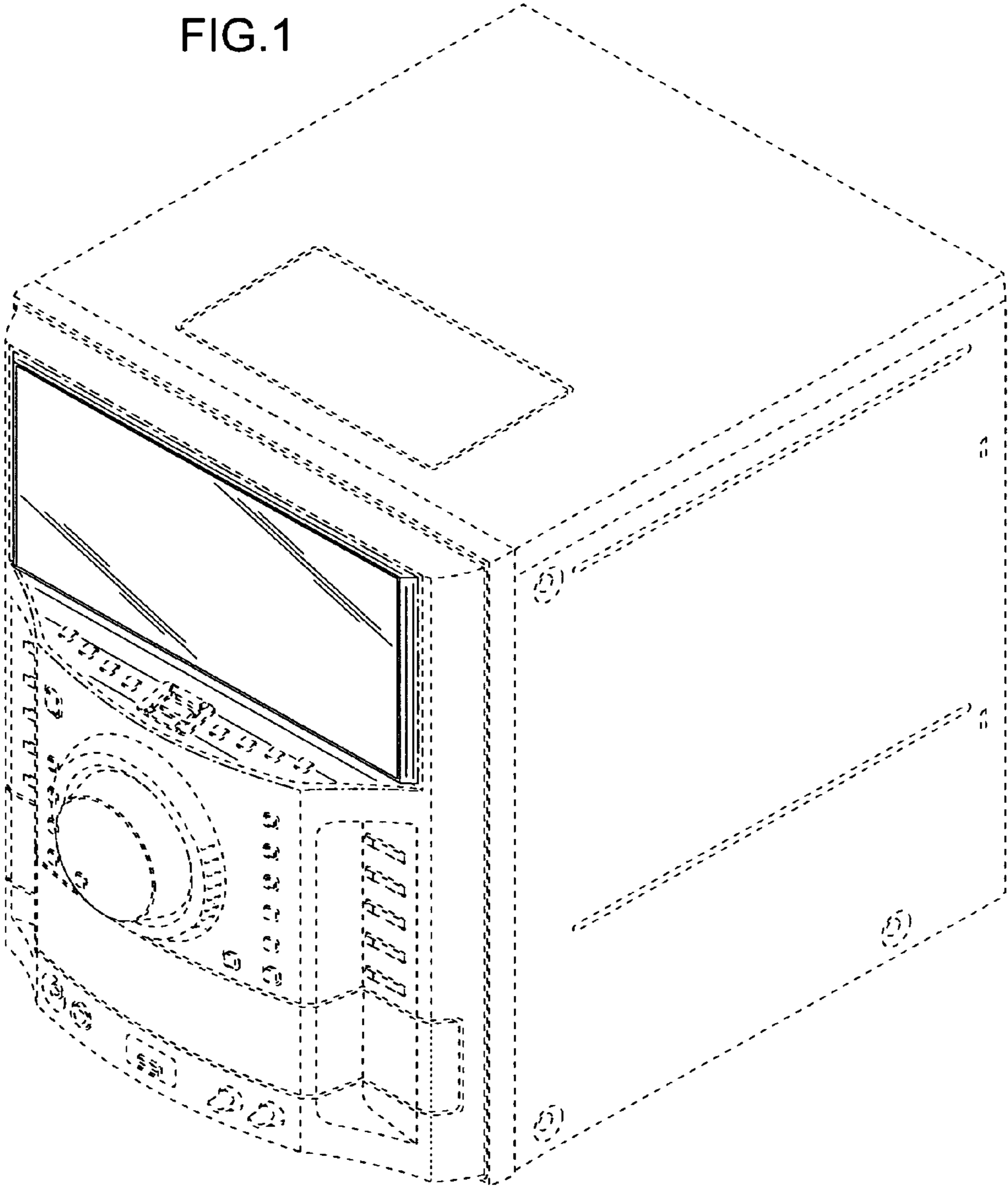

FIG.2

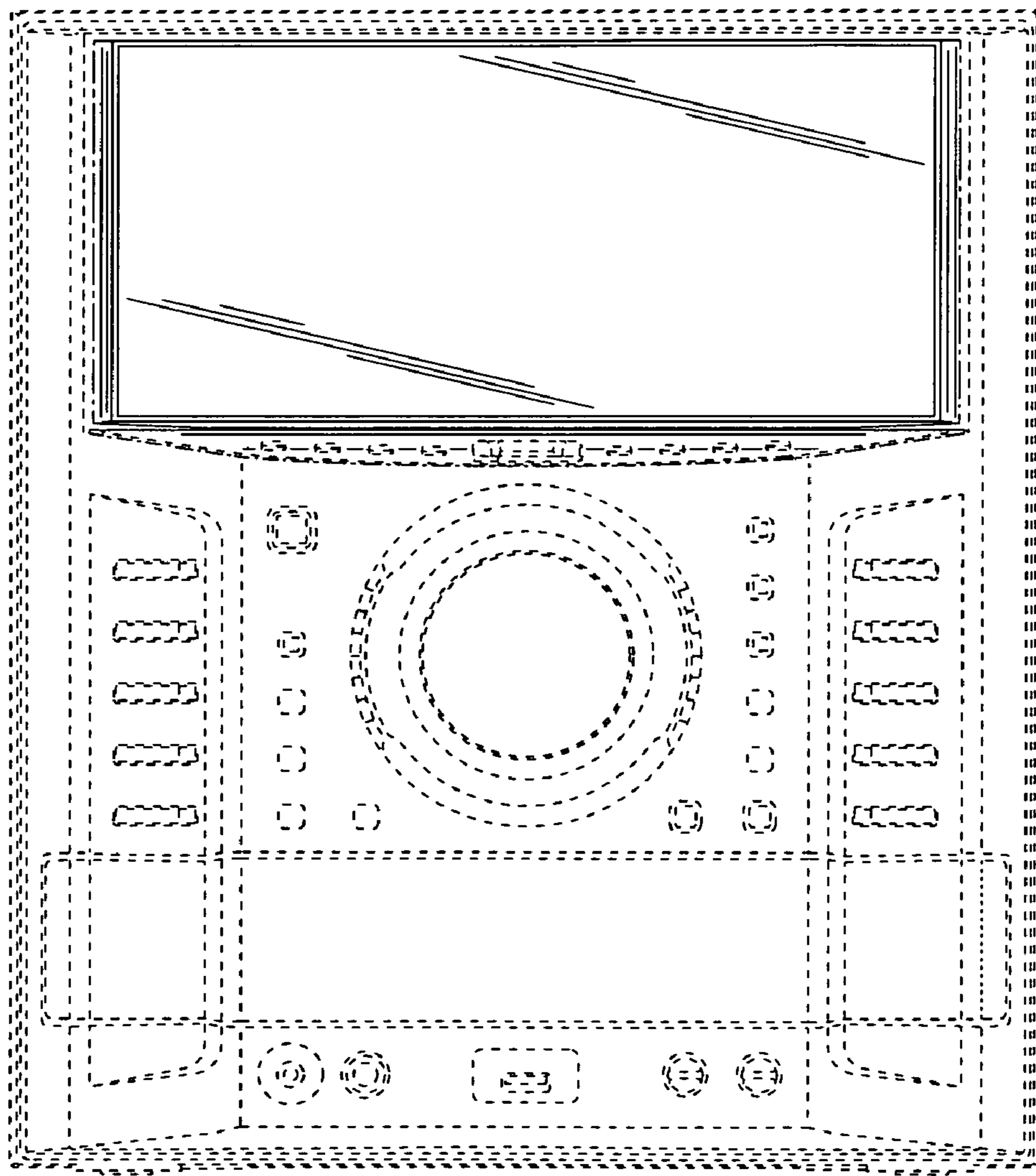

FIG.3

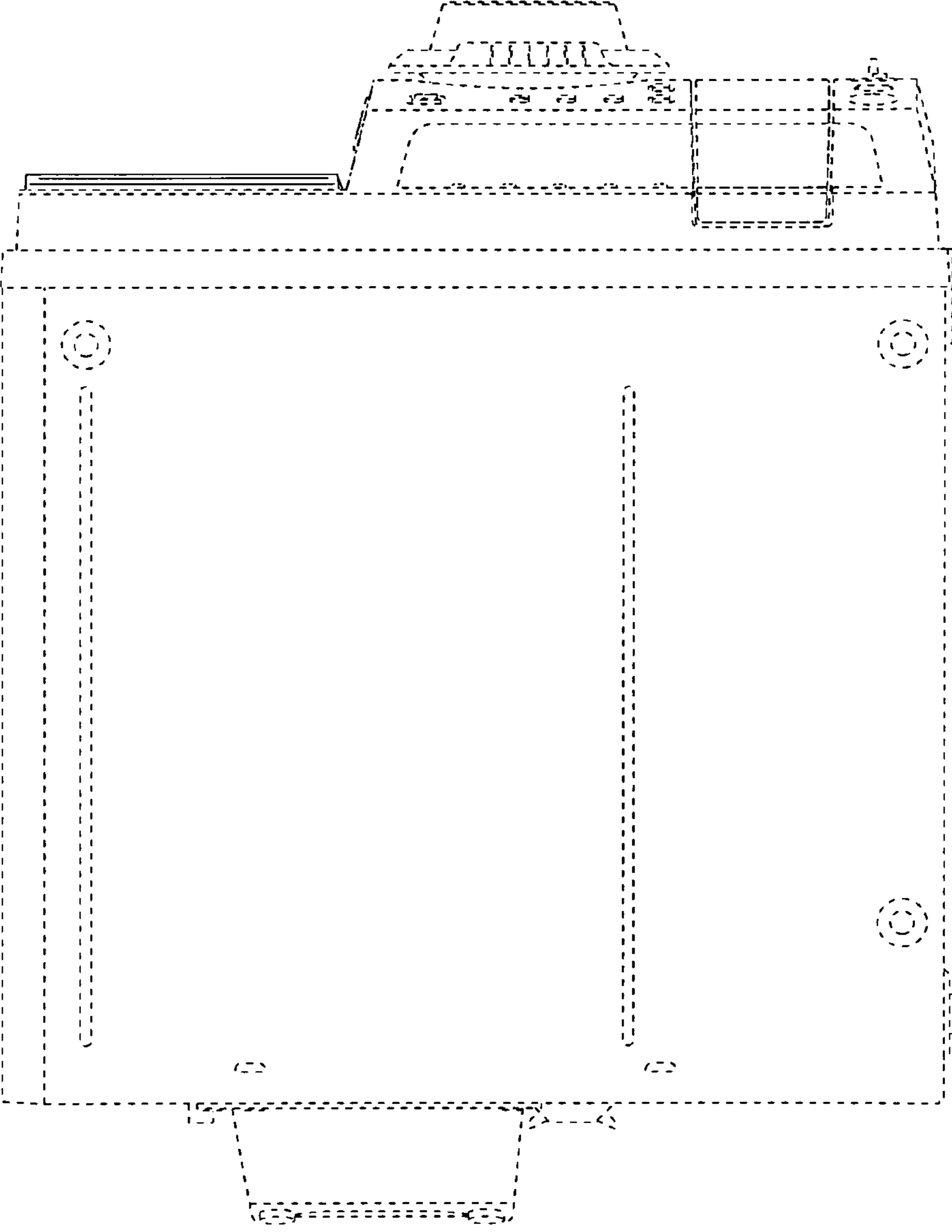

FIG.4

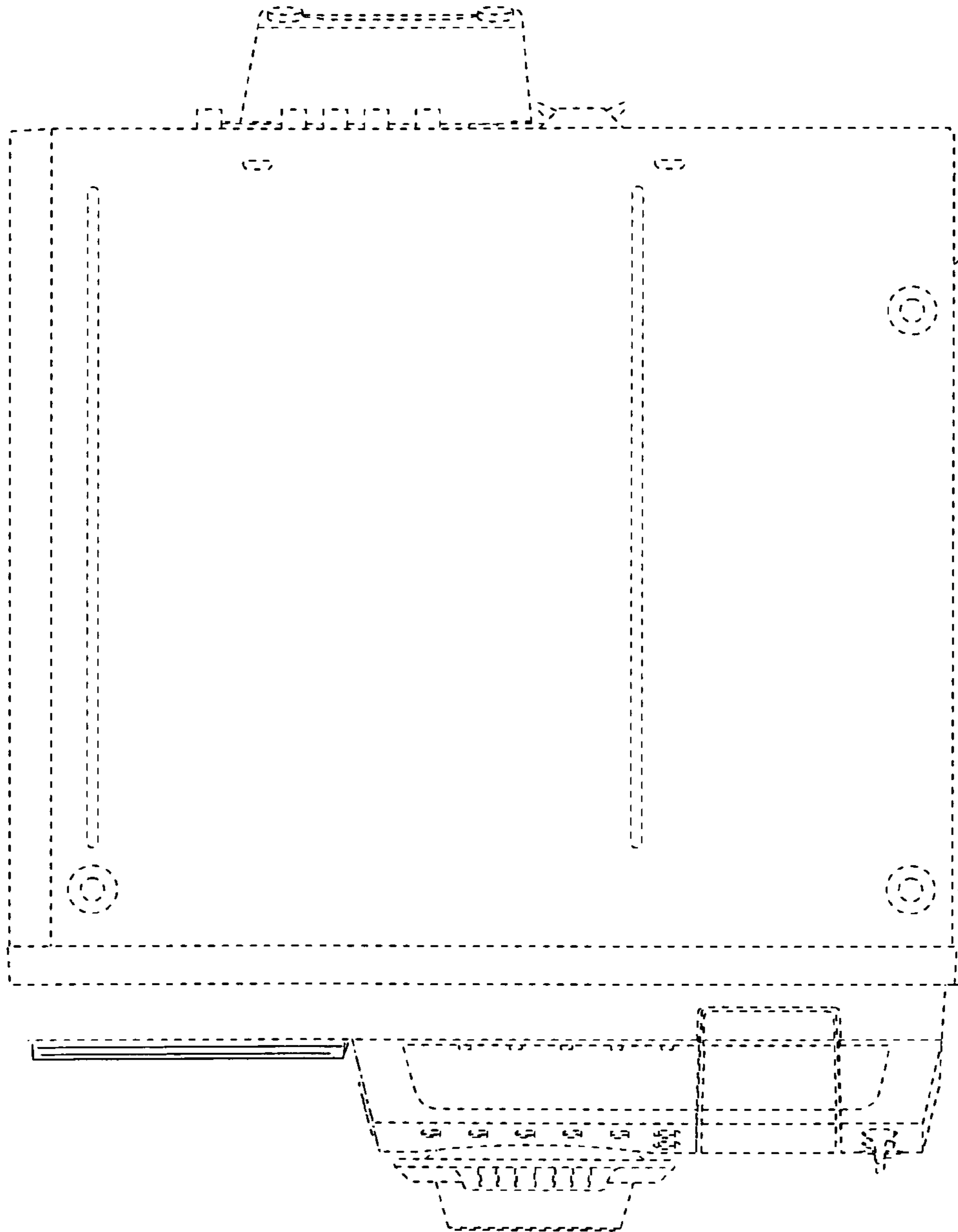

FIG.5

