



US00D659425S

(12) **United States Design Patent**  
**Genova**

(10) **Patent No.:** **US D659,425 S**

(45) **Date of Patent:** **\*\* May 15, 2012**

(54) **STORE DISPLAY FOR BEAUTY CARE PRODUCT**

U.S. Appl. No. 29/381,385, filed Dec. 17, 2010, Miller.  
U.S. Appl. No. 29/381,387, filed Dec. 17, 2010, Thorne.

(75) Inventor: **Brandon Wayne Genova**, Denver, CO (US)

\* cited by examiner

(73) Assignee: **The Procter & Gamble Company**, Cincinnati, OH (US)

*Primary Examiner* — Philip S Hyder  
*Assistant Examiner* — Sydney Buffalow  
(74) *Attorney, Agent, or Firm* — Carl J. Roof

(\*\*) Term: **14 Years**

(57) **CLAIM**

(21) Appl. No.: **29/387,793**

The ornamental design for a store display for a beauty care product, as shown and described.

(22) Filed: **Mar. 18, 2011**

(51) **LOC (9) Cl.** ..... **06-04**

(52) **U.S. Cl.** ..... **D6/396**

(58) **Field of Classification Search** ..... D6/396,  
D6/397, 450, 449, 472; D7/301; D15/81,  
D15/515; D20/17, 22, 37; D9/550, 329;  
211/13.1, 14, 85.2, 85.4, 85.26

See application file for complete search history.

**DESCRIPTION**

FIG. 1 is a perspective top view of a store display for a beauty care product, embodying our new design;  
FIG. 2 is a front view of a store display for a beauty care product of FIG. 1;  
FIG. 3 is a left view of a store display for a beauty care product of FIG. 1;  
FIG. 4 is a right side view of a store display for a beauty care product of FIG. 1;  
FIG. 5 is a top view of a store display for a beauty care product of FIG. 1;  
FIG. 6 is a bottom view of a store display for a beauty care product of FIG. 1; and,  
FIG. 7 is a back view of a store display for a beauty care product of FIG. 1.  
The broken lines shown in the drawings are for illustrative purposes only and form no part of the claimed design.

(56) **References Cited**

U.S. PATENT DOCUMENTS

D111,736 S *	10/1938	De Sabato	.....	D6/450
D318,594 S *	7/1991	Shaw	.....	D7/301
D372,814 S *	8/1996	Hartmann	.....	D6/450
D373,690 S *	9/1996	Hartmann	.....	D6/450
D376,157 S *	12/1996	Branz et al.	.....	D15/81
D389,672 S *	1/1998	Antao et al.	.....	D6/472
D420,367 S *	2/2000	Trulaske, Sr.	.....	D15/81

OTHER PUBLICATIONS

U.S. Appl. No. 29/354,847, filed Jan. 29, 2010, Dombrowski.

**1 Claim, 5 Drawing Sheets**

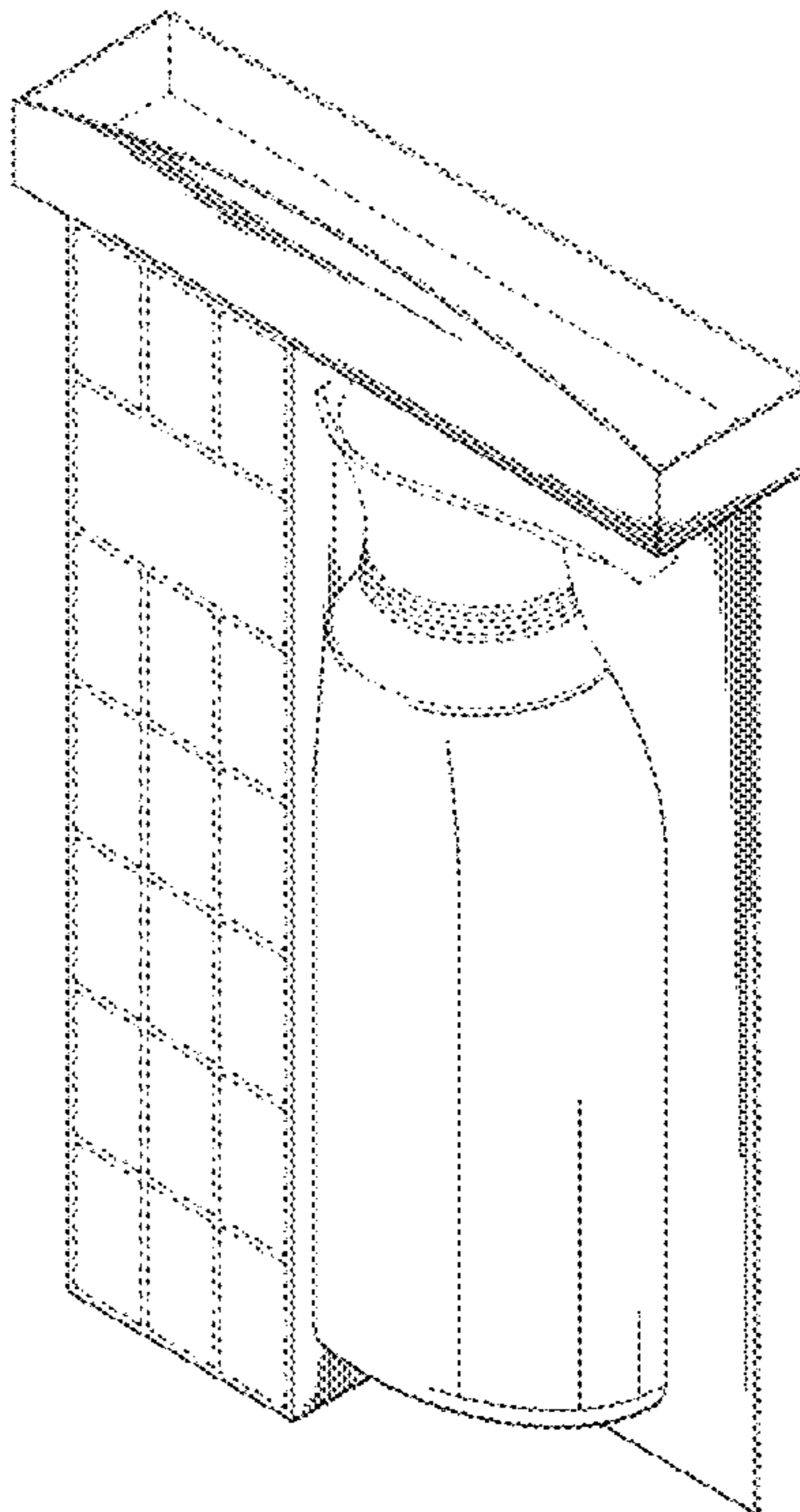

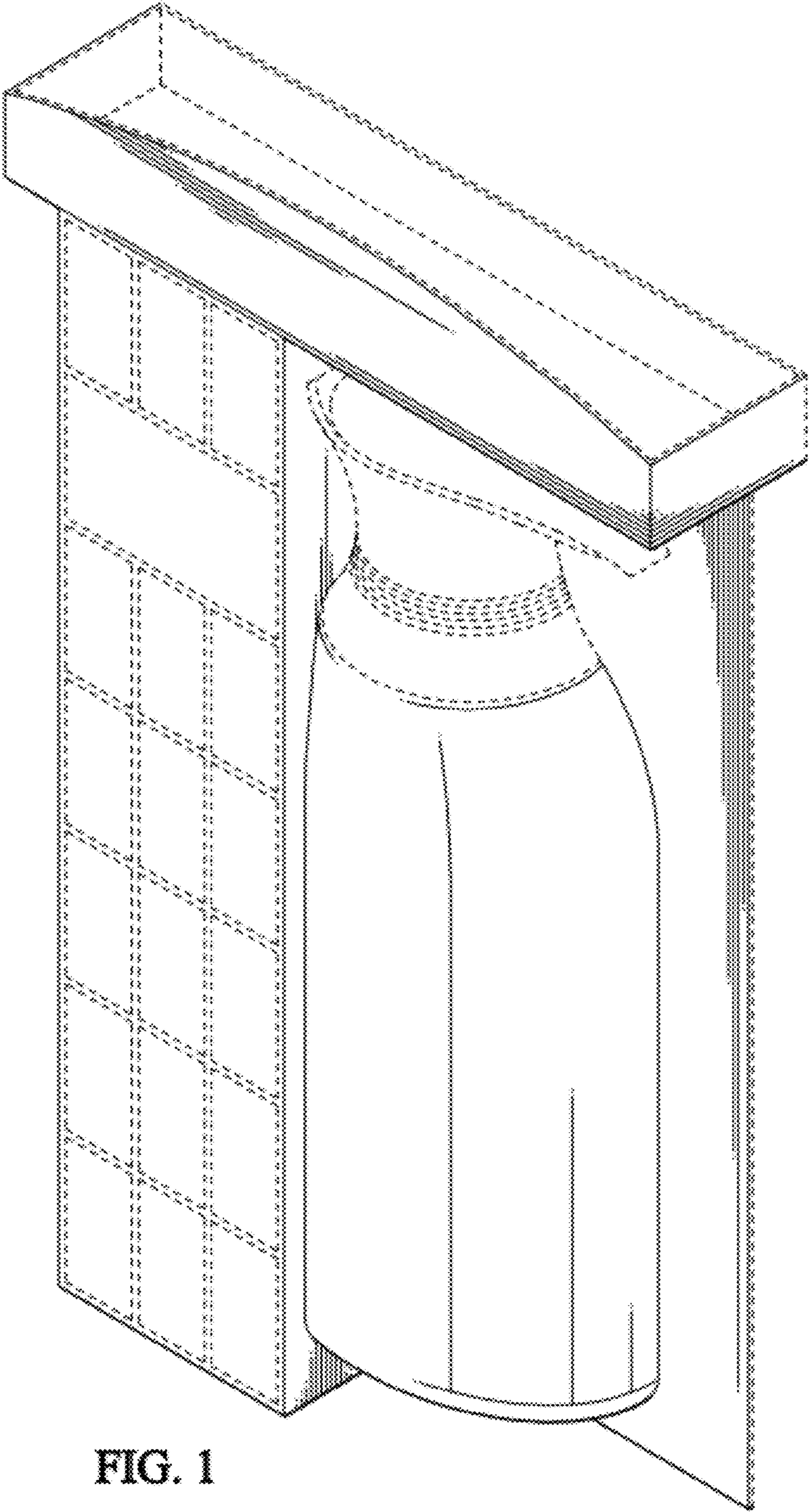

FIG. 1



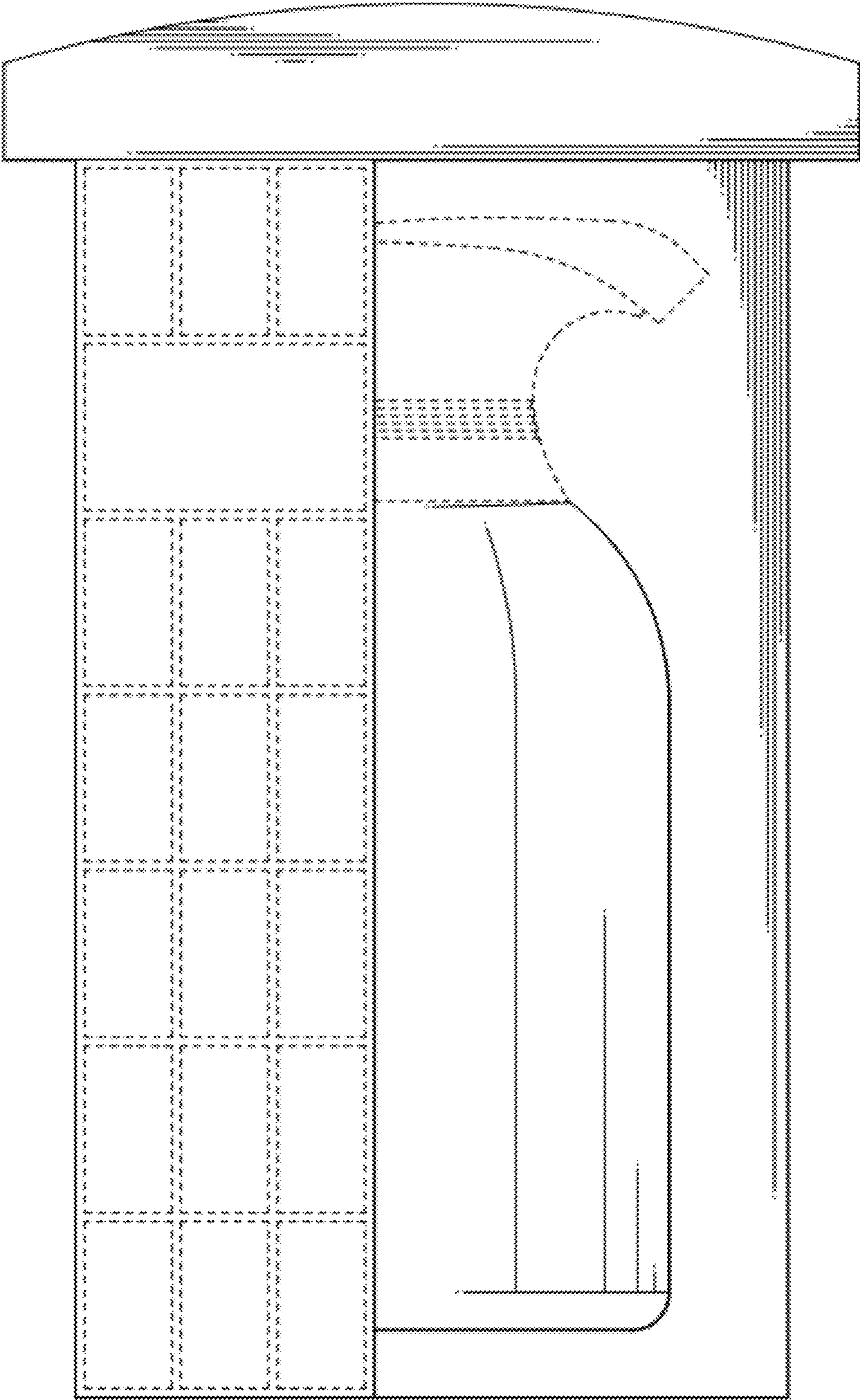

FIG. 2

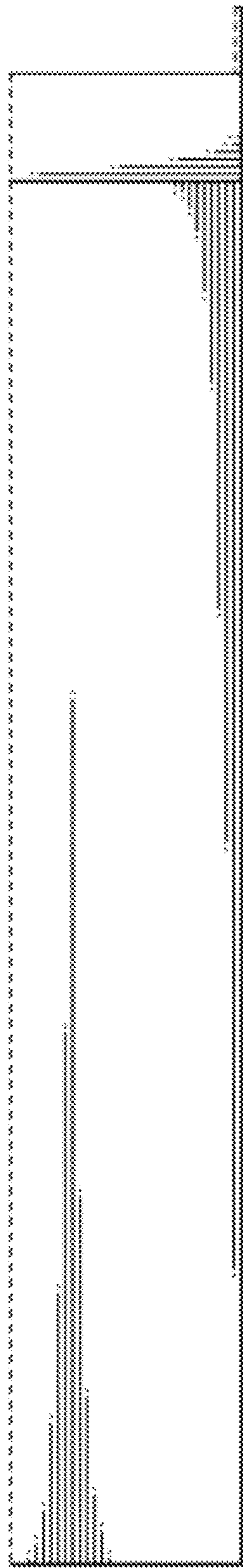

FIG. 3

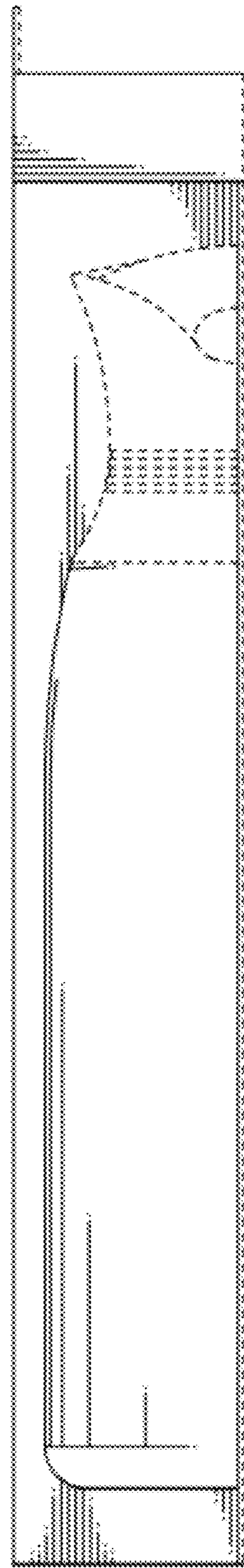

FIG. 4



FIG. 5

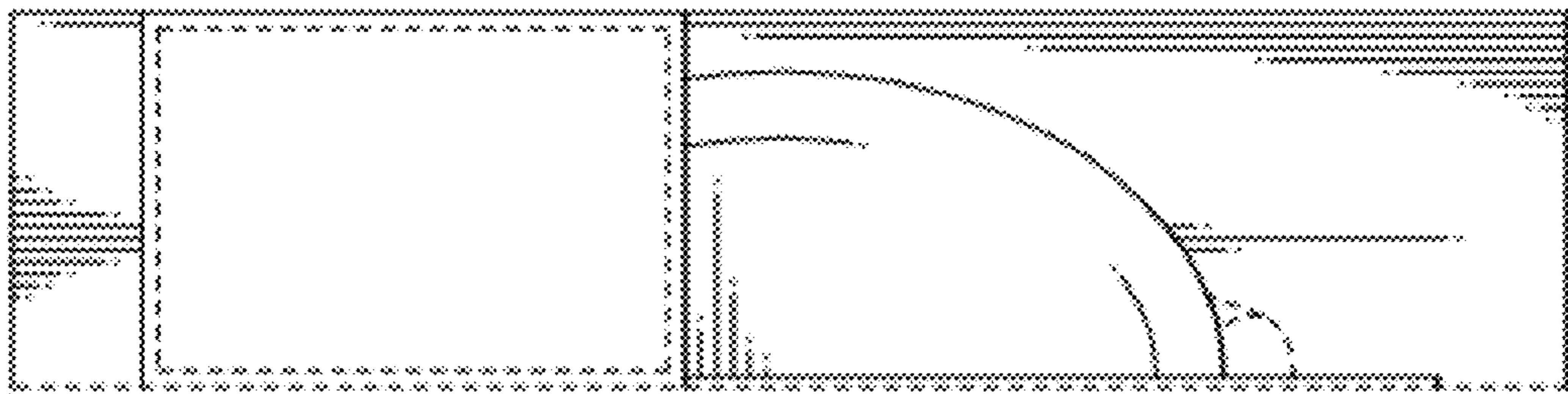

FIG. 6

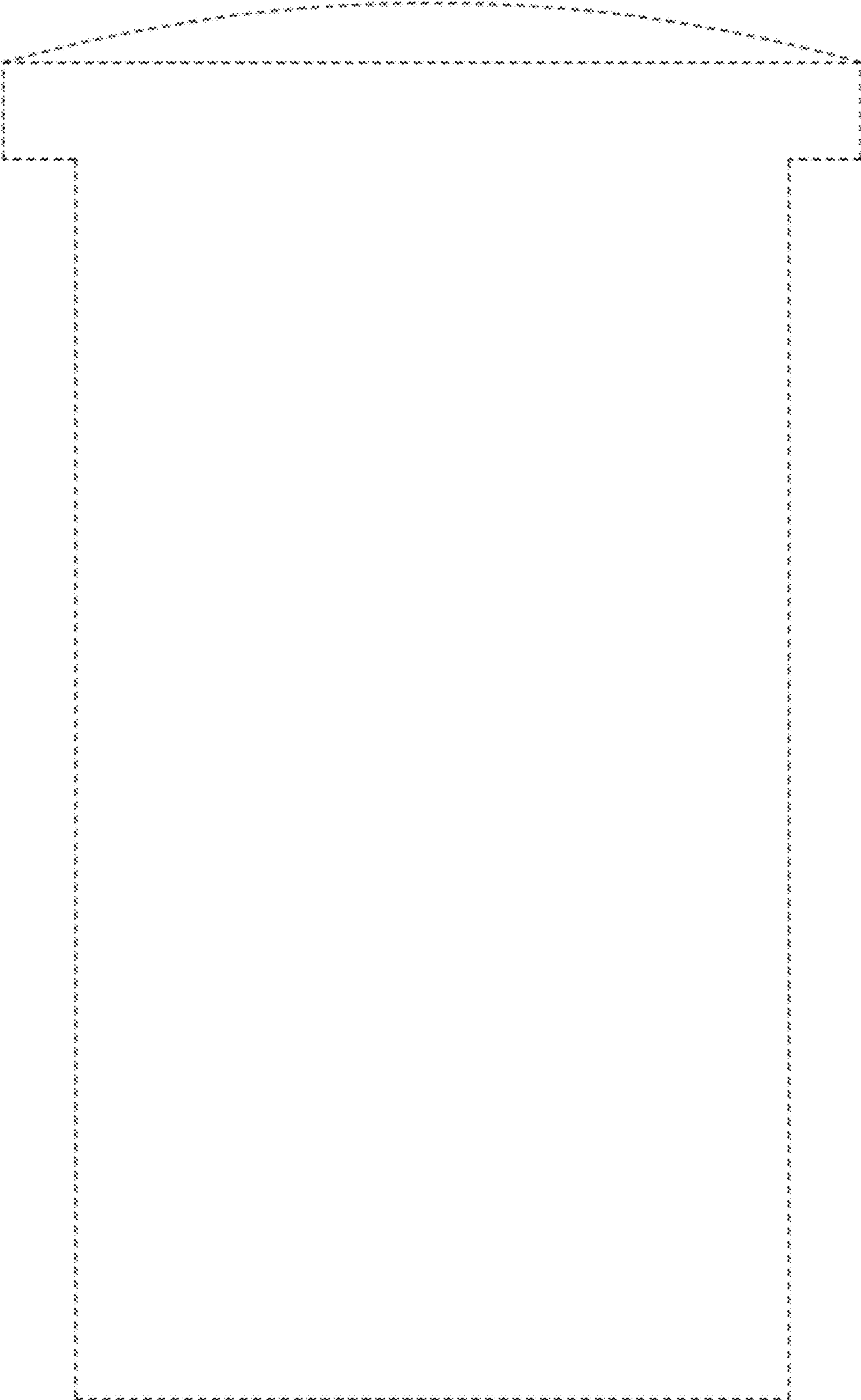

FIG. 7