



US00D658795S

(12) **United States Design Patent**  
**Szymanski**

(10) **Patent No.:** **US D658,795 S**

(45) **Date of Patent:** **\*\* May 1, 2012**

(54) **FLASHLIGHT**

(75) **Inventor:** **Aaron Szymanski**, Thomaston, CT (US)

(73) **Assignee:** **Idea Village Products, Inc.**, Fairfield, NJ (US)

(\*\*) **Term:** **14 Years**

(21) **Appl. No.:** **29/374,588**

(22) **Filed:** **Sep. 6, 2011**

(51) **LOC (9) Cl.** ..... **26-02**

(52) **U.S. Cl.** ..... **D26/39**

(58) **Field of Classification Search** ..... D26/37,  
D26/38, 39, 46, 49, 51; 362/103–106, 157,  
362/158, 194–196, 200–208, 253  
See application file for complete search history.

(56) **References Cited**

**U.S. PATENT DOCUMENTS**

D431,308 S	*	9/2000	Lynch et al.	.....	D26/37
D431,355 S	*	10/2000	Boyd, Jr.	.....	D3/209
D433,170 S	*	10/2000	Chan	.....	D26/38
D434,162 S	*	11/2000	Lau	.....	D26/37
D439,352 S	*	3/2001	Lai	.....	D26/37
D448,505 S	*	9/2001	Dalton et al.	.....	D26/37
D455,854 S	*	4/2002	Smith	.....	D26/37
D463,052 S	*	9/2002	Shiu	.....	D26/38
D465,591 S	*	11/2002	Krieger et al.	.....	D26/38
D475,195 S	*	6/2003	Christianson	.....	D3/209
D495,073 S	*	8/2004	Kumthampinij et al.	.....	D26/37
D497,019 S	*	10/2004	Lee	.....	D26/37

D498,553 S	*	11/2004	Lee	.....	D26/37
D498,864 S	*	11/2004	Lee	.....	D26/37
D545,467 S	*	6/2007	Chun	.....	D26/37
D546,989 S	*	7/2007	Chun	.....	D26/37
D546,990 S	*	7/2007	Wang et al.	.....	D26/37
D553,274 S	*	10/2007	Hill et al.	.....	D26/37
D553,275 S	*	10/2007	Campbell et al.	.....	D26/37
D561,366 S	*	2/2008	Wang	.....	D26/37
D574,527 S	*	8/2008	Squires et al.	.....	D26/37
D576,323 S	*	9/2008	Cienfuegos	.....	D26/37

\* cited by examiner

*Primary Examiner* — Ian Simmons

*Assistant Examiner* — Carissa C Fitts

(74) *Attorney, Agent, or Firm* — Dan De LaRosa, Esq.

(57) **CLAIM**

The ornamental design for a flashlight, as shown and described.

**DESCRIPTION**

FIG. 1 is a front perspective view of the flashlight of the present invention showing my new design; FIG. 2 is a front side elevational view thereof; FIG. 3 is a back side elevational view thereof; FIG. 4 is a side elevational view thereof; FIG. 5 is another side elevational view thereof; FIG. 6 is a top plan view thereof; and, FIG. 7 is a bottom plan view thereof. The broken line showing is for environmental purposes only and forms no part of the claimed design.

**1 Claim, 5 Drawing Sheets**

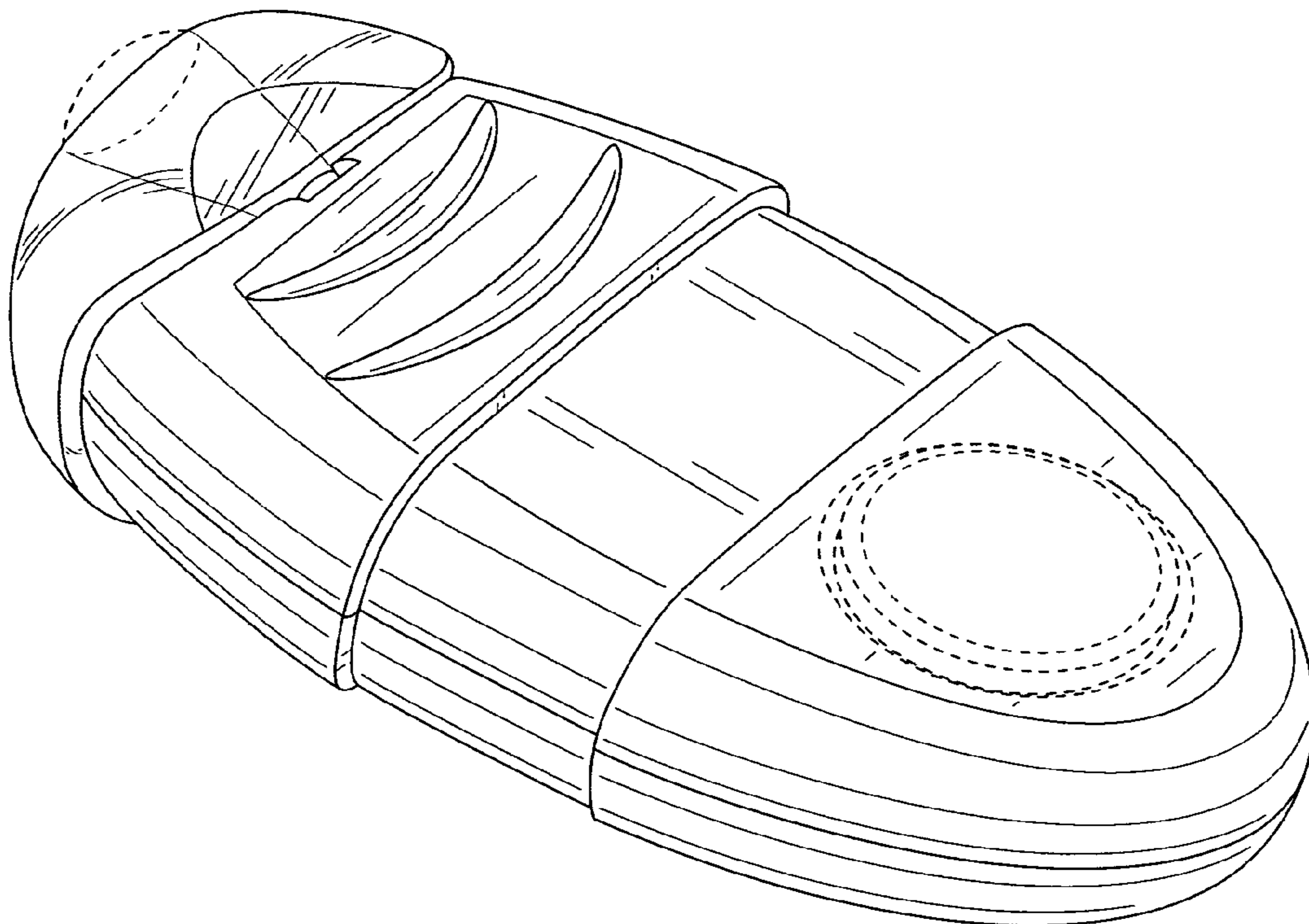

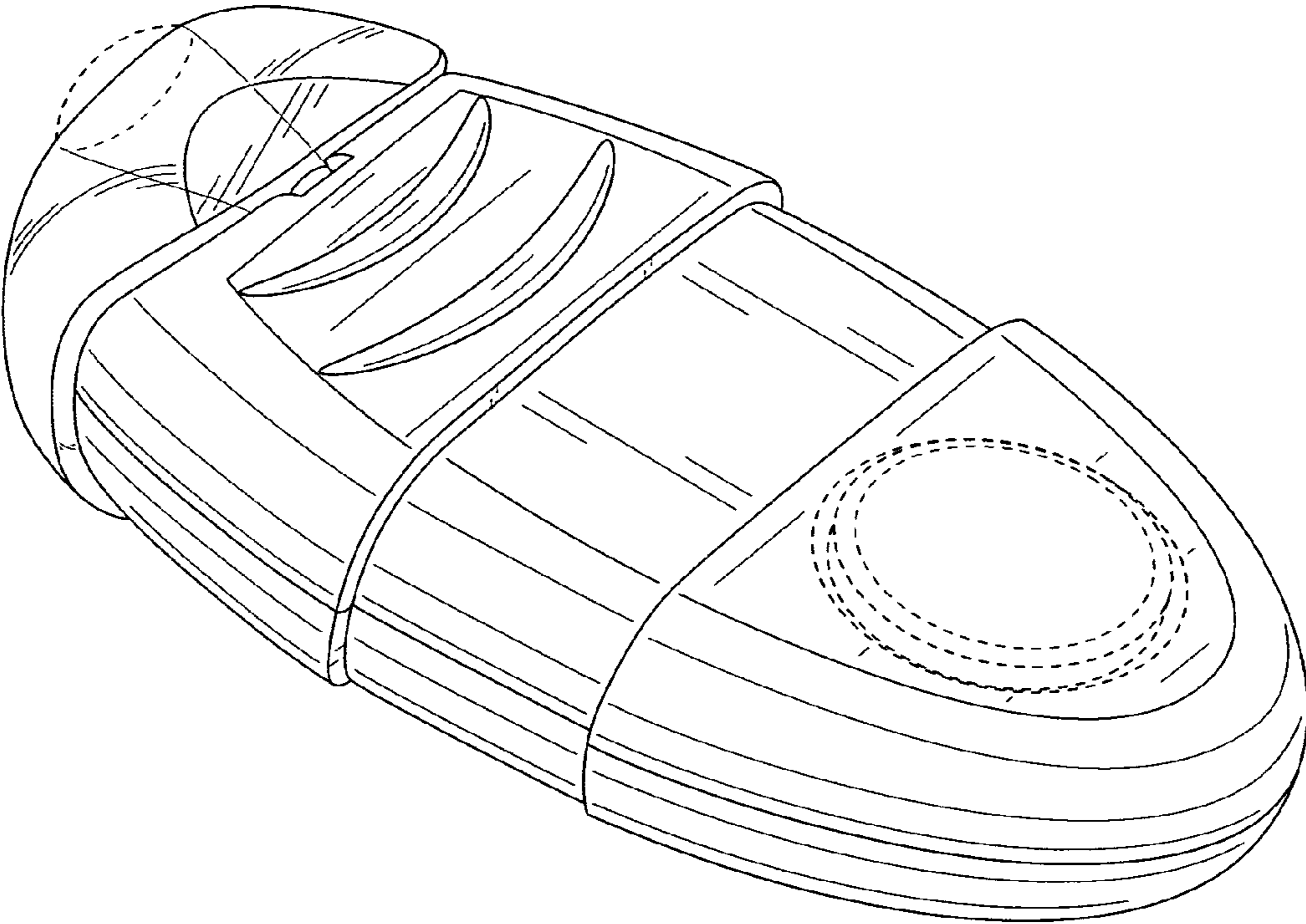

FIG. 1

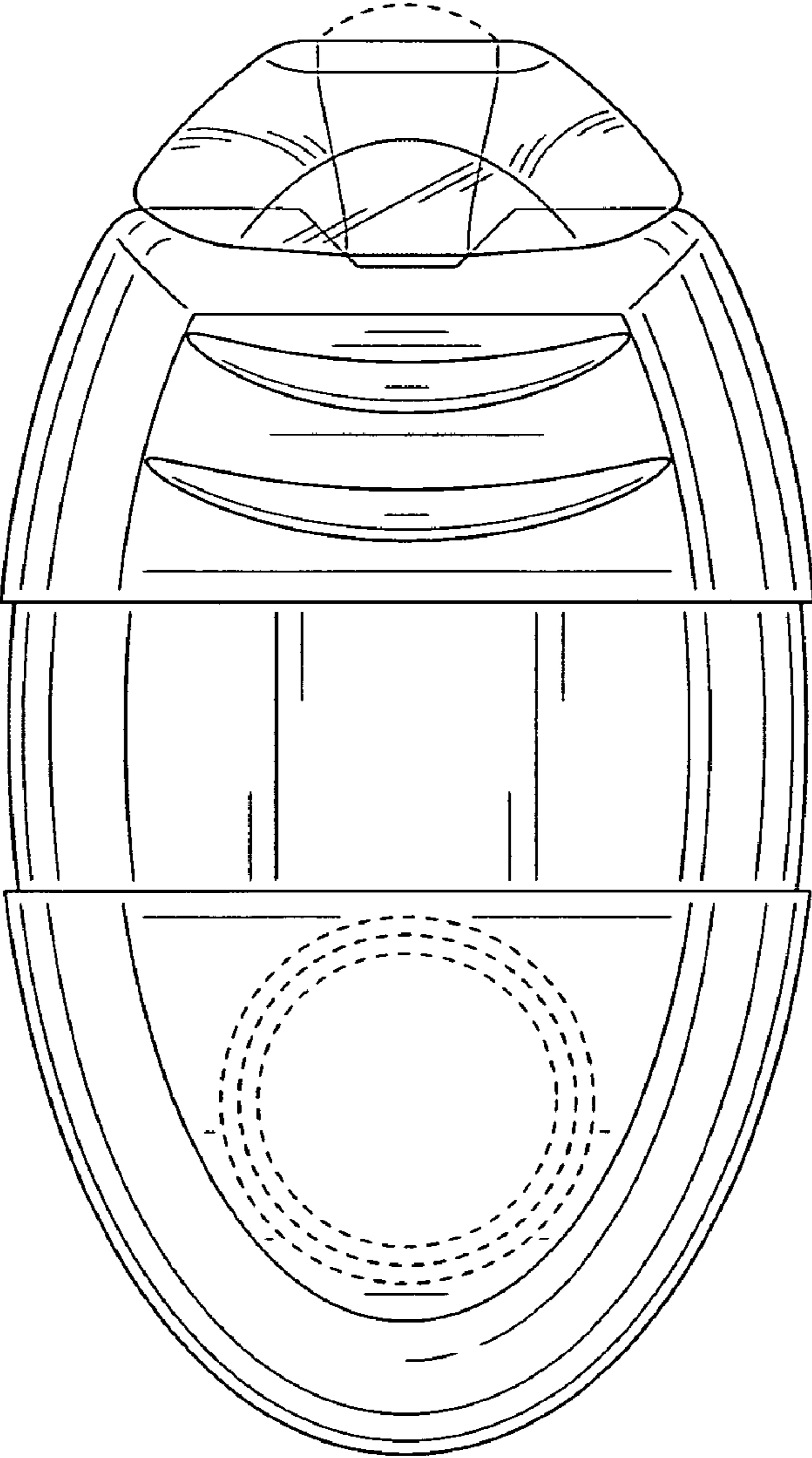

FIG. 2

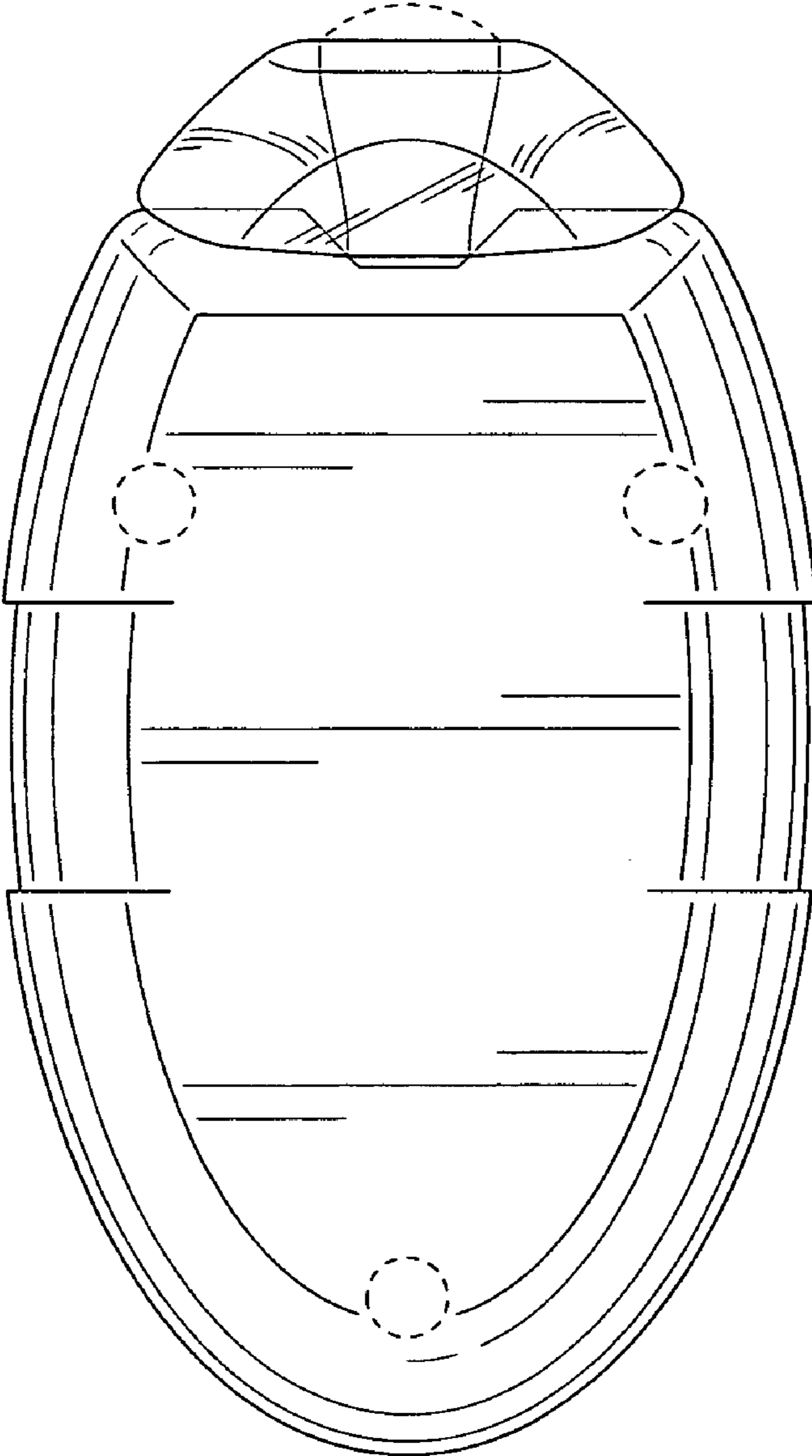

FIG. 3

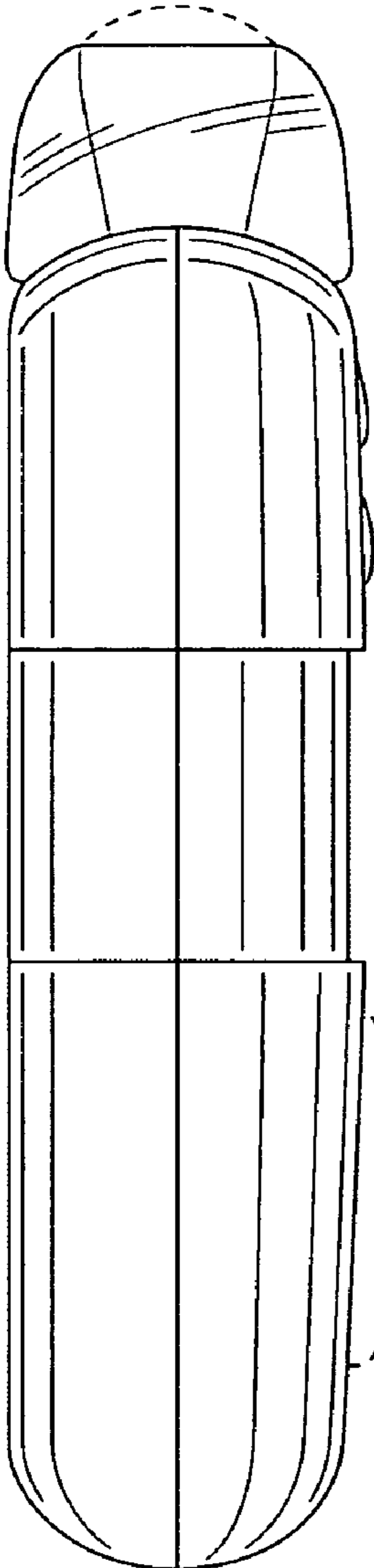

FIG. 4

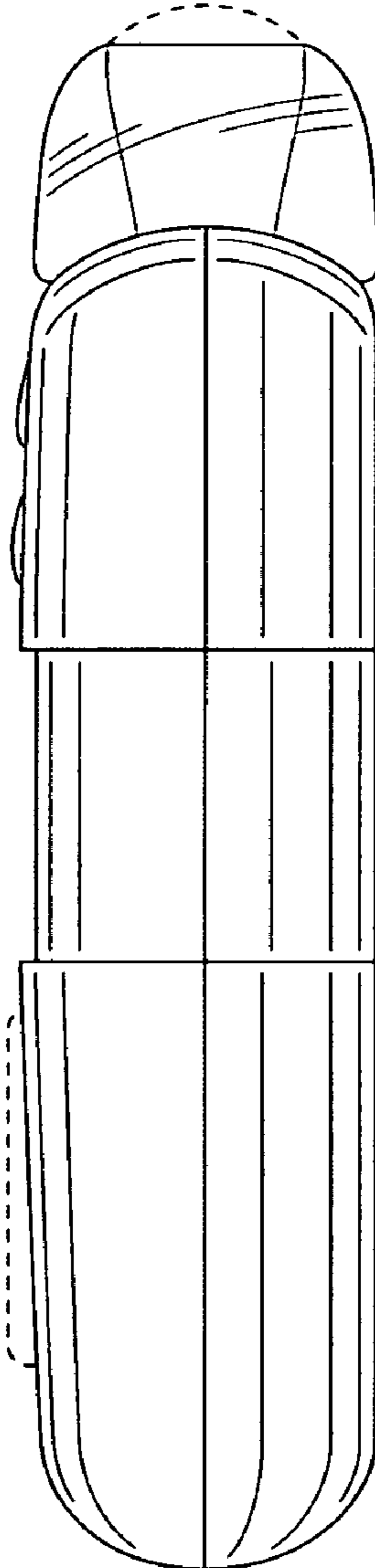

FIG. 5

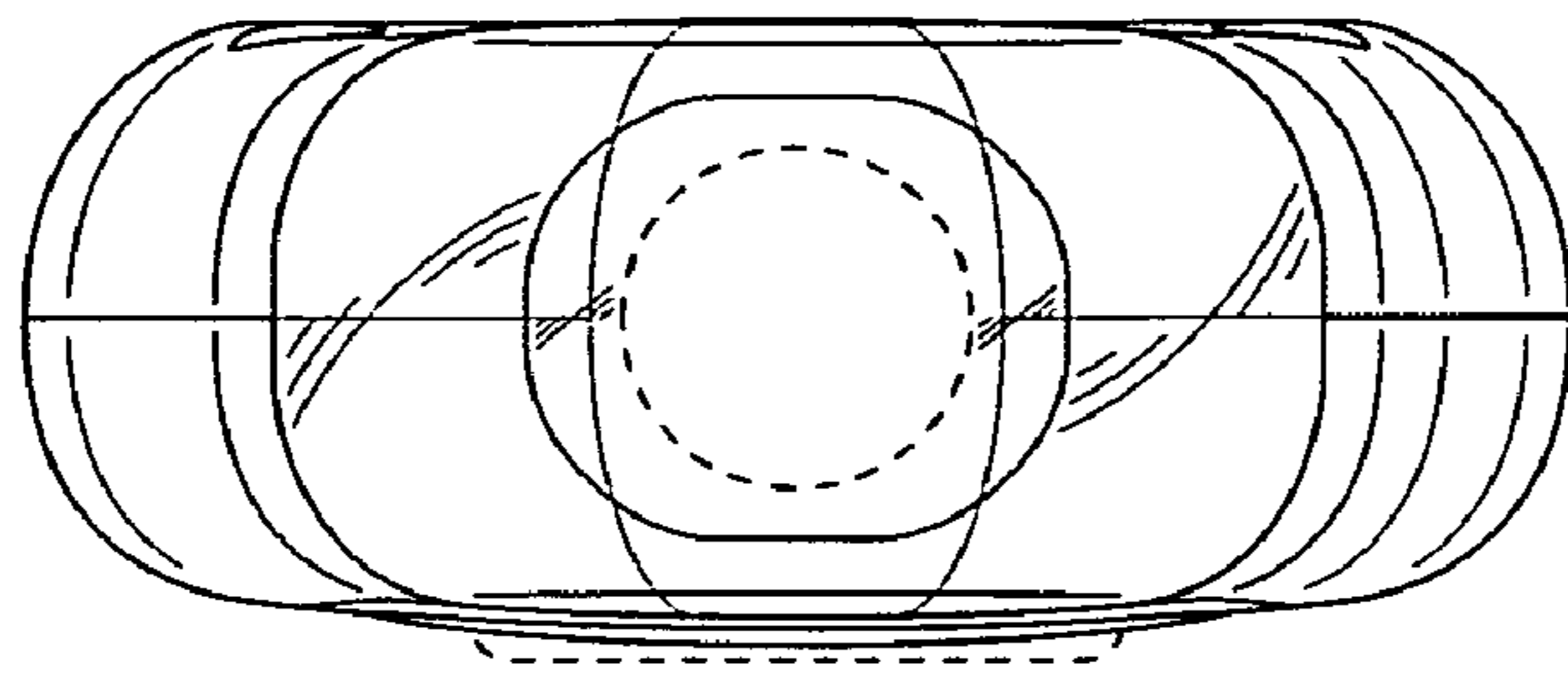

FIG. 6

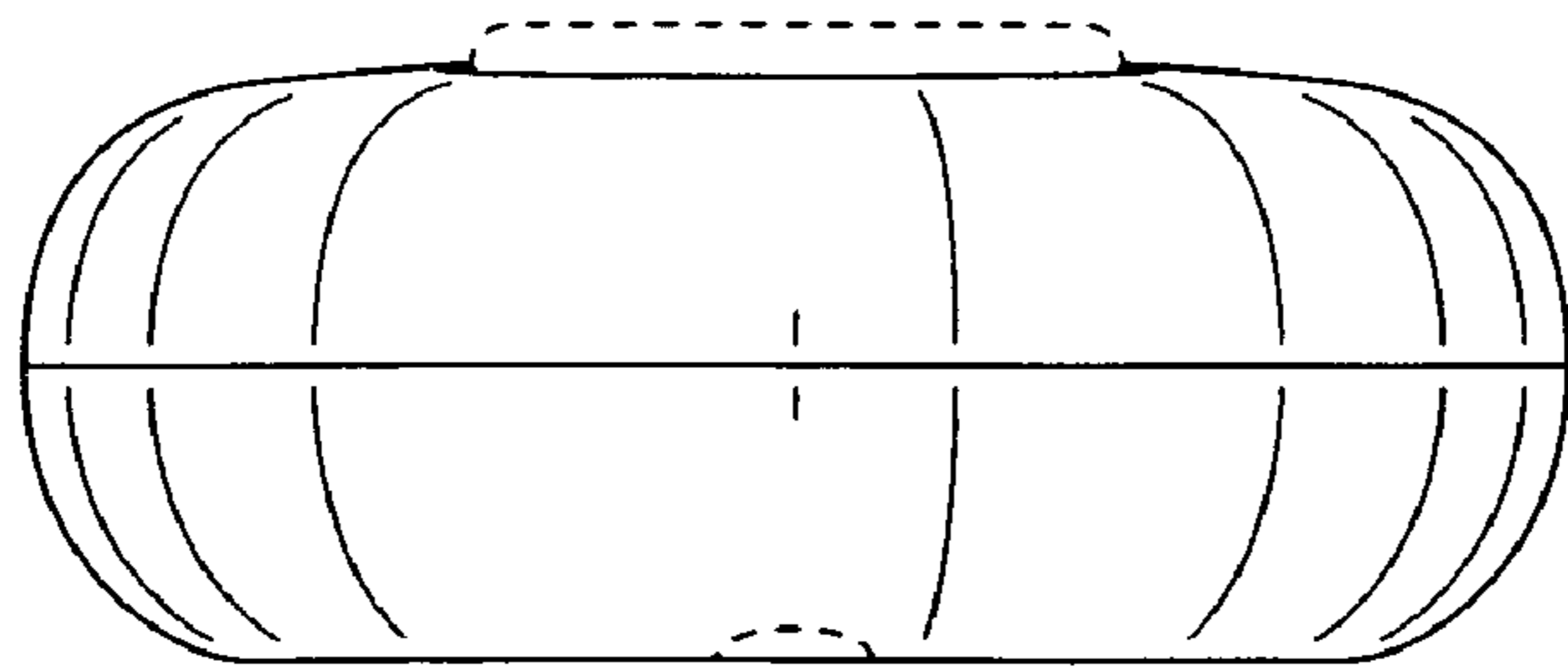

FIG. 7