



US00D658766S

(12) **United States Design Patent**  
**Otoha et al.**

(10) **Patent No.:** **US D658,766 S**  
(45) **Date of Patent:** **\*\* May 1, 2012**

(54) **PORTION OF AN ULTRASONIC DIAGNOSIS DEVICE**

(75) Inventors: **Shigeru Otoha**, Tokyo (JP); **Atsunobu Banryu**, Funabashi (JP)

(73) Assignees: **Kabushiki Kaisha Toshiba**, Minato-ku, Tokyo (JP); **Toshiba Medical Systems Corporation**, Otawara-shi, Tochigi-ken (JP)

(\*\*) Term: **14 Years**

(21) Appl. No.: **29/399,949**

(22) Filed: **Aug. 22, 2011**

(30) **Foreign Application Priority Data**

May 18, 2011 (JP) ..... 2011-011088

(51) **LOC (9) Cl.** ..... **24-01**

(52) **U.S. Cl.** ..... **D24/185**

(58) **Field of Classification Search** ..... D24/158-161, D24/185, 177; 378/4, 15, 17, 20, 21, 23-27, 378/62, 68, 146; 128/916, 922; 600/437, 600/440, 442, 443; D8/356

See application file for complete search history.

(56) **References Cited**

**U.S. PATENT DOCUMENTS**

D288,122 S *	2/1987	McGaha et al. ....	D24/177
D318,919 S *	8/1991	Takaki et al. ....	D24/186
D328,791 S *	8/1992	Nordstrom et al. ....	D24/177
D354,136 S *	1/1995	Phelps et al. ....	D24/177
D354,353 S *	1/1995	Ishizuka et al. ....	D24/160
D360,690 S *	7/1995	Murakami ....	D24/186
D361,620 S *	8/1995	Phleps et al. ....	D24/177
D365,148 S *	12/1995	Murakami et al. ....	D24/160
D375,450 S *	11/1996	Bidwell et al. ....	D8/356
D378,416 S *	3/1997	LaPlante et al. ....	D24/177
D379,231 S *	5/1997	Ungari ....	D24/160
D383,968 S *	9/1997	Bidwell et al. ....	D8/356
D391,838 S *	3/1998	Bidwell et al. ....	D8/356

D394,712 S *	5/1998	Henderson et al. ....	D24/160
D398,059 S *	9/1998	Kwak ....	D24/160
5,941,824 A *	8/1999	Hwang ....	600/437
D458,379 S *	6/2002	Brockway et al. ....	D24/177
D480,810 S *	10/2003	Gumisawa ....	D24/158
6,669,639 B1 *	12/2003	Miller et al. ....	600/443
D498,847 S *	11/2004	Castellini ....	D24/177
D512,508 S *	12/2005	Mesaros ....	D24/185
D529,611 S *	10/2006	Gumisawa et al. ....	D24/158
D554,264 S *	10/2007	Watson et al. ....	D24/186
D555,247 S *	11/2007	Castellini ....	D24/177
D560,807 S *	1/2008	Kitayama et al. ....	D24/158
D571,011 S *	6/2008	Otoha et al. ....	D24/158
D606,202 S *	12/2009	Banryu ....	D24/185
D609,349 S *	2/2010	Pelissier et al. ....	D24/186
D626,236 S *	10/2010	Ninomiya et al. ....	D24/185

(Continued)

**FOREIGN PATENT DOCUMENTS**

CH ZL200630018839.4 7/2007

(Continued)

*Primary Examiner* — T. Chase Nelson

*Assistant Examiner* — Mark Cavanna

(74) *Attorney, Agent, or Firm* — Banner & Witcoff, Ltd

(57) **CLAIM**

The ornamental design for a portion of an ultrasonic diagnosis device, as shown and described.

**DESCRIPTION**

FIG. 1 is a front, top and right side perspective view of a portion of an ultrasonic diagnosis device, showing our new design;

FIG. 2 is a front elevational view thereof;

FIG. 3 is a rear elevational view thereof;

FIG. 4 is a top plan view thereof;

FIG. 5 is a bottom plan view thereof;

FIG. 6 is a right side elevational view thereof; and,

FIG. 7 is a left side elevational view thereof.

The broken lines are included for the purpose of illustrating environment that forms no part of the claimed design.

**1 Claim, 7 Drawing Sheets**

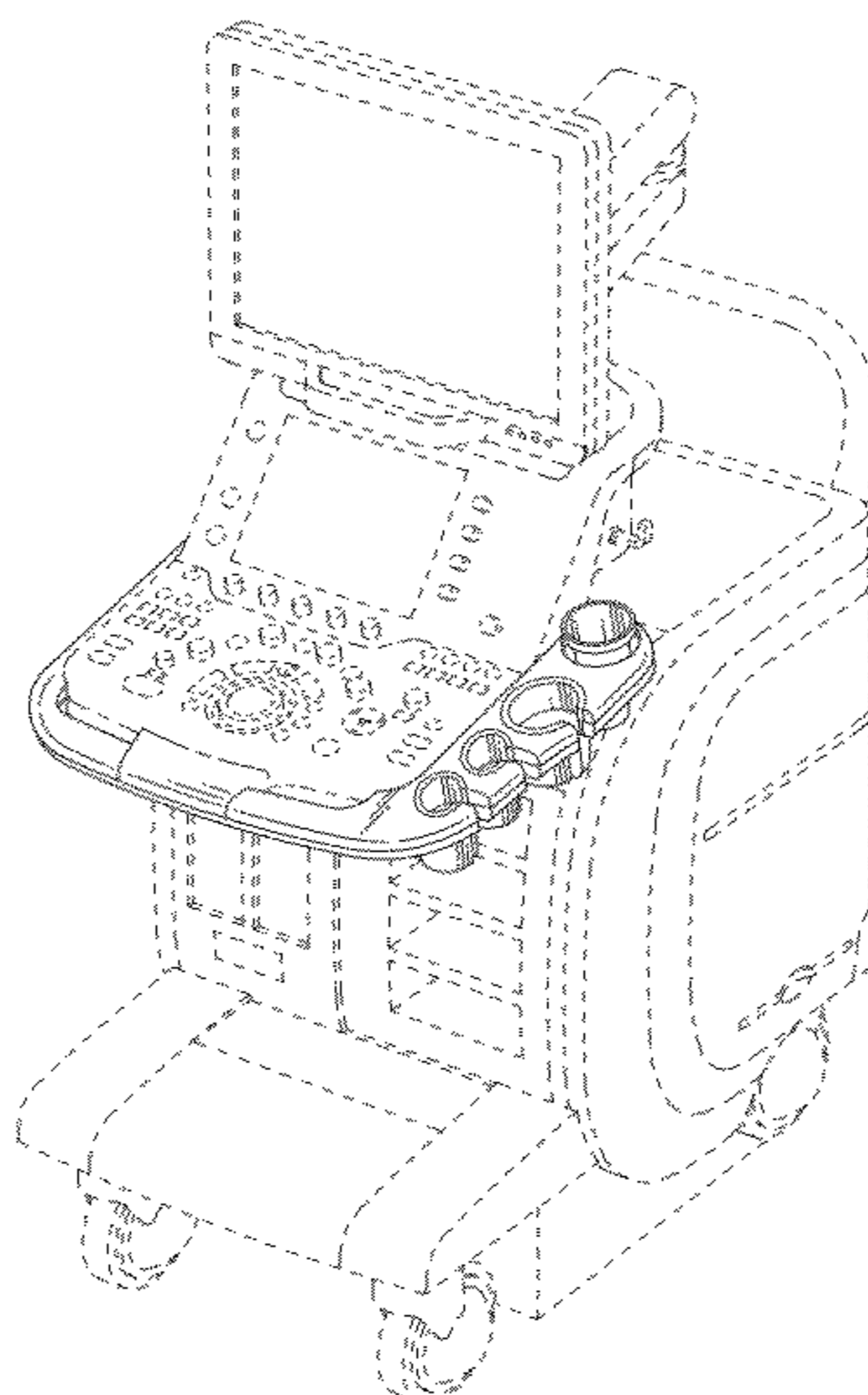

# US D658,766 S

Page 2

---

## U.S. PATENT DOCUMENTS

\* cited by examiner

D626,239 S	*	10/2010	Lia et al. ....	D24/185
D630,752 S	*	1/2011	Suzuki .....	D24/158
D650,482 S	*	12/2011	Kim et al. ....	D24/158

## FOREIGN PATENT DOCUMENTS

JP	1312301	10/2007
JP	1312302	10/2007
JP	1400868	11/2010

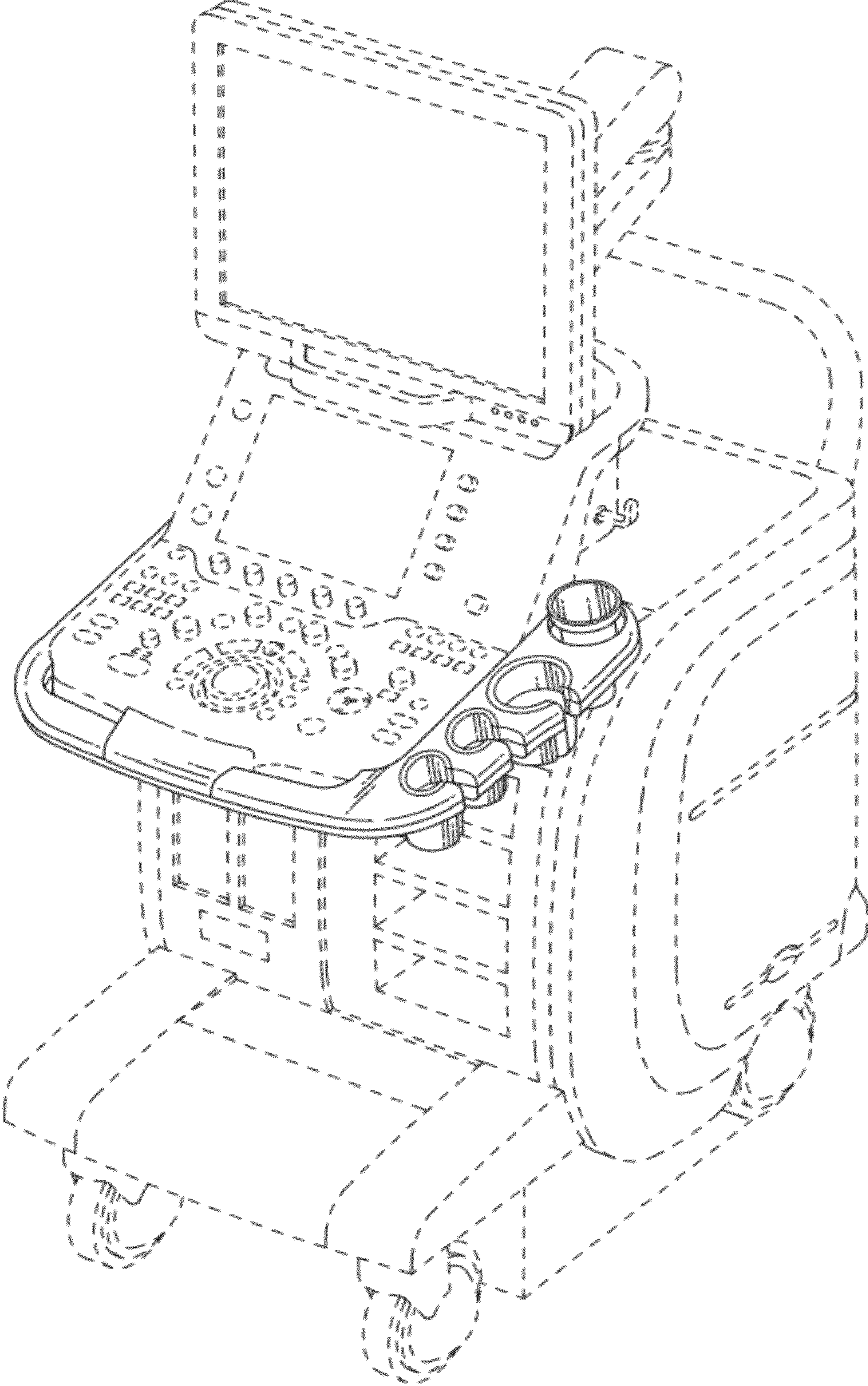

FIG.1

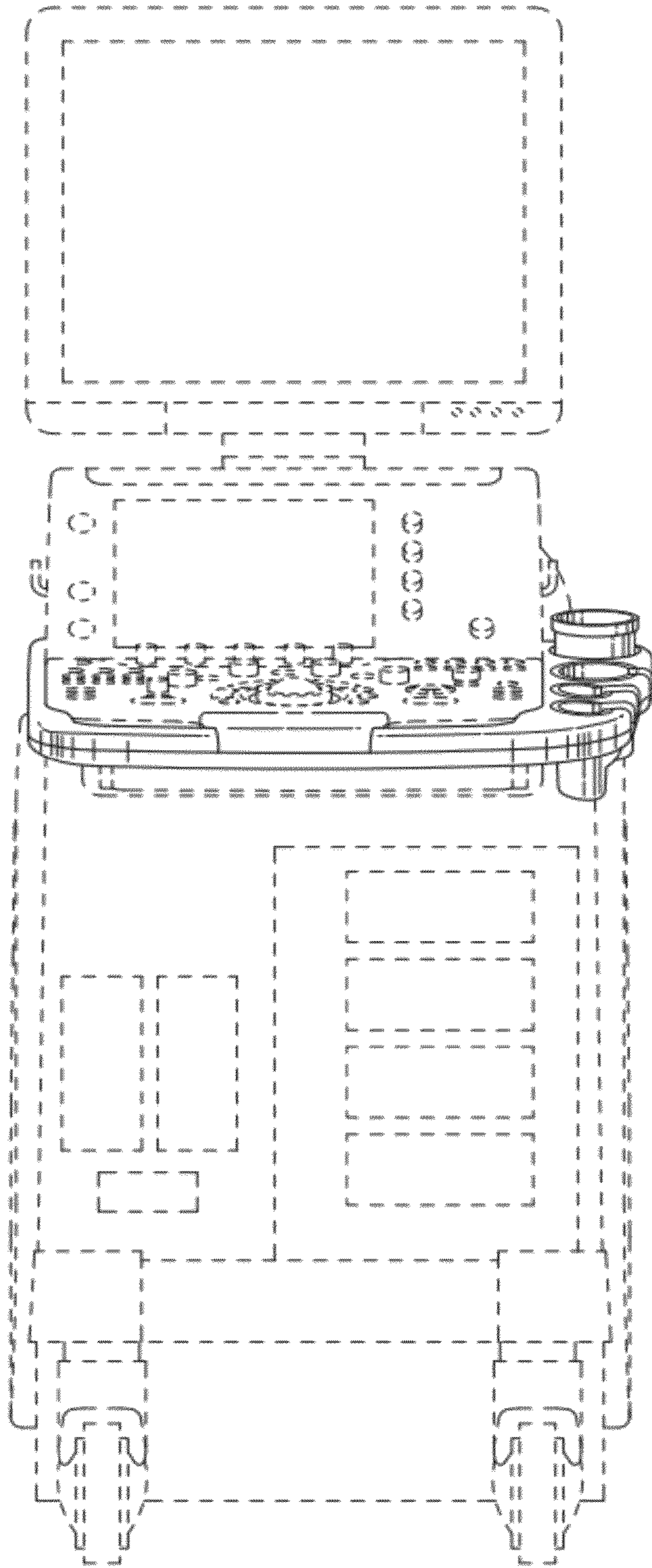

FIG. 2

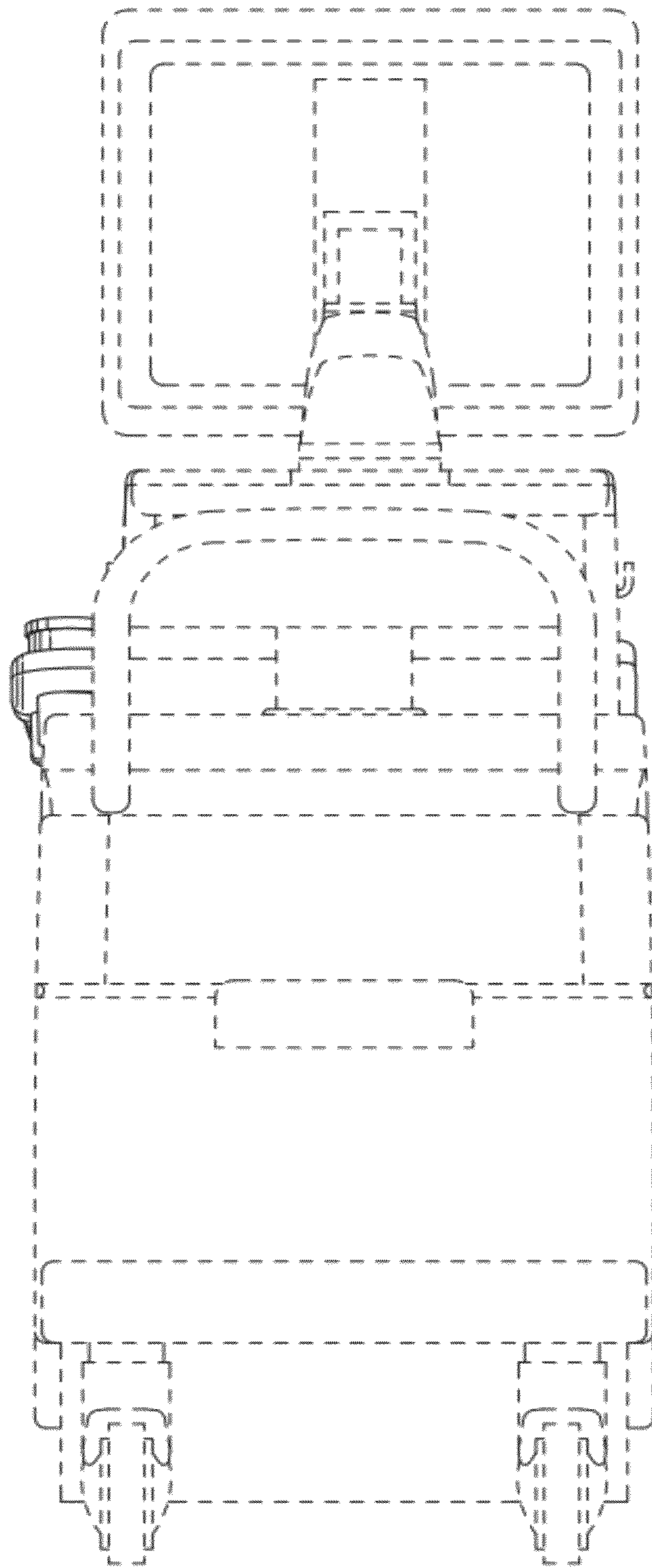

FIG.3

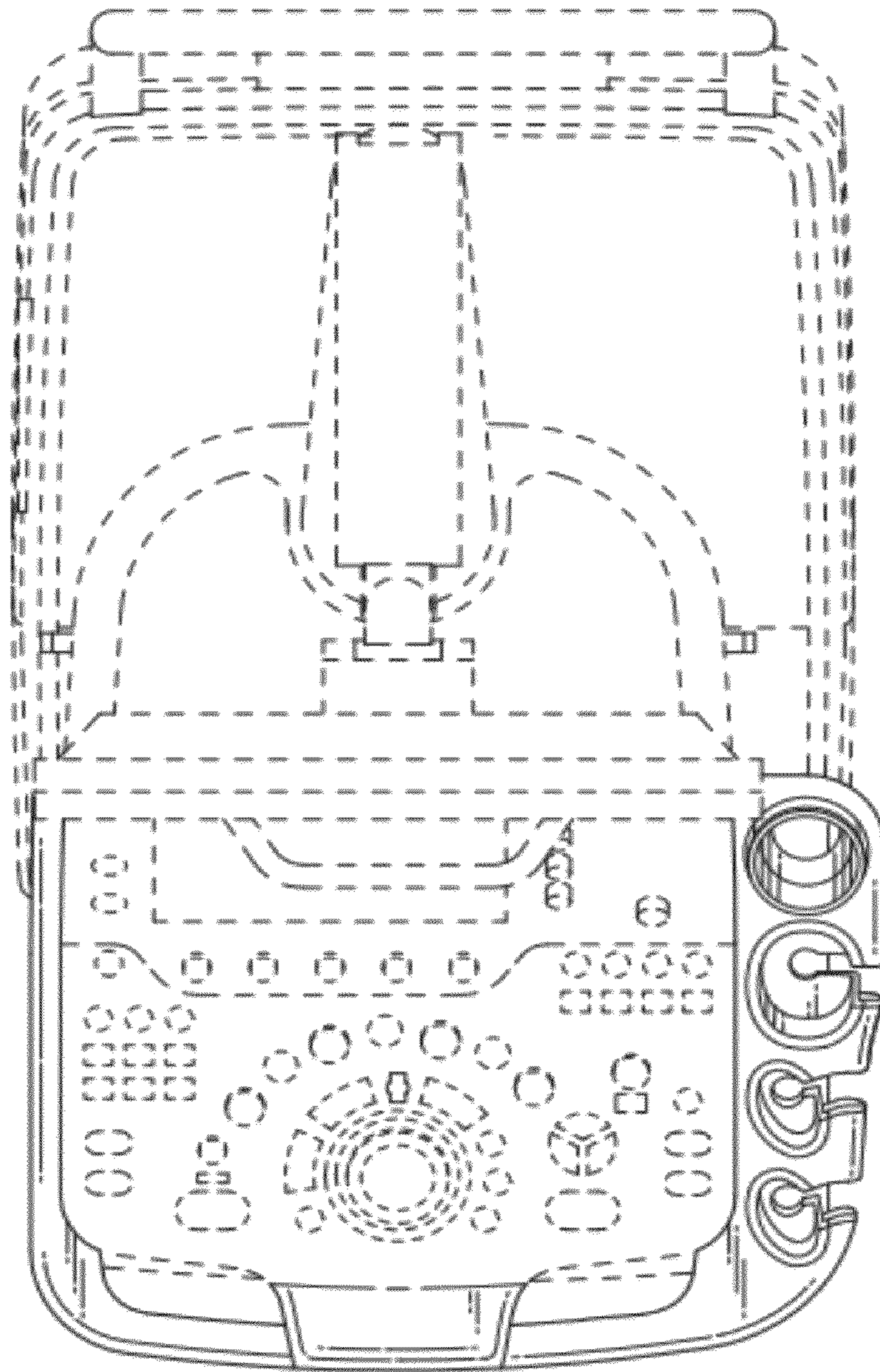

FIG.4

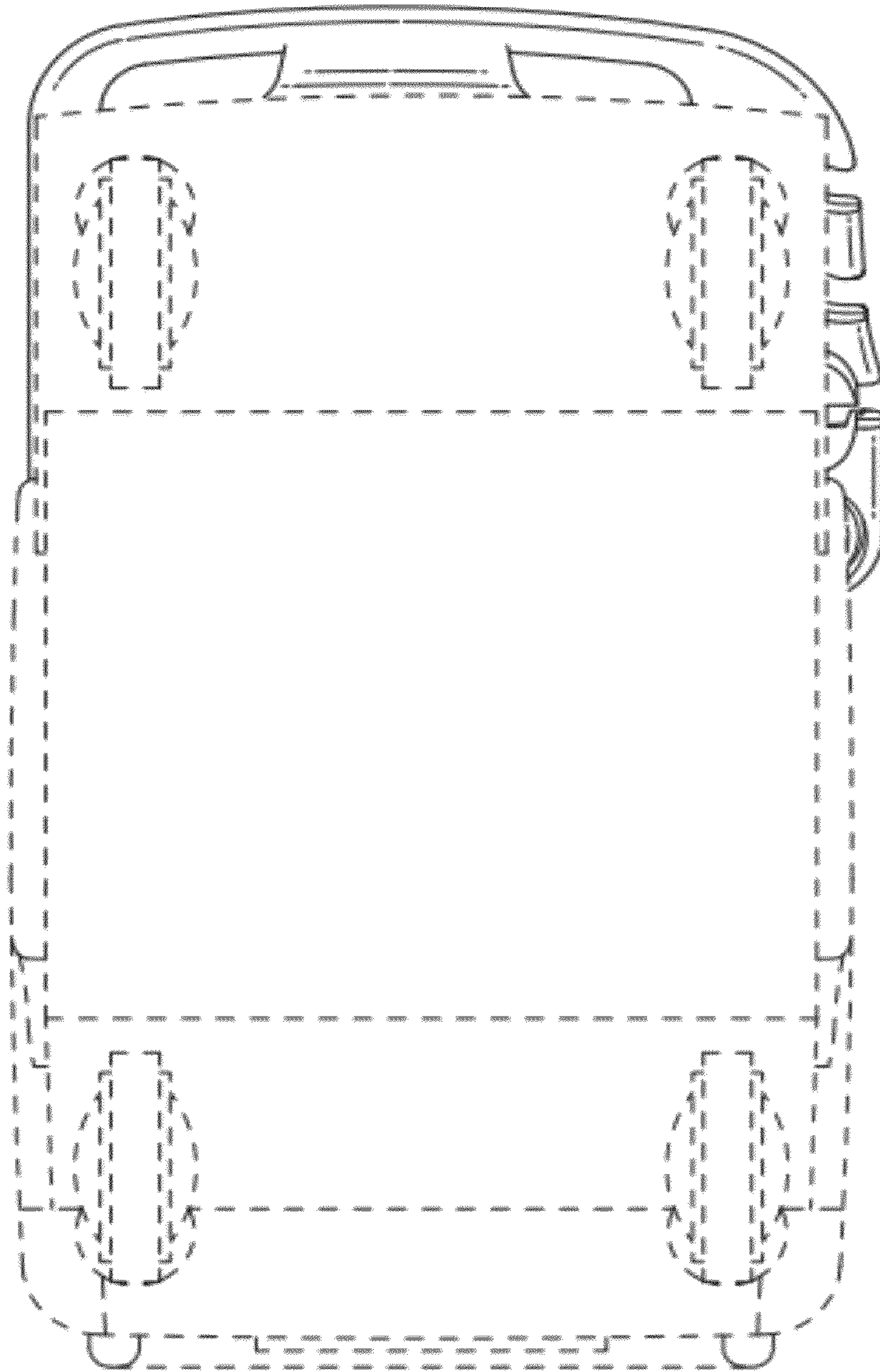

FIG. 5

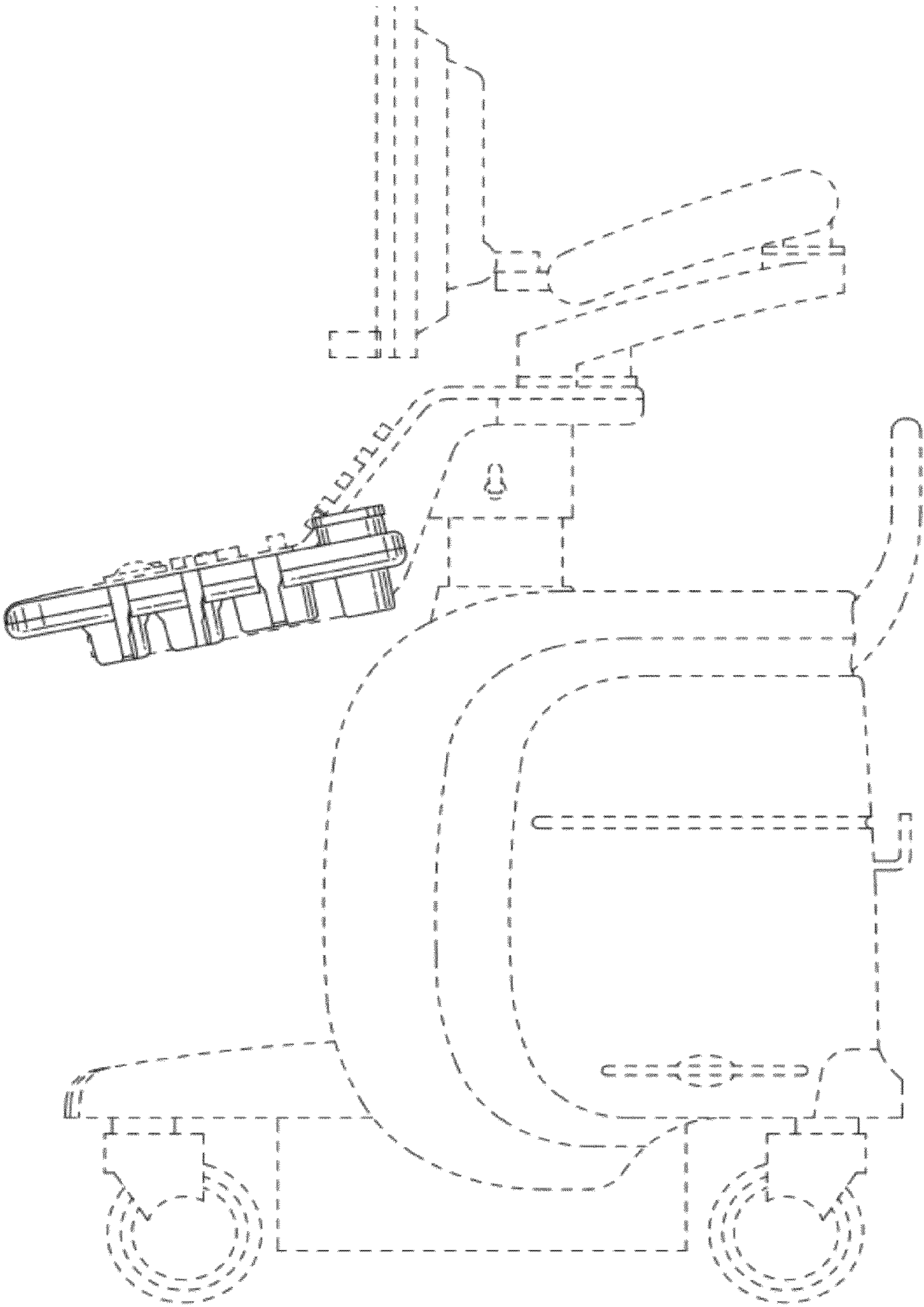

FIG. 6



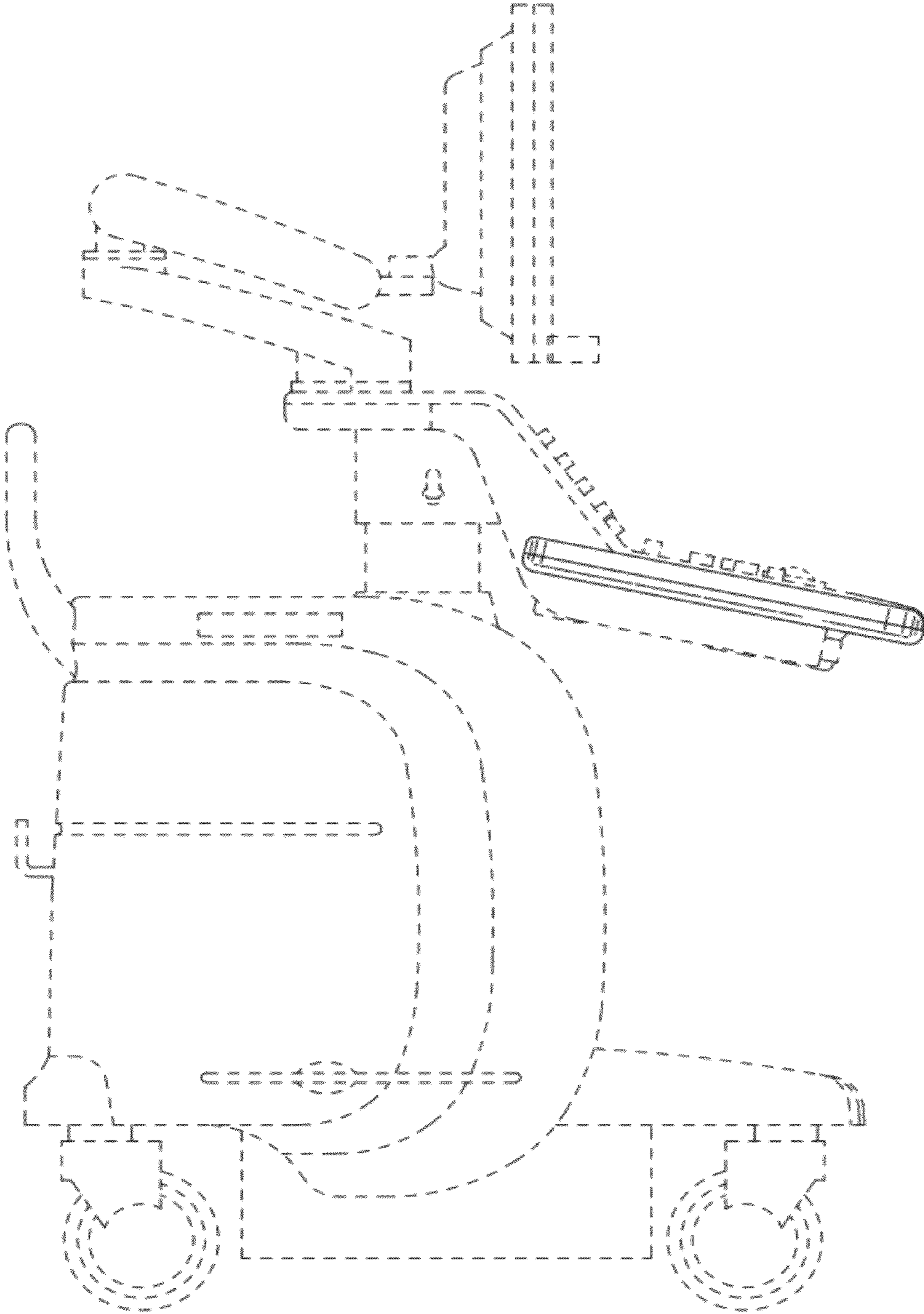

FIG.7