



US00D658720S

(12) **United States Design Patent Grant**

(10) **Patent No.:** **US D658,720 S**

(45) **Date of Patent:** **** May 1, 2012**

(54) **GAME BOARD WITH TRANSLUCENT GAME PIECES**

Primary Examiner — Sandra Morris

(74) *Attorney, Agent, or Firm* — Fish & Richardson P.C.

(76) Inventor: **Andrew P. Grant**, Greenfield, MA (US)

(57) **CLAIM**

The ornamental design for a game board with translucent game pieces, as shown and described.

(**) Term: **14 Years**

DESCRIPTION

(21) Appl. No.: **29/378,394**

(22) Filed: **Nov. 3, 2010**

(51) **LOC (9) Cl.** **21-01**

(52) **U.S. Cl.** **D21/341; D21/364**

(58) **Field of Classification Search** D19/60–62;
D21/334–368; 273/236–288; 434/128–129
See application file for complete search history.

FIG. 1 is a front perspective view of a game board of the design, the rear perspective view being the same.

FIG. 2 is a side view of the game board and cover of FIG. 1, the opposite side view being the same.

FIG. 3 is an end view of the game board and cover of FIG. 1, the opposite end view being the same.

FIG. 4 is top plan view of the game board of FIG. 1, with pockets located at each corner of the game board, e.g., for accommodating translucent game pieces.

FIG. 5 is a bottom plan view of the game board of FIG. 1, which is not a feature of the claimed design and is shown without shading.

FIG. 6 is a front perspective view of the game board and cover of FIG. 1, with translucent game pieces placed in each pocket.

FIG. 7 is a top plan view of a translucent game piece of FIG. 6.

FIG. 8 is a side view of the translucent game piece of FIG. 7, all other side views being the same.

FIG. 9 is a bottom view of the translucent game piece of FIG. 7; and,

FIG. 10 is a front perspective view of a second embodiment thereof, showing translucent game pieces of contrasting color.

The purpose of broken lines in the drawing, including broken lines internal to the coaxial connector, merely illustrate environmental structure or boundaries that form no part of the design to be patented via the present application.

(56) **References Cited**

U.S. PATENT DOCUMENTS

1,623,881	A *	4/1927	Mayer	273/264
2,717,156	A *	9/1955	Nelson	273/248
D319,475	S *	8/1991	Gysels	D21/348
D362,027	S *	9/1995	Nelson	D21/341
D549,288	S *	8/2007	Droznika	D21/341
D551,303	S *	9/2007	McAllister	D21/345

OTHER PUBLICATIONS

Tri-King (1946), BoardGameGeek [online] [retrieved on May 18, 2011]. Retrieved from the Internet: <URL:<http://www.boardgamegeek.com/boardgame/22726/tri-king>, 3 pages.

Hex (board game), Wikipedia [online], [retrieved on May 18, 2011]. Retrieved from the Internet: <URL:http://en.wikipedia.org/wiki/Hex_(board_game)#Variants>, 1 page.

Diamond Bridge (2009), BoardGameGeek [online] [retrieved on May 18, 2011]. Retrieved from the Internet: <URL:http://www.boardgamegeek.com/boardgame/69625/diamond-bridge, 3 pages.

* cited by examiner

1 Claim, 6 Drawing Sheets

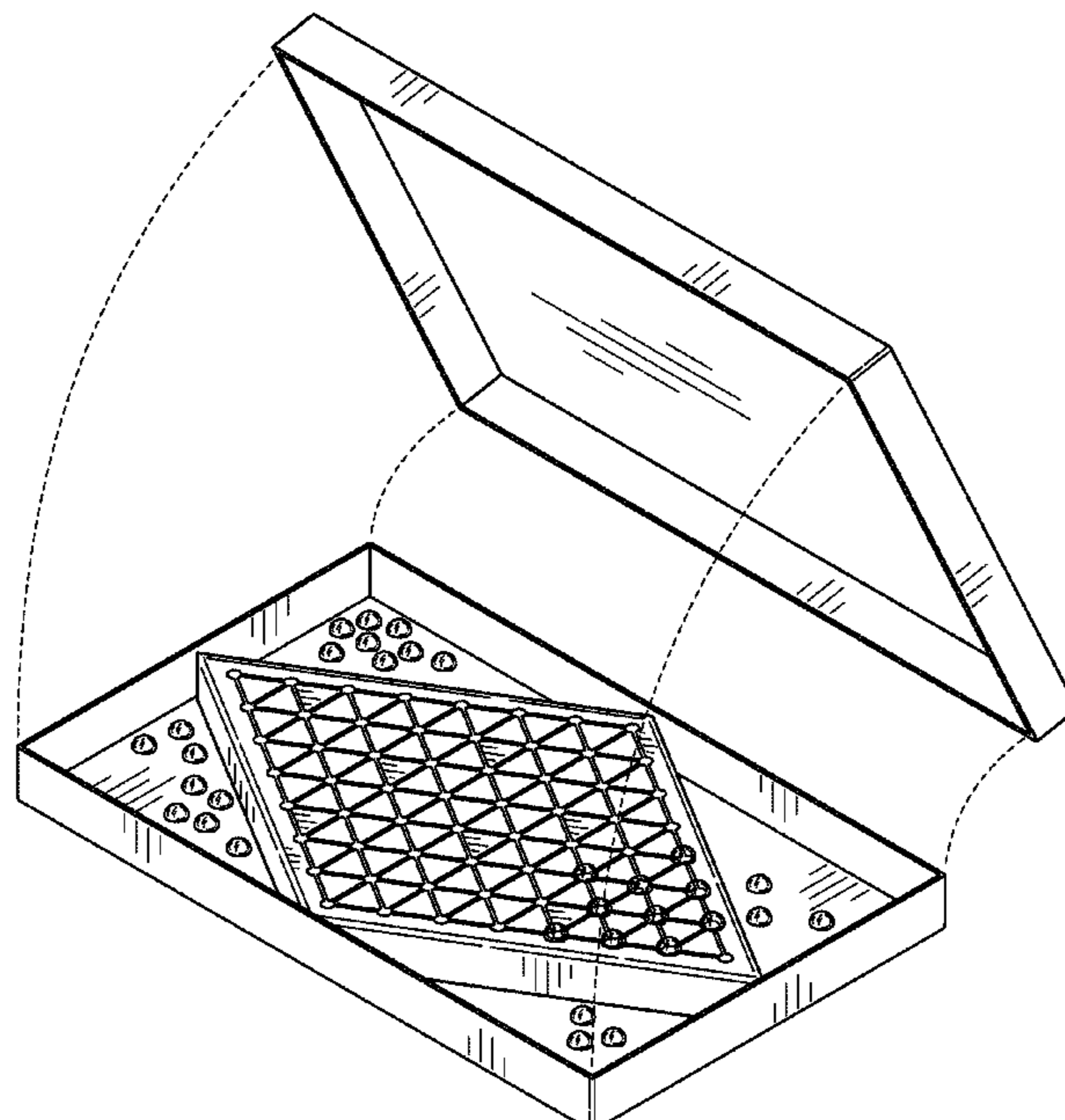

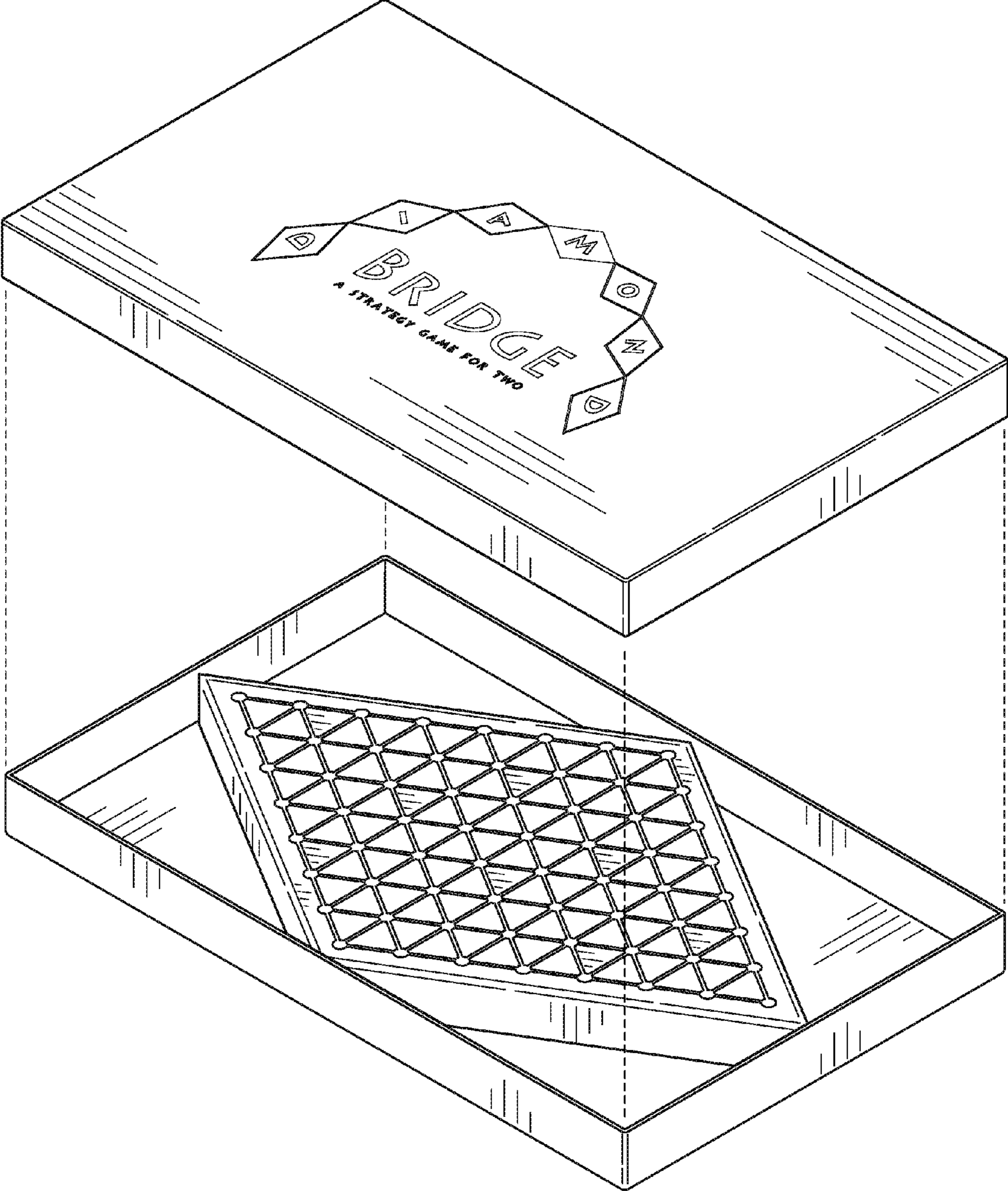

FIG. 1

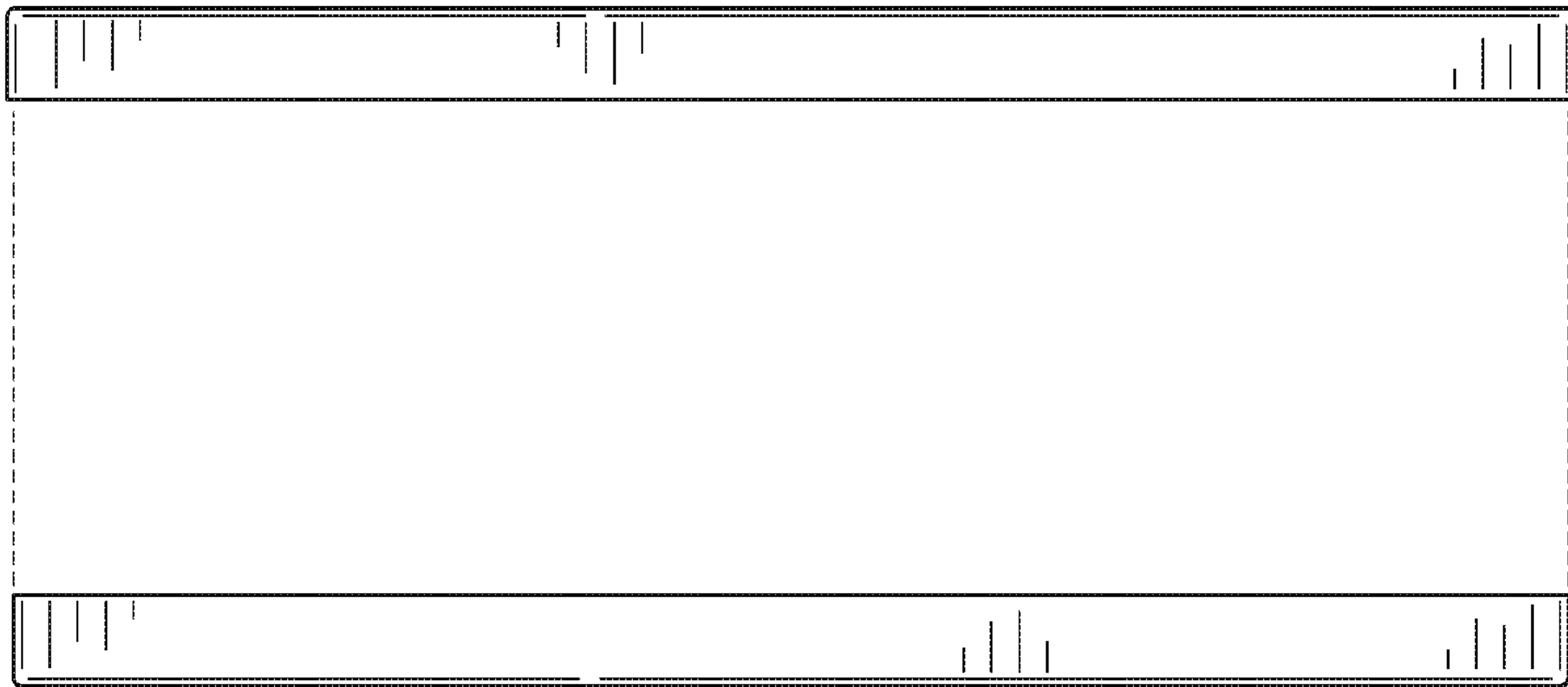

FIG. 2

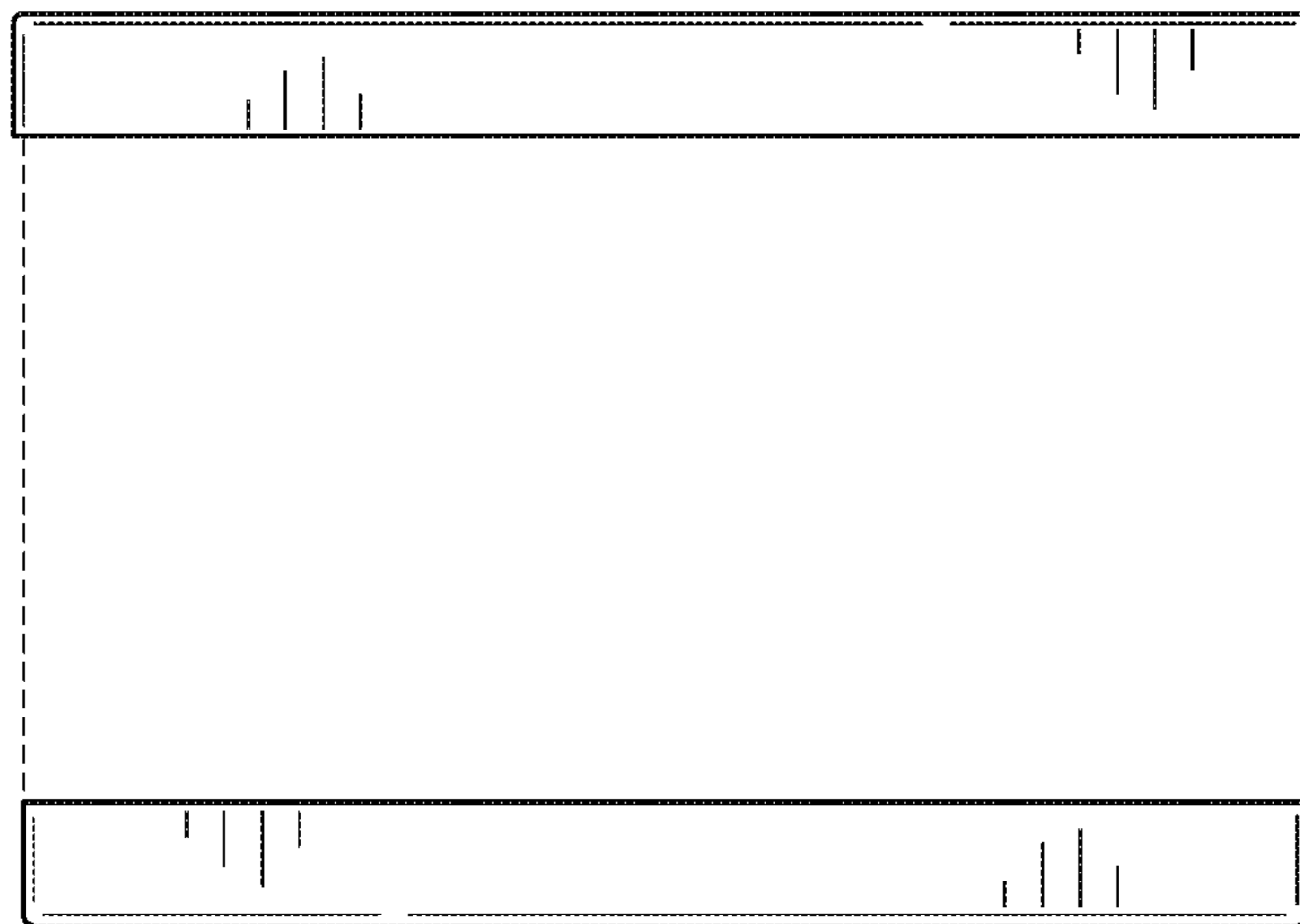

FIG. 3

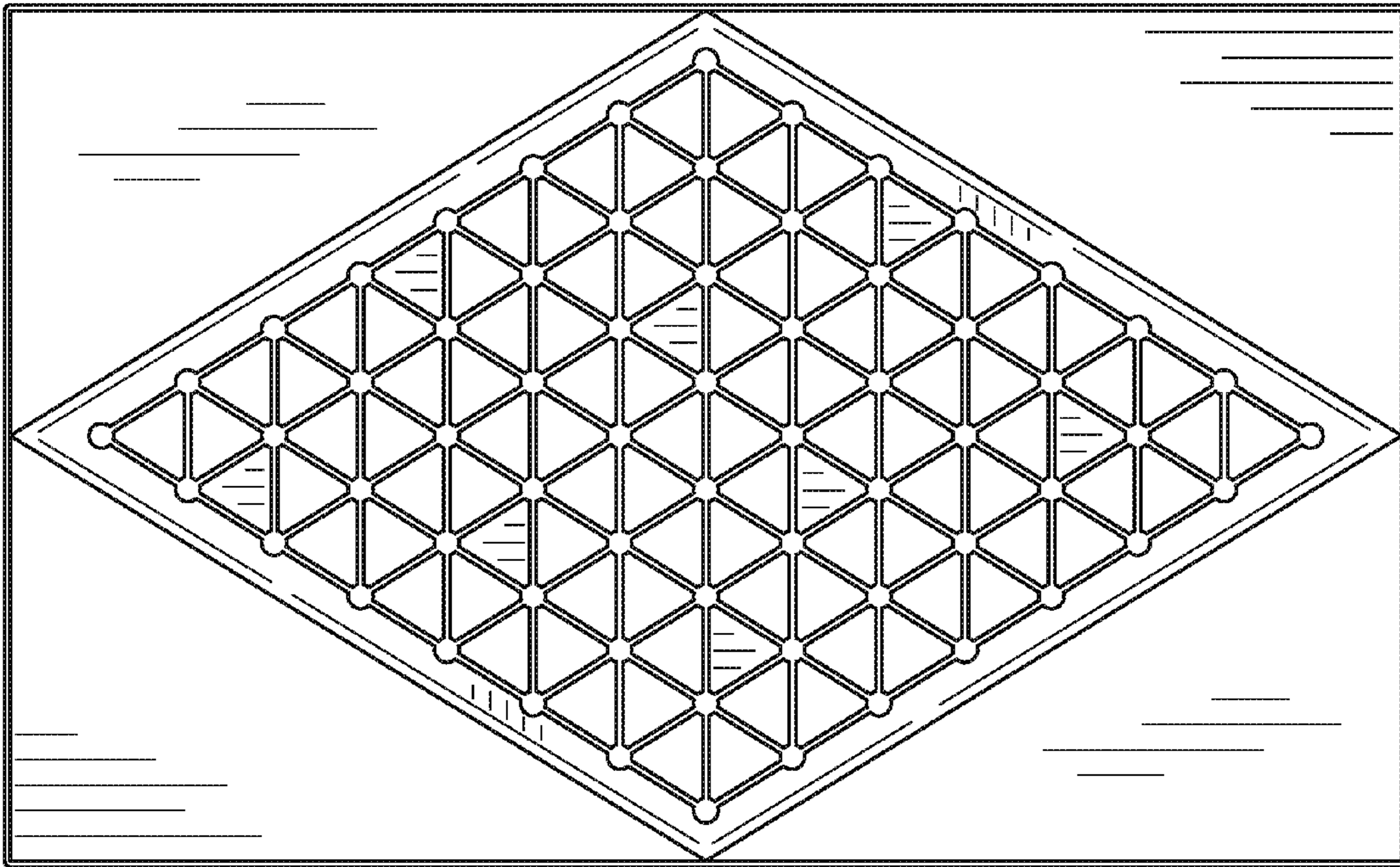

FIG. 4

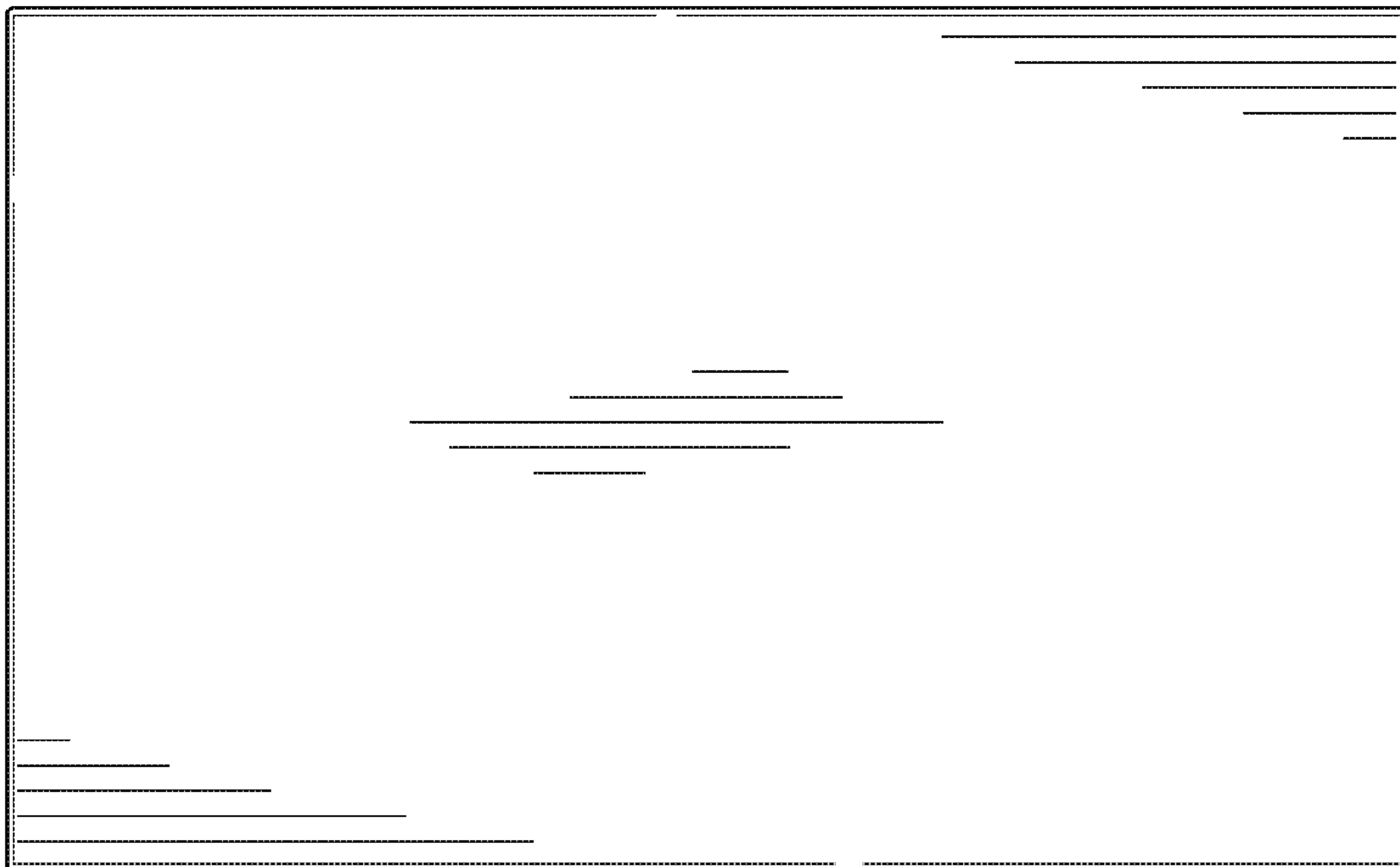

FIG. 5

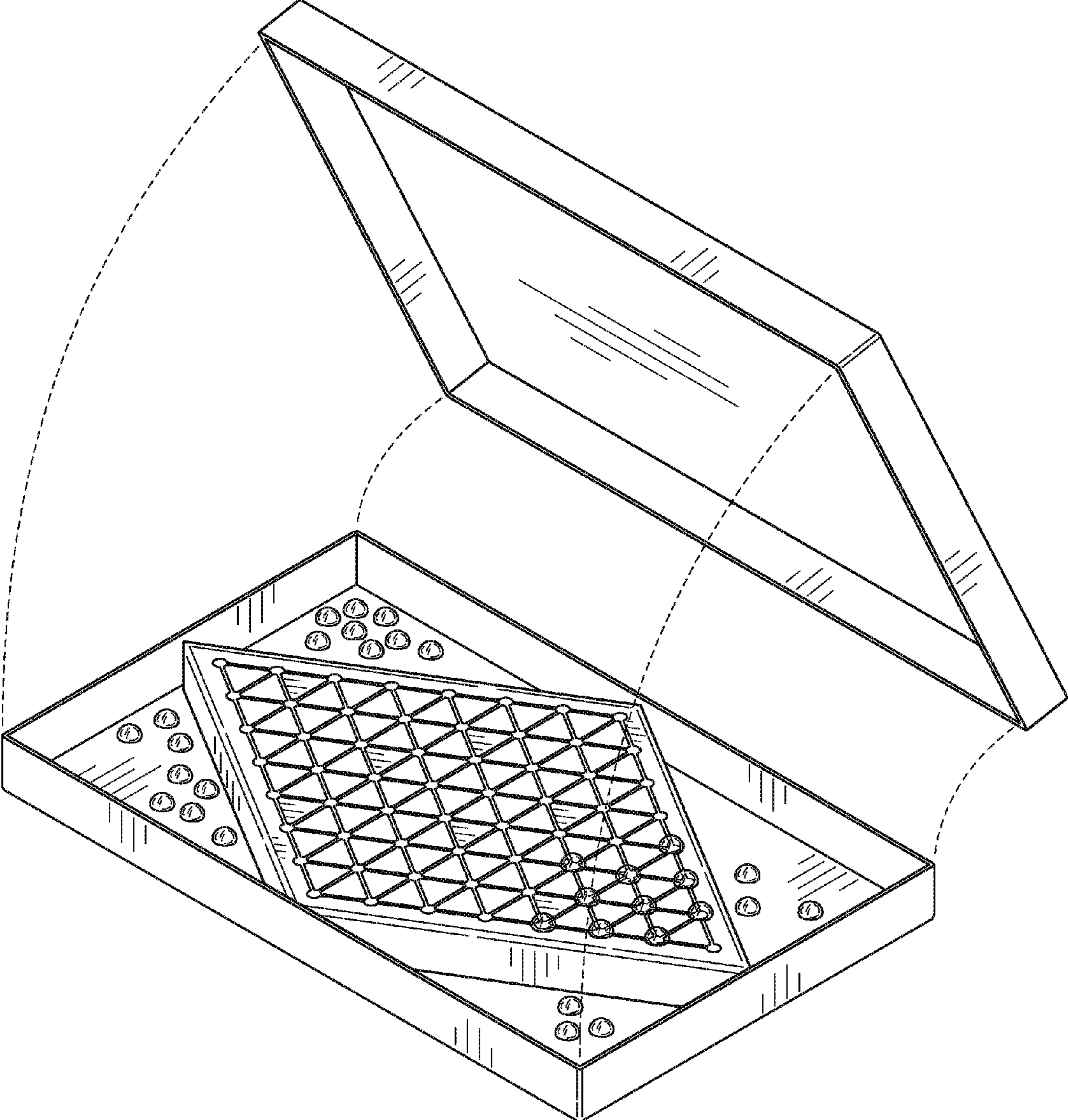

FIG. 6

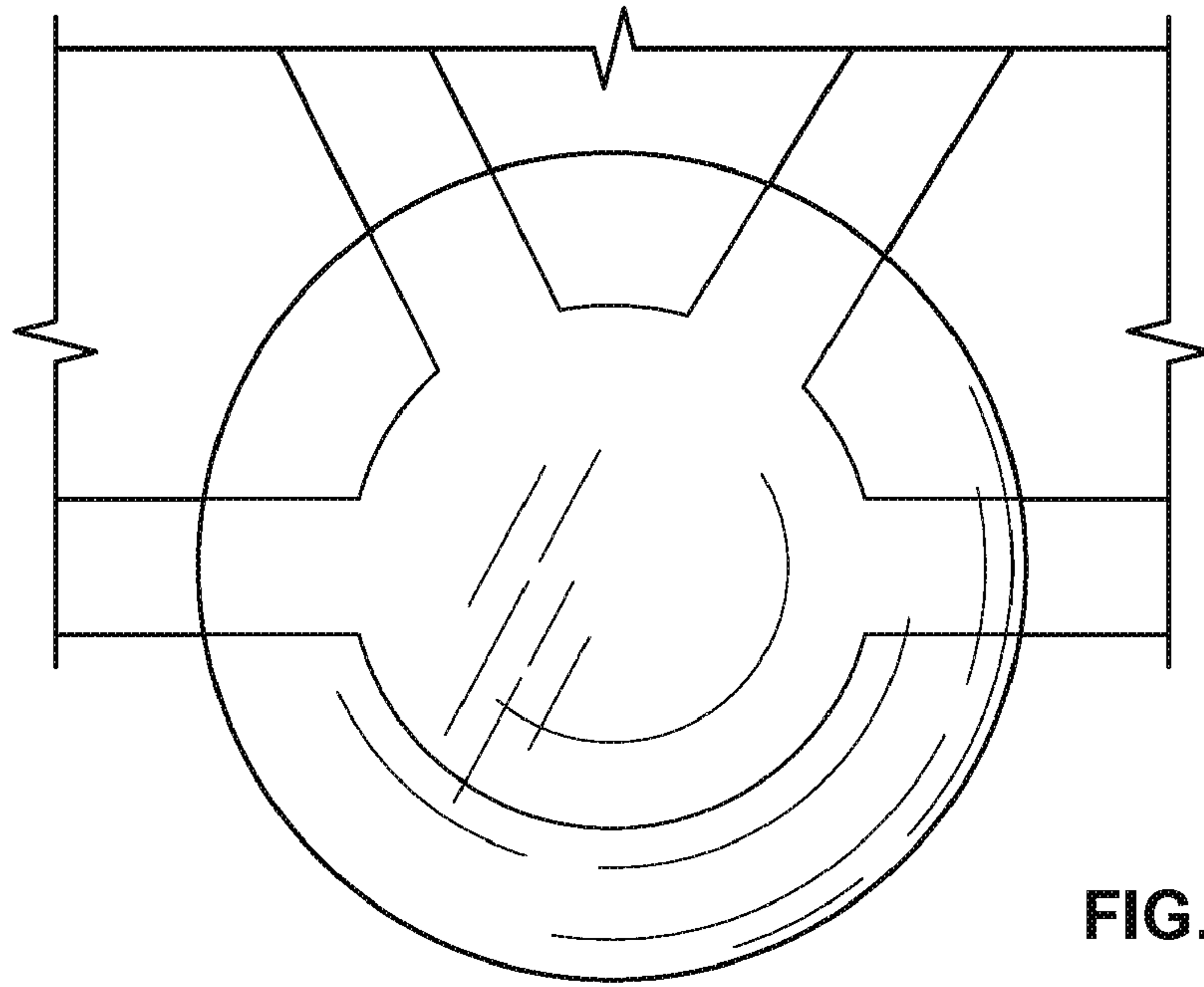

FIG. 7

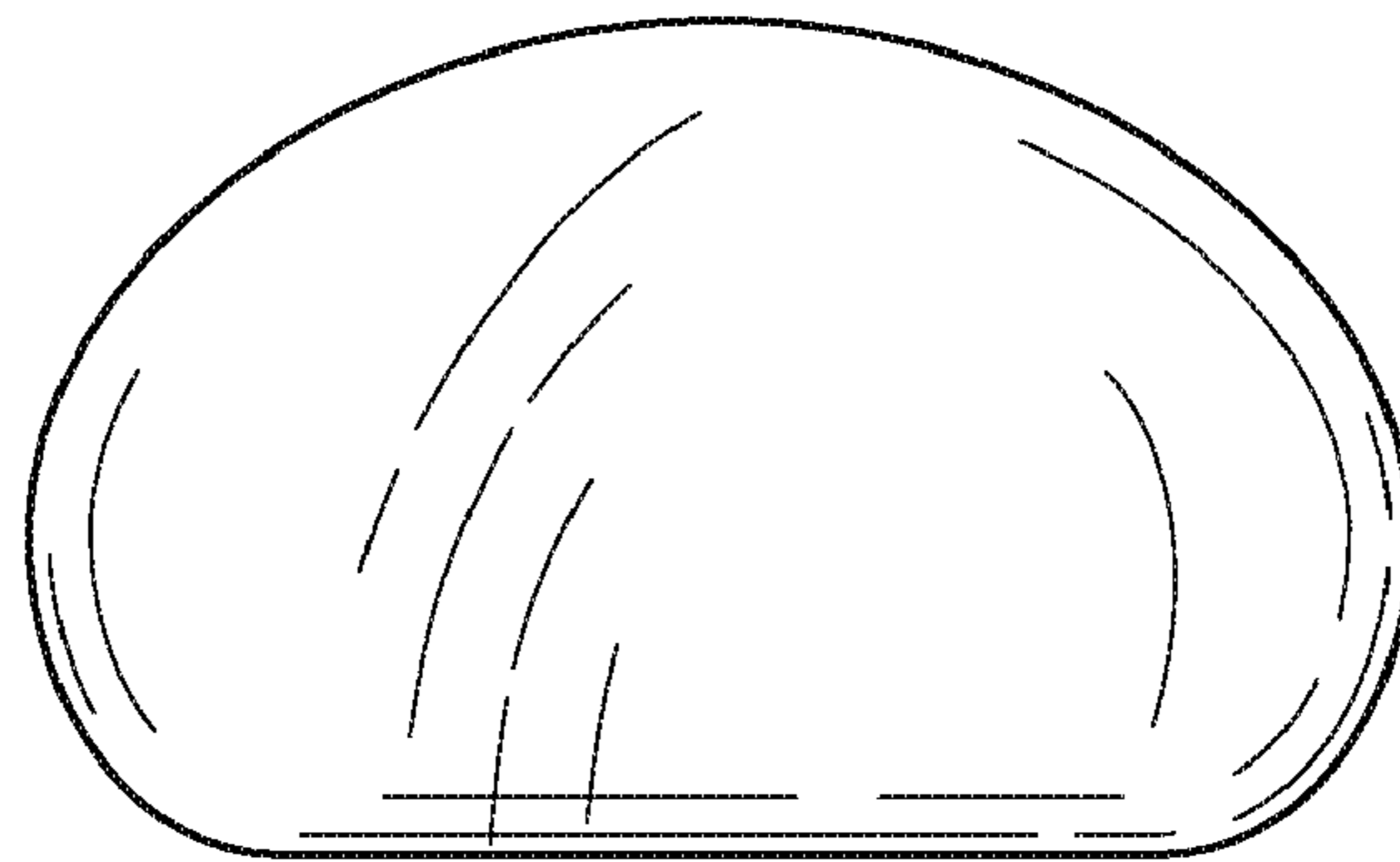

FIG. 8

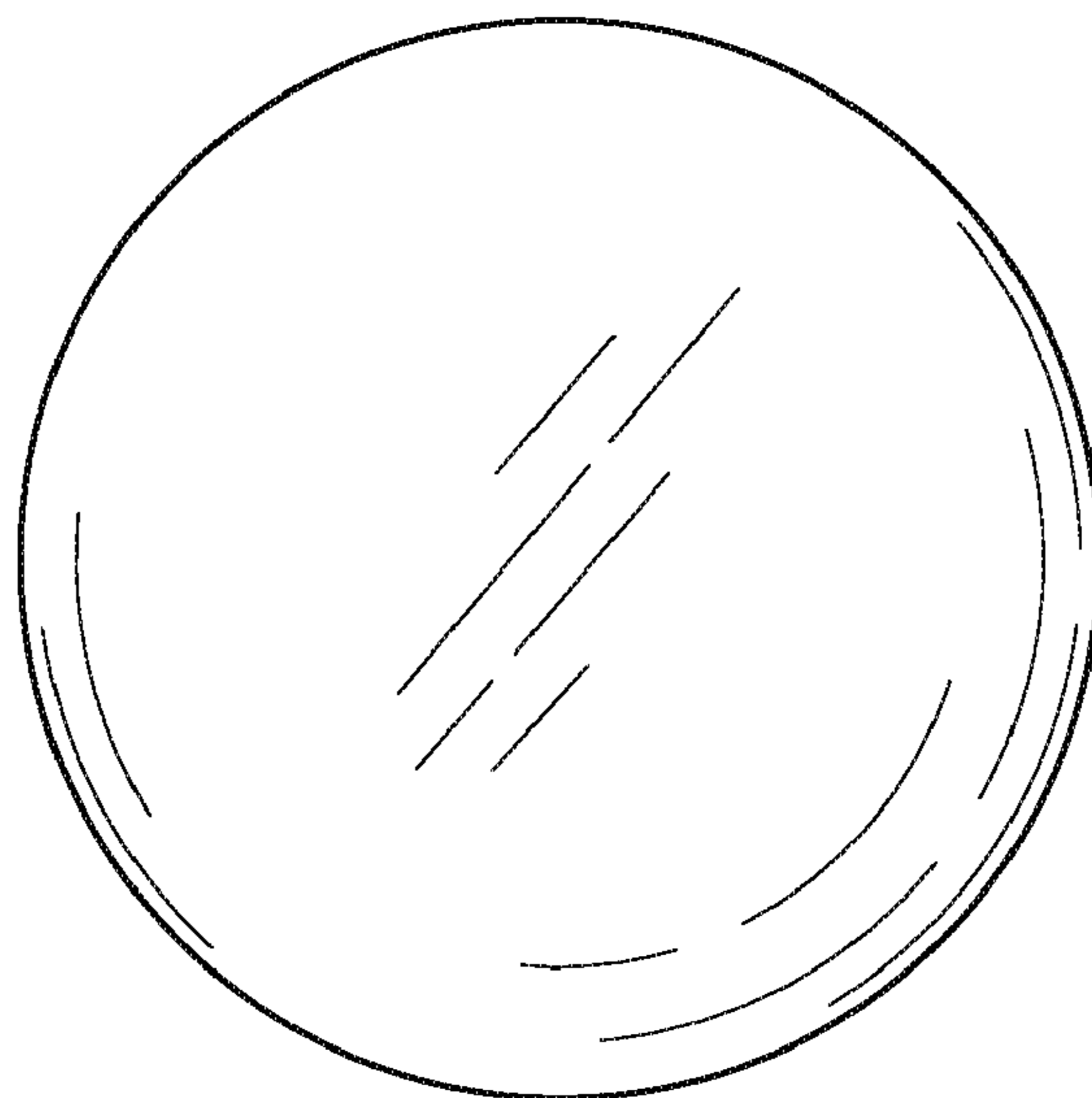

FIG. 9

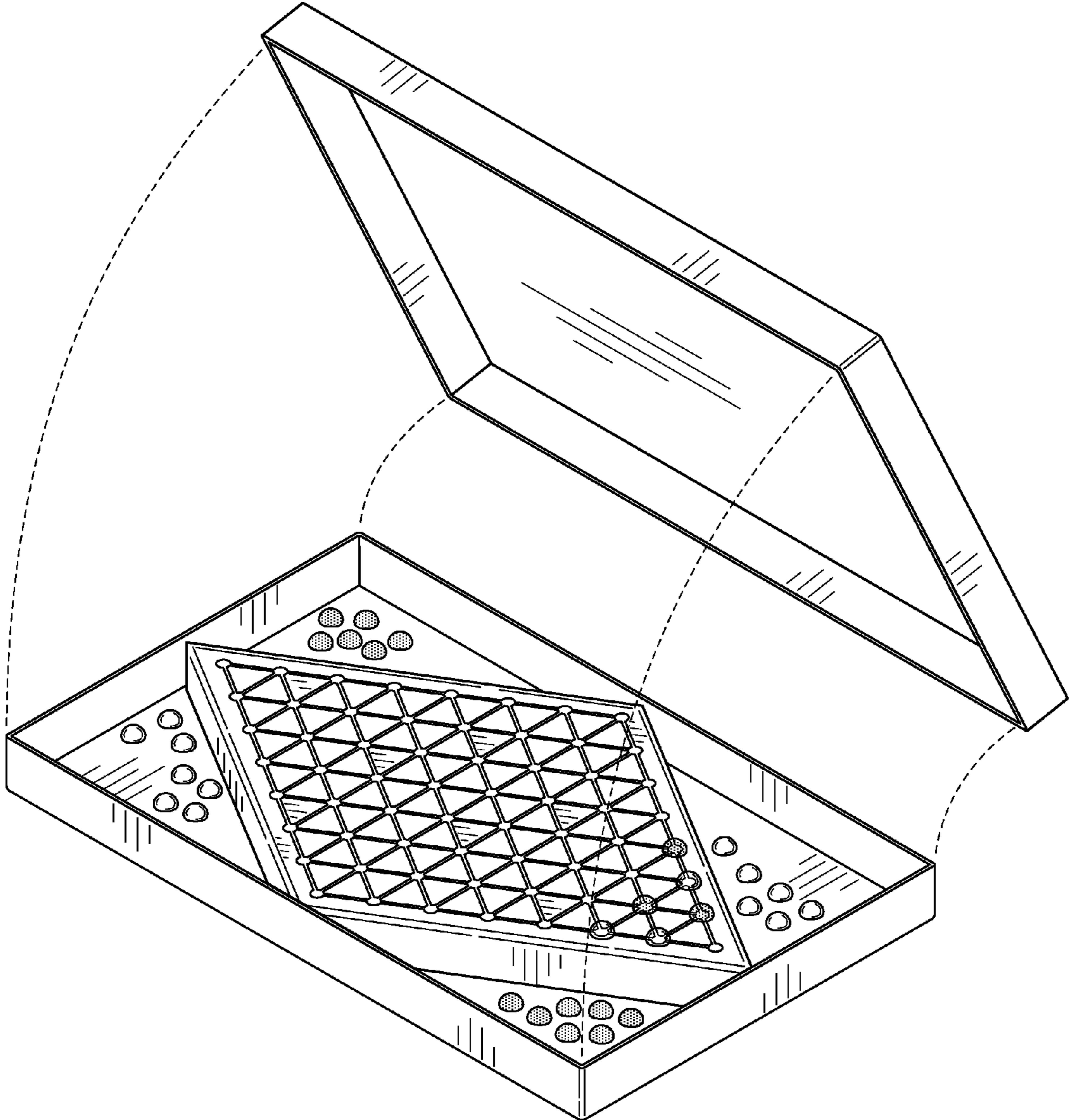

FIG. 10