



US00D658695S

(12) **United States Design Patent**  
**Schneider**

(10) **Patent No.:** **US D658,695 S**

(45) **Date of Patent:** **\*\* May 1, 2012**

(54) **CYLINDRICAL DEDUSTER WITH RADIAL AIR DISCHARGE**

*Primary Examiner* — Patricia Palasik  
(74) *Attorney, Agent, or Firm* — Miller Law Group, PLLC

(75) Inventor: **Heinz Schneider**, Lancaster, PA (US)

(73) Assignee: **Pelletron Corporation**, Lancaster, PA (US)

(57) **CLAIM**

(\*\*) Term: **14 Years**

The ornamental design for a cylindrical deduster with radial air discharge, as shown and described.

(21) Appl. No.: **29/369,404**

(22) Filed: **Sep. 8, 2010**

**DESCRIPTION**

(51) **LOC (9) Cl.** ..... **15-09**

(52) **U.S. Cl.** ..... **D15/147**

(58) **Field of Classification Search** ..... D15/145–147,  
D15/199; 83/24, 56, 168, 422, 925 C; 209/11,  
209/721, 728, 732, 734; 210/175, 512.2,  
210/787

See application file for complete search history.

FIG. 1 is a front perspective view of the cylindrical deduster, the cylindrical housing having a circular discharge member oriented radially and being mounted on an upper transparent cylindrical housing member, which is mounted on an opaque lower cylindrical housing member, the air inlet conduit being associated with the lower housing member and the radial air discharge conduit being associated with the circular discharge member, the flow adjustment knobs being shown in phantom and are not considered to be part of the design; FIG. 2 is a front elevational view thereof, the adjustment knobs being shown in phantom and is not part of the design; FIG. 3 is a rear elevational view thereof; FIG. 4 is a right side elevational view thereof; FIG. 5 is a left side elevational view thereof; FIG. 6 is a top plan view thereof, the conical infeed structure directing particulate material to the dedusting apparatus being shown with the discharge opening over the circular wash deck portion of the dedusting apparatus; and, FIG. 7 is a bottom plan view of the cylindrical deduster with radial air discharge housing.

(56) **References Cited**

U.S. PATENT DOCUMENTS

4,175,036	A *	11/1979	Frykhult	.....	209/734
4,541,934	A *	9/1985	Hakola	.....	210/787
4,581,965	A *	4/1986	Gerber	.....	83/24
4,652,363	A *	3/1987	Miller	.....	209/734
4,956,091	A *	9/1990	Van Den Akker	.....	210/512.2
5,305,889	A *	4/1994	Ganz	.....	209/734
5,951,877	A *	9/1999	Langley et al.	.....	210/782
D464,067	S *	10/2002	Rogers et al.	.....	D15/147
D585,922	S *	2/2009	Curran et al.	.....	D15/147
7,918,350	B2 *	4/2011	Min et al.	.....	210/512.1
2002/0112998	A1 *	8/2002	Bosman	.....	209/734
2010/0126320	A1 *	5/2010	Macomber et al.	.....	83/24
2011/0011796	A1 *	1/2011	Nickson	.....	210/512.2

\* cited by examiner

**1 Claim, 6 Drawing Sheets**

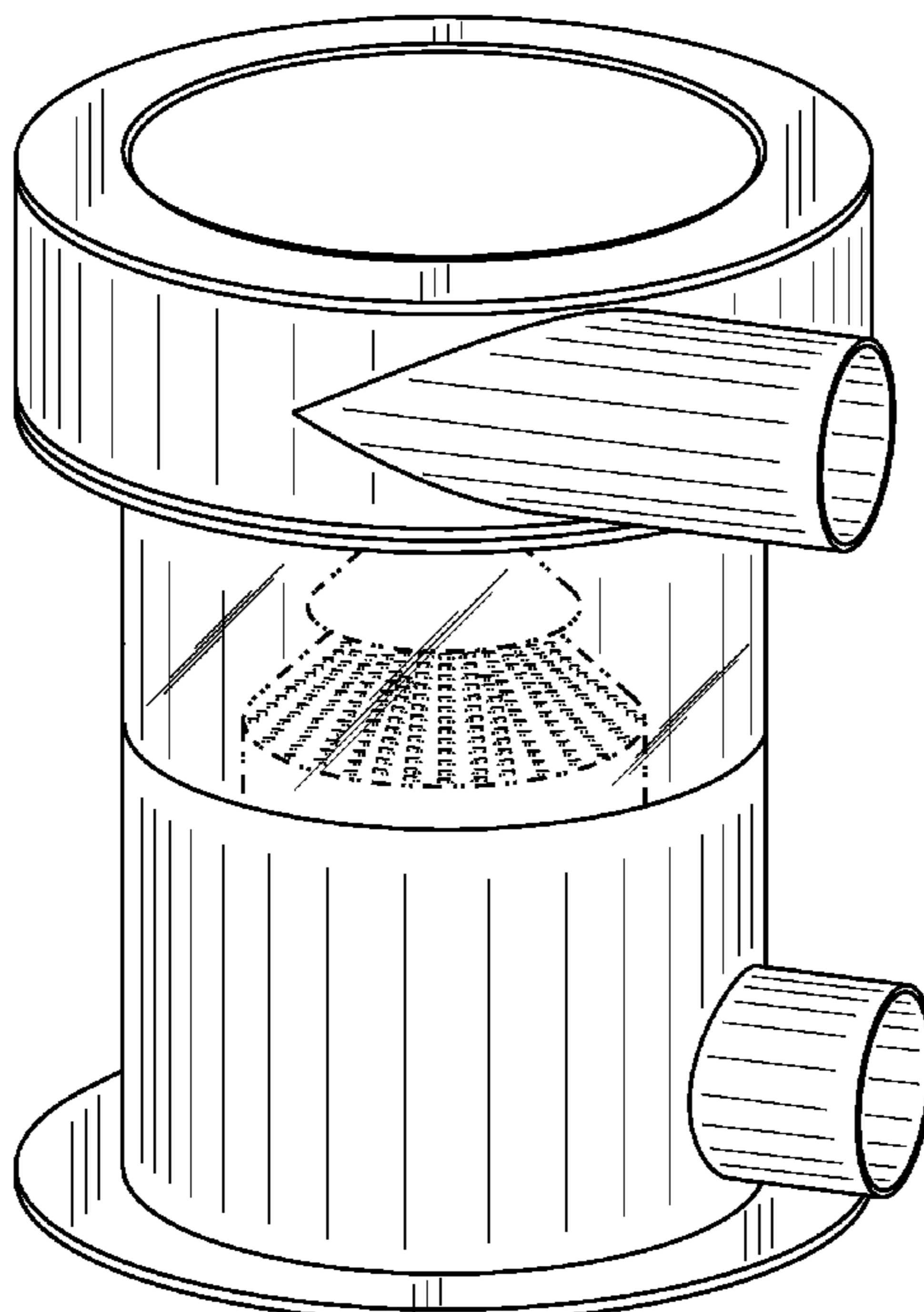

Fig. 1

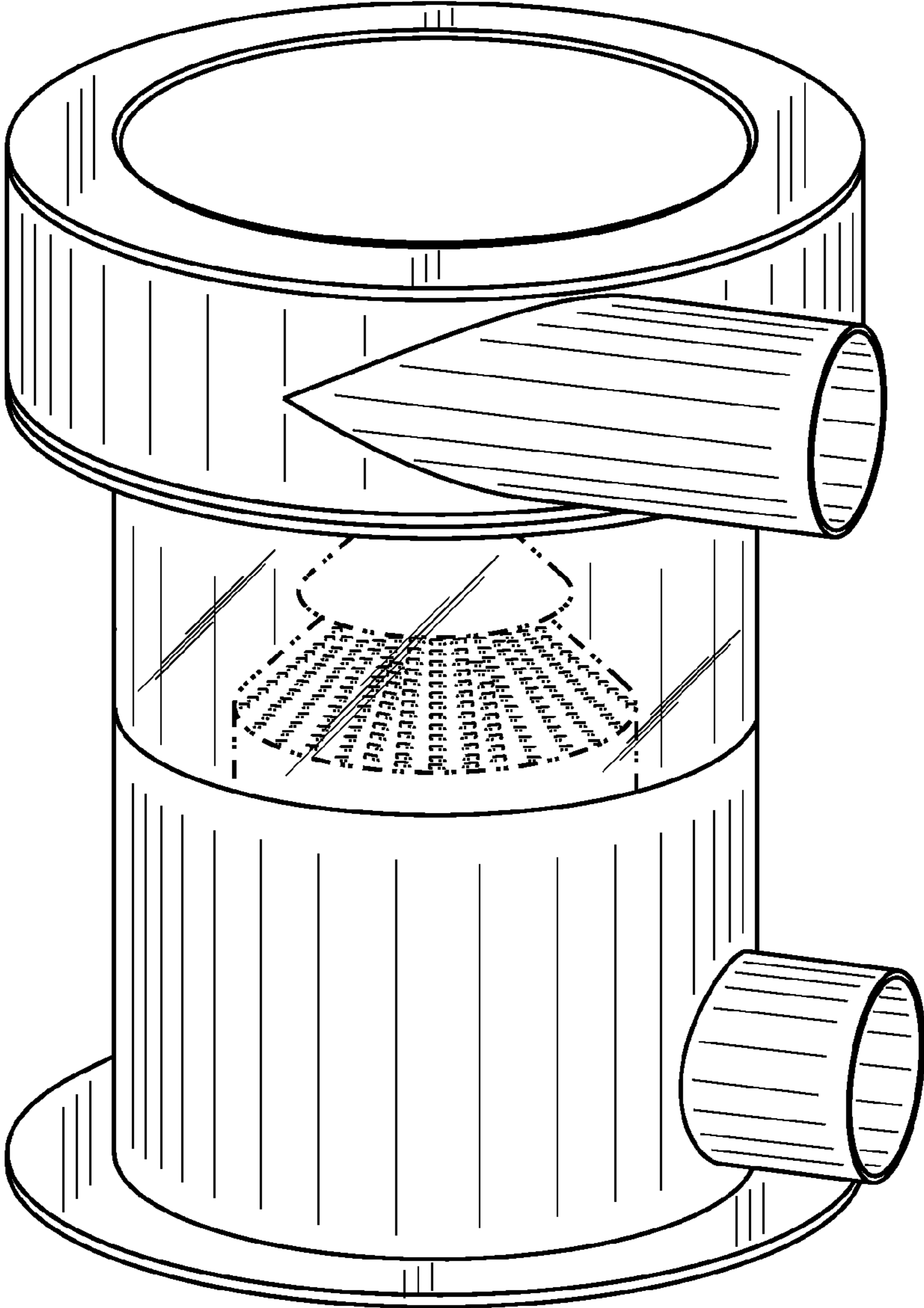

Fig. 2

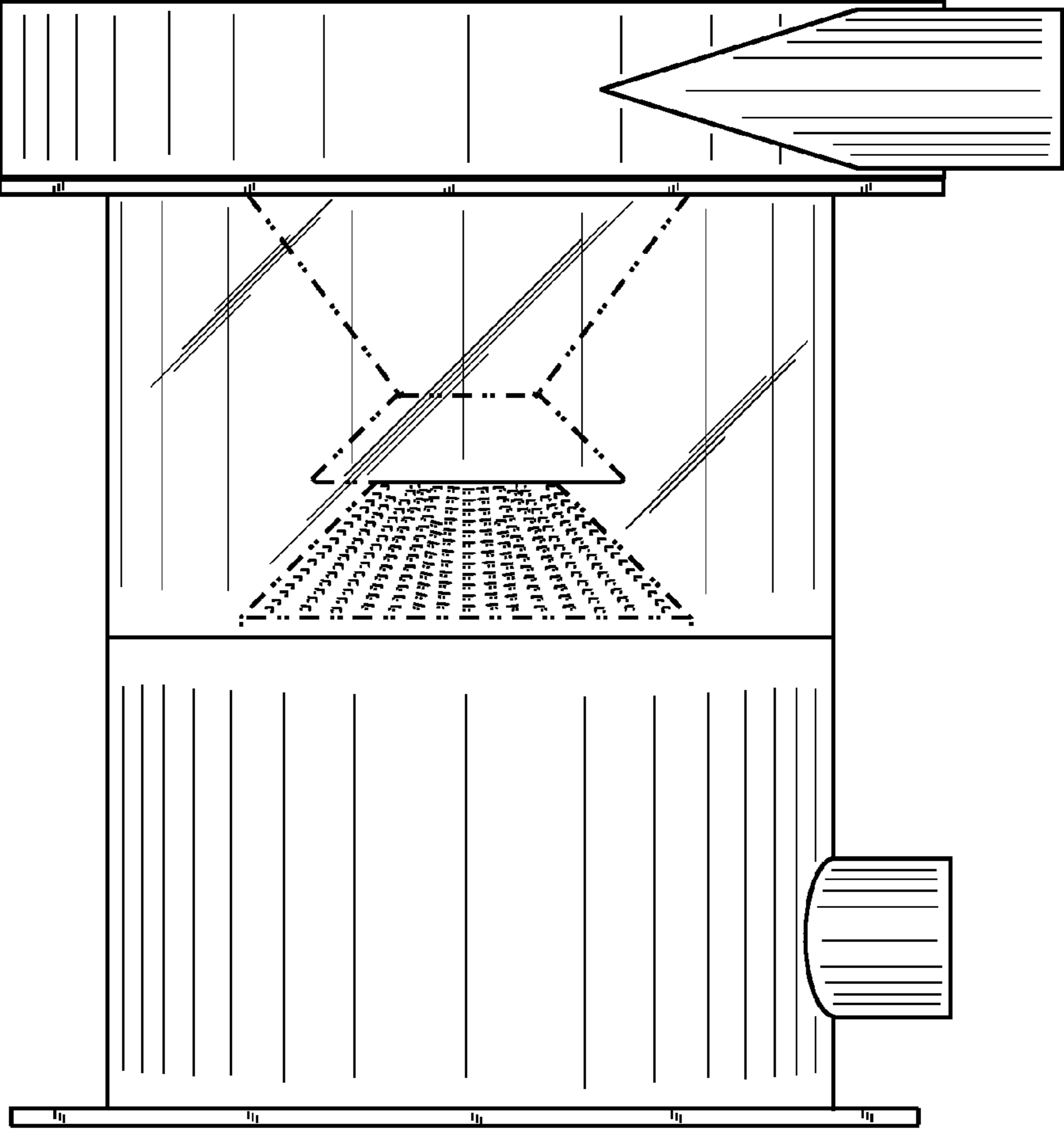

Fig. 3

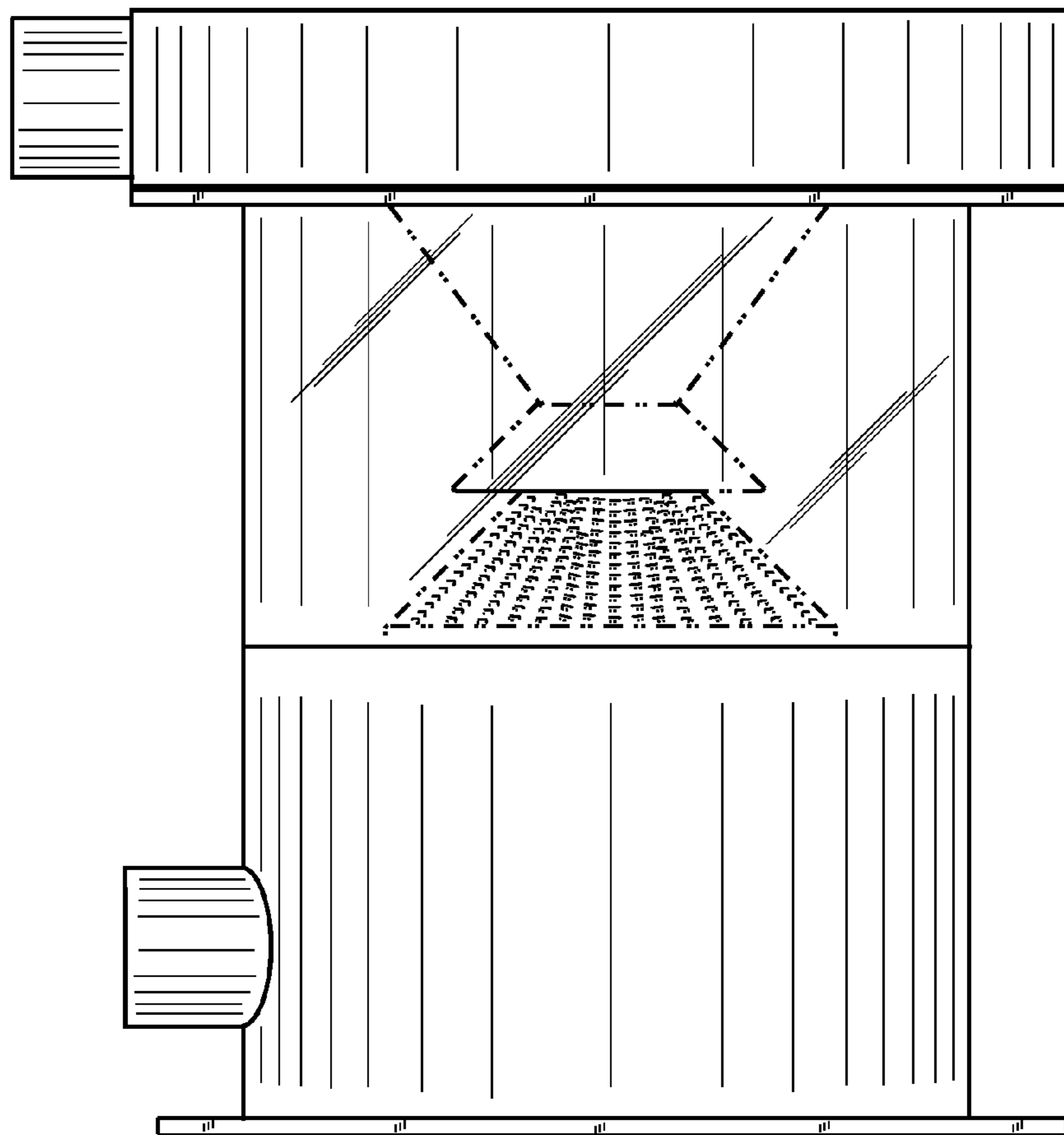

Fig. 4

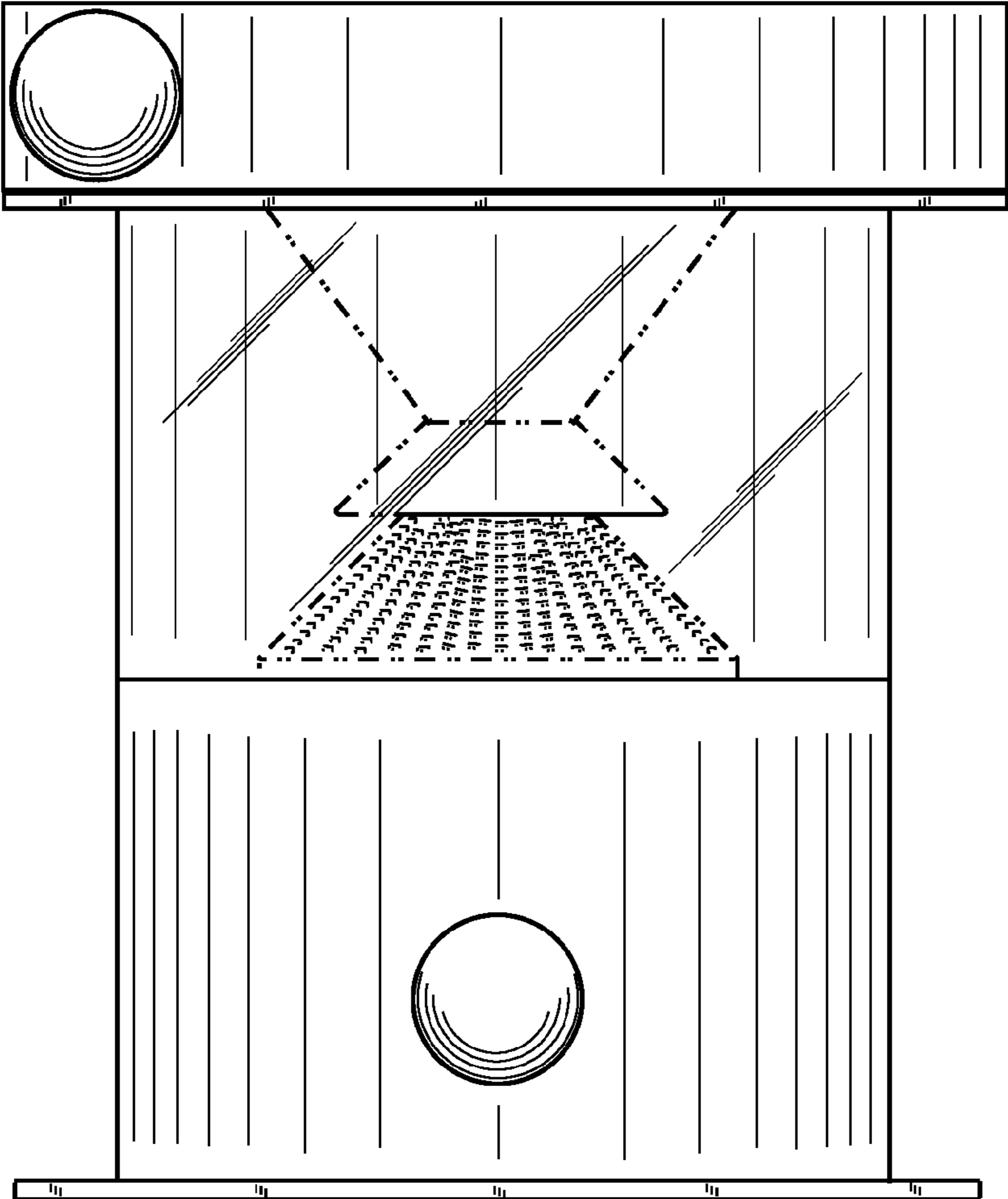

Fig. 5

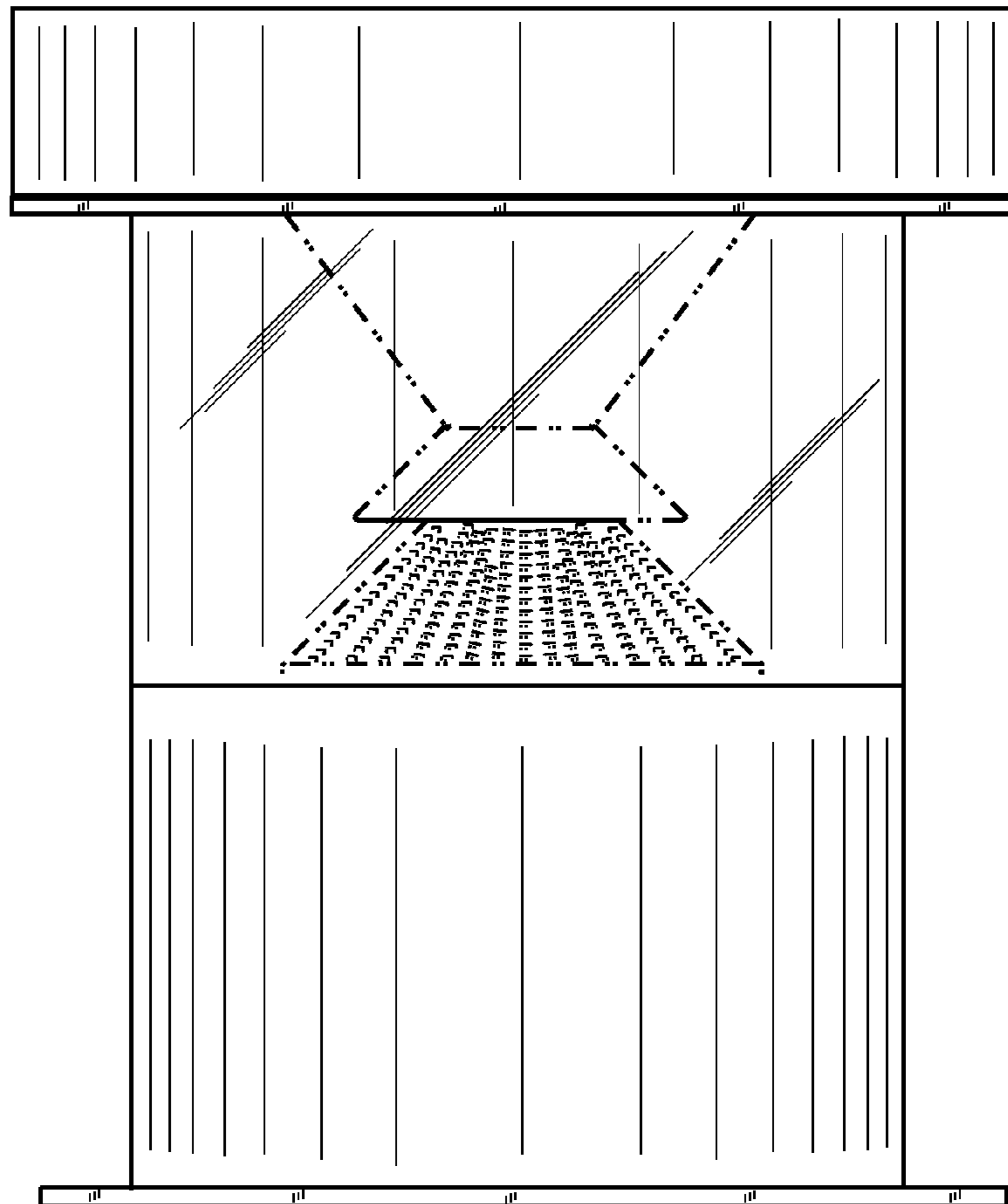

Fig. 6

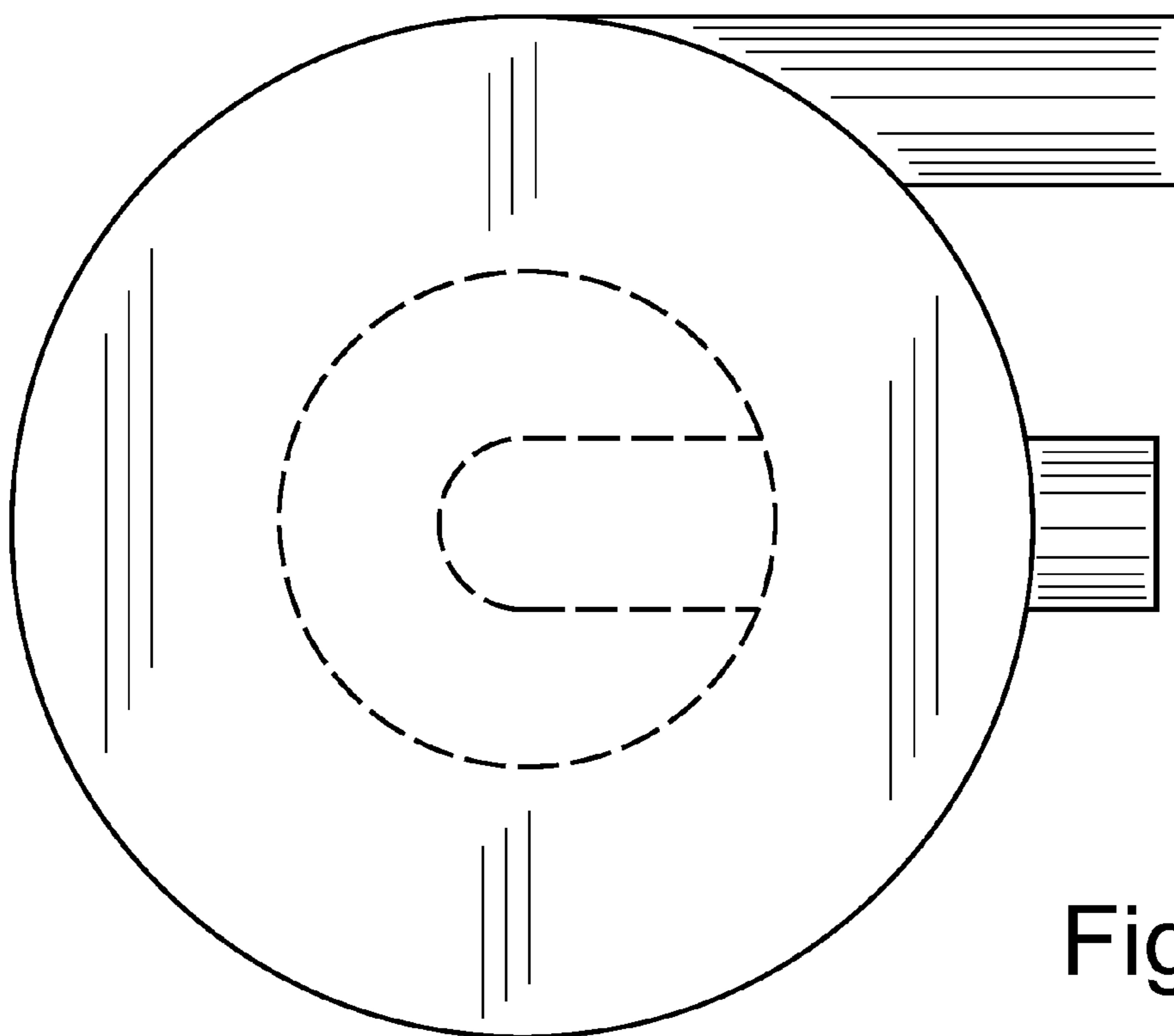
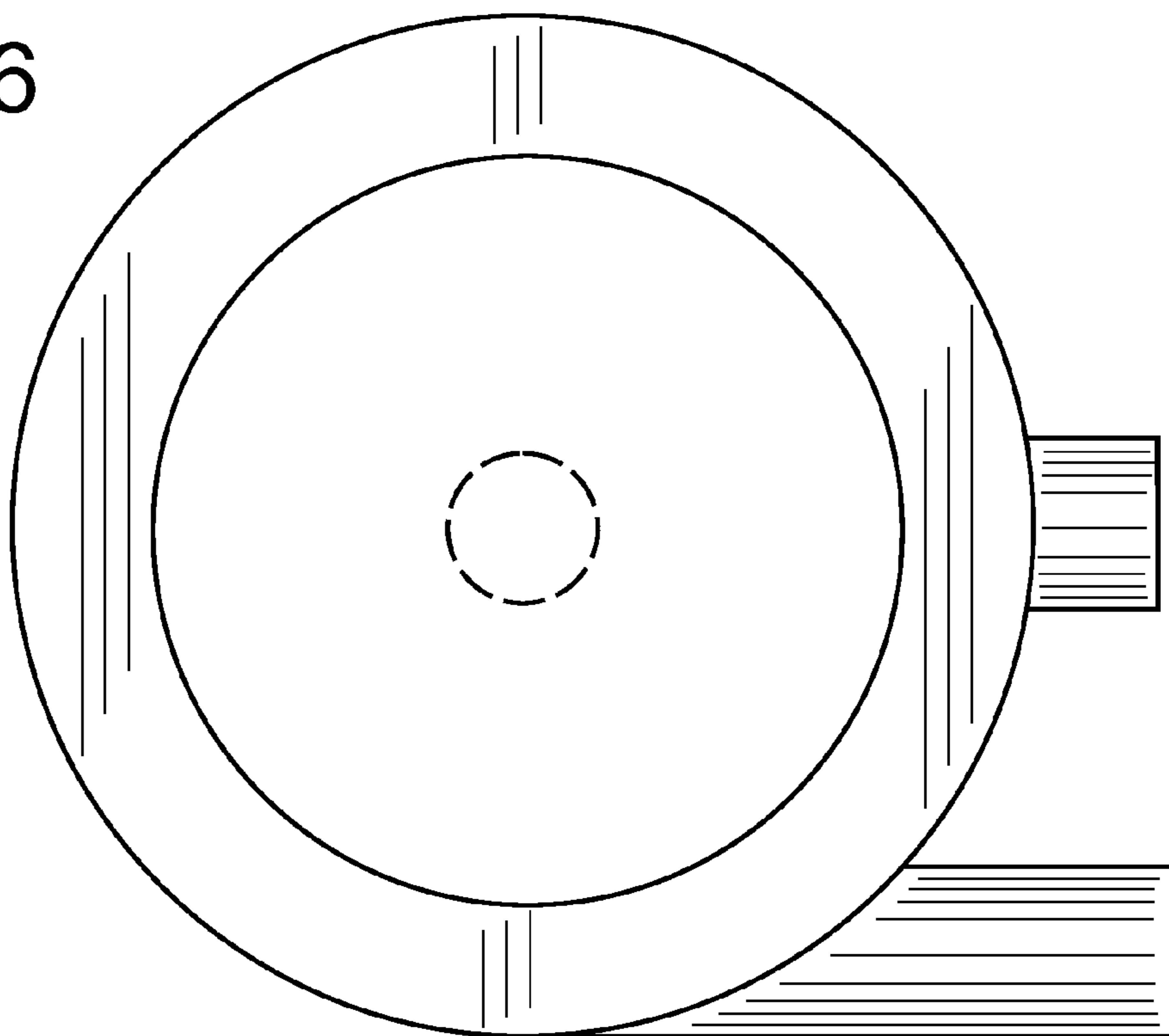

Fig. 7