



US00D658542S

(12) **United States Design Patent**
Eccles

(10) **Patent No.:** **US D658,542 S**
(45) **Date of Patent:** **** May 1, 2012**

(54) **ARROW WINDOW ORNAMENT**

D595,629 S 7/2009 Blumish

* cited by examiner

(76) Inventor: **Bradley A. Eccles**, Washington, IL (US)

Primary Examiner — T. Chase Nelson

(**) Term: **14 Years**

Assistant Examiner — Michelle E Wilson

(21) Appl. No.: **29/351,867**

(74) *Attorney, Agent, or Firm* — QuickPatents, Inc.; Kevin Prince

(22) Filed: **Dec. 11, 2009**

(51) **LOC (9) Cl.** **11-99**

(52) **U.S. Cl.** **D11/184**

(58) **Field of Classification Search** D12/190,
D12/400, 90, 92, 199, 197, 86, 171, 169,
D12/163, 110, 114, 198, 218, 201; D11/211,
D11/81, 157, 133, 172; D21/584, 591, 611,
D21/612; 293/102, 115; D20/11, 23, 25;
40/413, 591-592; 428/98-99, 31
See application file for complete search history.

(57) **CLAIM**

What is claimed is the ornamental design for a arrow window ornament, as shown and described.

DESCRIPTION

FIG. 1 is a perspective view of the arrow window ornament of the new design;
FIG. 2 is a front elevational view thereof;
FIG. 3 is a rear elevational view thereof;
FIG. 4 is a right-side elevational view thereof, the left-side elevational view being a mirror image thereof;
FIG. 5 is a top plan view thereof; and,
FIG. 6 is a bottom plan view thereof.

The broken lines showing a car window in FIG. 1 are included for the purpose of illustrating the invention in use, and form no part of the claimed design. The side, top and bottom views of the second embodiment are identical to those of the first embodiment.

The broken line circle and area within it in FIG. 2 depicts a portion of the novelty arrow window ornament that forms no part of the claimed design.

The broken line showing of a car window is included for the purpose of illustrating environment and forms no part of the claimed design.

(56) **References Cited**

U.S. PATENT DOCUMENTS

2,292,523	A	8/1942	Hynek	
D160,030	S	9/1950	Strauss	
D260,623	S	9/1981	Gorski	
D344,699	S	3/1994	Stortz	
D388,832	S *	1/1998	Stiemert D20/11
D391,917	S	3/1998	Hicks, Jr.	
D411,484	S	6/1999	Hill	
D451,048	S	11/2001	Adams	
D469,394	S	1/2003	Greyslock	
D471,508	S *	3/2003	Schifrin D12/400
D505,898	S	6/2005	Marchese	
D506,226	S *	6/2005	Koval et al. D20/33
D569,775	S	5/2008	Huang	
D586,861	S	2/2009	Noble	
D587,314	S	2/2009	Carnation, III	

1 Claim, 2 Drawing Sheets

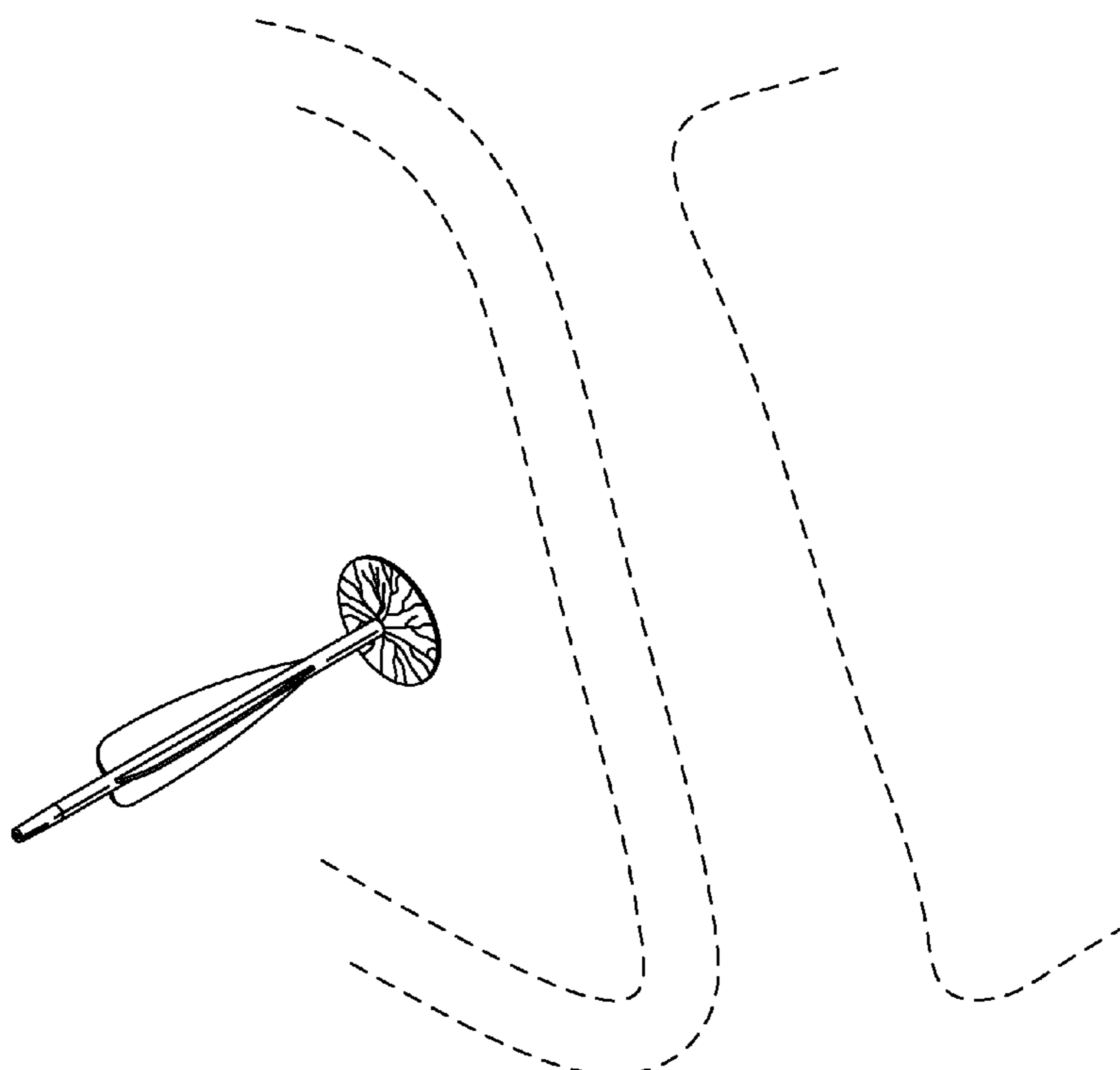

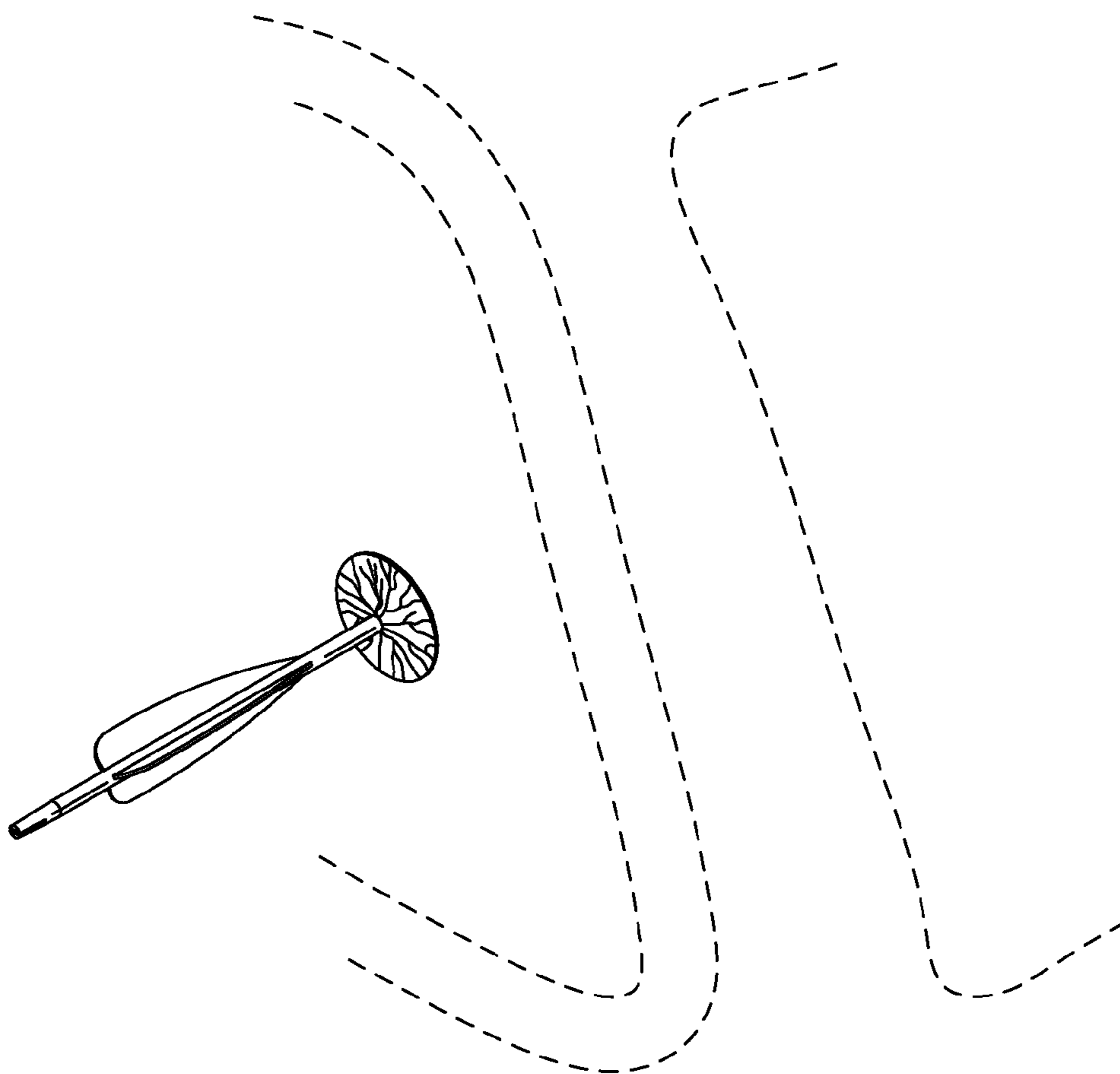

FIG. 1

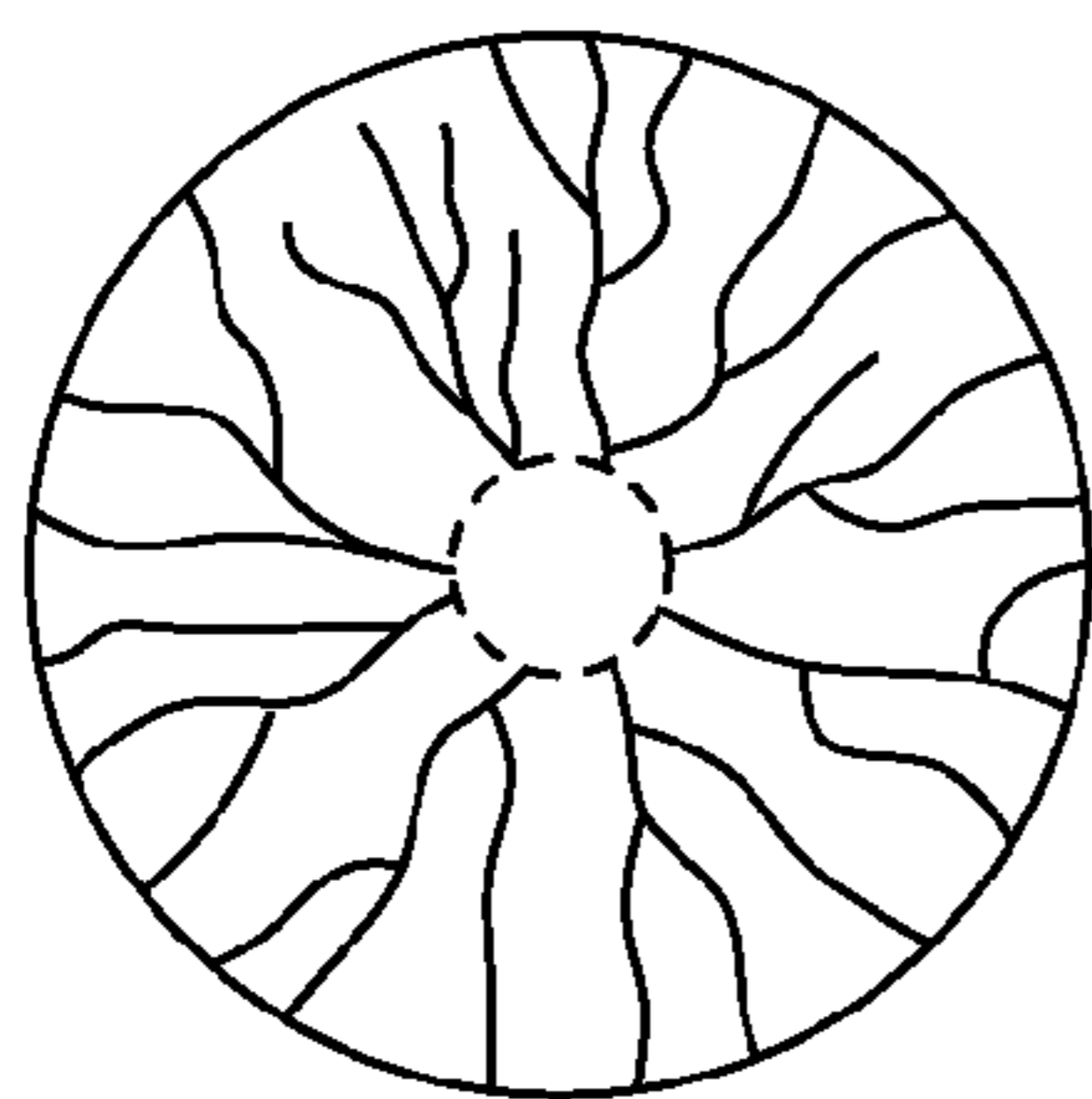

FIG. 2

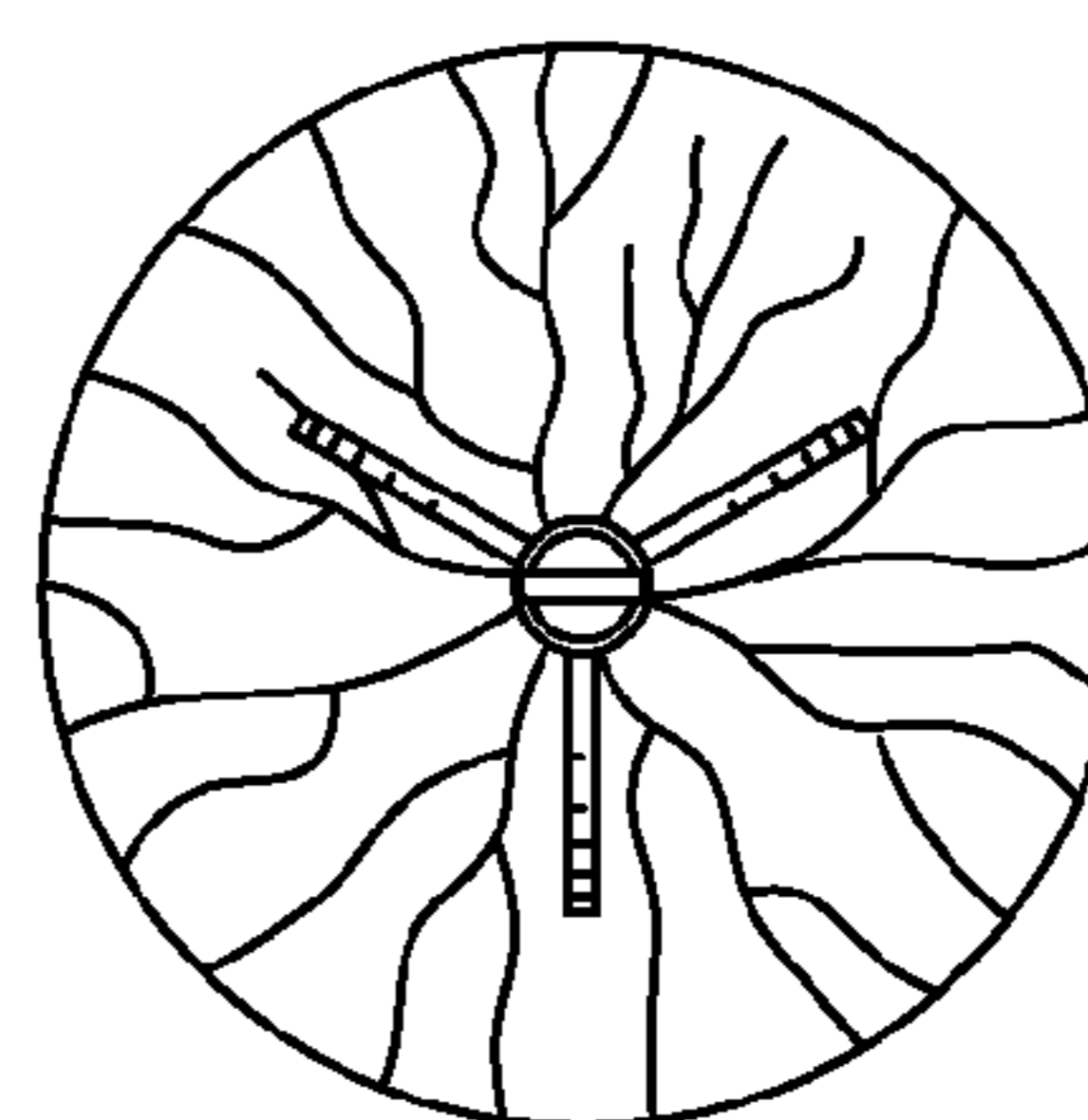

FIG. 3

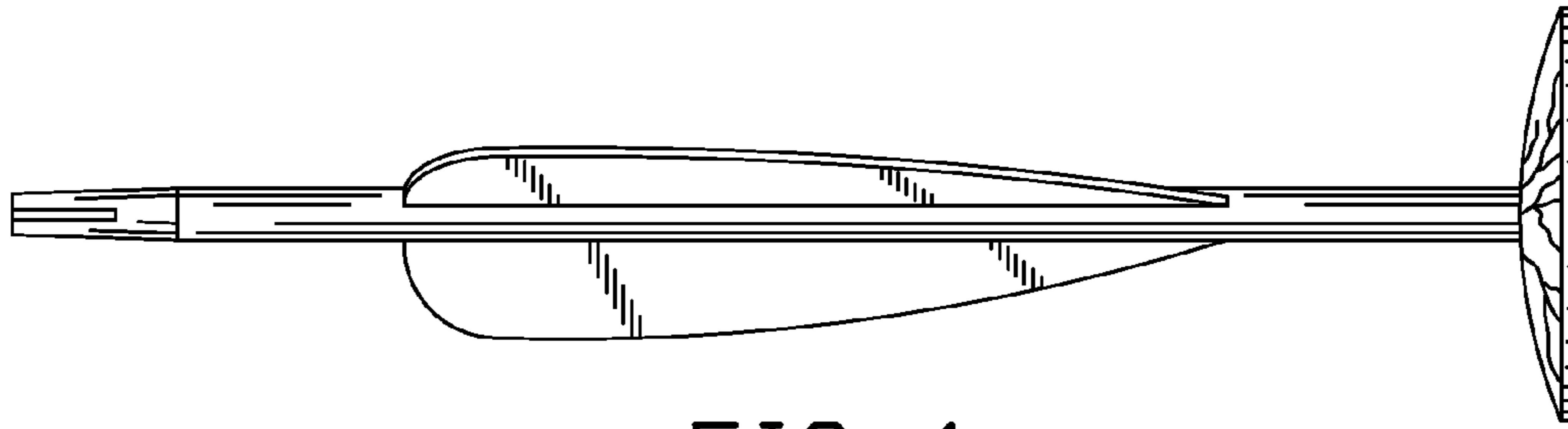

FIG. 4

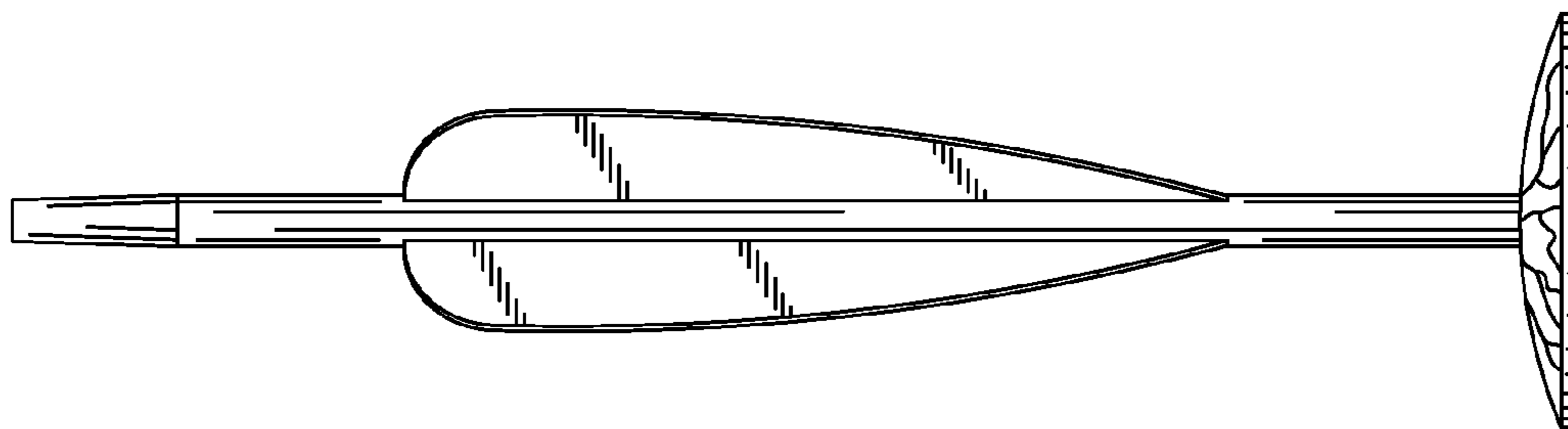

FIG. 5

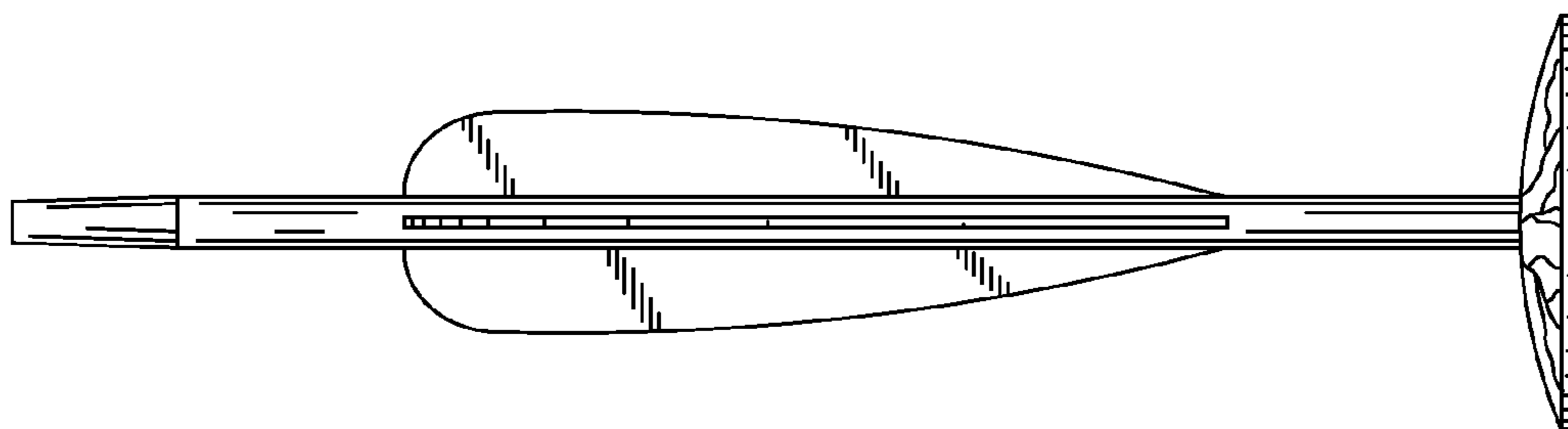

FIG. 6