

US00D658490S

(12) **United States Design Patent**  
**Lien**

(10) **Patent No.:** **US D658,490 S**

(45) **Date of Patent:** **\*\* May 1, 2012**

(54) **AFFIXING PIN FOR DRY WALL OR THE LIKE**

(76) Inventor: **Chin-Hsiung Lien**, El Monte, CA (US)

(\*\*) Term: **14 Years**

(21) Appl. No.: **29/372,669**

(22) Filed: **Dec. 23, 2010**

(51) **LOC (9) Cl.** ..... **08-08**

(52) **U.S. Cl.** ..... **D8/388; D8/391**

(58) **Field of Classification Search** ..... D8/388,  
D8/389, 391, 393; D19/65, 90; 411/473,  
411/401, 439, 480-488, 500, 489; 24/706,  
24/711.4

See application file for complete search history.

(56) **References Cited**

**U.S. PATENT DOCUMENTS**

412,728	A *	10/1889	Carstens	.....	168/38
417,066	A *	12/1889	Miner	.....	411/489
1,276,544	A *	8/1918	Knight	.....	411/489
D136,735	S *	11/1943	Lester	.....	D8/393
D149,901	S *	6/1948	Olsen	.....	D8/14
3,209,422	A *	10/1965	Dritz	.....	24/706
3,386,328	A *	6/1968	Litfin	.....	411/485
D407,012	S *	3/1999	Williams	.....	D8/388
D409,663	S *	5/1999	Wagner et al.	.....	D19/65
D410,032	S *	5/1999	Wagner et al.	.....	D19/65
D412,434	S *	8/1999	Cook	.....	D8/388
D414,207	S *	9/1999	Wagner et al.	.....	D19/65
5,988,967	A *	11/1999	Jones	.....	411/489
D428,058	S *	7/2000	Wagner	.....	D19/65

6,132,060	A *	10/2000	Gallo	.....	362/190
6,371,706	B1 *	4/2002	Wallace	.....	411/30
D483,253	S *	12/2003	Sayegh et al.	.....	D8/388
D507,306	S *	7/2005	Siegel	.....	D19/90
D508,533	S *	8/2005	Siegel	.....	D19/90
D531,223	S *	10/2006	Lynch	.....	D19/65
D534,061	S *	12/2006	Sakai	.....	D8/373
D629,293	S *	12/2010	DuFour	.....	D8/388
D629,678	S *	12/2010	Norton et al.	.....	D8/388

\* cited by examiner

*Primary Examiner* — Cynthia M Chin

*Assistant Examiner* — Sheryl Lane

(74) *Attorney, Agent, or Firm* — Raymond Y. Chan; David and Raymond Patent Firm

(57) **CLAIM**

The ornamental design for an affixing pin for dry wall or the like, as shown and described.

**DESCRIPTION**

FIG. 1 is a perspective view of affixing pin for drywall or the like showing my new design.

FIG. 2 is a front view thereof.

FIG. 3 is a rear view thereof.

FIG. 4 is a right view thereof.

FIG. 5 is a left view thereof; and,

FIG. 6 is a top perspective view thereof.

The broken line showing of the pin head is included for the purpose of illustrating portions of the article and forms no part of the claimed design.

**1 Claim, 6 Drawing Sheets**

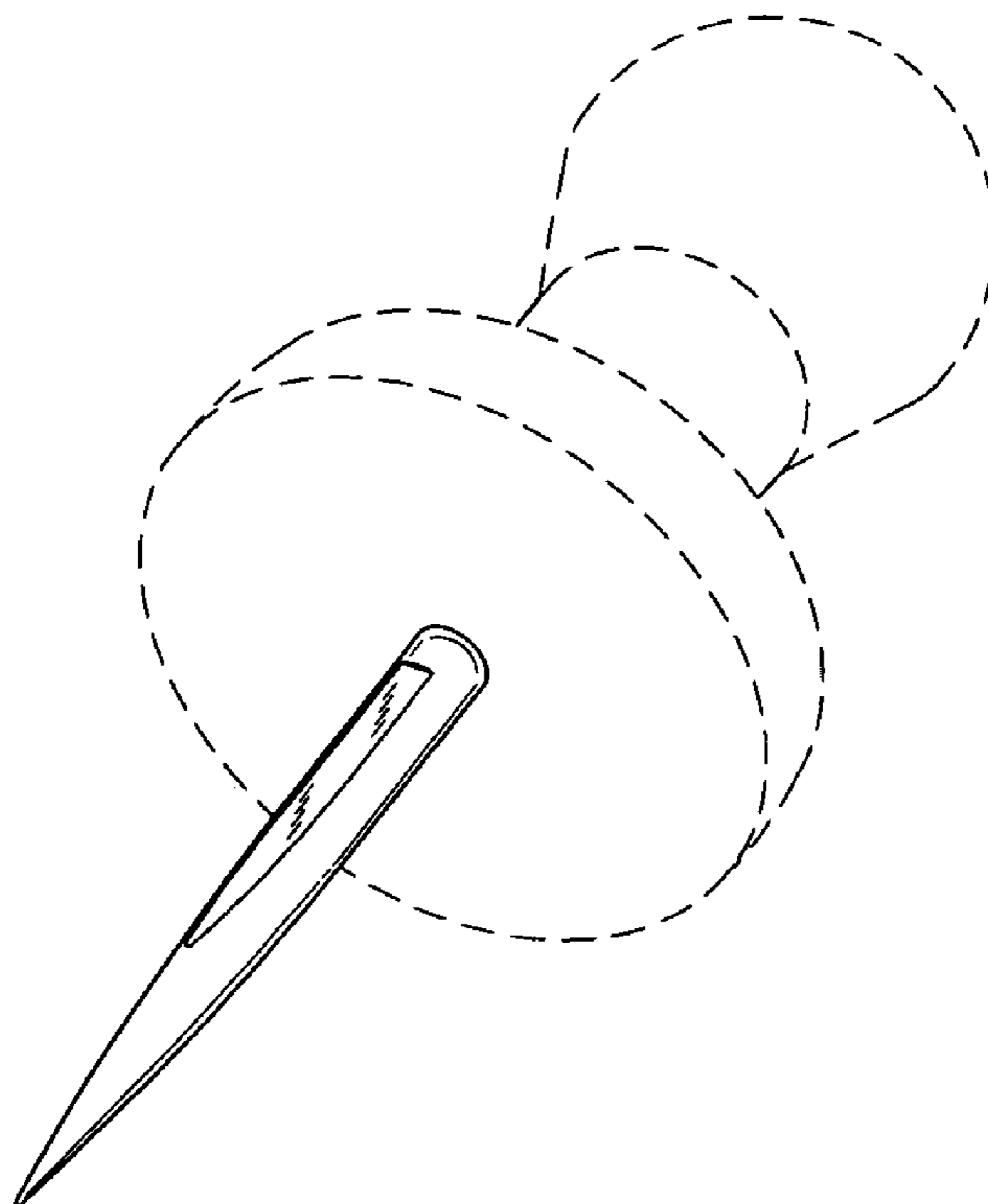

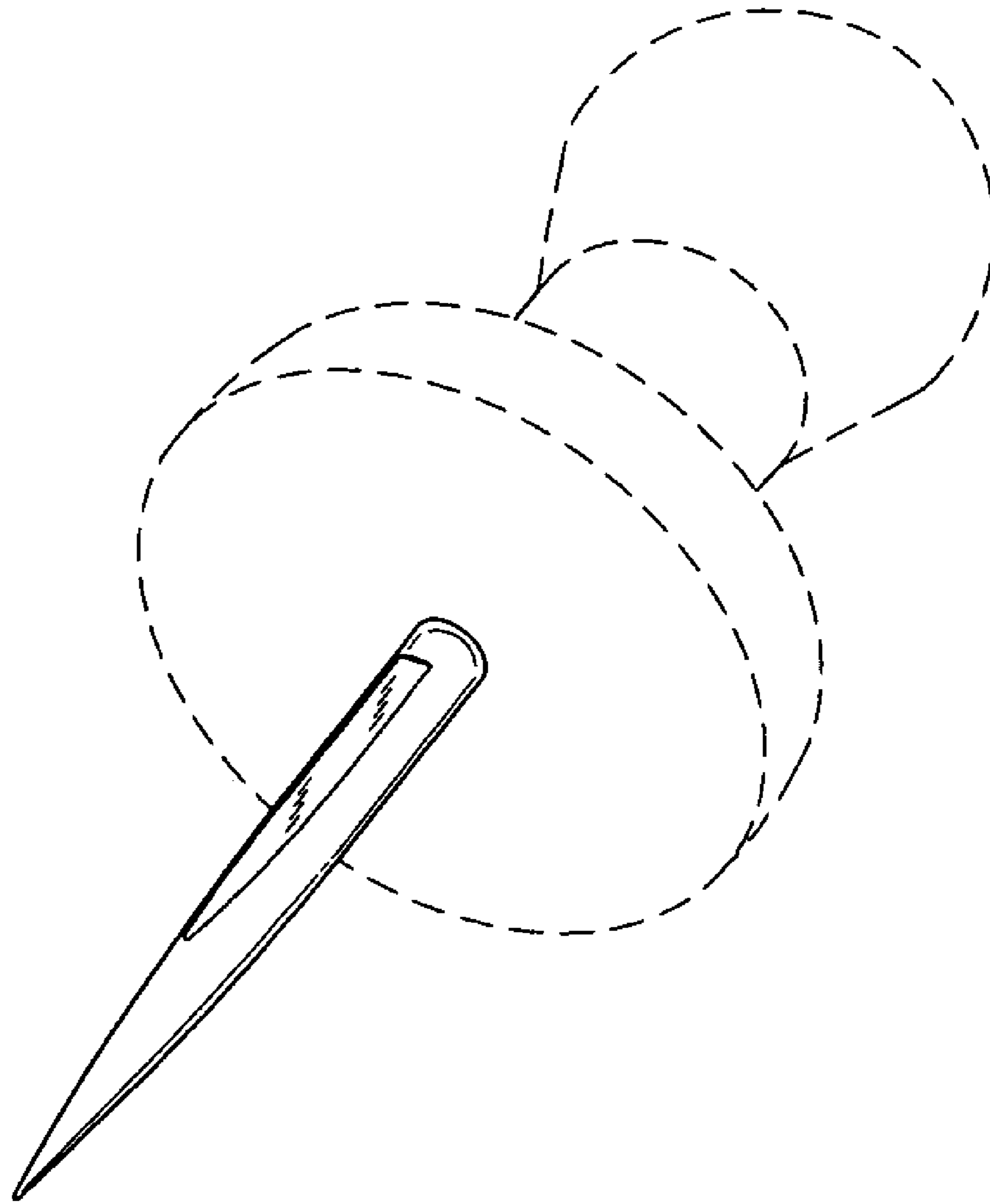

**FIG. 1**

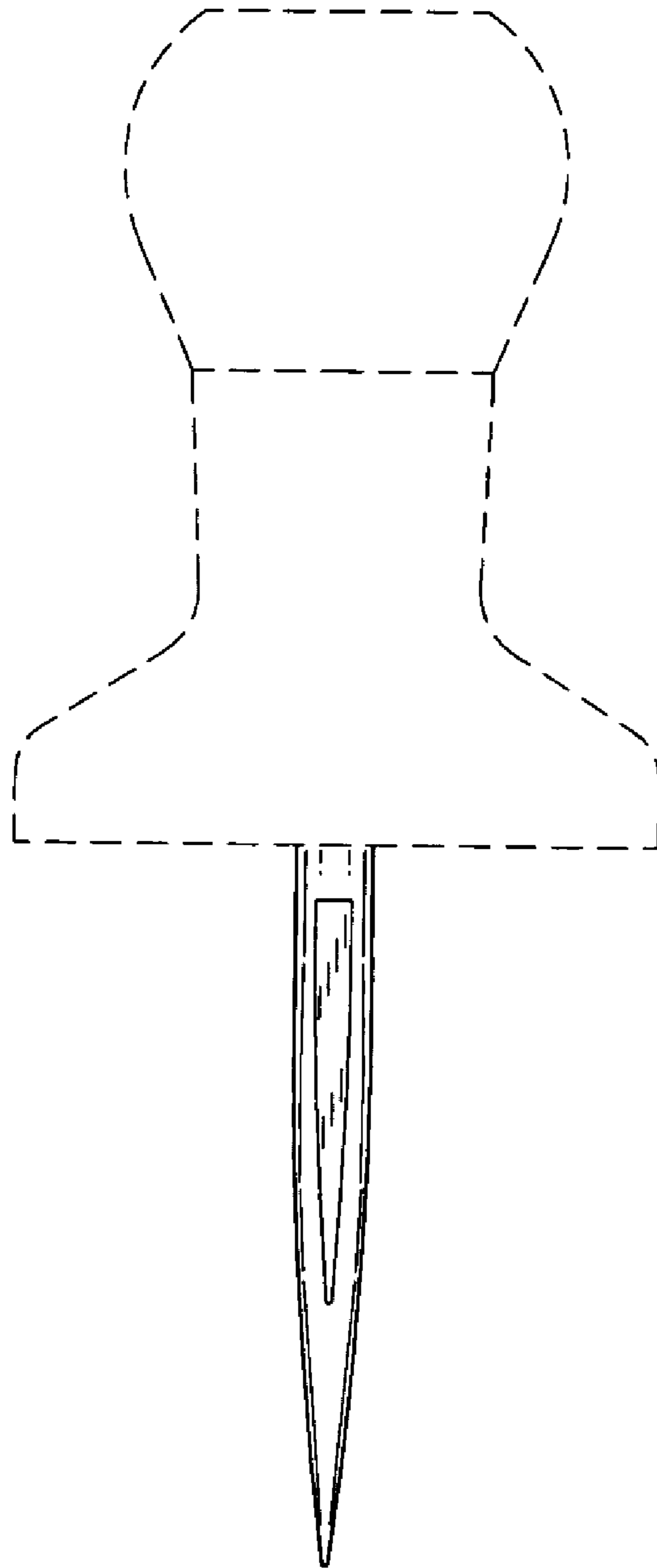

**FIG. 2**

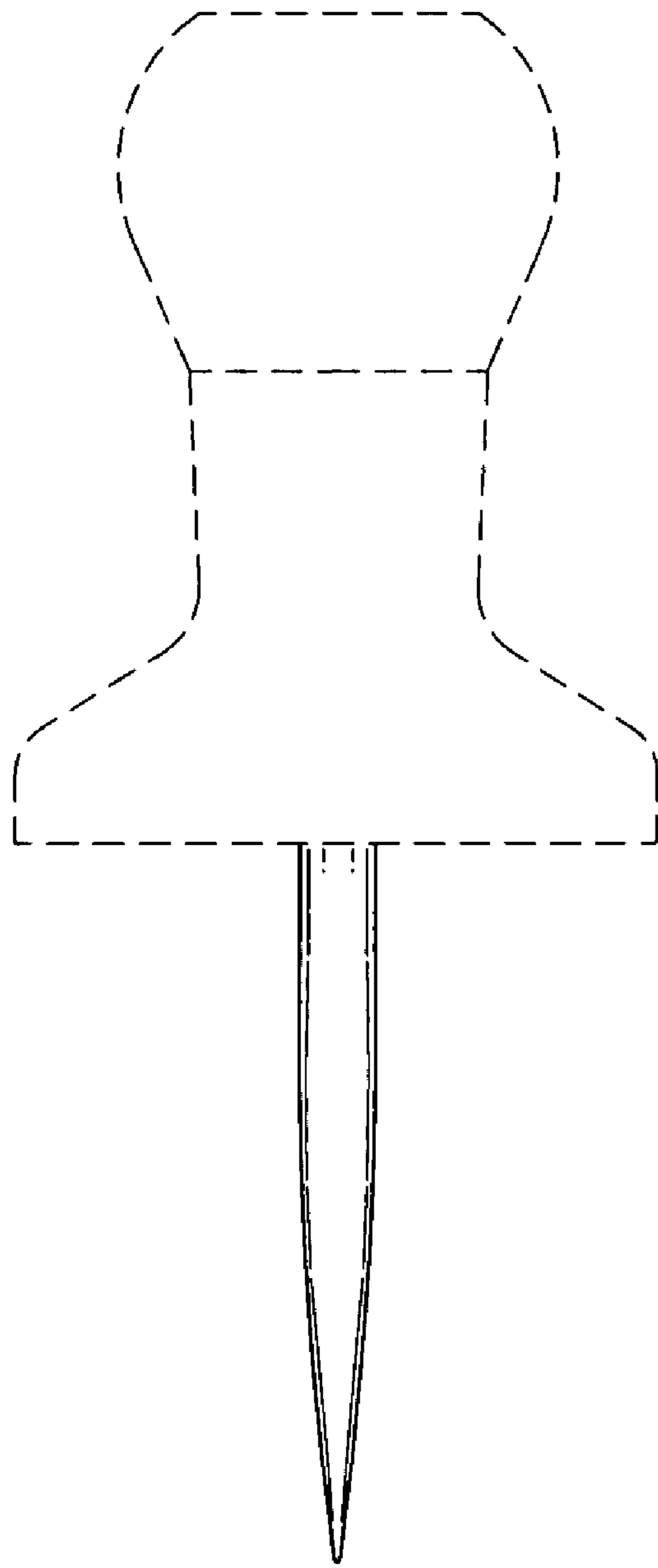

FIG. 3

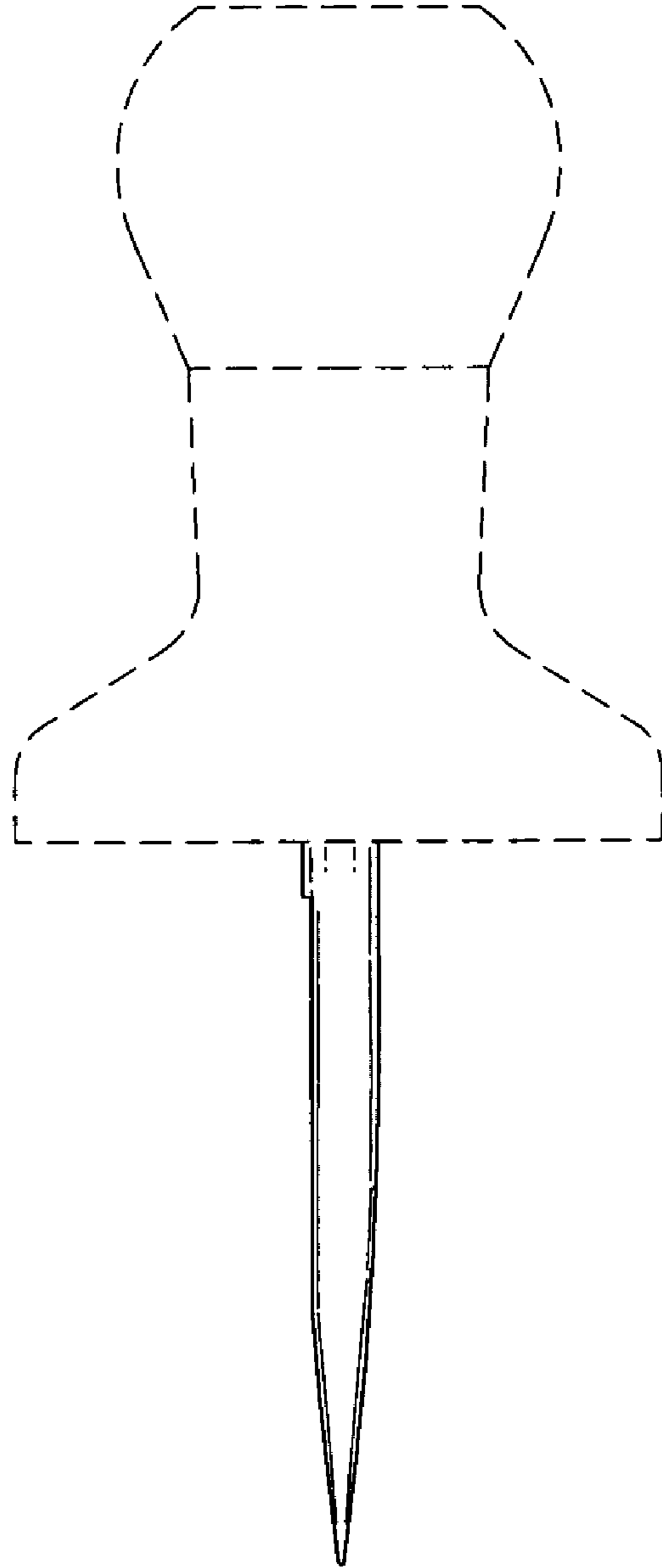

FIG. 4

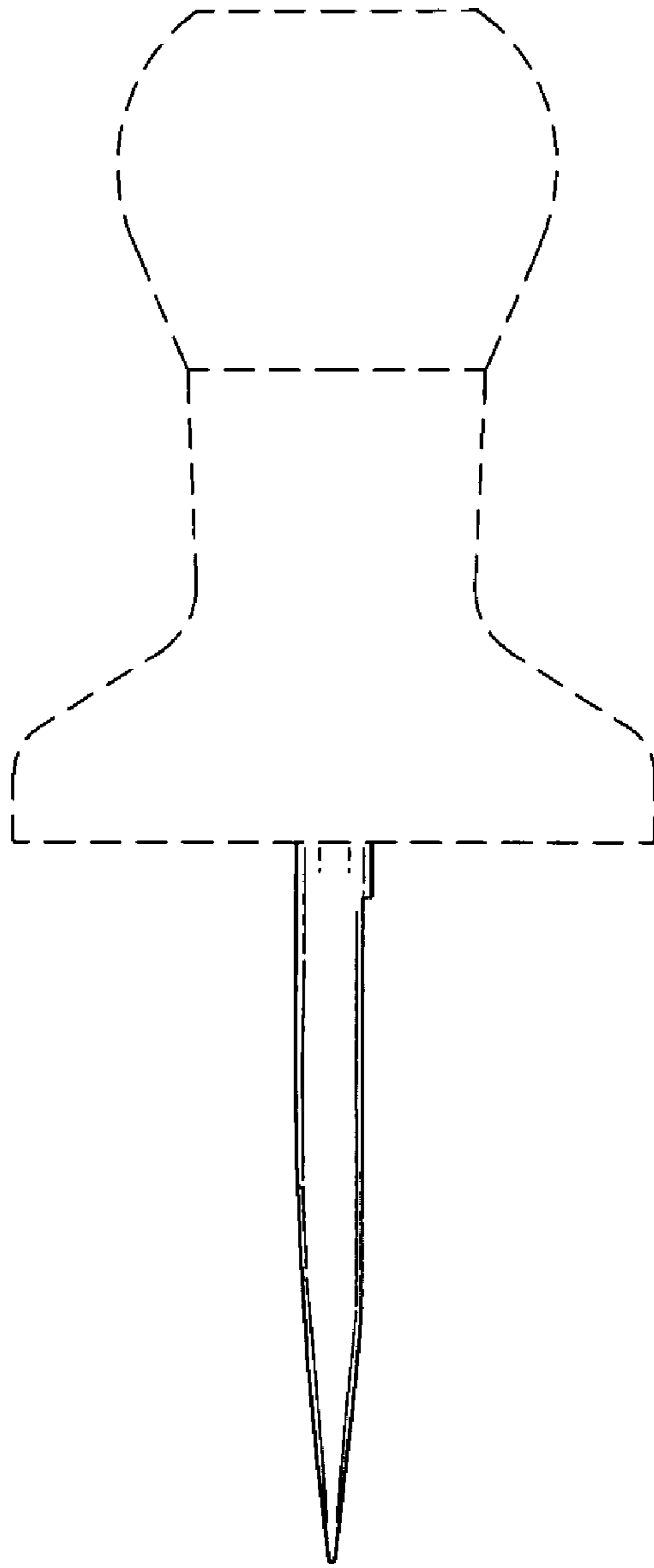
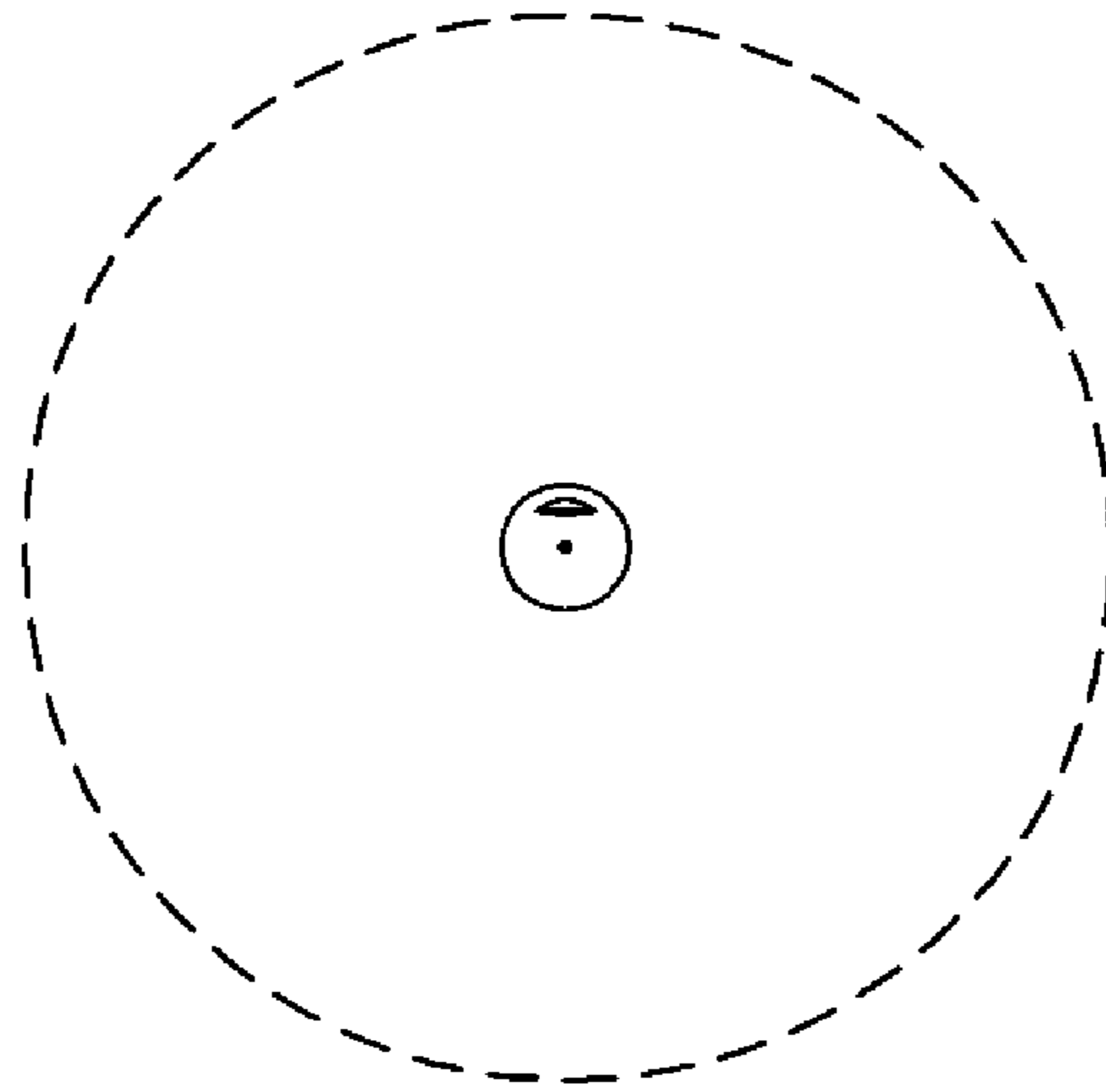

FIG. 5



**FIG. 6**