



US00D658053S

(12) **United States Design Patent**  
**Okun**

(10) **Patent No.:** **US D658,053 S**

(45) **Date of Patent:** **\*\* Apr. 24, 2012**

(54) **CONDUIT CLAMP**

(76) **Inventor:** **Douglas Okun**, Cambridge, MA (US)

(\*\*) **Term:** **14 Years**

(21) **Appl. No.:** **29/399,328**

(22) **Filed:** **Aug. 12, 2011**

(51) **LOC (9) Cl.** ..... **08-08**

(52) **U.S. Cl.** ..... **D8/396**

(58) **Field of Classification Search** ..... D8/354,  
D8/356, 371, 394-396; D19/65, 86; D24/128;  
248/74.1-74.2, 215, 227.1, 49, 300, 301,  
248/316.7, 51; 24/570, 3.12; D3/203.2,  
D3/203.3; D21/392

See application file for complete search history.

(56) **References Cited**

U.S. PATENT DOCUMENTS

1,853,402	A *	4/1932	Braly	.....	248/74.2
2,166,916	A *	7/1939	Lombard	.....	248/73
2,721,050	A *	10/1955	Sams	.....	248/62
D263,332	S *	3/1982	Butterfield	.....	D8/396
4,501,400	A *	2/1985	Leonardo	.....	248/74.1
5,108,055	A *	4/1992	Kreinberg et al.	.....	248/71
5,533,696	A *	7/1996	Laughlin et al.	.....	248/74.2
5,704,573	A *	1/1998	de Beers et al.	.....	248/73
D414,404	S *	9/1999	van de Lande	.....	D8/396
6,460,813	B1 *	10/2002	Gretz	.....	248/62
6,464,182	B1 *	10/2002	Snyder	.....	248/71

6,584,654	B1 *	7/2003	Schaub	.....	24/279
6,634,606	B2 *	10/2003	Heath	.....	248/74.1
7,053,311	B2 *	5/2006	Santanda	.....	174/154
7,240,880	B2 *	7/2007	Benoit et al.	.....	248/65
D559,084	S *	1/2008	Foxx et al.	.....	D8/356
7,832,248	B2 *	11/2010	Heath	.....	72/379.2
D632,555	S *	2/2011	Sarkissian	.....	D8/396
D636,661	S *	4/2011	Marmas	.....	D8/395
2003/0200634	A1 *	10/2003	Hansen	.....	24/297
2011/0226913	A1 *	9/2011	Feige	.....	248/74.2

\* cited by examiner

*Primary Examiner* — John Windmuller

(74) *Attorney, Agent, or Firm* — Gary E. Lambert; David Connaughton, Jr.; Lambert and Associates

(57) **CLAIM**

The ornamental design for a conduit clamp, as shown and described.

**DESCRIPTION**

FIG. 1 is an isometric view of the conduit clamp, which embodies my design;

FIG. 2 is a front view of the conduit clamp;

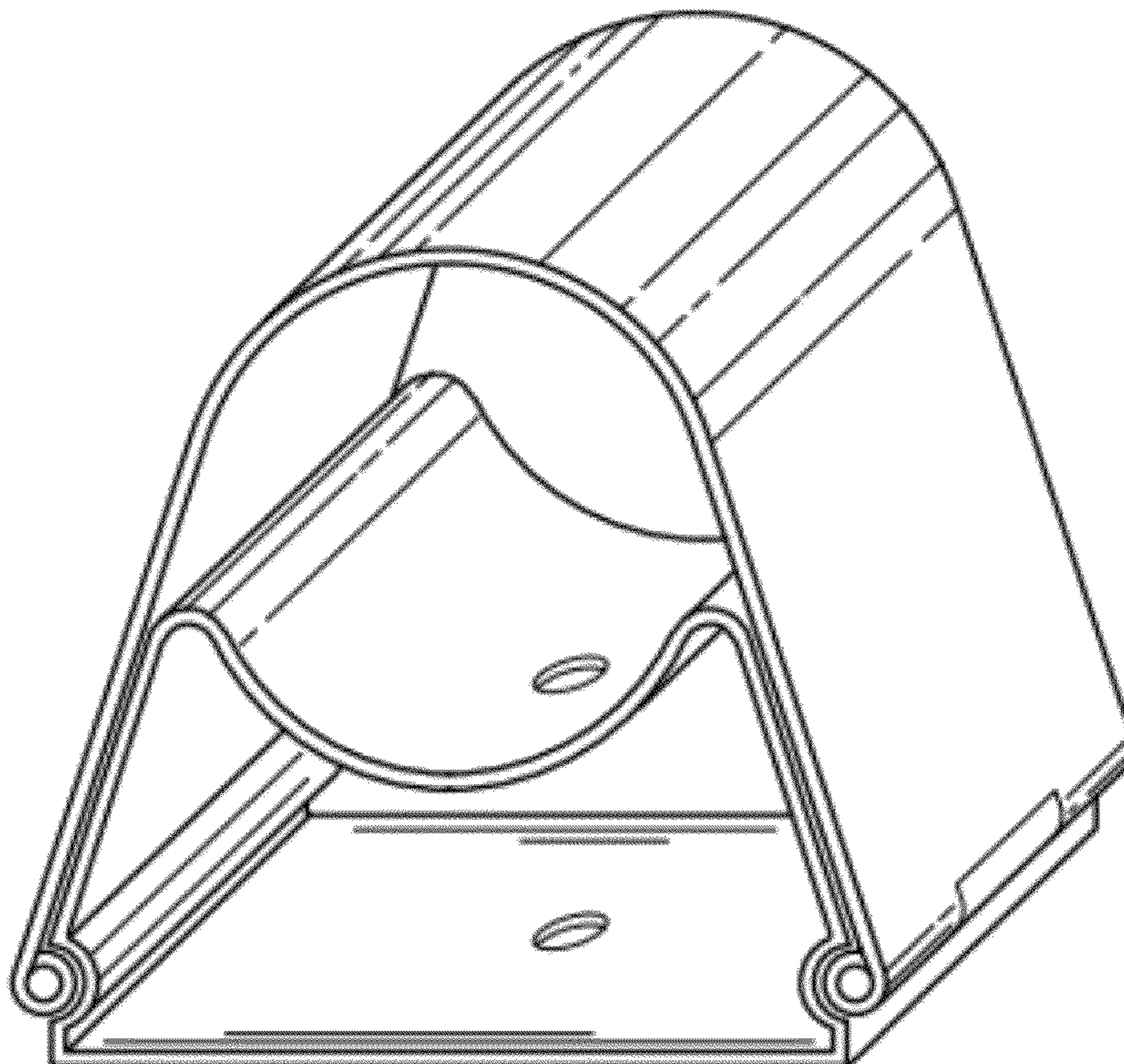
FIG. 3 is a side view of the conduit clamp;

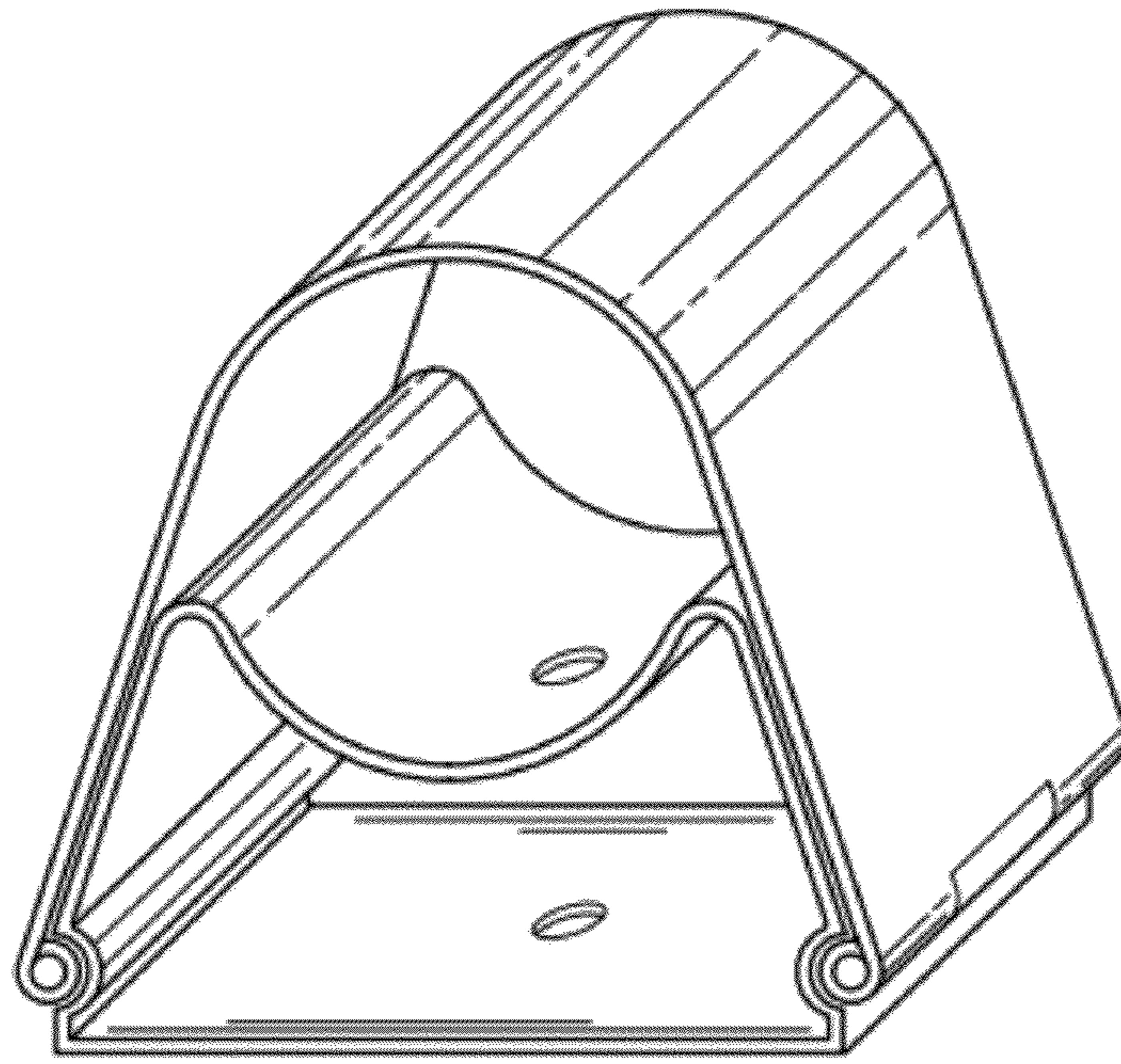
FIG. 4 is a top plane view of the conduit clamp;

FIG. 5 is a bottom plane view of the conduit clamp; and,

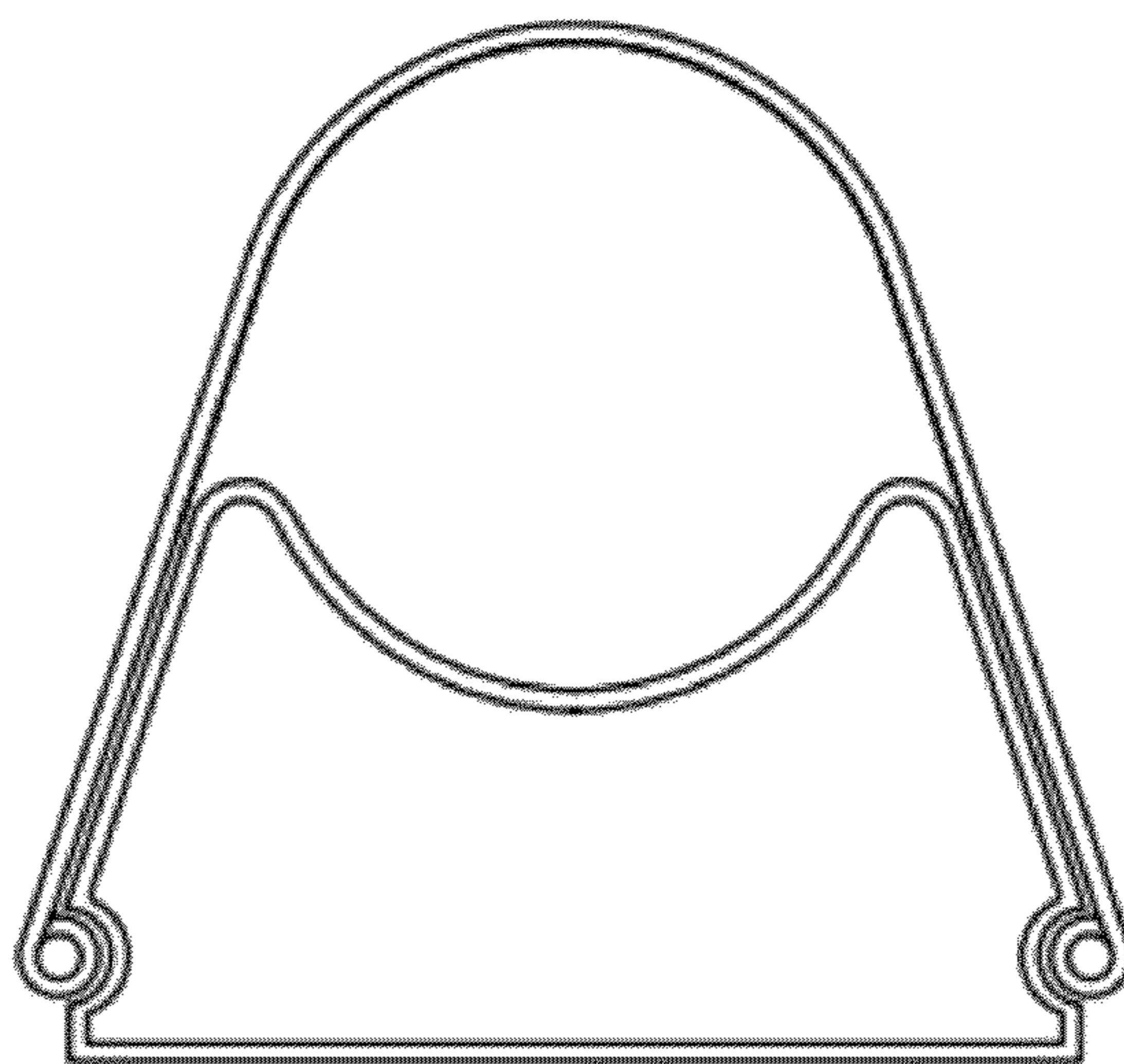
FIG. 6 is an illustrative view of a pipe showing my new design in a position of use. The broken line showing of the pipe in FIG. 6 is for illustrative purposes only and forms no part of the claimed design.

**1 Claim, 3 Drawing Sheets**



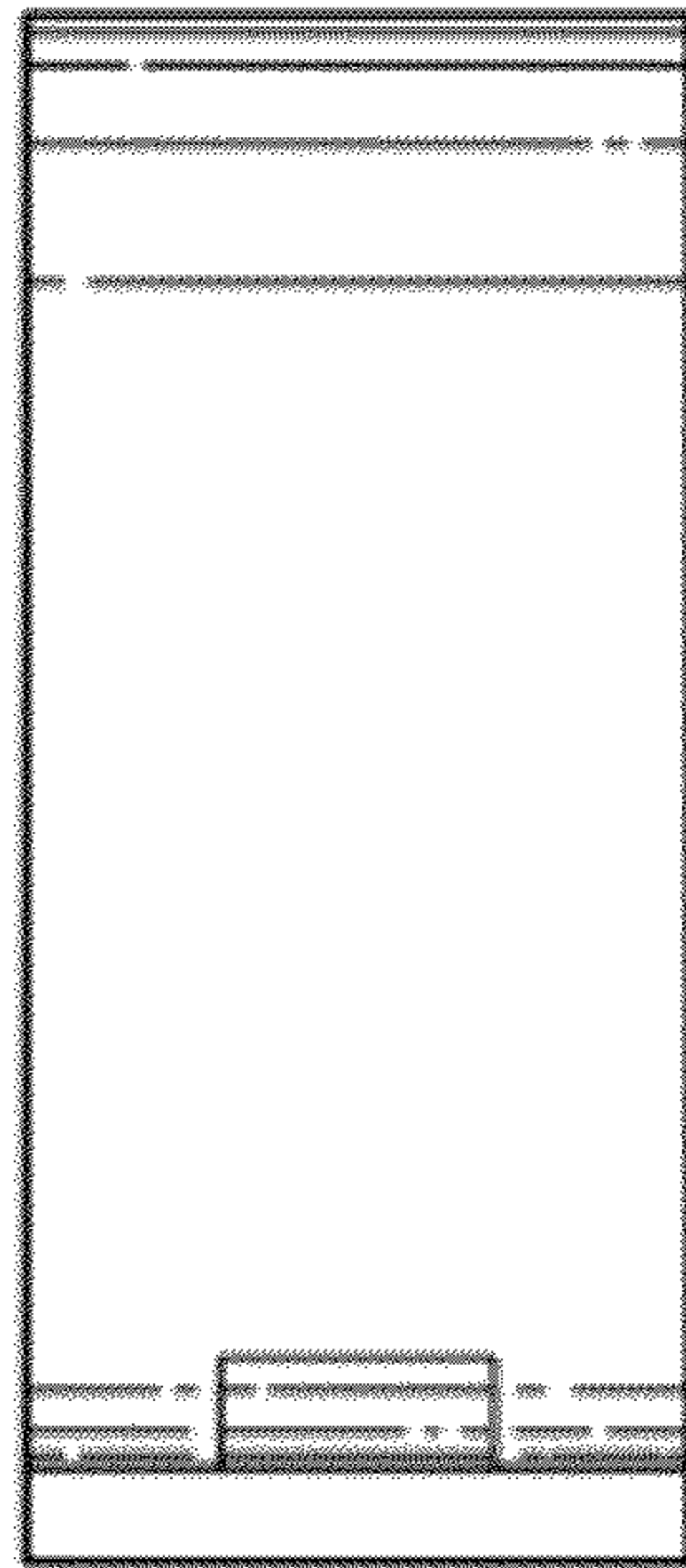


*Fig. 1*

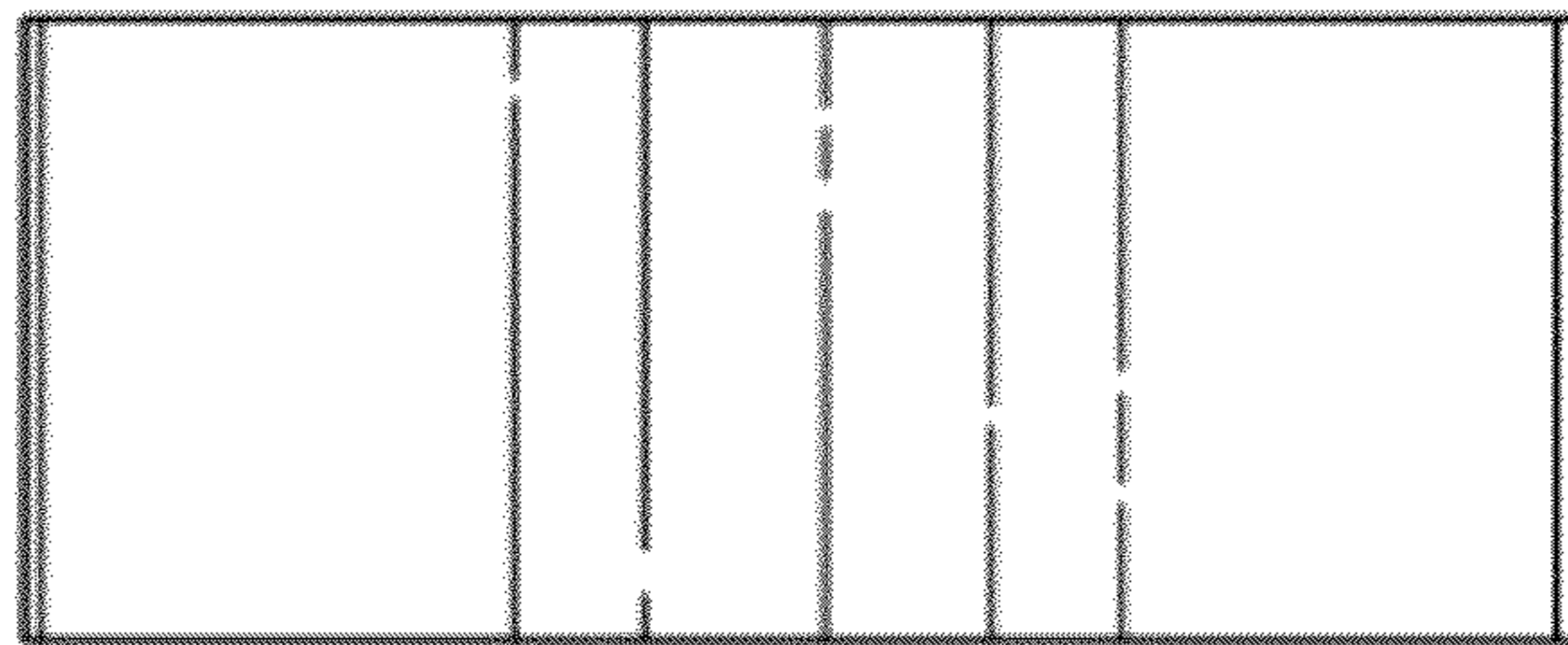


*Fig. 2*

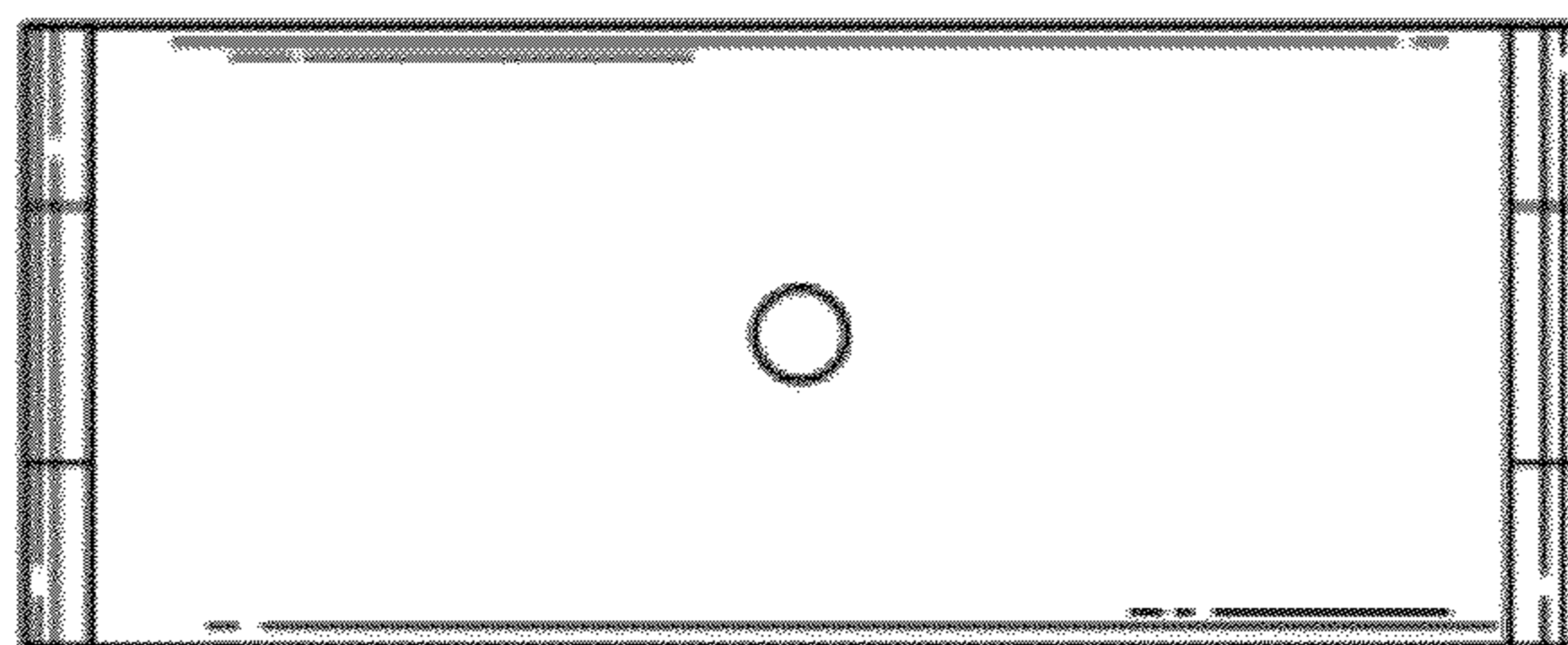




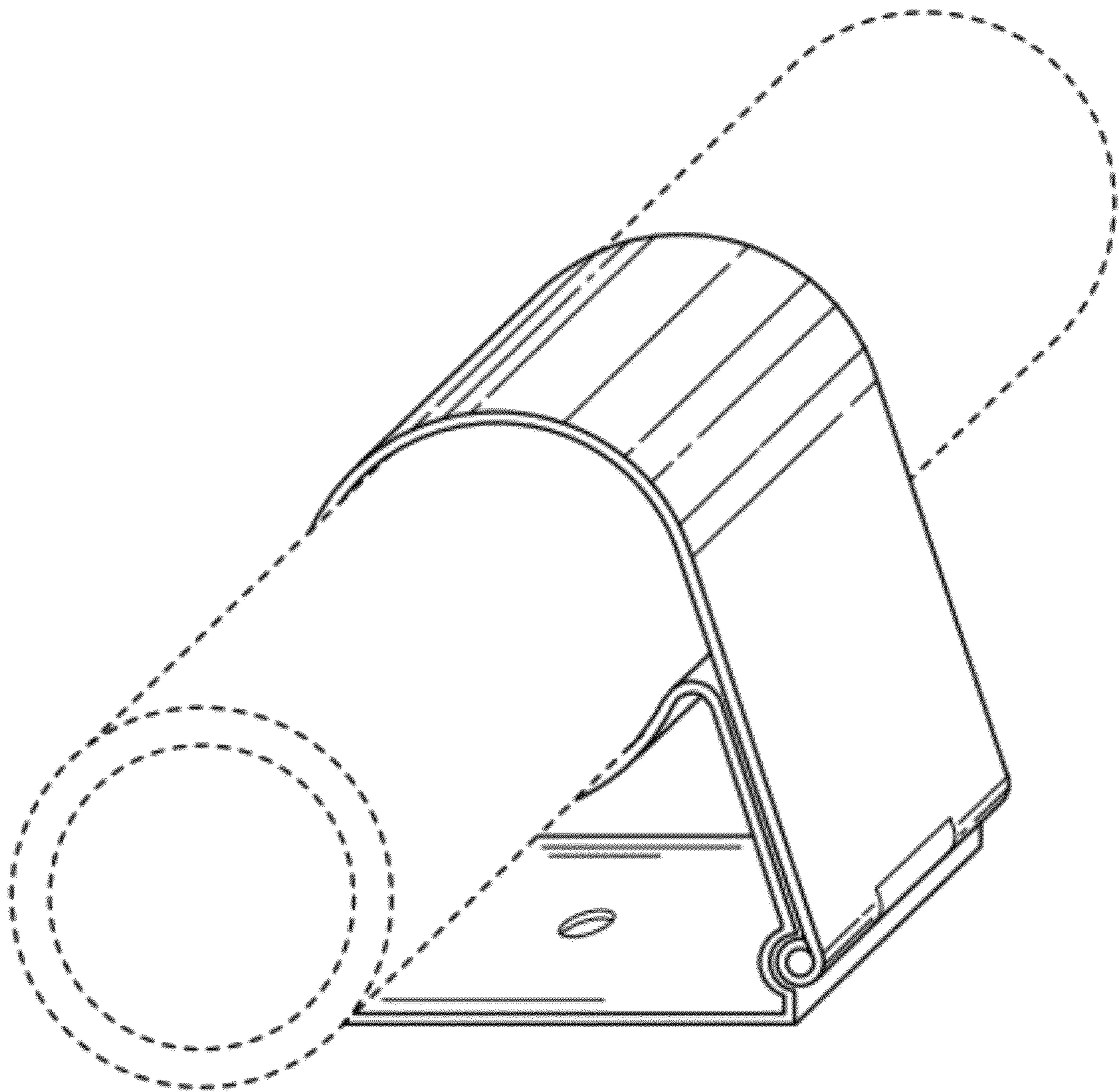
*Fig. 3*



*Fig. 4*



*Fig. 5*



*Fig. 6*