



US00D657895S

(12) **United States Design Patent**
Frenzel et al.

(10) **Patent No.:** **US D657,895 S**
(45) **Date of Patent:** **** Apr. 17, 2012**

(54) **TAILLIGHT FOR A VEHICLE**

(75) Inventors: **Klaus Frenzel**, Winnenden (DE);
Hans-Dieter Futschik, Gechingen (DE);
Stefan Handt, Stuttgart (DE); **Gorden**
Wagener, Stuttgart (DE); **Juergen**
Wiesen, Aidlingen (DE)

(73) Assignee: **Daimler AG**, Stuttgart (DE)

(**) Term: **14 Years**

(21) Appl. No.: **29/371,275**

(22) Filed: **Dec. 16, 2010**

(30) **Foreign Application Priority Data**

Jun. 30, 2010 (DE) 402010003490

(51) **LOC (9) Cl.** **26-06**

(52) **U.S. Cl.** **D26/28**

(58) **Field of Classification Search** D26/28-36;
362/459-468, 475-478, 485-487

See application file for complete search history.

(56) **References Cited**

U.S. PATENT DOCUMENTS

D511,716 S	11/2005	Pfeiffer	
D549,363 S *	8/2007	Pfeiffer	D26/28
D552,769 S *	10/2007	Leclercq	D26/28
D553,268 S *	10/2007	Pfeiffer	D26/28
D553,269 S *	10/2007	Pfeiffer et al.	D26/28
D565,211 S *	3/2008	Haller et al.	D26/28
D570,015 S *	5/2008	Hsu	D26/28
D592,770 S *	5/2009	Bauer et al.	D26/28
D605,793 S *	12/2009	Weil	D26/28

D620,157 S * 7/2010 Frenzel et al. D26/28
* cited by examiner

Primary Examiner — Marcus Jackson
(74) *Attorney, Agent, or Firm* — Crowell & Moring LLP

(57) **CLAIM**

The ornamental design for a taillight for a vehicle, as shown and described.

DESCRIPTION

This application contains subject matter related to the following co-pending U.S. design patent applications:

Application Ser. No. 29/371,267, filed herewith and entitled “Vehicle, Toy, and/or Replicas Thereof”;

Application Ser. No. 29/371,269, filed herewith and entitled “Rear Portion of a Vehicle, Toy, and/or Replicas Thereof”;

Application Ser. No. 29/371,274, filed herewith and entitled “Taillight for a Vehicle”; and

Application Ser. No. 29/371,276, filed herewith and entitled “Taillight for a Vehicle”.

FIG. 1 is a left perspective view of a first embodiment of a taillight for a vehicle according to our design;

FIG. 2 is a front view thereof;

FIG. 3 is a left side view thereof; and

FIG. 4 is a top view thereof.

FIG. 5 is a right perspective view of a second embodiment of the taillight for a vehicle according to our design, with the taillight for a Vehicle for the opposite side of the vehicle being depicted in the first embodiment;

FIG. 6 is a front view thereof;

FIG. 7 is a right side view thereof; and,

FIG. 8 is a top view thereof.

The broken lines are for illustrative purposes only and form no part of the claimed design.

1 Claim, 4 Drawing Sheets

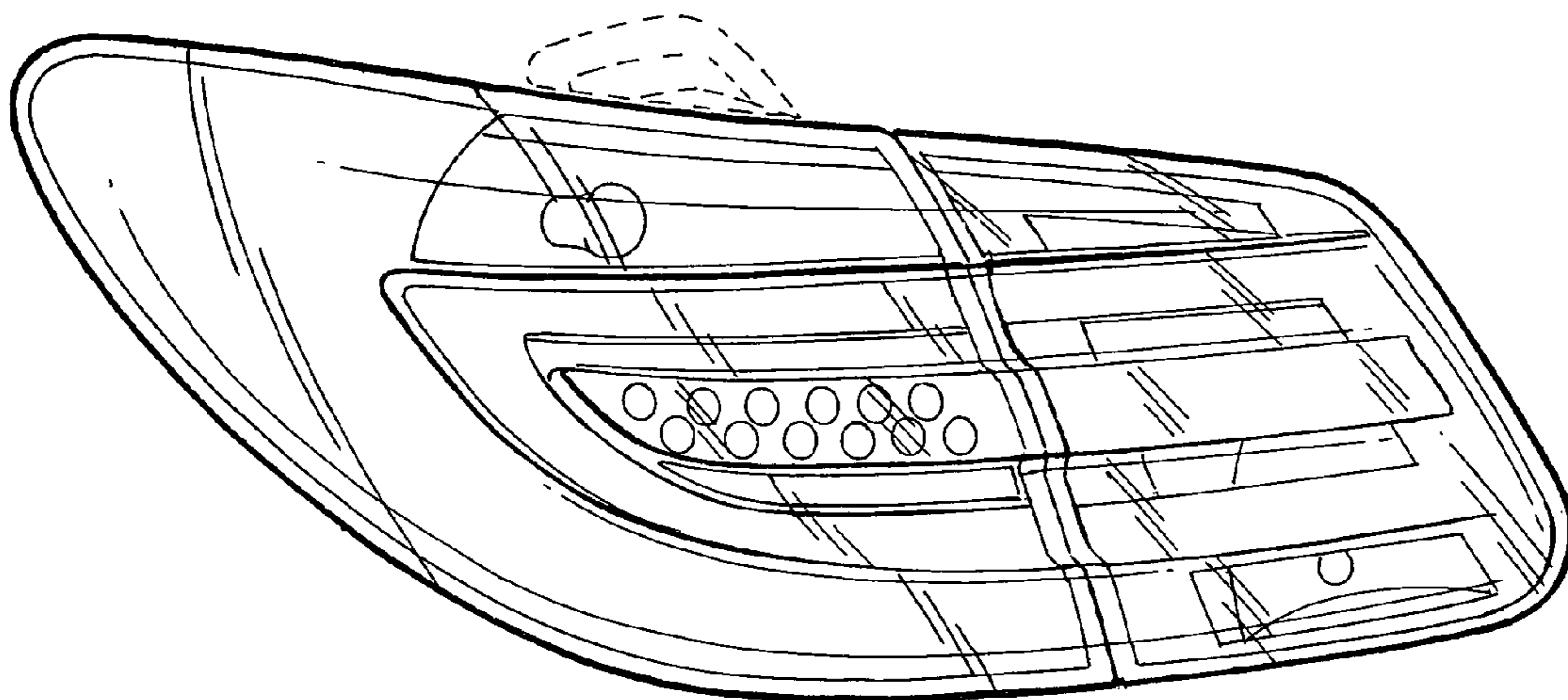

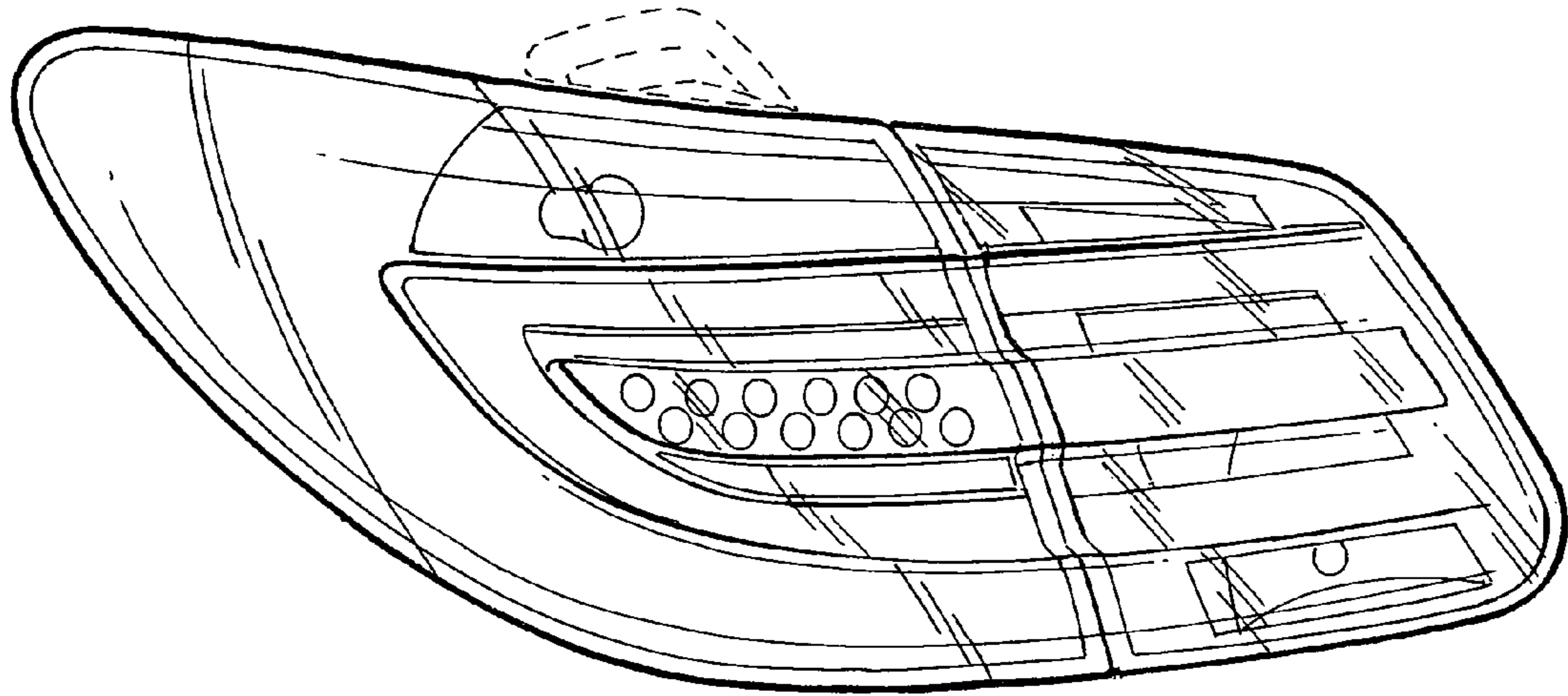

FIG. 1

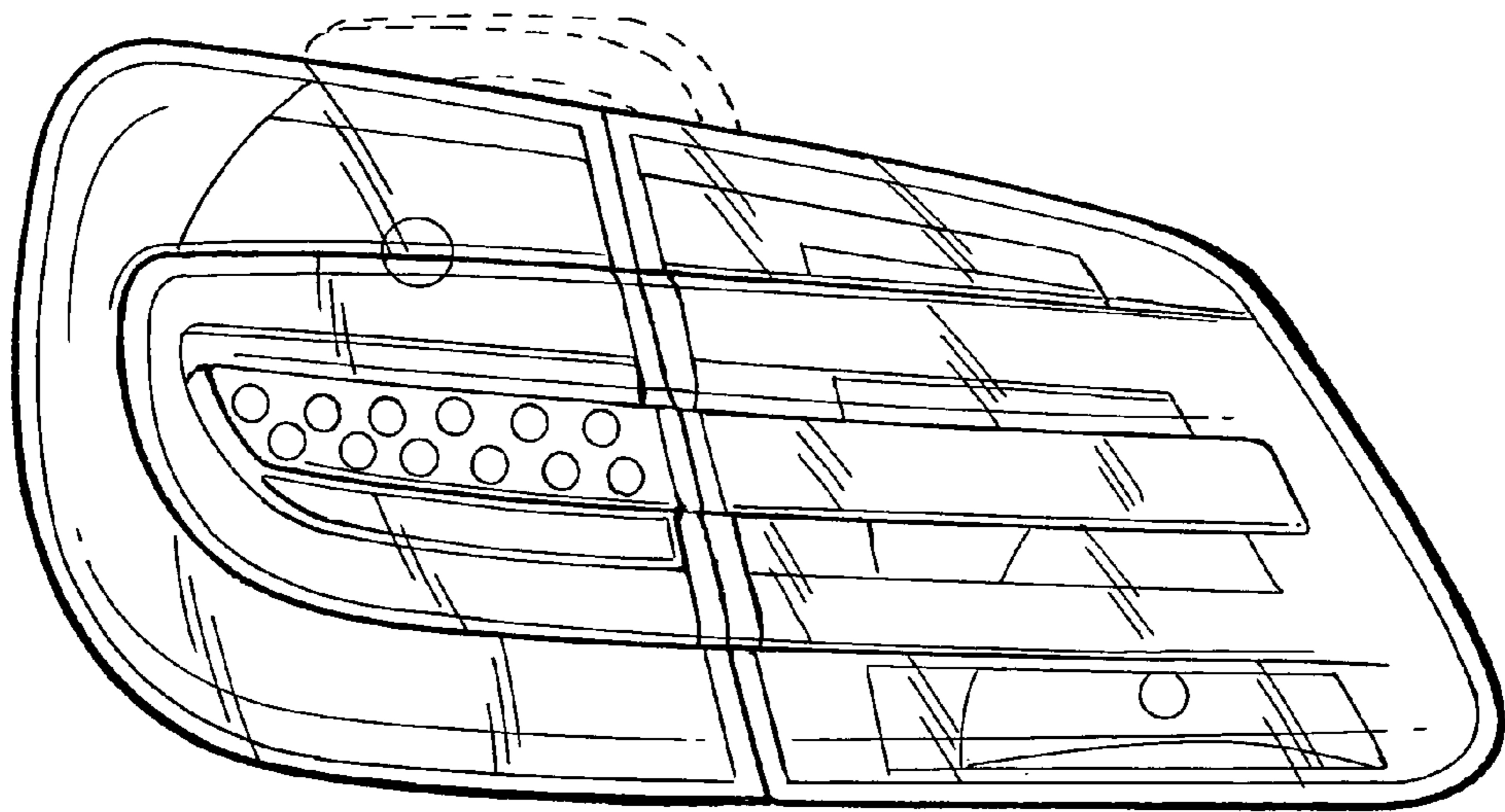

FIG. 2

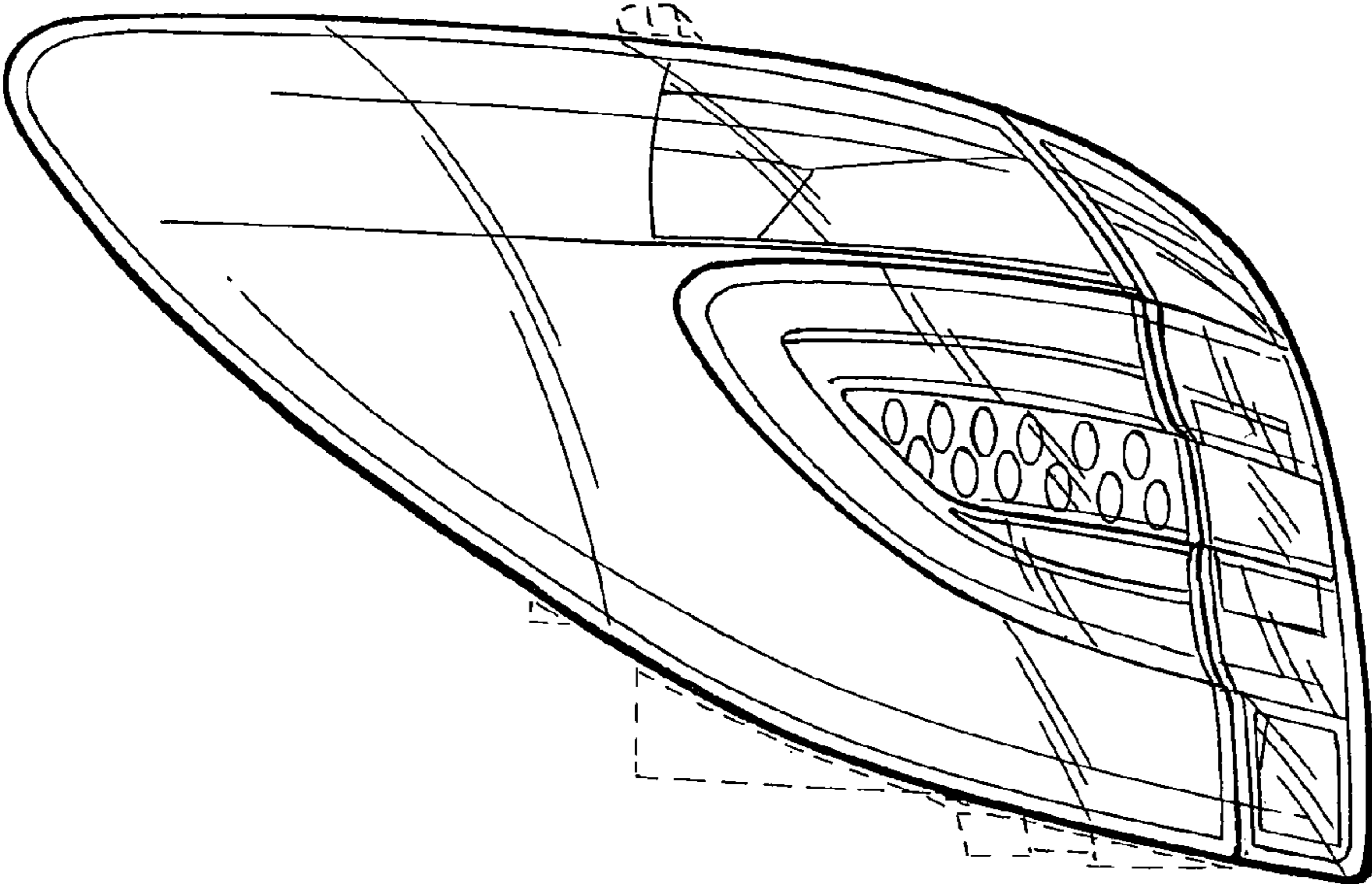

FIG. 3

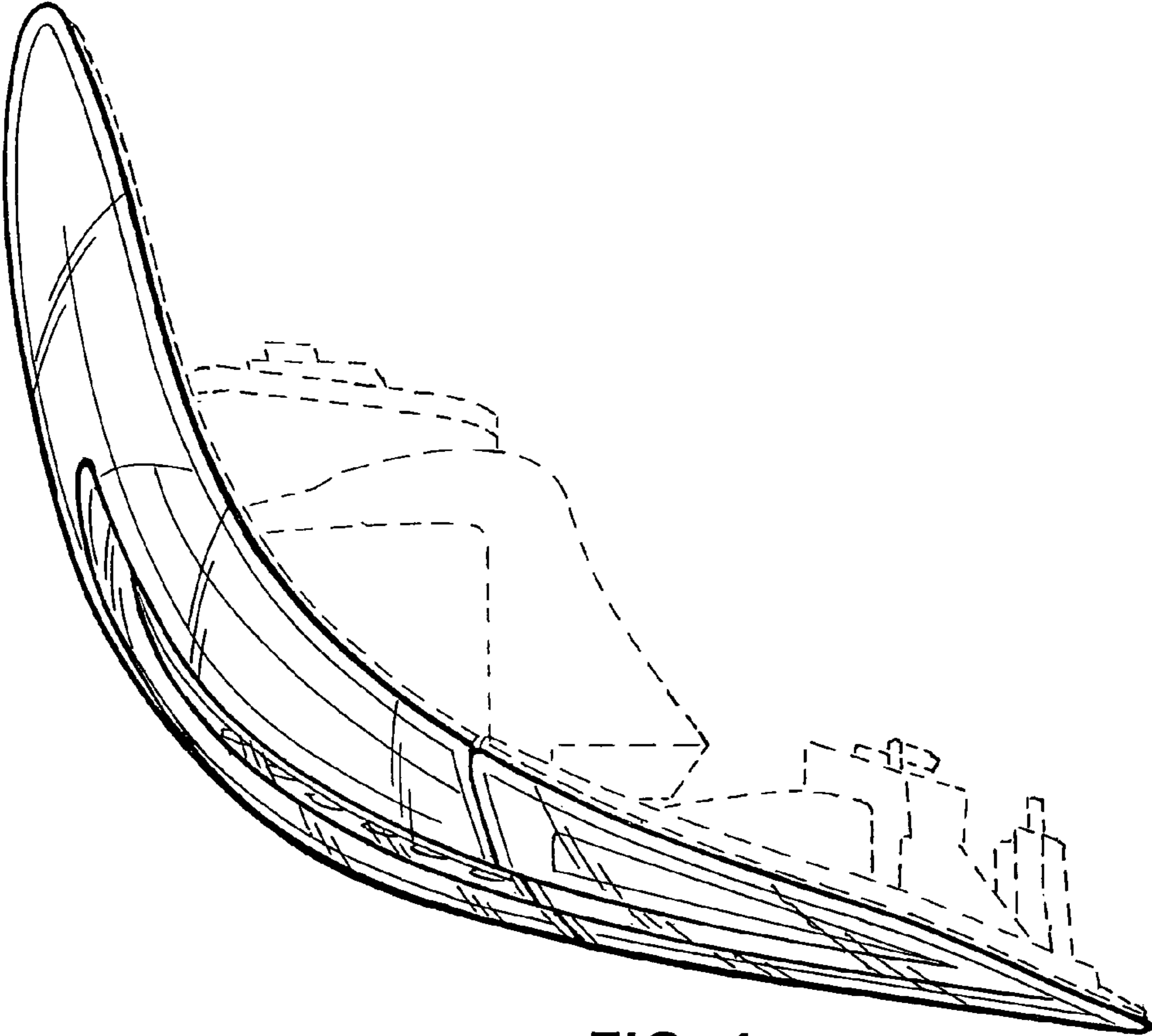

FIG. 4

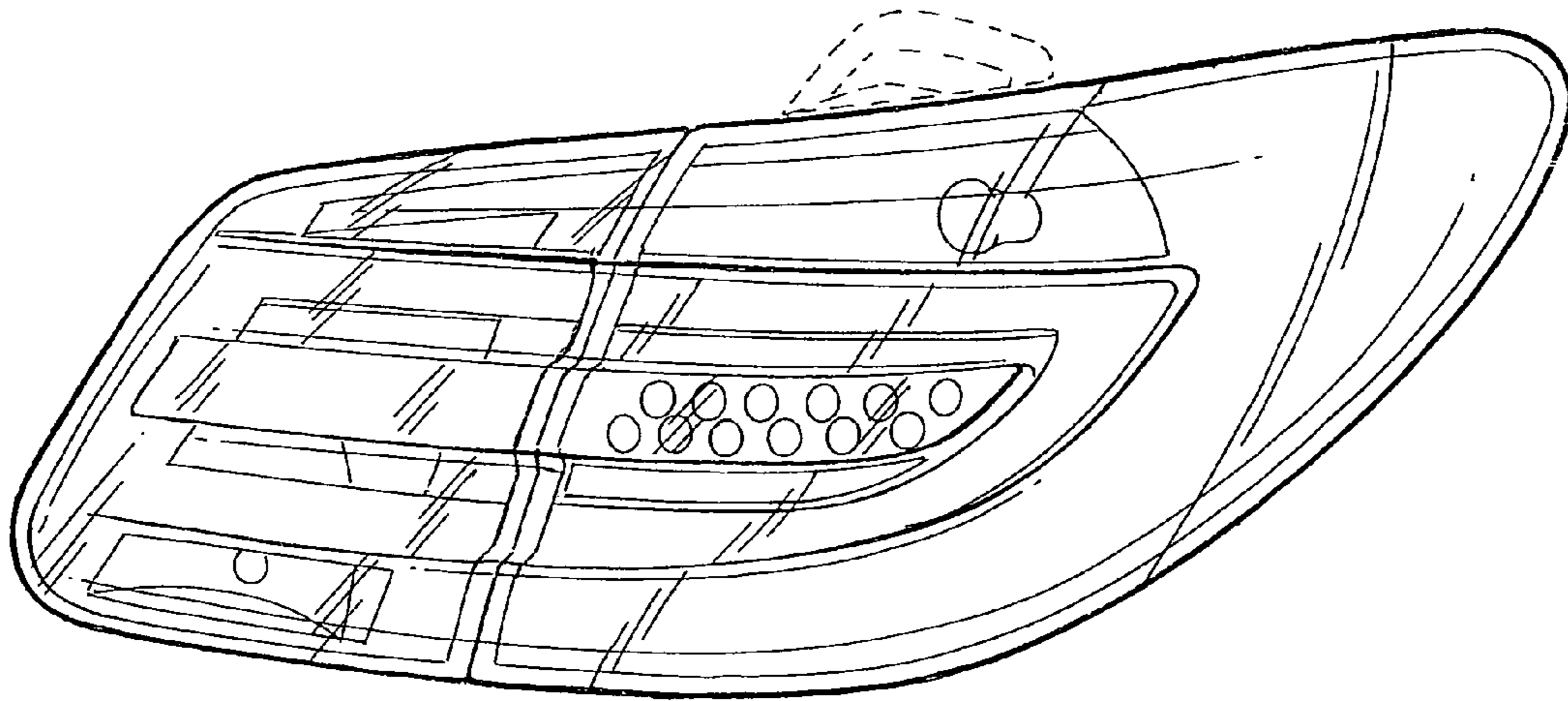

FIG. 5

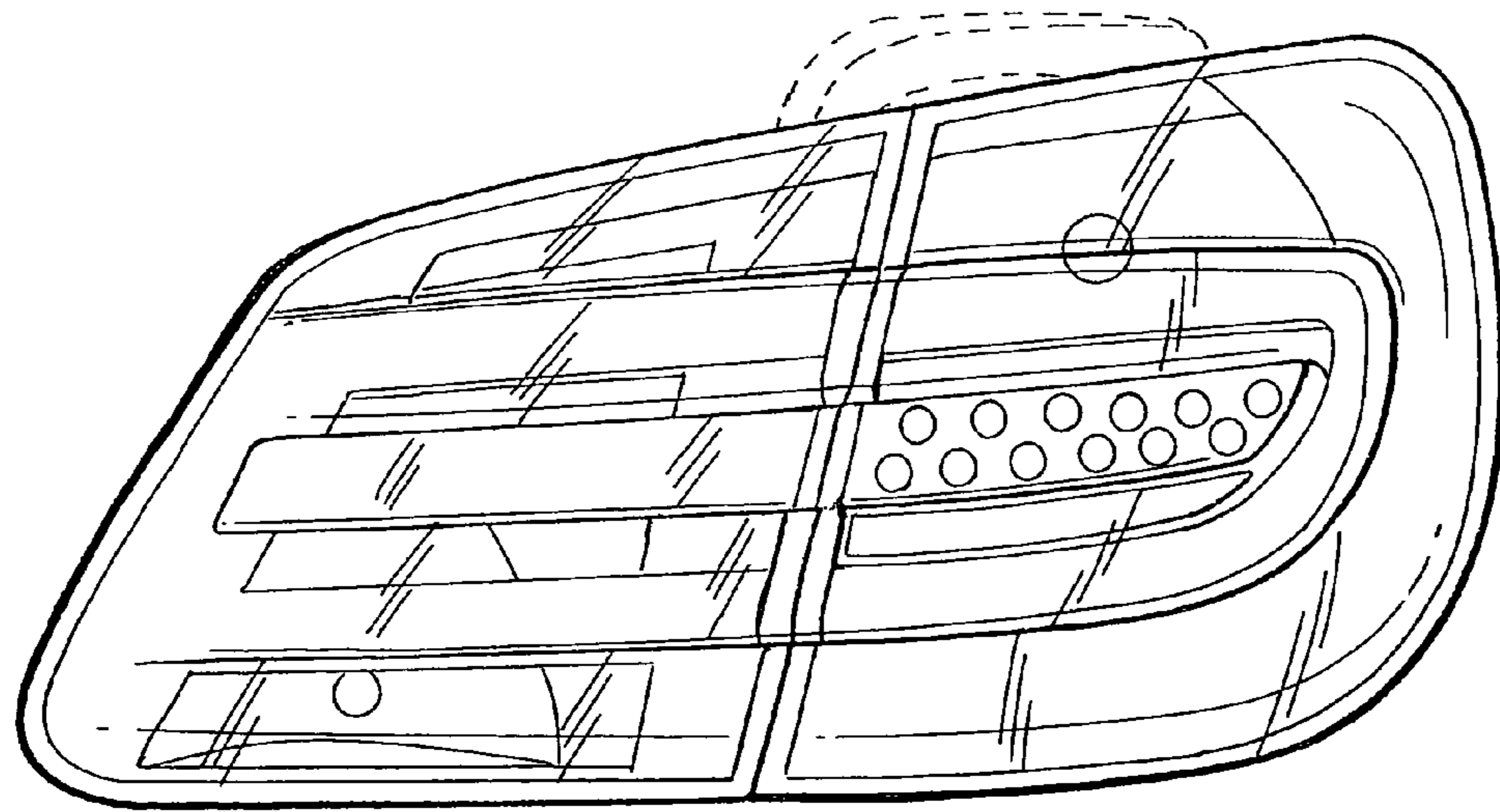

FIG. 6

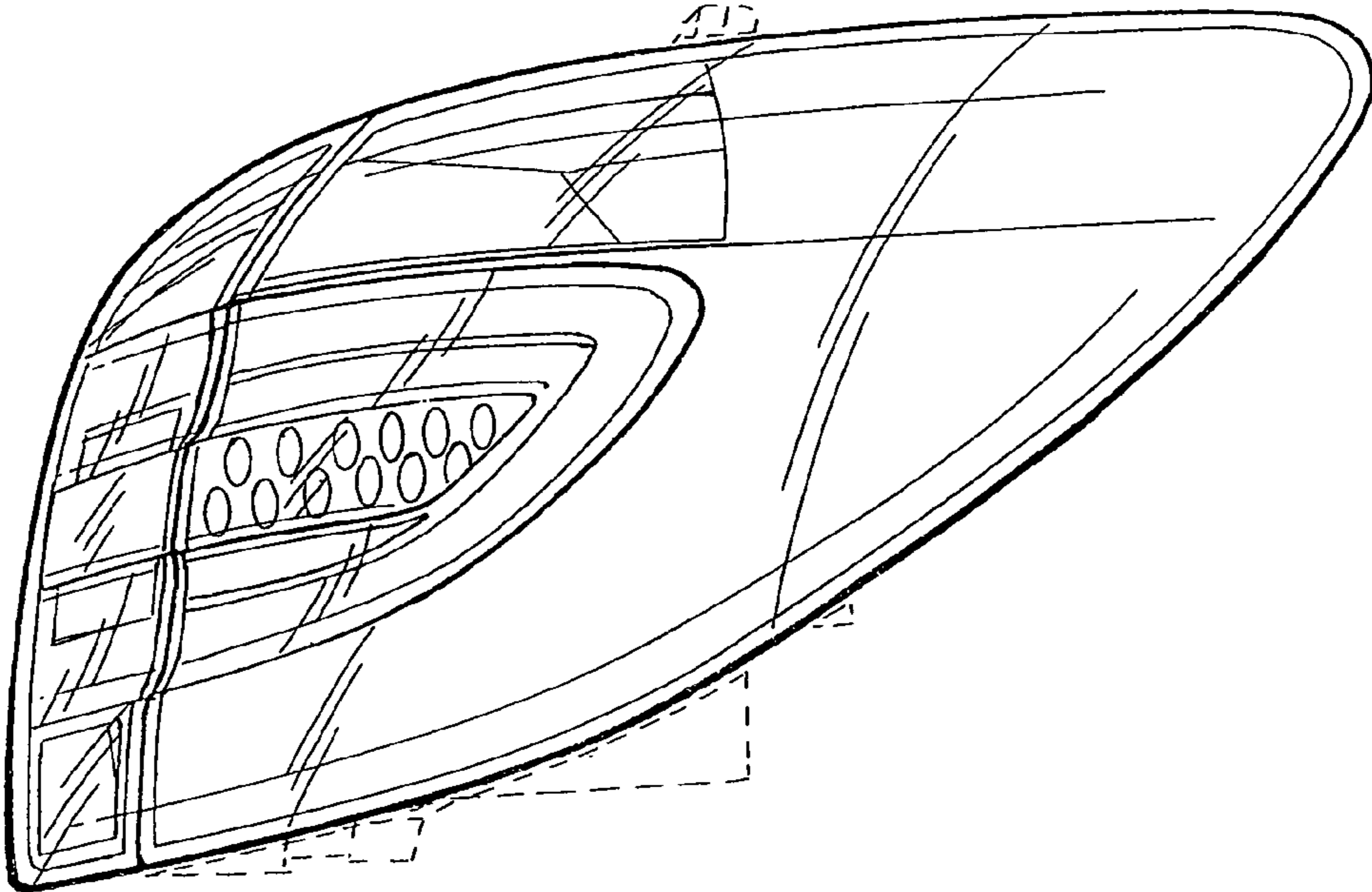

FIG. 7

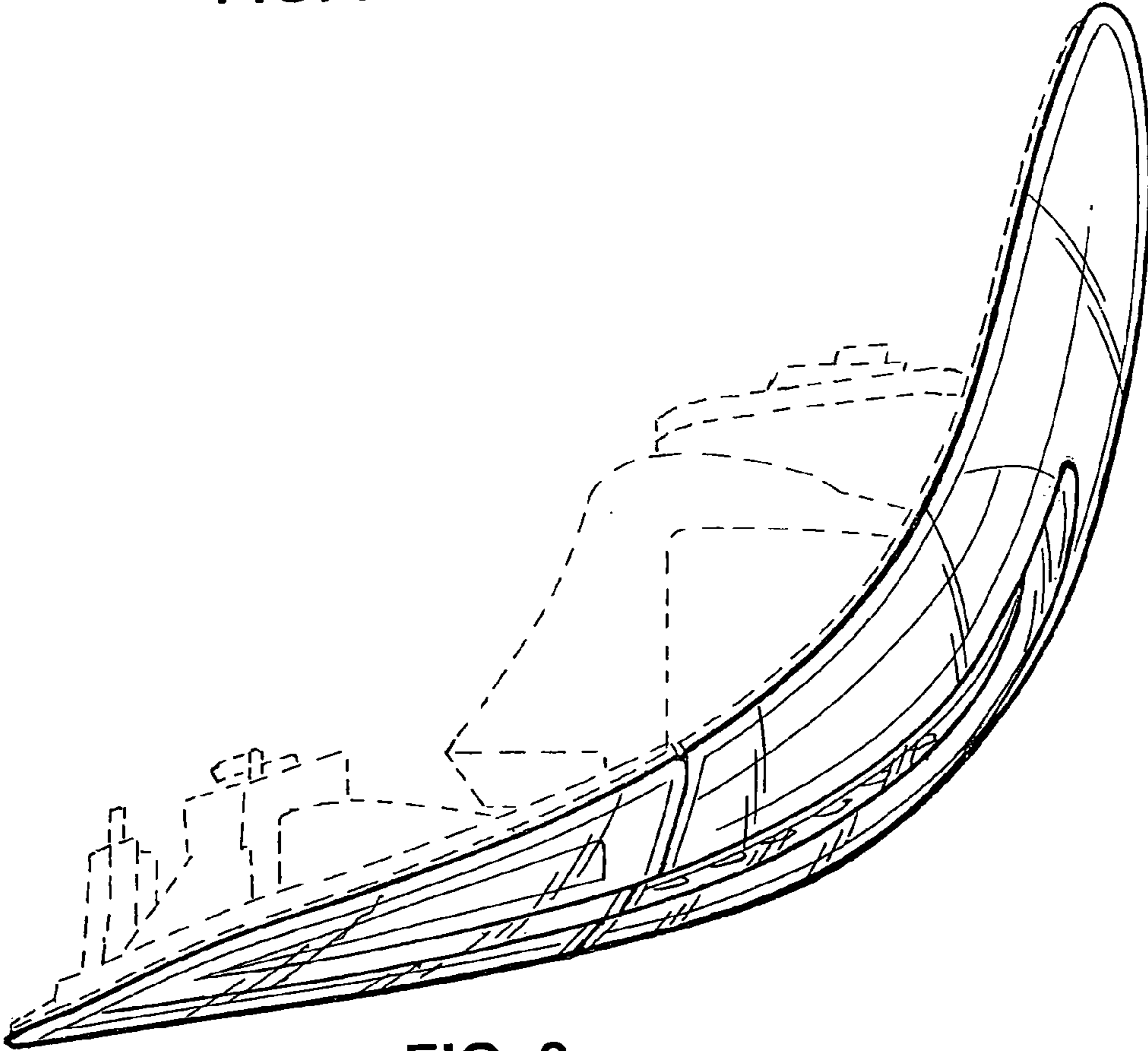

FIG. 8