



US00D657615S

(12) **United States Design Patent**
Pierce

(10) **Patent No.:** **US D657,615 S**

(45) **Date of Patent:** **** Apr. 17, 2012**

(54) **BAKING PAN**

(76) Inventor: **Heather Pierce**, Dallas, TX (US)

(**) Term: **14 Years**

(21) Appl. No.: **29/399,419**

(22) Filed: **Aug. 13, 2011**

(51) **LOC (9) Cl.** **07-02**

(52) **U.S. Cl.** **D7/354; D7/361**

(58) **Field of Classification Search** D3/204–207;
D4/124; D7/323, 329–332, 337, 339, 346–347,
D7/350.1–350.4, 354–363, 391, 393, 395,
D7/402, 408–409, 505, 538, 542, 549, 553.1,
D7/553.6, 553.8, 587, 667; D8/38, 348,
D8/356; D9/430, 436, 665; D14/400, 456;
D17/14, 18–20; D21/483; 84/291; 99/324–325,
99/331–332, 337–340, 396, 400–418, 425,
99/444–446, 450; 206/501–505, 507–508,
206/540; 220/485, 491, 573.1–573.5, 574,
220/759, 912

See application file for complete search history.

(56) **References Cited**

U.S. PATENT DOCUMENTS

D117,478 S *	11/1939	Keenan	D7/549
D181,867 S *	1/1958	McCarty	D17/19
D201,696 S *	7/1965	Zorn	D7/549
D287,578 S	1/1987	Shay et al.		
D296,404 S *	6/1988	Lowenbein	D7/553.1
D300,408 S	3/1989	Couri		
4,890,529 A *	1/1990	Grant	84/291
D349,408 S *	8/1994	Cameron	D4/124
D418,859 S *	1/2000	Herbold	D17/20
D435,756 S	1/2001	Emrich		
D440,869 S	4/2001	Leach		
D499,961 S	12/2004	Wilson		
D544,767 S *	6/2007	Kelleghan	D8/38
D562,058 S	2/2008	Costa		
D566,121 S *	4/2008	Yow et al.	D14/456

D572,301 S *	7/2008	Li	D17/18
D604,179 S	11/2009	Rodriguez		
D613,108 S	4/2010	Tosdale et al.		
D613,148 S *	4/2010	Rand	D8/348
D619,476 S	7/2010	McClellan et al.		
D633,370 S *	3/2011	Rand	D8/348
D648,977 S *	11/2011	Malaspino et al.	D7/354
2011/0146502 A1	6/2011	Mansur		

* cited by examiner

Primary Examiner — Ricky Pham

(74) *Attorney, Agent, or Firm* — Sheri Higgins Law; Sheri Higgins

(57) **CLAIM**

The ornamental design for a baking pan, as shown and described.

DESCRIPTION

FIG. 1 is an exploded perspective view of a first embodiment of a body of a guitar-shaped baking pan. The body of a guitar-shaped baking pan is shown in conjunction with a neck of a guitar, wherein the neck of the guitar is shown in broken lines to illustrate the environment only and forms no part of the claimed design.

FIG. 2 is top view thereof.

FIG. 3 is a bottom view thereof.

FIG. 4 is a right-side view thereof.

FIG. 5 is a left-side view thereof.

FIG. 6 is a front view thereof. It is to be understood that the rear of the baking pan is a mirror image of the front view illustrated; and,

FIG. 7 is a bottom view of a second embodiment of the baking pan, the broken line showing the rim of the baking pan is for illustrative purposes only and forms no part of the claimed design. According to this second embodiment, the perspective, top, right side, left side, and front and rear of the baking pan are the same as depicted in FIGS. 1, 2, 4, 5, and 6 except without the rim.

1 Claim, 4 Drawing Sheets

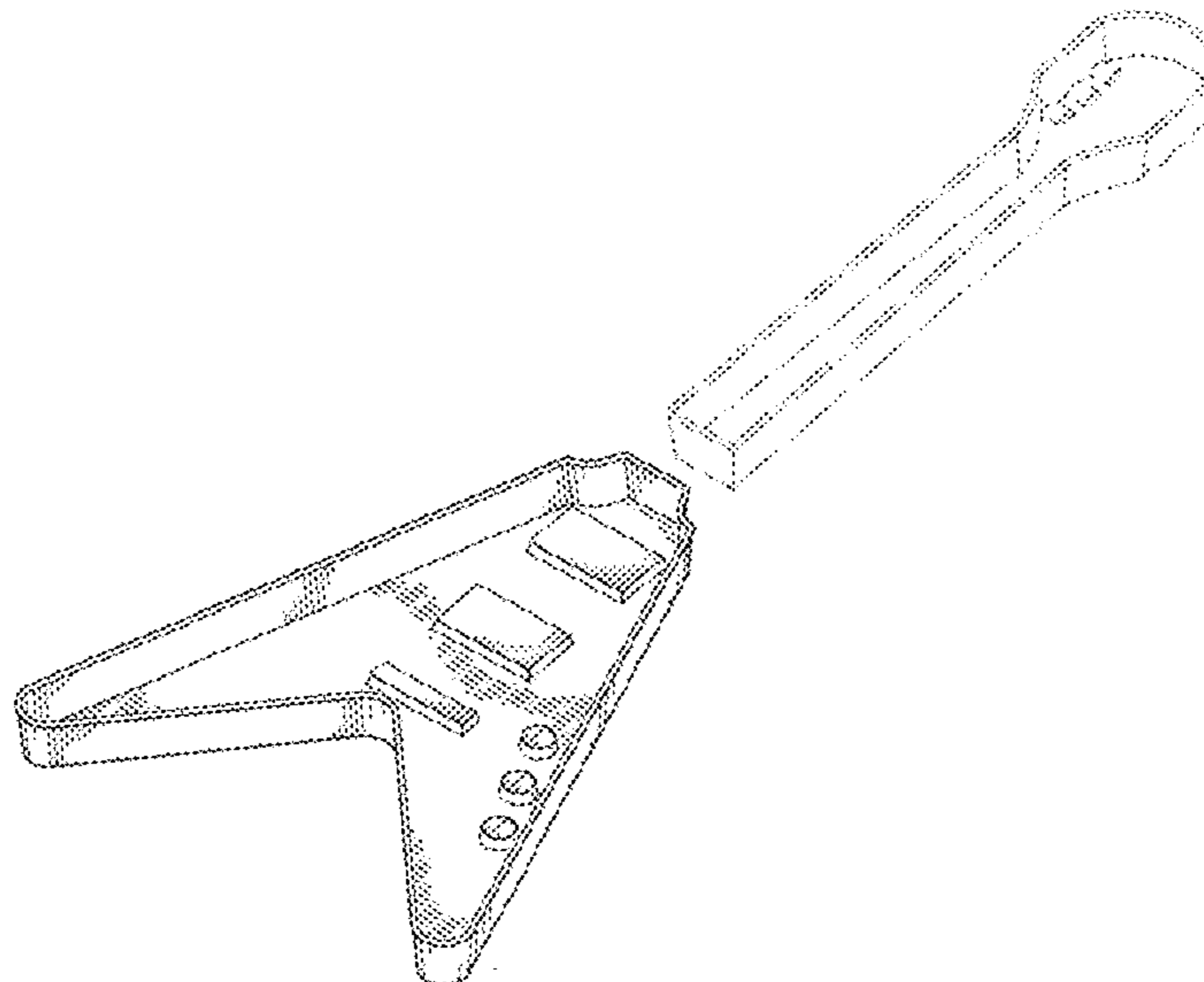

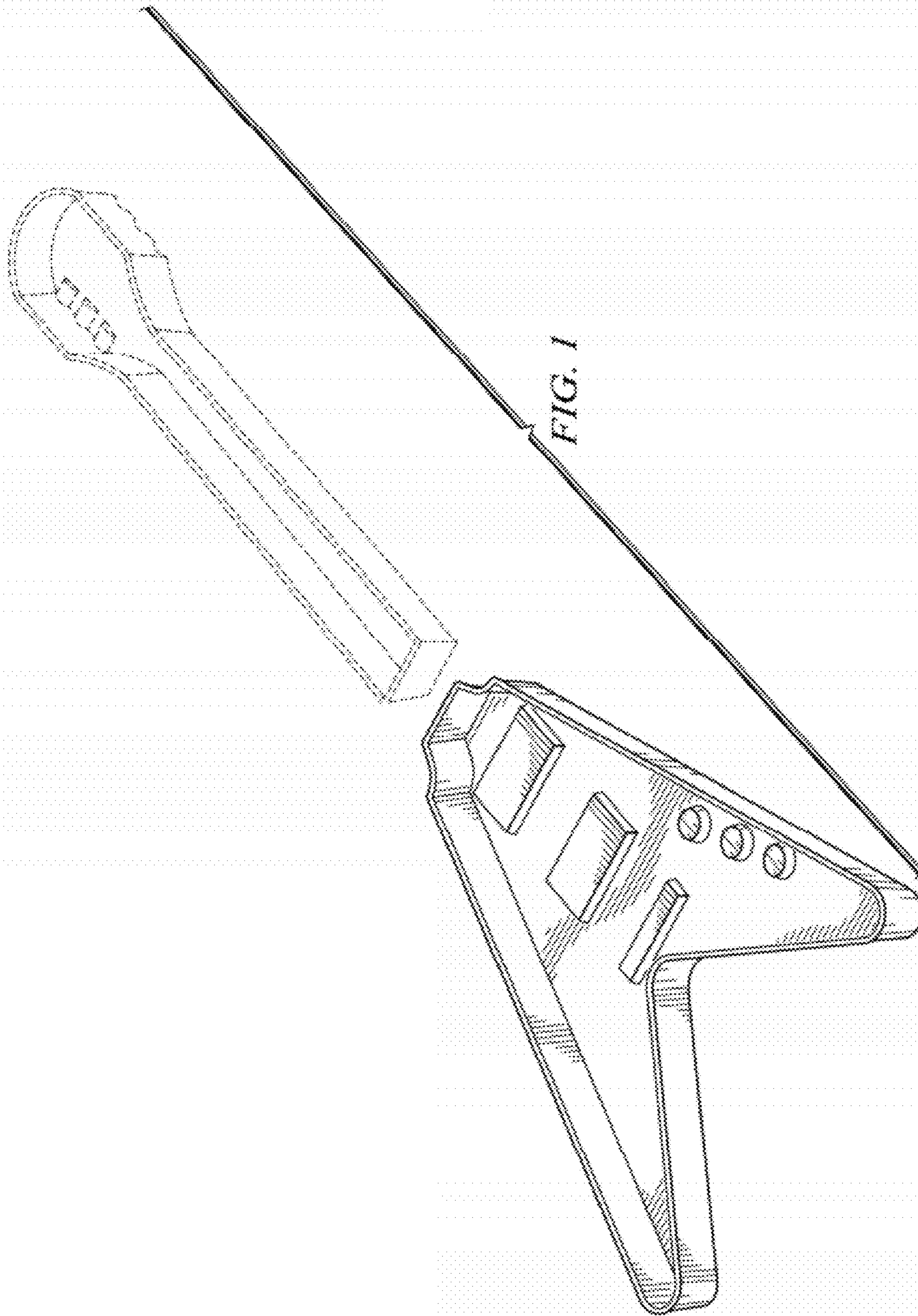

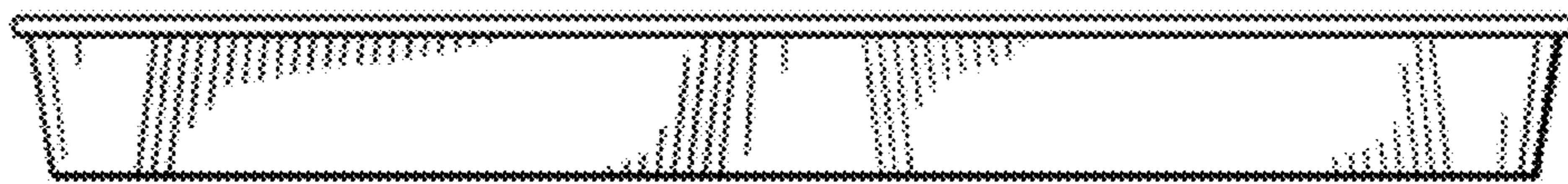
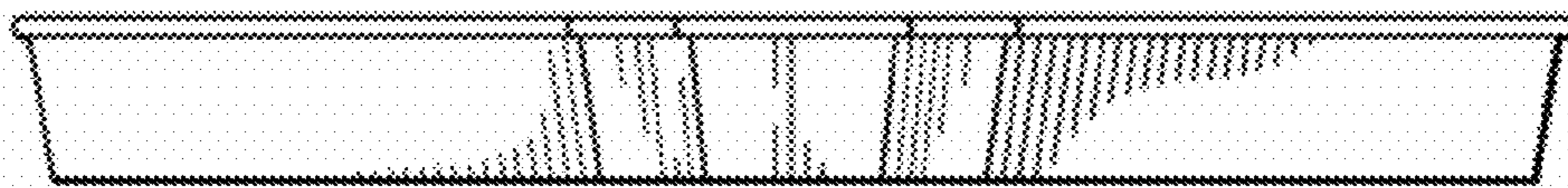
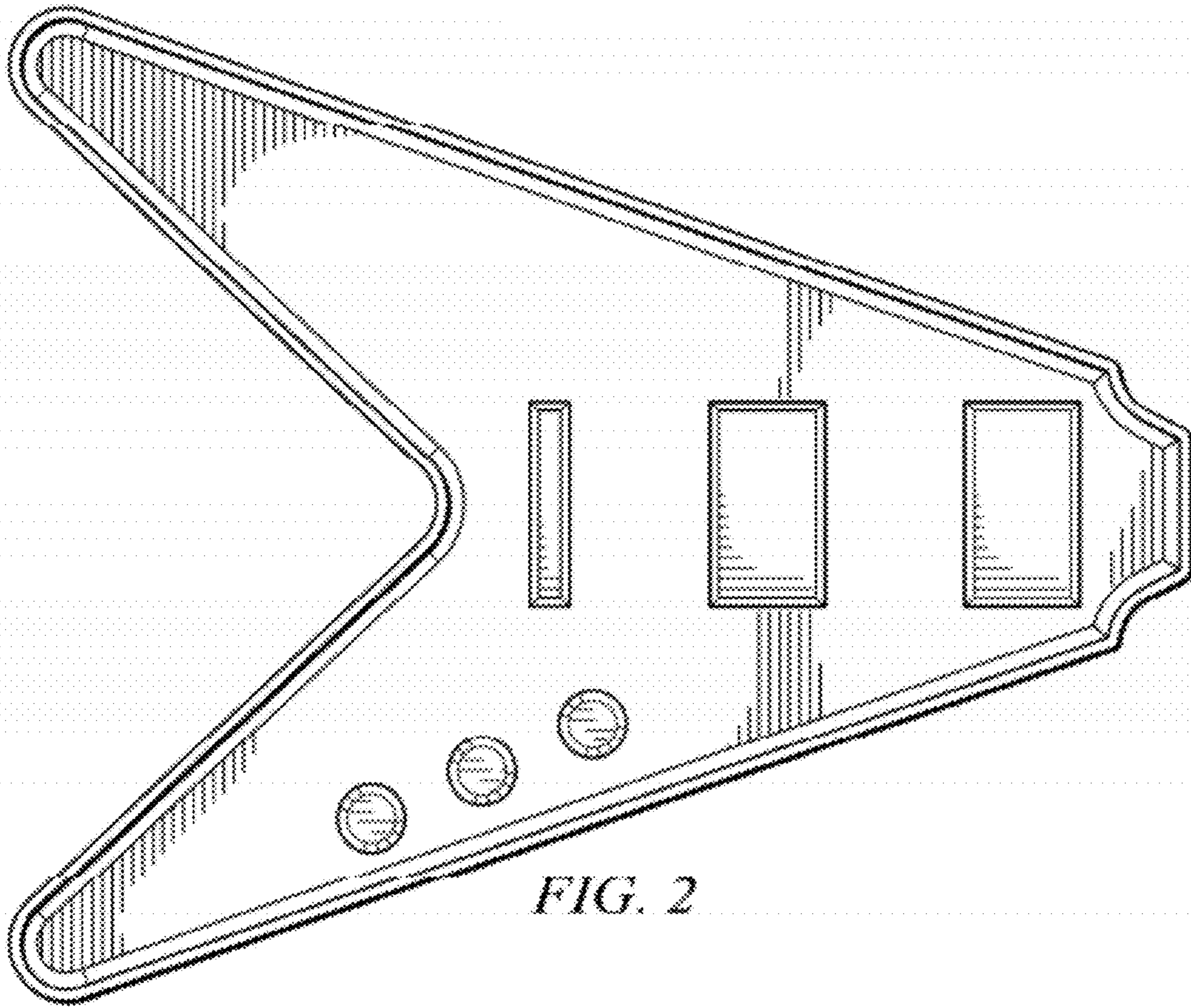

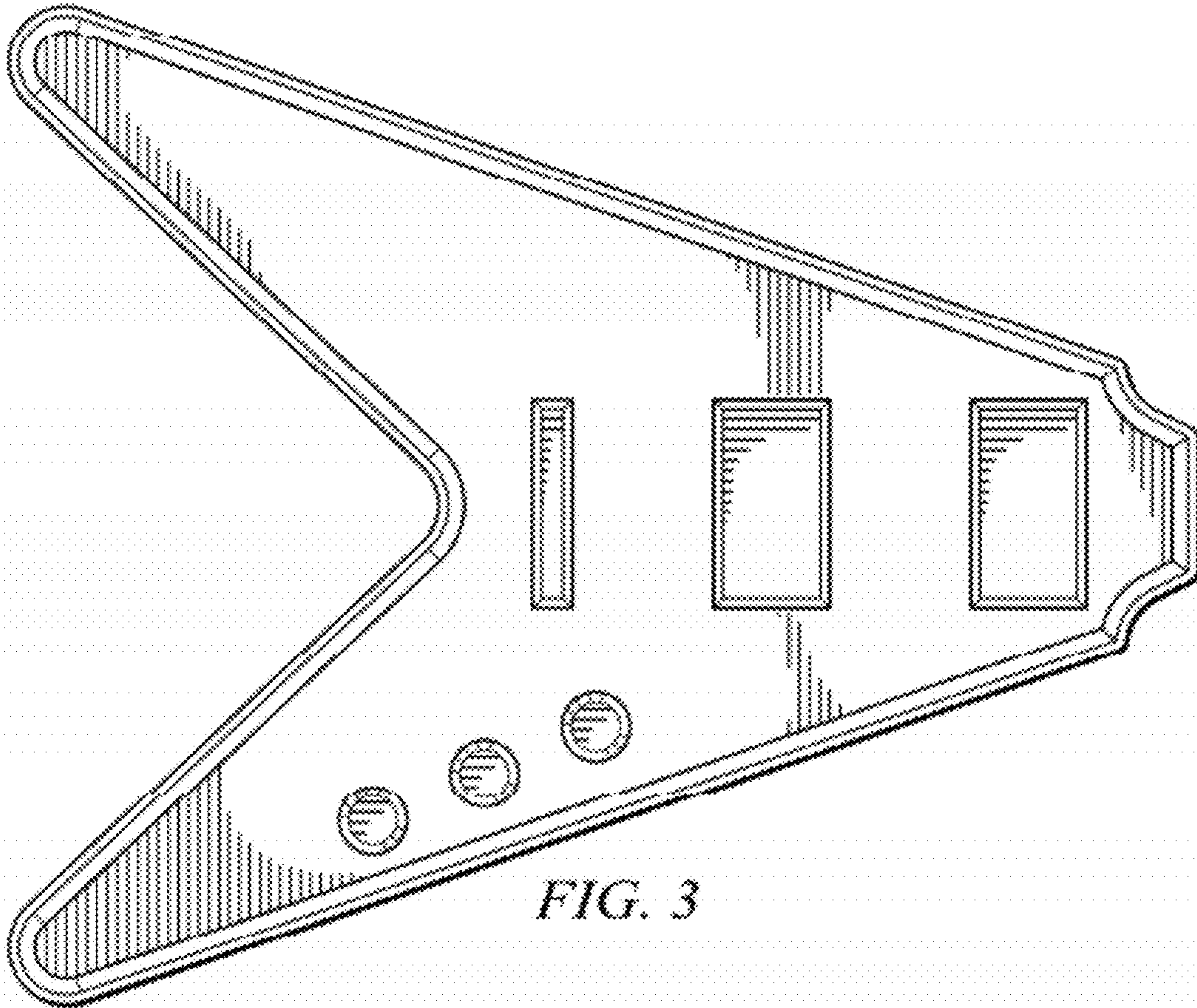

FIG. 3

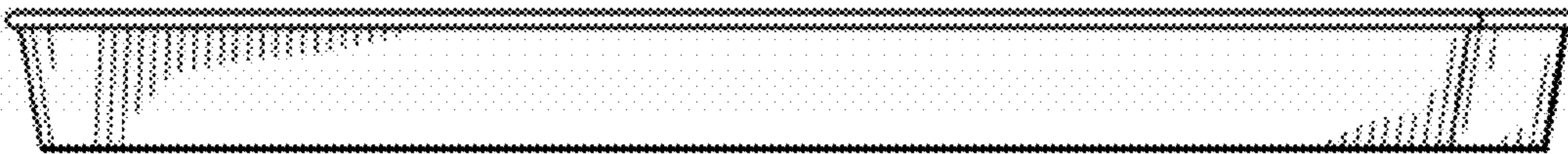

FIG. 6

