



US00D657516S

(12) **United States Design Patent**  
**McGee et al.**

(10) **Patent No.:** **US D657,516 S**  
(45) **Date of Patent:** **\*\* Apr. 10, 2012**

(54) **STEAM MOP**

(75) Inventors: **Brian R McGee**, Acton, MA (US);  
**Stuart D Babb**, Milton, MA (US)

(73) Assignee: **Euro-Pro Operating LLC**, Newton,  
MA (US)

(\*\*) Term: **14 Years**

(21) Appl. No.: **29/379,452**

(22) Filed: **Nov. 19, 2010**

(51) **LOC (9) Cl.** ..... **04-01**

(52) **U.S. Cl.** ..... **D32/45**

(58) **Field of Classification Search** ..... D32/40,  
D32/45, 50, 51; 401/137-140, 40-42; 141/20.5  
See application file for complete search history.

(56) **References Cited**

**U.S. PATENT DOCUMENTS**

D296,486 S	6/1988	Staubitz et al.	
D362,937 S	10/1995	Camp, Jr. et al.	
5,455,980 A	10/1995	Buchanan	
D391,715 S	3/1998	Irwin et al.	
D398,099 S	9/1998	Leung	
D401,703 S	11/1998	Beechuk et al.	
6,045,622 A	4/2000	Holt et al.	
D466,786 S	12/2002	Bourgeois et al.	
6,588,045 B2	7/2003	Fernandez	
6,601,261 B1	8/2003	Holt et al.	
D497,699 S	10/2004	Chi-Hsiang et al.	
6,871,372 B2	3/2005	Vosbikian et al.	
D505,762 S	5/2005	Lalanne et al.	
D507,088 S *	7/2005	Chi-Hsiang et al. ....	D32/45
D510,467 S	10/2005	Kizaki et al.	
6,960,042 B1 *	11/2005	Hsiao .....	401/138

6,979,371 B1	12/2005	Policicchio et al.	
D514,267 S	1/2006	Tsai	
D515,759 S	2/2006	Fischer	
D583,118 S *	12/2008	Snyder .....	D32/51
D591,921 S	5/2009	Rosenzweig et al.	
D597,717 S	8/2009	Rosenzweig et al.	
D602,218 S *	10/2009	Koenig et al. ....	D32/40
D607,168 S *	12/2009	Libman et al. ....	D32/45
D615,260 S *	5/2010	Koenig .....	D32/45
D625,481 S *	10/2010	Raven .....	D32/51
D631,217 S *	1/2011	Lavy .....	D32/45
D636,958 S *	4/2011	Koenig et al. ....	D32/45

\* cited by examiner

*Primary Examiner* — Robin V Webster

(74) *Attorney, Agent, or Firm* — Wolf, Greenfield & Sacks,  
P.C.

(57) **CLAIM**

The ornamental design for a steam mop, as shown and described.

**DESCRIPTION**

FIG. 1 is a perspective view of a steam mop in accordance with the present design;  
FIG. 2 is a front view thereof;  
FIG. 3 is a rear view thereof;  
FIG. 4 is a left side view thereof;  
FIG. 5 is a right side view thereof;  
FIG. 6 is a top plan view thereof; and,  
FIG. 7 is a bottom plan view thereof.  
The broken lines showing mop handle, power supply cord and mop head are for illustrative purposes only and form no part of the claimed design.

**1 Claim, 3 Drawing Sheets**

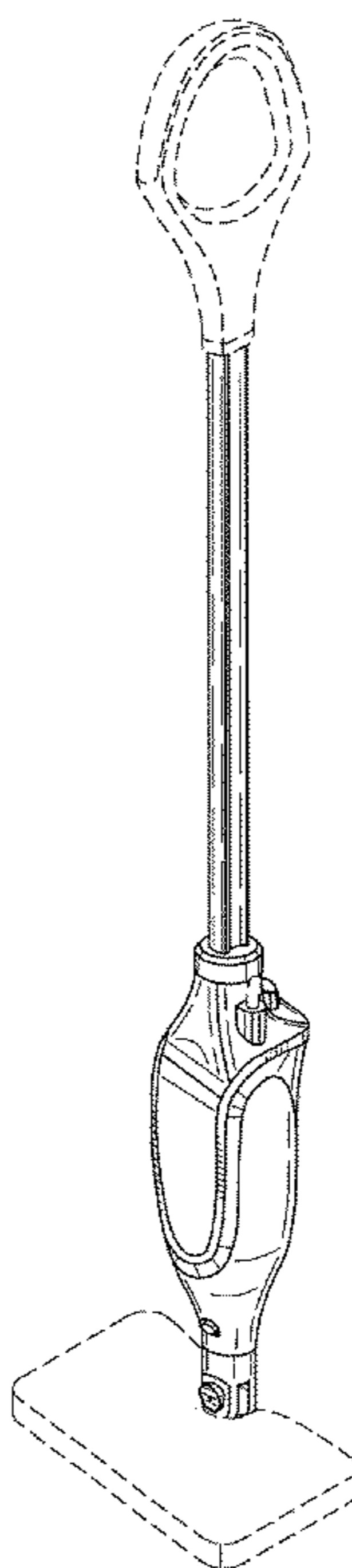

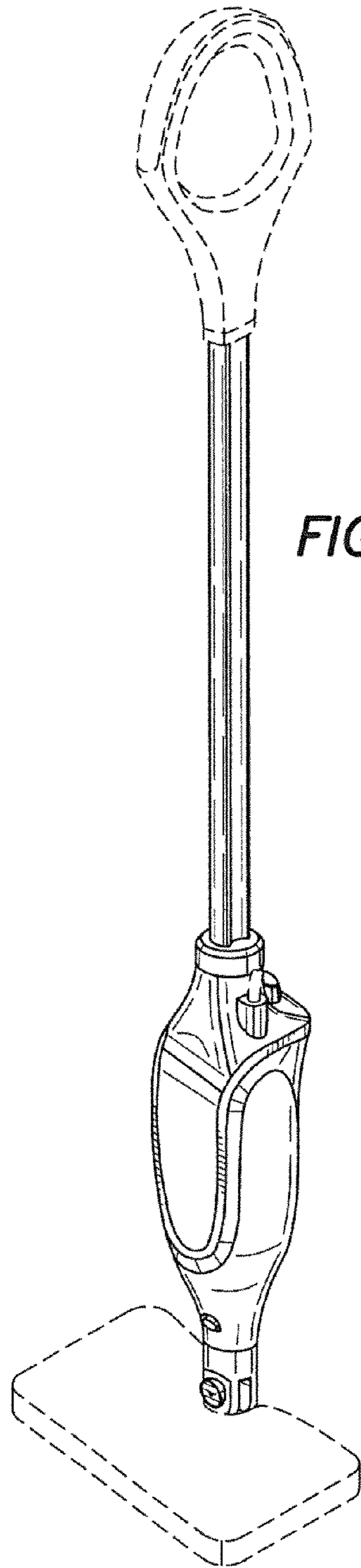

FIG. 1

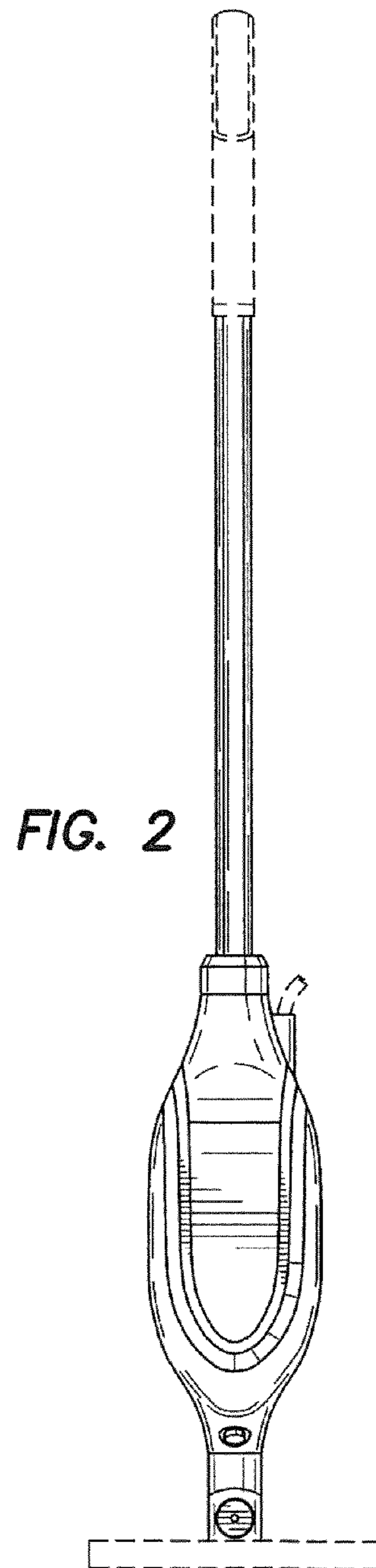

FIG. 2

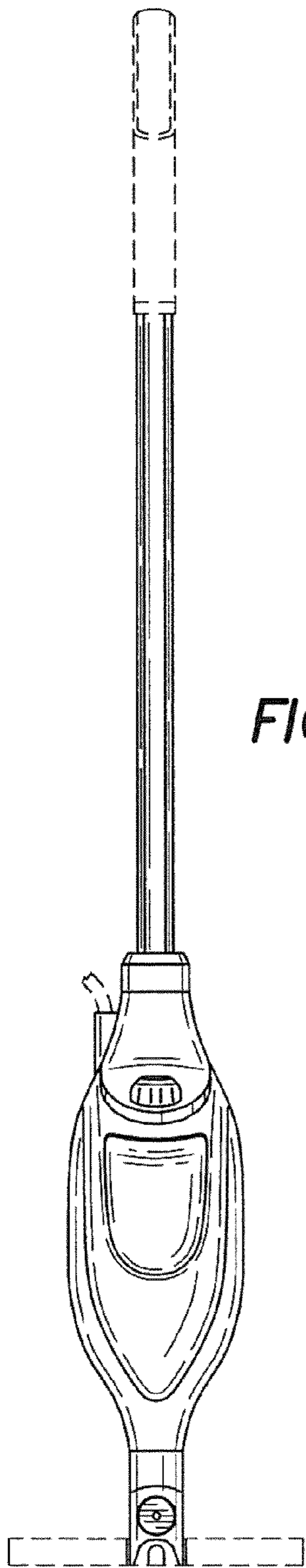

FIG. 3

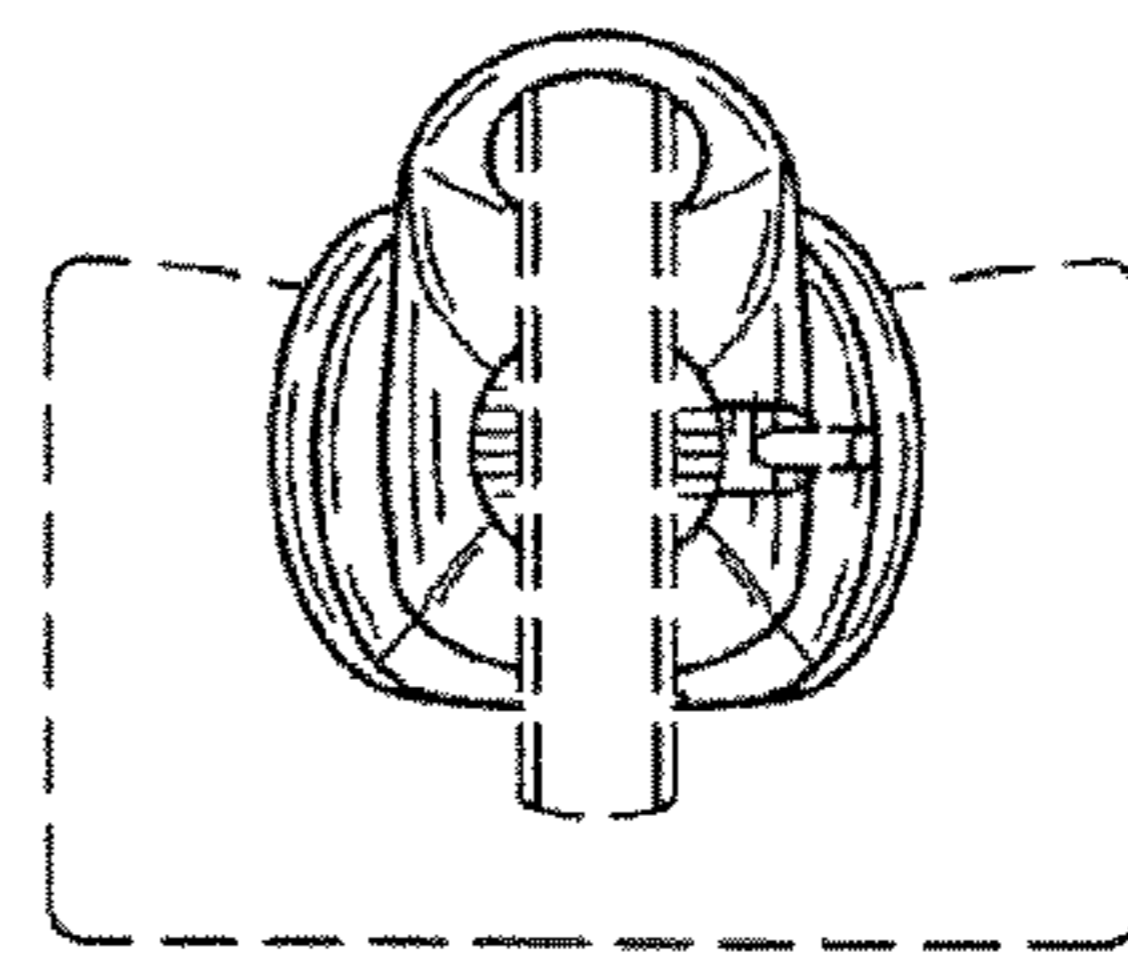

FIG. 6

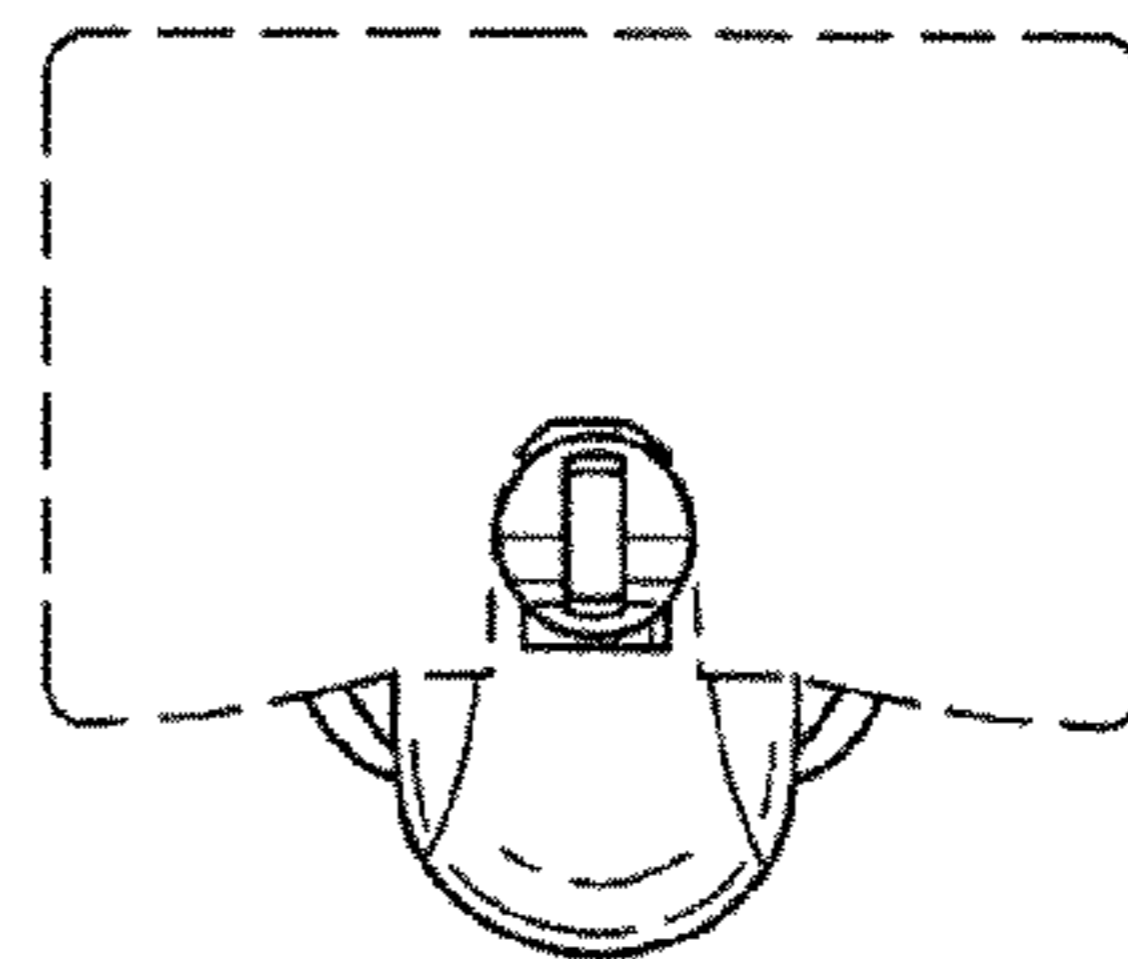

FIG. 7

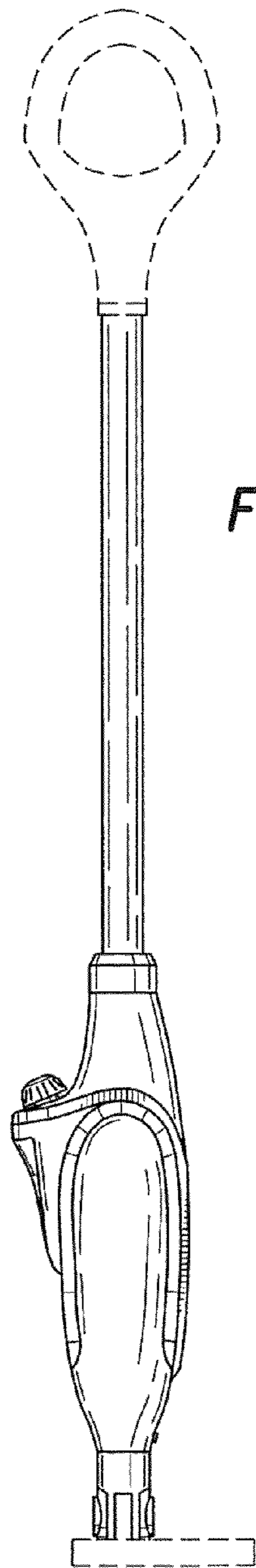

FIG. 4

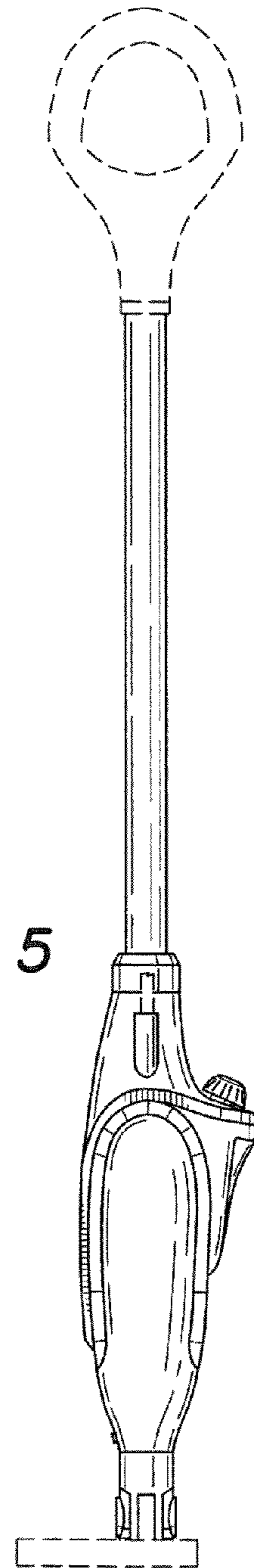

FIG. 5