



US00D657056S

(12) **United States Design Patent**
Burgess et al.

(10) **Patent No.:** **US D657,056 S**
(45) **Date of Patent:** **** Apr. 3, 2012**

(54) **MEDICAL PORT**

(75) Inventors: **James E. Burgess**, Mundelein, IL (US);
John H. Kutsch, Harvard, IL (US)

(73) Assignee: **Medline Industries, Inc.**, Mundelein, IL (US)

(**) Term: **14 Years**

(21) Appl. No.: **29/344,747**

(22) Filed: **Oct. 2, 2009**

(51) **LOC (9) Cl.** **24-02**

(52) **U.S. Cl.** **D24/129**

(58) **Field of Classification Search** D24/110,
D24/129; 604/905, 256, 246, 83, 167.01,
604/167.02, 167.03, 167.04, 533, 538, 539,
604/284, 523, 546

See application file for complete search history.

(56) **References Cited**

U.S. PATENT DOCUMENTS

2,538,662	A *	1/1951	Abbott	604/247
D252,470	S *	7/1979	Pawlak	D24/129
D259,278	S *	5/1981	McCaw et al.	D24/129
D283,725	S *	5/1986	Mahoney	D23/235
D300,361	S *	3/1989	Tokarz	D24/129
D342,135	S *	12/1993	Goldberger et al.	D24/129
5,356,369	A	10/1994	Yamasaki et al.		
5,360,413	A	11/1994	Leason et al.		
5,474,544	A	12/1995	Lynn		
5,501,426	A	3/1996	Atkinson et al.		
5,509,433	A	4/1996	Paradis		
5,533,708	A	7/1996	Atkinson et al.		
5,616,130	A	4/1997	Mayer		
5,632,735	A	5/1997	Wyatt et al.		
5,676,346	A	10/1997	Leinsing		
5,699,821	A	12/1997	Paradis		
5,730,418	A	3/1998	Feith et al.		
5,820,601	A	10/1998	Mayer		
6,036,171	A	3/2000	Weinheimer et al.		
6,039,302	A	3/2000	Cote et al.		

6,079,432	A	6/2000	Paradis		
6,171,287	B1	1/2001	Lynn et al.		
6,379,340	B1 *	4/2002	Zinger et al.	604/246
D478,662	S *	8/2003	Flinchbaugh	D24/129
D482,447	S *	11/2003	Harding et al.	D24/129
6,651,956	B2	11/2003	Miller		
6,991,215	B2	1/2006	Kiehne		
7,811,278	B2 *	10/2010	Knipple et al.	604/535
7,963,950	B2 *	6/2011	Madonia	604/246
D644,731	S *	9/2011	Fangrow, Jr.	D24/129
2001/0054423	A1 *	12/2001	Gray	128/205.13
2006/0252997	A1 *	11/2006	Wilk	600/237
2011/0082431	A1 *	4/2011	Burgess et al.	604/240
2011/0160679	A1 *	6/2011	Okiyama et al.	604/246
2011/0190733	A1 *	8/2011	D'Lima et al.	604/539

* cited by examiner

Primary Examiner — T. Chase Nelson

Assistant Examiner — Eric Goodman

(74) *Attorney, Agent, or Firm* — David S. Noskowicz;
Philips H. Burns, IV

(57) **CLAIM**

The ornamental design for a medical port, as shown and described.

DESCRIPTION

FIG. 1 is a rear, right, top perspective view of a medical port, illustrating an embodiment our new design;

FIG. 2 is a rear elevation view thereof;

FIG. 3 is a front elevation view thereof;

FIG. 4 is a right elevation view thereof;

FIG. 5 is a top plan view thereof; and,

FIG. 6 is a bottom plan view thereof.

The dashed lines indicate unclaimed subject matter by outline.

The broken line showing is included for the purpose of illustrating portions of the article and forms no part of the claimed design. The broken lines which define the bounds of the claimed design form no part thereof.

1 Claim, 2 Drawing Sheets

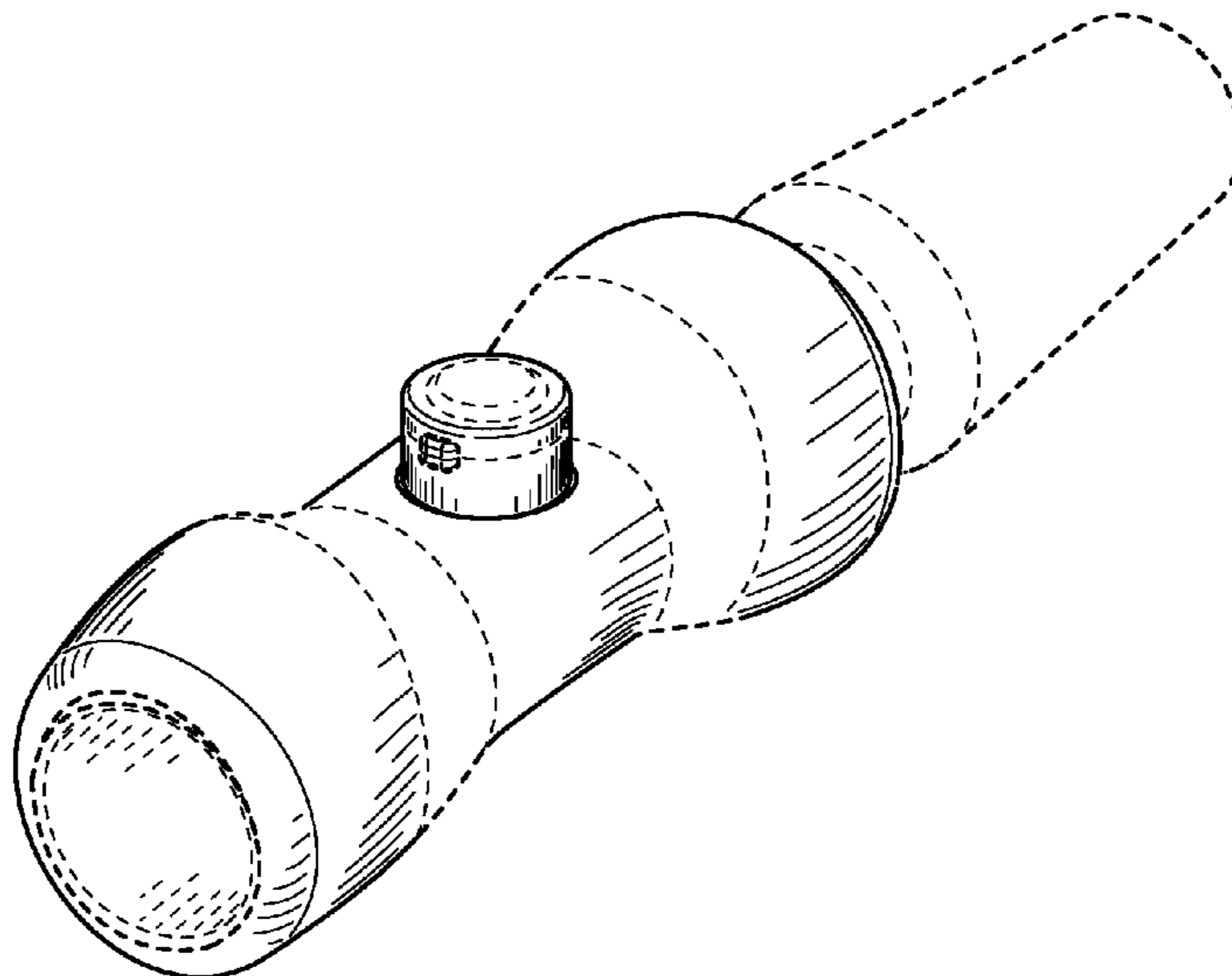

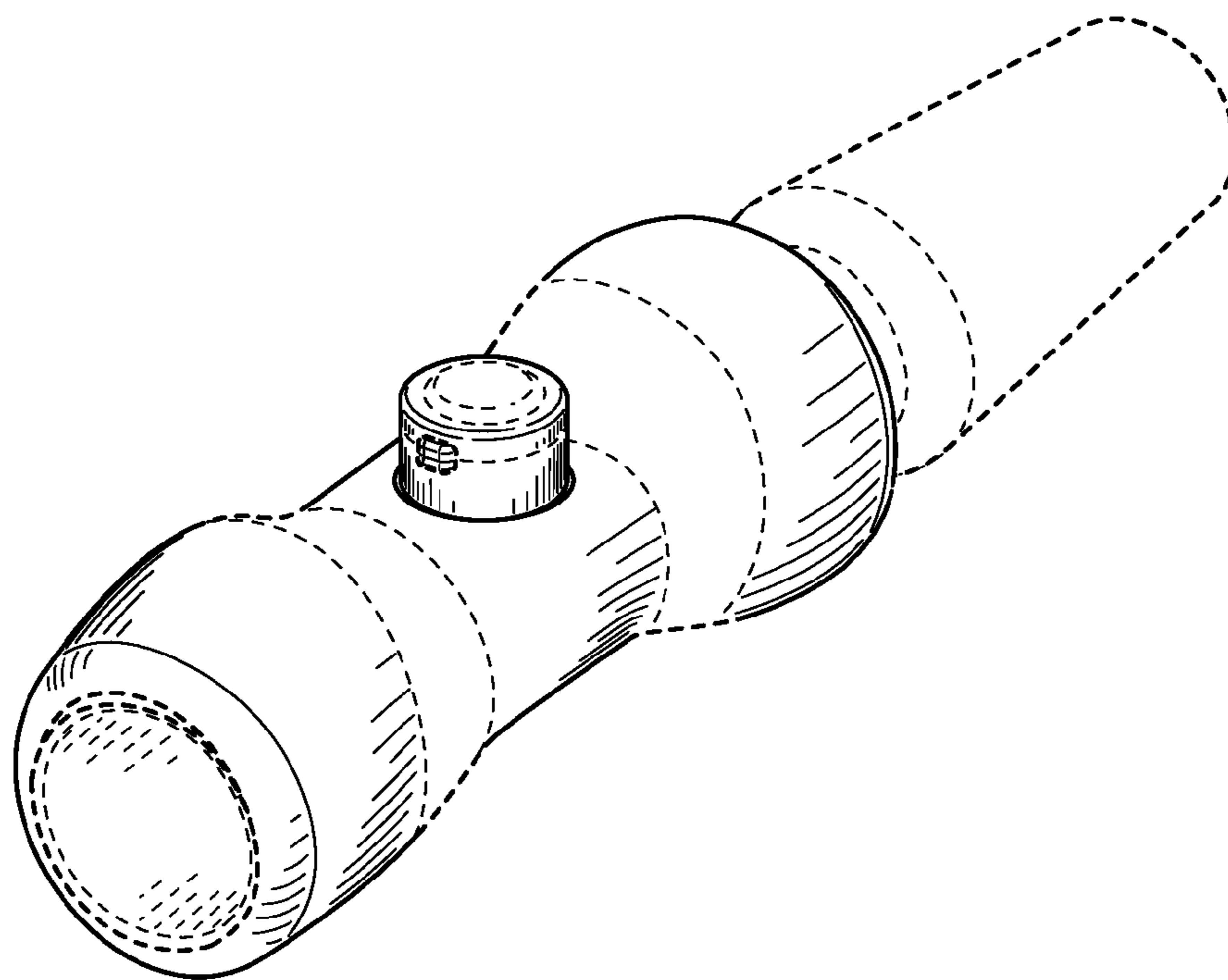

FIG. 1

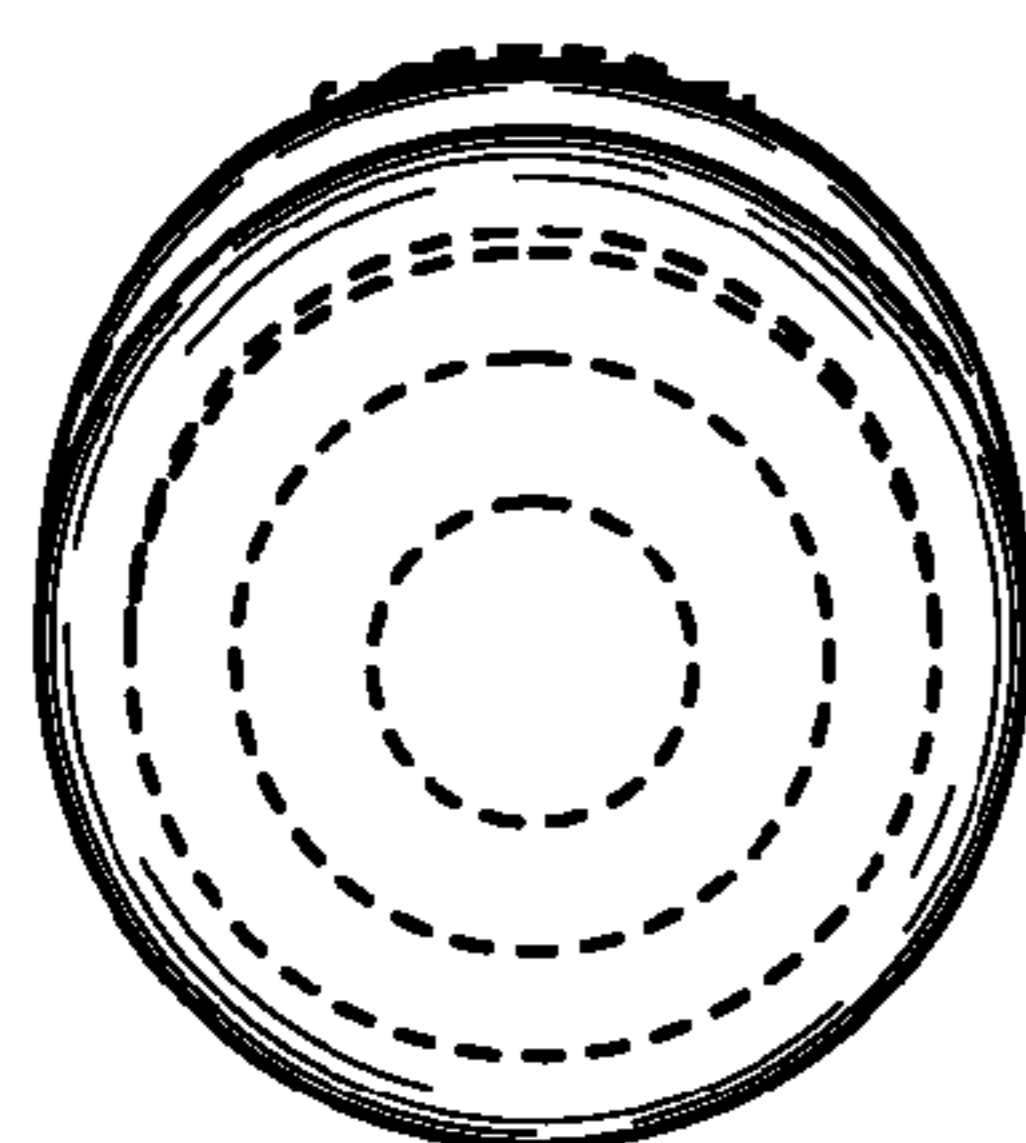

FIG. 2

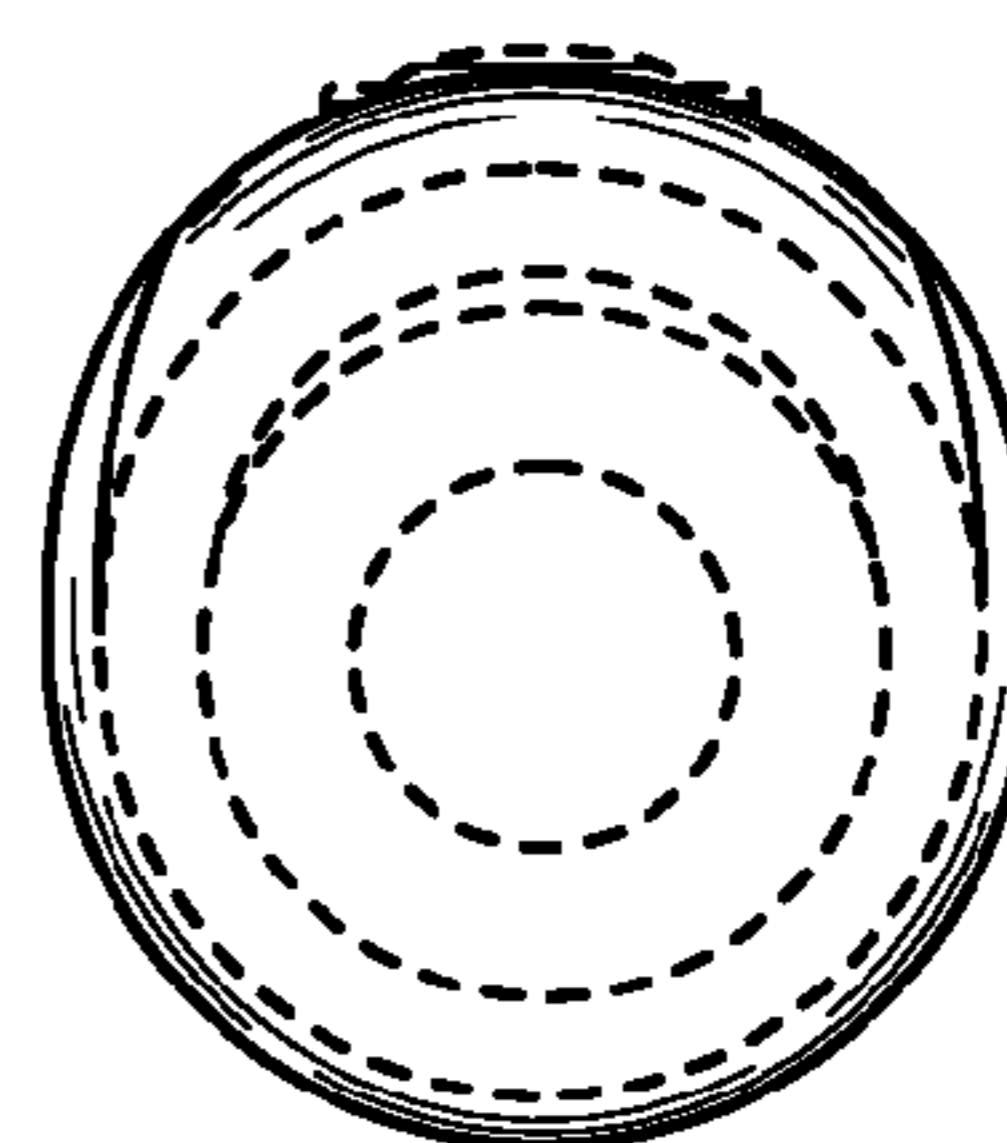

FIG. 3

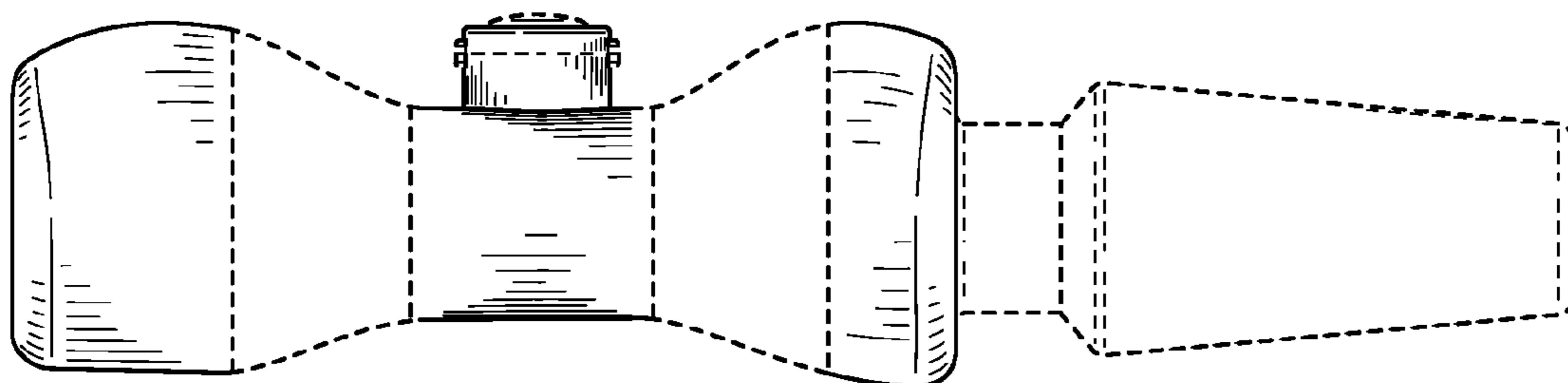

FIG. 4

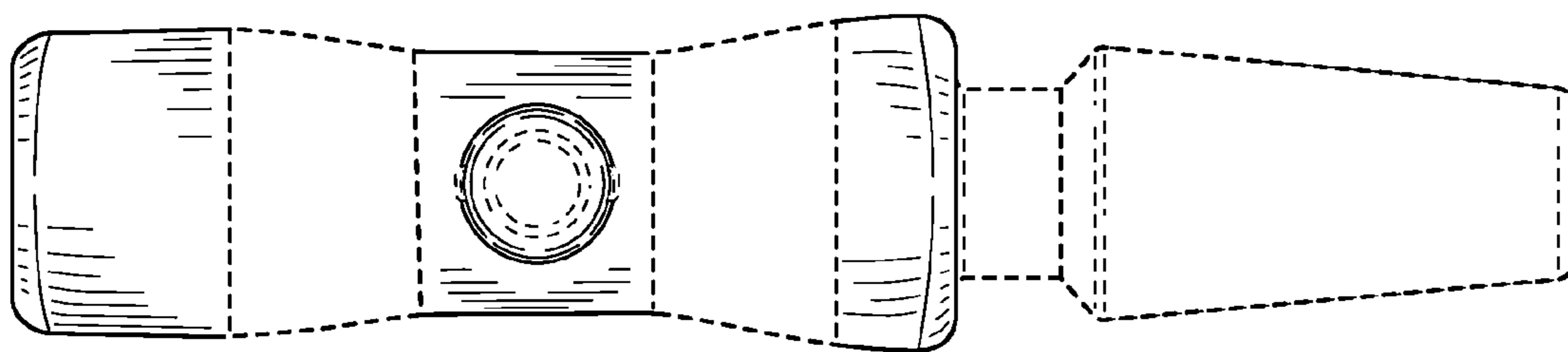

FIG. 5

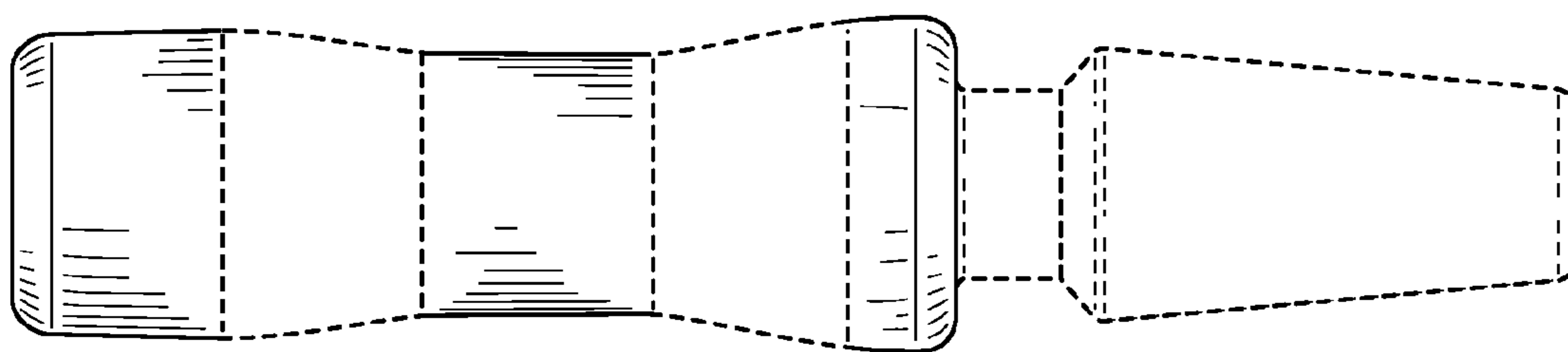

FIG. 6