



US00D657005S

(12) **United States Design Patent**  
**Zahornacky**

(10) **Patent No.:** **US D657,005 S**

(45) **Date of Patent:** **\*\* Apr. 3, 2012**

(54) **ADJUSTABLE TRANSFORMER FOR A MODEL VEHICLE**

(75) Inventor: **Jon Zahornacky**, Santa Clara, CA (US)

(73) Assignee: **Lionel L.L.C.**, Chesterfield, MI (US)

(\*\*) Term: **14 Years**

(21) Appl. No.: **29/386,403**

(22) Filed: **Feb. 28, 2011**

(51) **LOC (9) Cl.** ..... **21-01**

(52) **U.S. Cl.** ..... **D21/566**

(58) **Field of Classification Search** ..... D21/324,  
D21/329, 333, 434, 477, 552, 559, 560, 566;  
D14/400, 401, 454, 217, 218, 358, 155; D13/158,  
D13/169; D12/98; 463/6, 7, 37, 38, 39,  
463/46, 47; 345/156; 446/454-456; 300/315,  
300/329, 332, 335, 339, 457, 533; 307/403  
See application file for complete search history.

(56) **References Cited**

**U.S. PATENT DOCUMENTS**

D160,765 S *	11/1950	Bonanno	.....	D21/566
D179,156 S *	11/1956	Patane	.....	D21/566
D185,647 S *	7/1959	Rabinow	.....	D21/566
D187,603 S *	4/1960	Bonanno	.....	D21/566
D206,671 S *	1/1967	Gilbert	.....	D21/566
D209,151 S *	11/1967	Jones	.....	D21/561
D265,476 S *	7/1982	Zizza	.....	D21/566

D314,994 S *	2/1991	Poulsen	.....	D21/566
D433,077 S *	10/2000	Yamazaki	.....	D21/477
D453,540 S *	2/2002	Sullivan	.....	D21/566
6,371,829 B1 *	4/2002	Kato et al.	.....	446/456
D509,266 S *	9/2005	Golliher	.....	D21/566
D557,752 S *	12/2007	Martino et al.	.....	D21/566

\* cited by examiner

*Primary Examiner* — Cynthia M Chin

(74) *Attorney, Agent, or Firm* — O'Melveny & Myers LLP

(57) **CLAIM**

The ornamental design for an adjustable transformer for a model vehicle, as shown and described.

**DESCRIPTION**

FIG. 1 is a front view of an adjustable transformer for a model vehicle in accordance with the invention;  
 FIG. 2 is a back view of the adjustable transformer for a model vehicle;  
 FIG. 3 is a right side view of the adjustable transformer for a model vehicle;  
 FIG. 4 is a left side view of the adjustable transformer for a model vehicle;  
 FIG. 5 is a top view of the adjustable transformer for a model vehicle; and,  
 FIG. 6 is a bottom view of the adjustable transformer for a model vehicle.

The broken lines in the drawings represent unclaimed environmental subject matter.

**1 Claim, 6 Drawing Sheets**

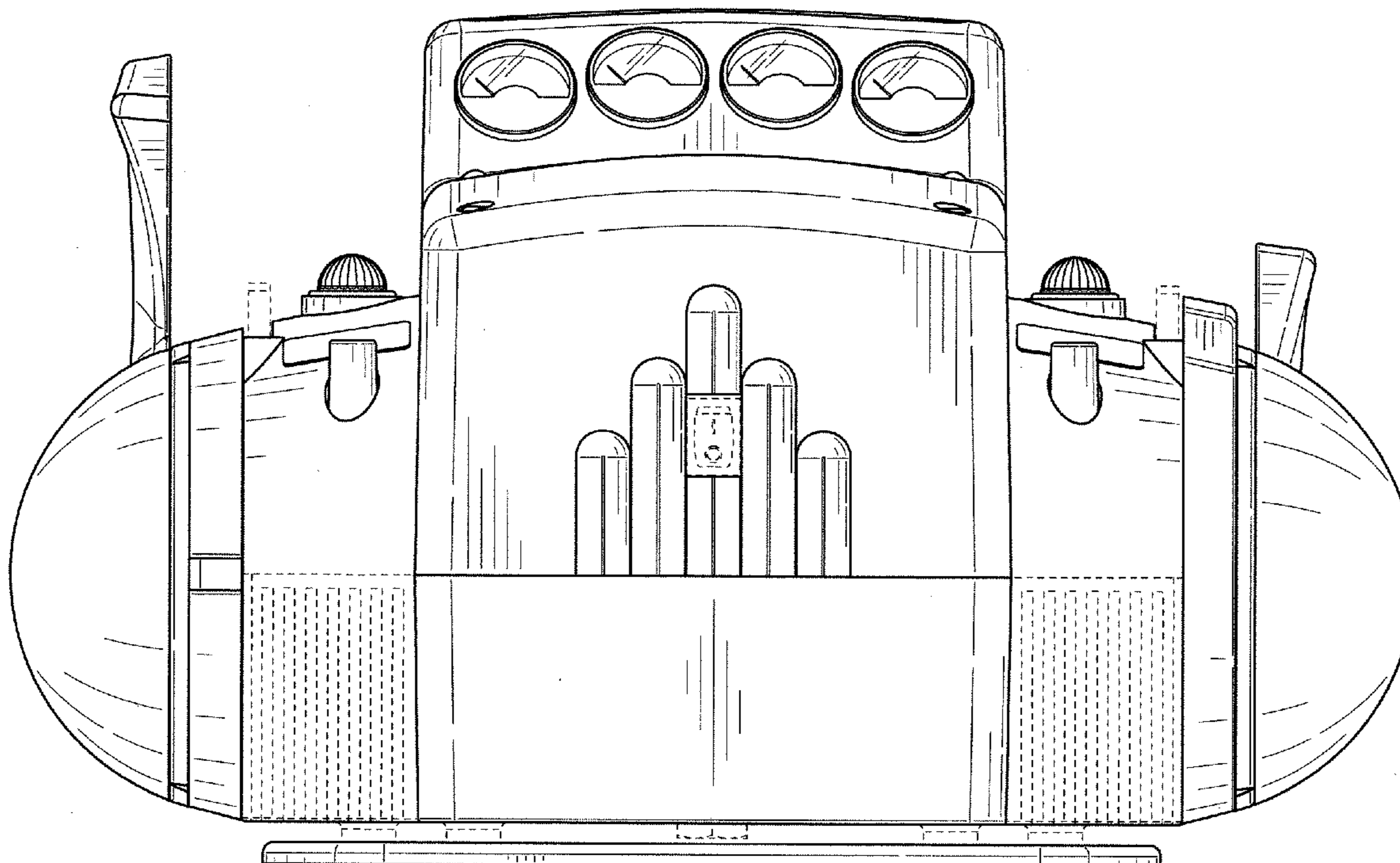

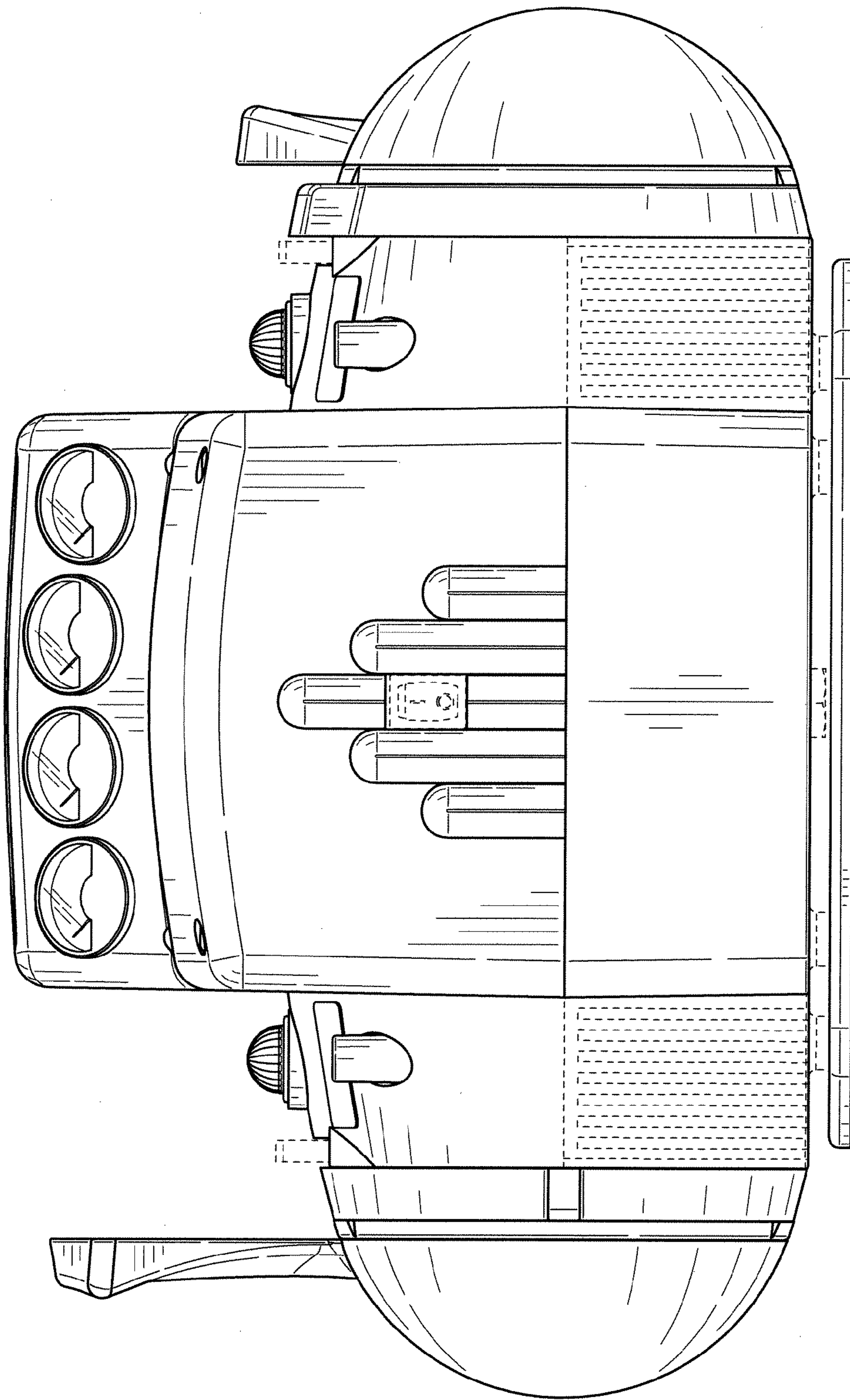

FIG. 1

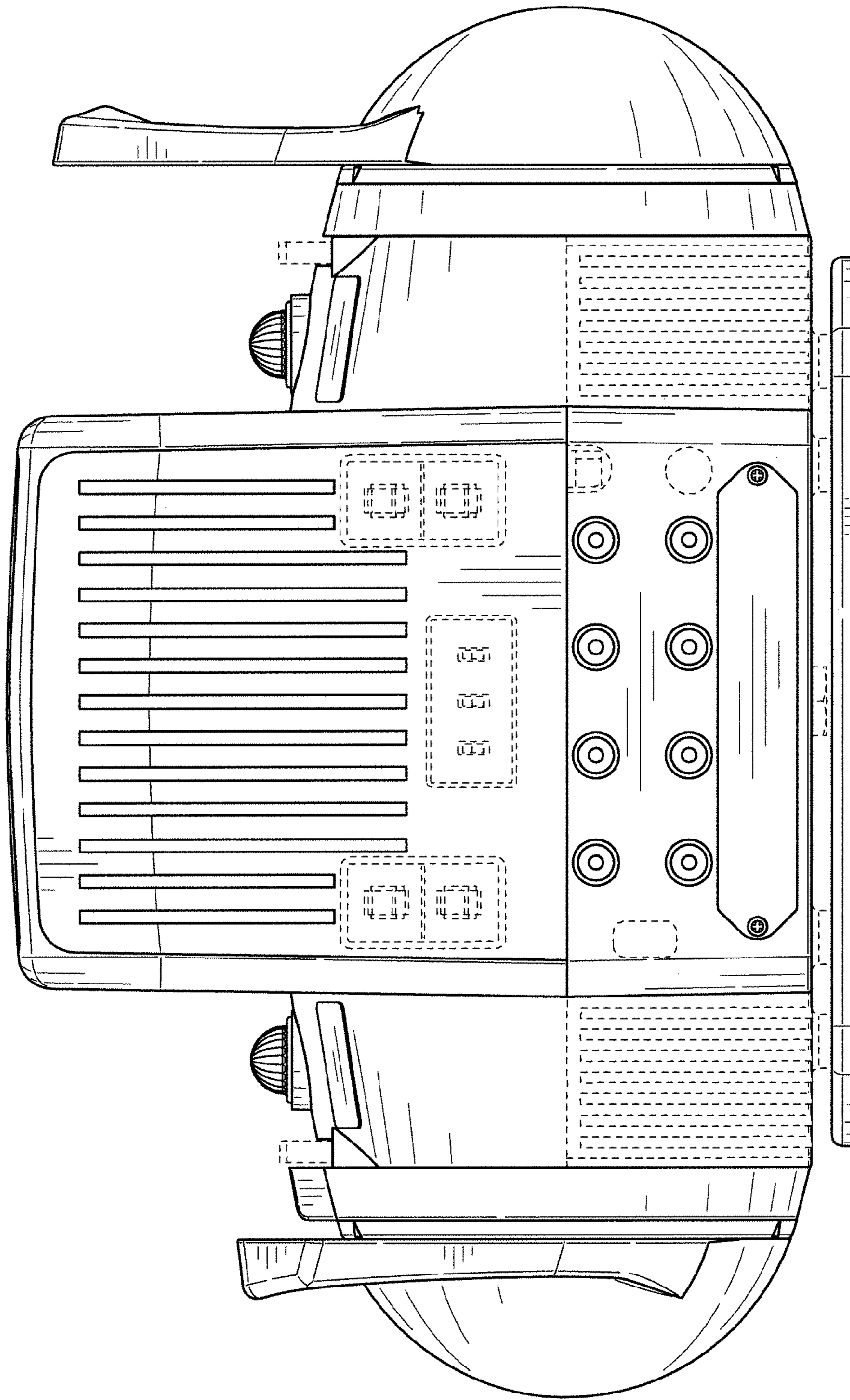

FIG. 2

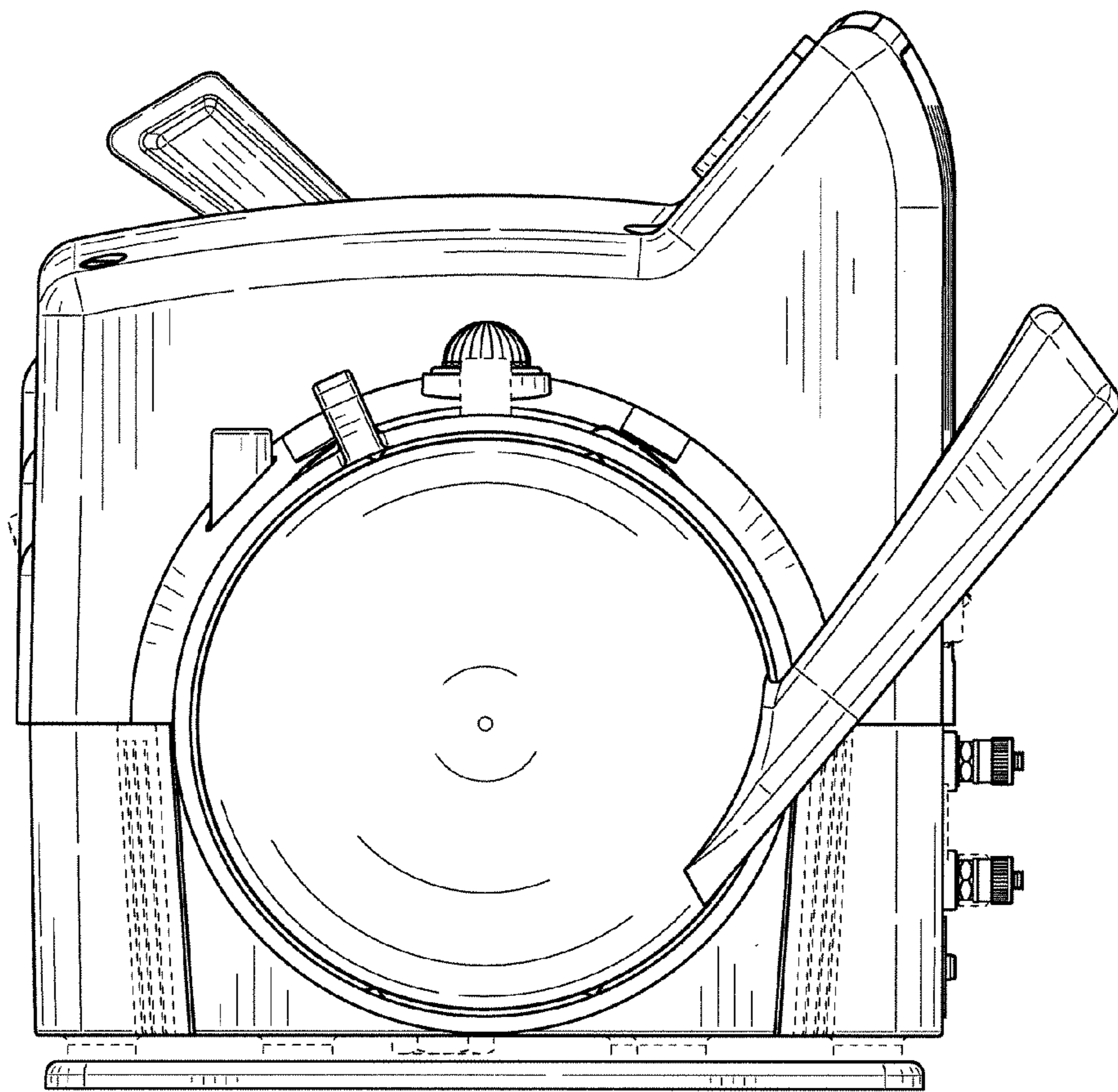

FIG. 3

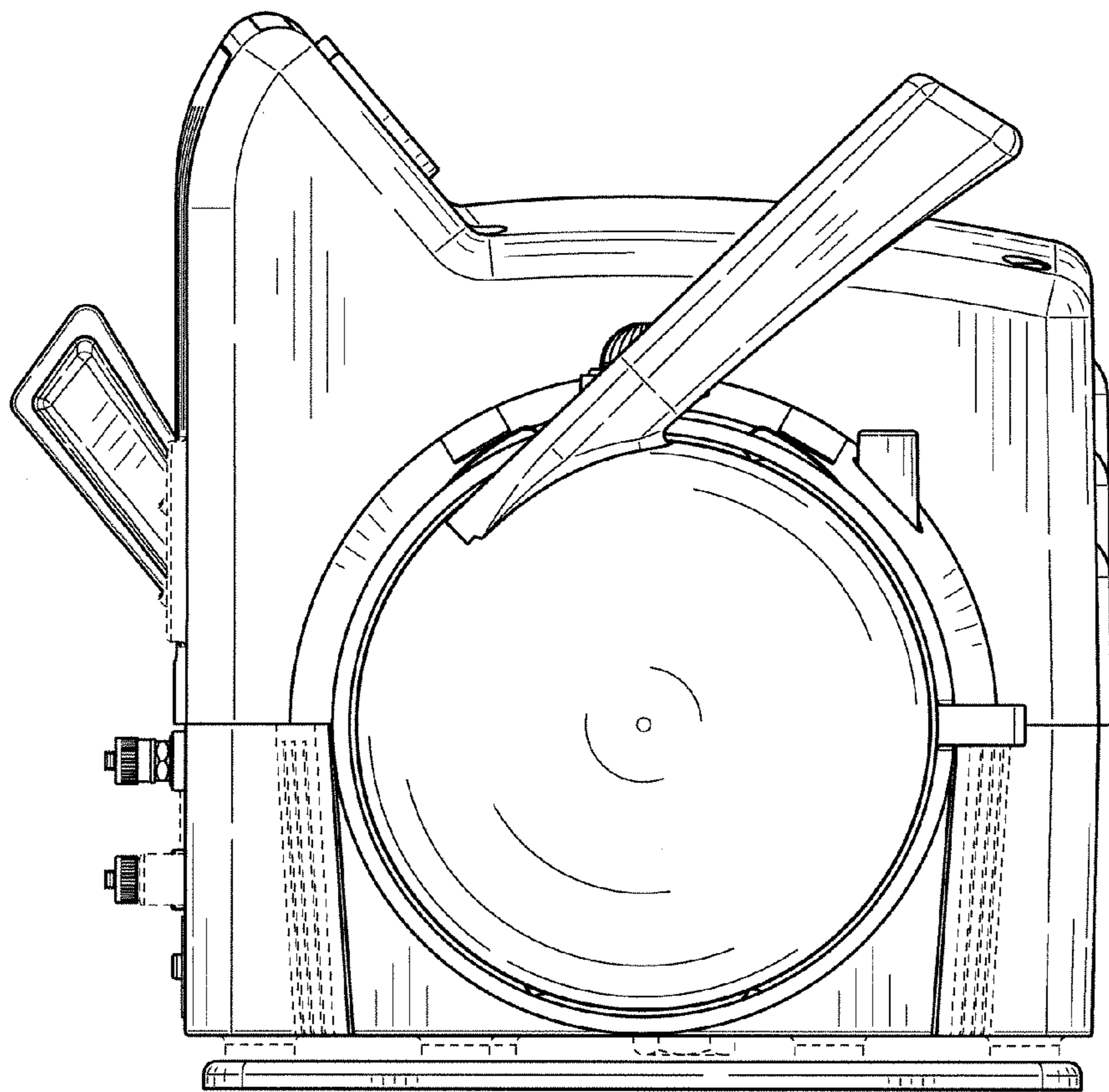

FIG. 4

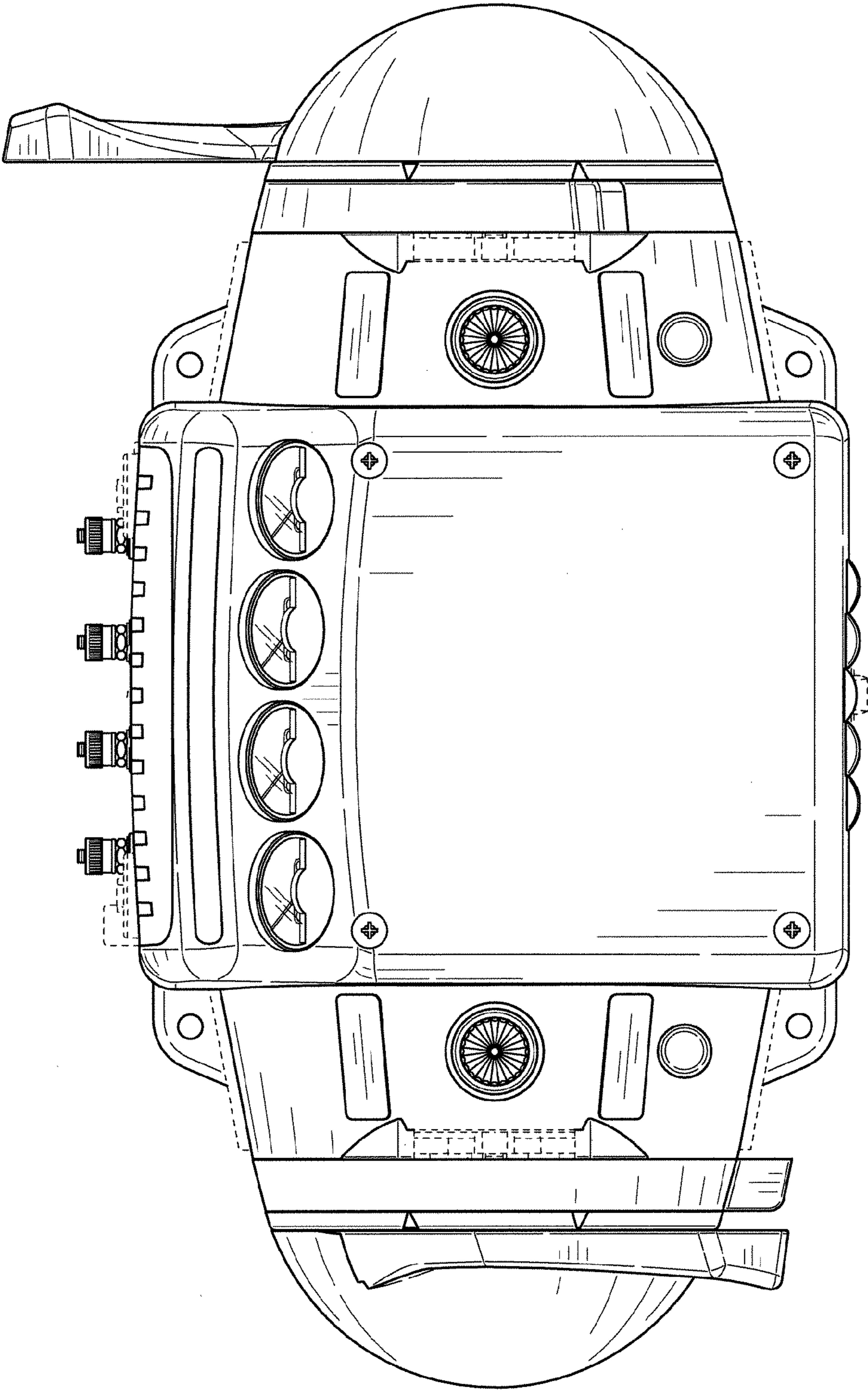

FIG. 5

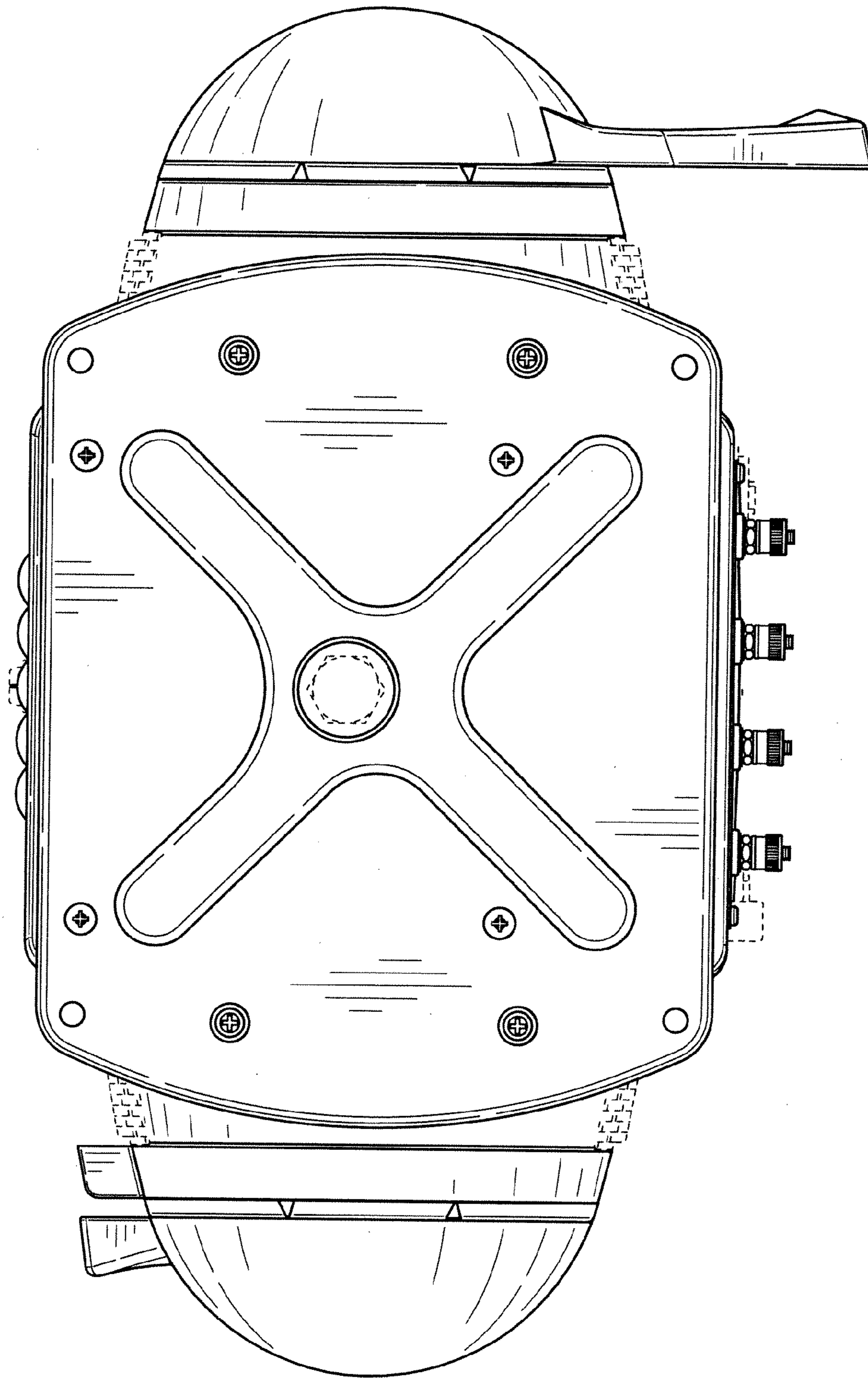

FIG. 6