



US00D656999S

(12) **United States Design Patent**
Frederick

(10) **Patent No.:** **US D656,999 S**

(45) **Date of Patent:** **** Apr. 3, 2012**

(54) **HELICOPTER FUSELAGE FRAME**

(76) Inventor: **David Frederick**, San Diego, CA (US)

(**) Term: **14 Years**

(21) Appl. No.: **29/351,193**

(22) Filed: **Dec. 1, 2009**

(51) **LOC (9) Cl.** **21-01**

(52) **U.S. Cl.** **D21/453; D13/112**

(58) **Field of Classification Search** D12/333,
D12/342, 34, 453; D13/113, 118, 184, 199;
D1/440, 441, 442; 244/36, 119, 120, 121;
446/34, 35, 36

See application file for complete search history.

(56) **References Cited**

U.S. PATENT DOCUMENTS

1,186,875	A *	6/1916	Barton	244/17.21
1,246,015	A *	11/1917	Curtiss	244/54
2,811,323	A *	10/1957	Rethorst	244/2
2,973,923	A *	3/1961	Szyncer	244/17.11
5,377,934	A *	1/1995	Hill	244/17.11
6,126,113	A *	10/2000	Navickas	244/120
6,142,419	A	11/2000	Arlton	
6,604,710	B2 *	8/2003	Ohmer et al.	244/119
7,168,657	B2	1/2007	Chen	
D585,370	S	1/2009	Tu	
7,891,608	B2 *	2/2011	Rawdon et al.	244/119
2006/0266880	A1	11/2006	Chen	
2007/0178798	A1	8/2007	Lai	
2010/0323579	A1 *	12/2010	Liang et al.	446/36

FOREIGN PATENT DOCUMENTS

TW	M284423	1/2006
TW	M284424	1/2006
TW	M296074	8/2006
TW	M300135	11/2006

* cited by examiner

Primary Examiner — Karen E Eldridge Powers

(74) *Attorney, Agent, or Firm* — Knobbe Martens Olson & Bear LLP

(57) **CLAIM**

The ornamental design for a helicopter fuselage frame, as shown and described.

DESCRIPTION

FIG. 1 is a first perspective view of an embodiment of a helicopter fuselage frame.

FIG. 2 is a second perspective view of an embodiment of a helicopter fuselage frame.

FIG. 3 is a top plan view of an embodiment of a helicopter fuselage frame.

FIG. 4 is a bottom plan view of an embodiment of a helicopter fuselage frame.

FIG. 5 is a front elevational view of an embodiment of a helicopter fuselage frame.

FIG. 6 is a rear elevational view of an embodiment of a helicopter fuselage frame.

FIG. 7 is a right side elevational view of an embodiment of a helicopter fuselage frame; and,

FIG. 8 is a left side elevational view of an embodiment of a helicopter fuselage frame.

1 Claim, 4 Drawing Sheets

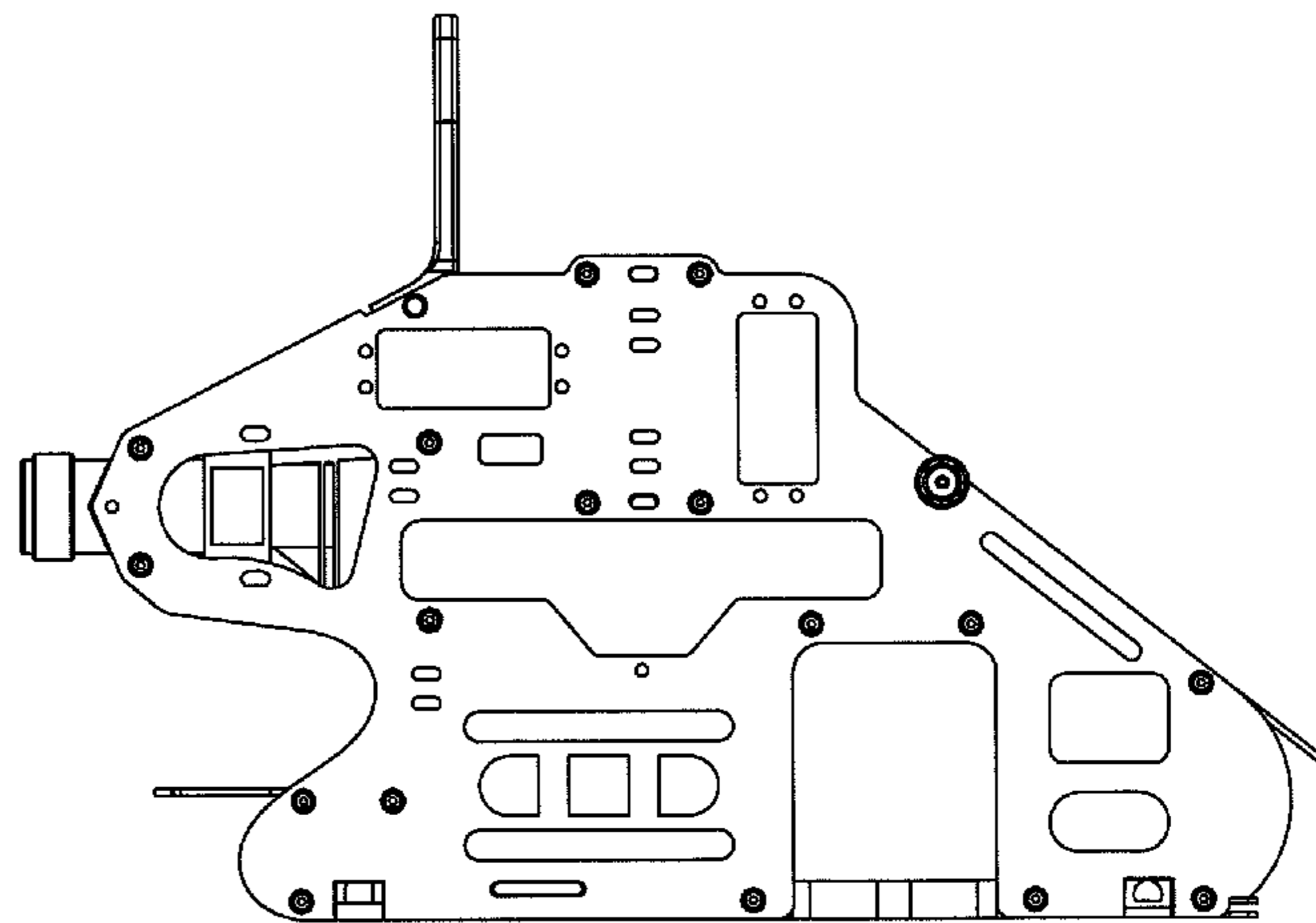
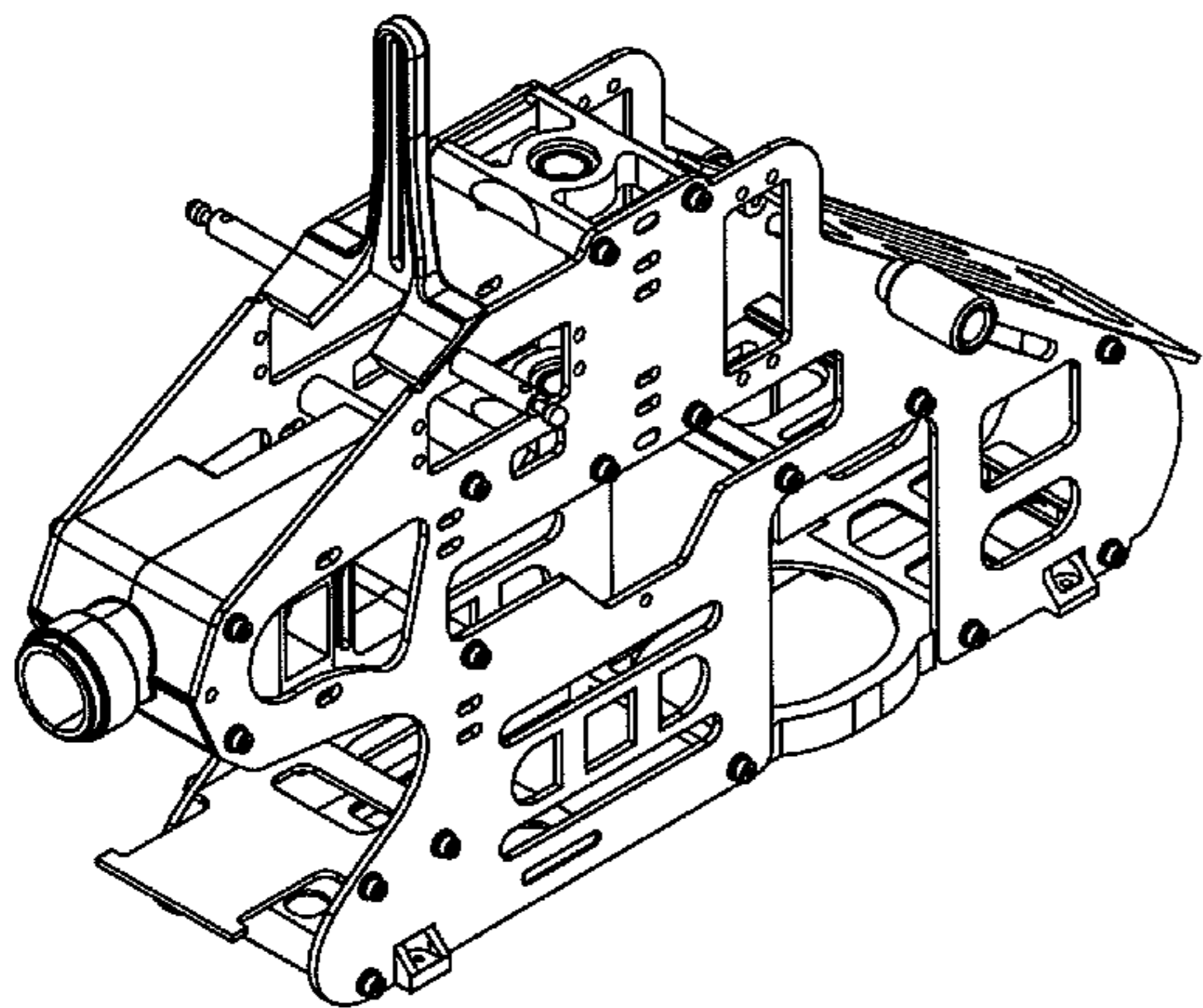

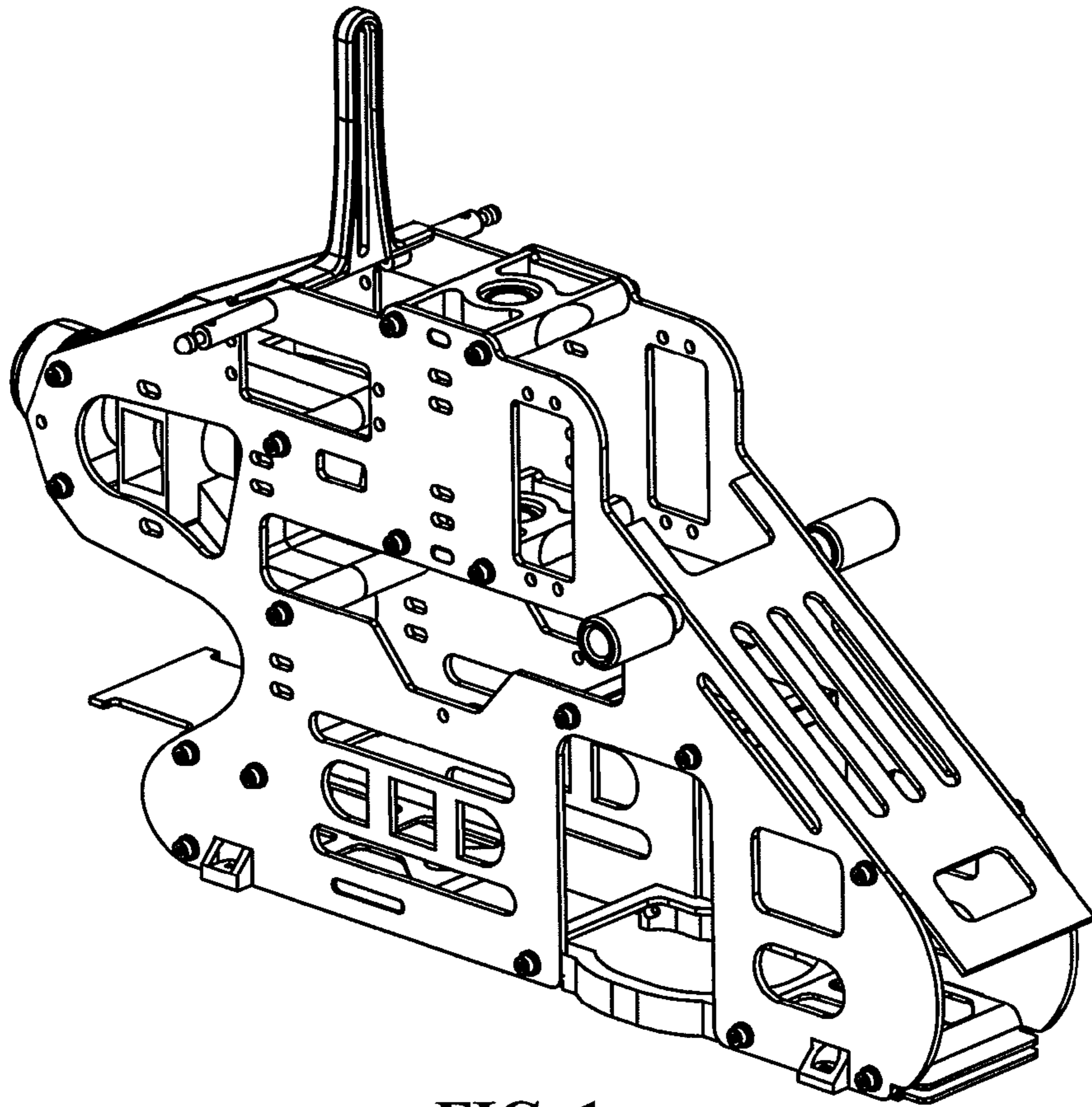

FIG. 1

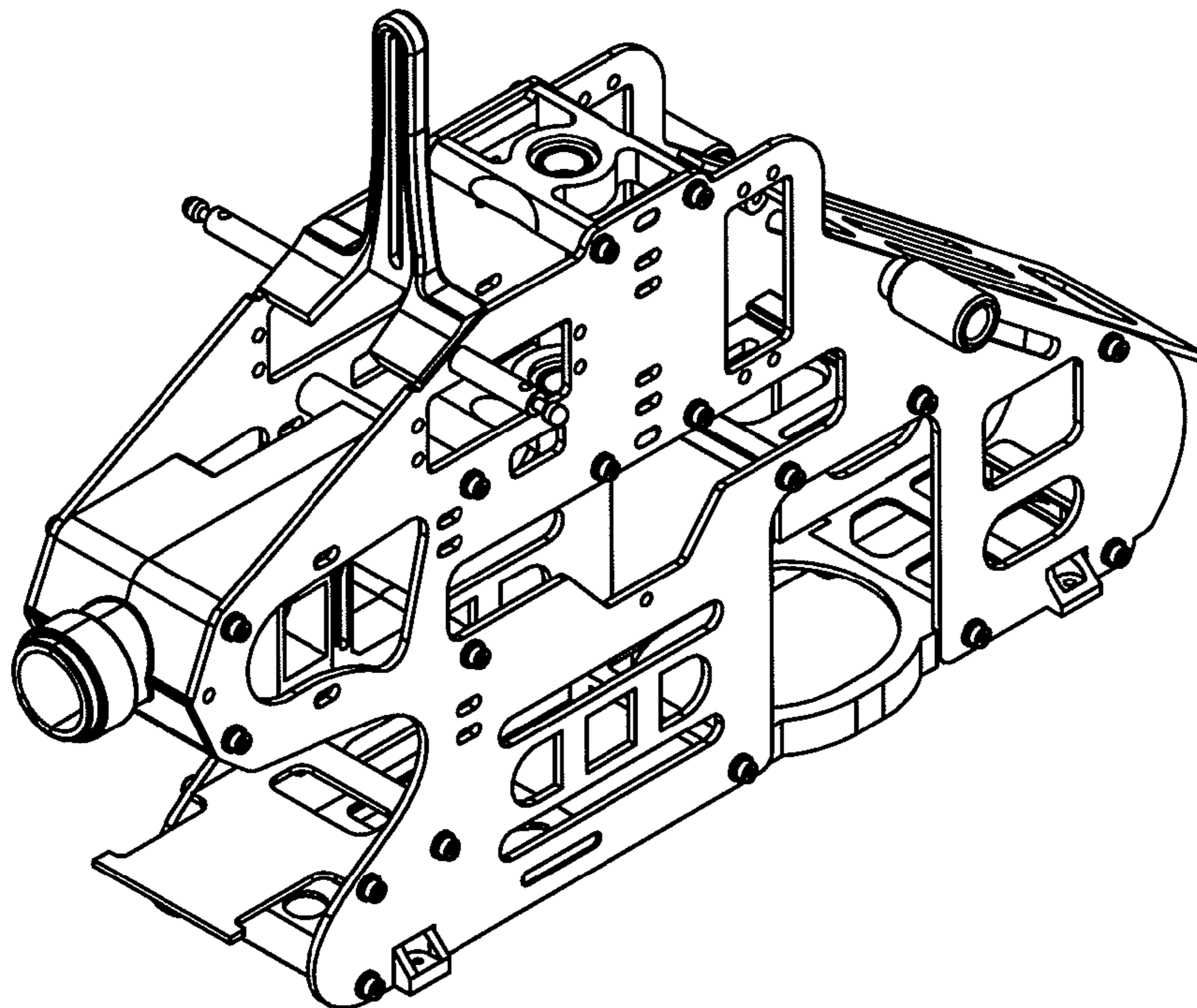

FIG. 2

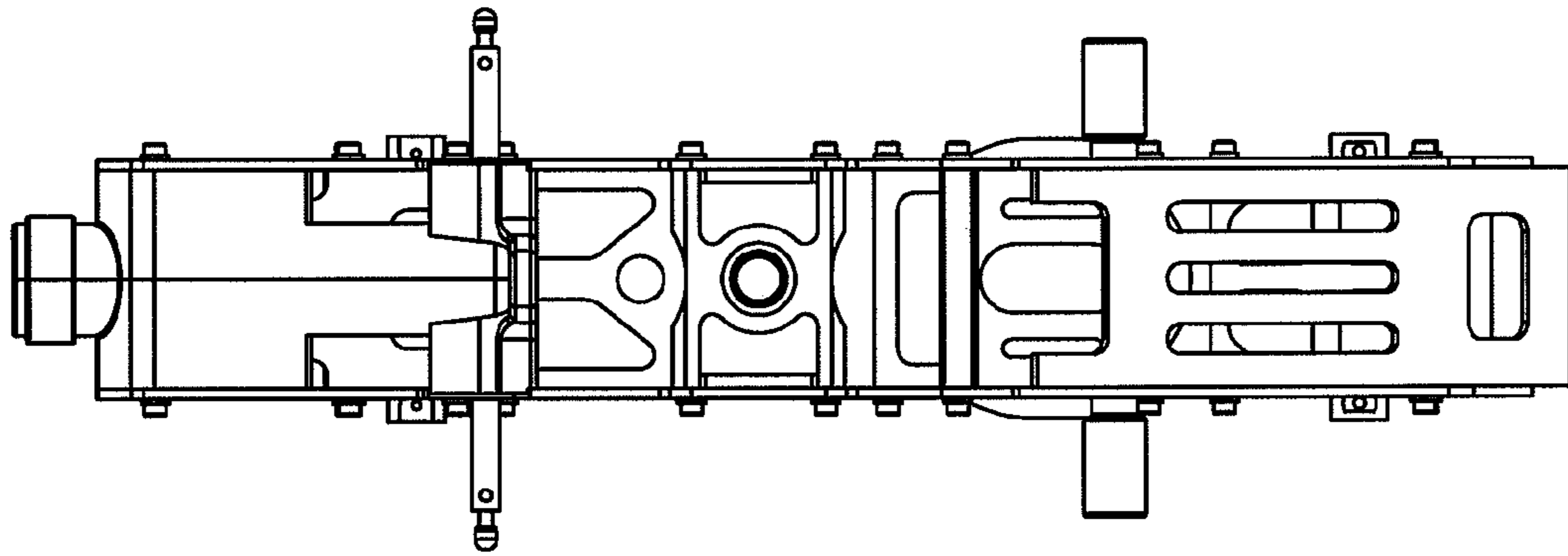

FIG. 3

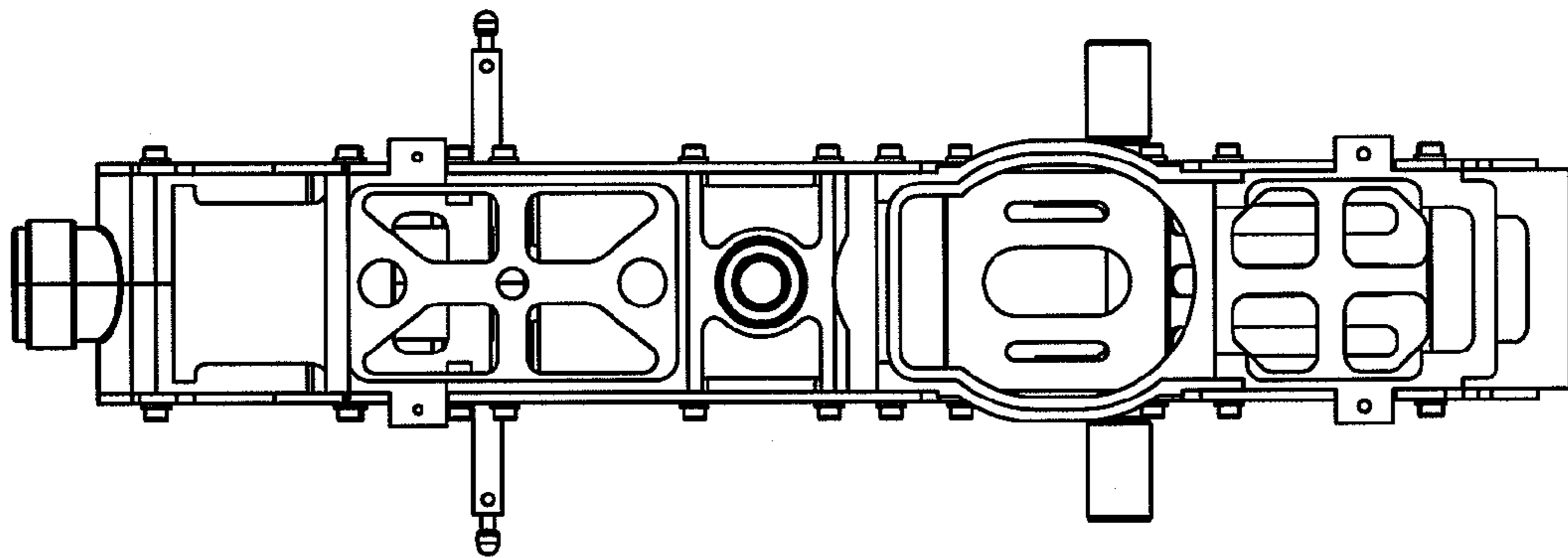

FIG. 4

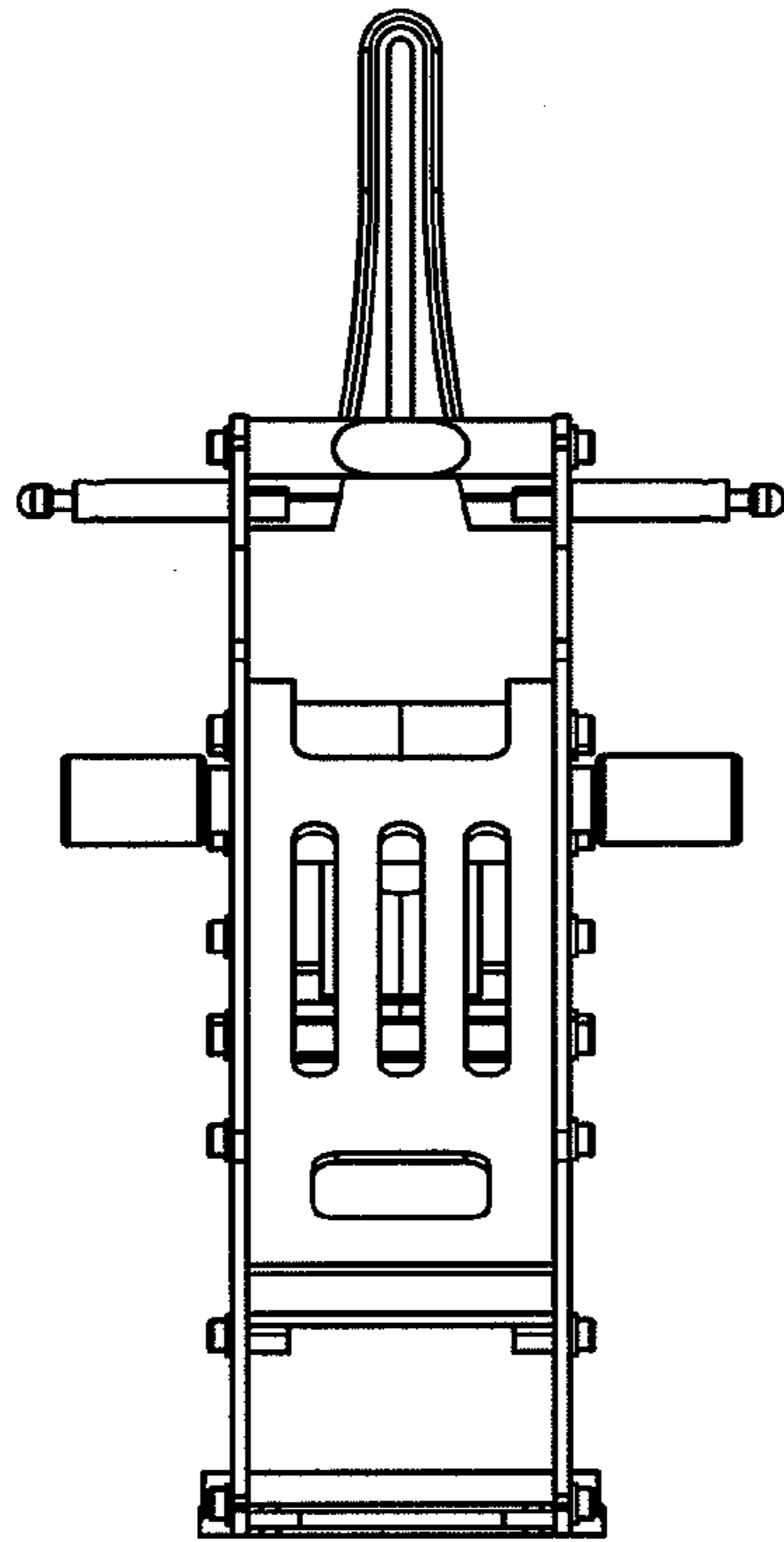

FIG. 5

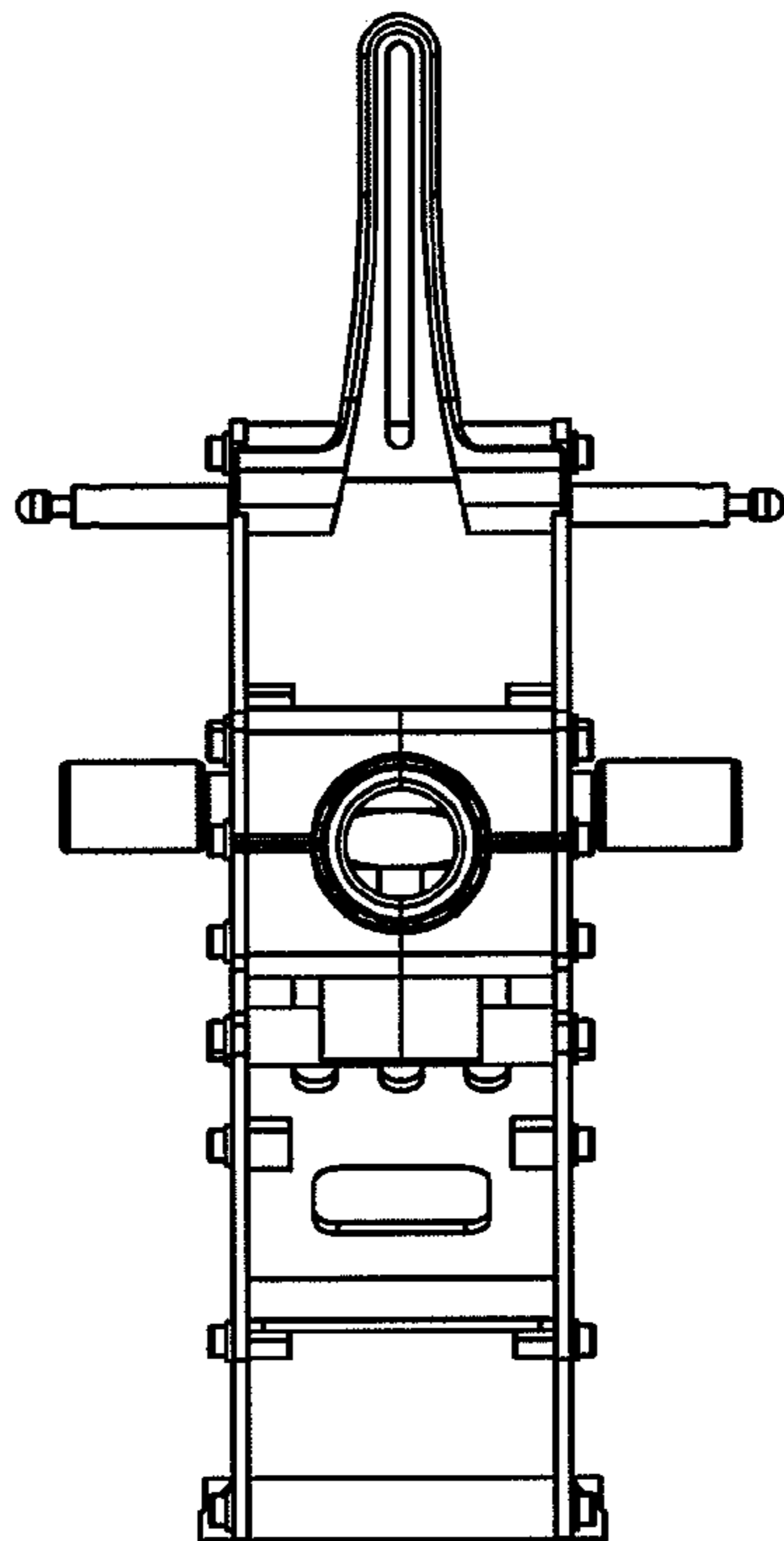

FIG. 6

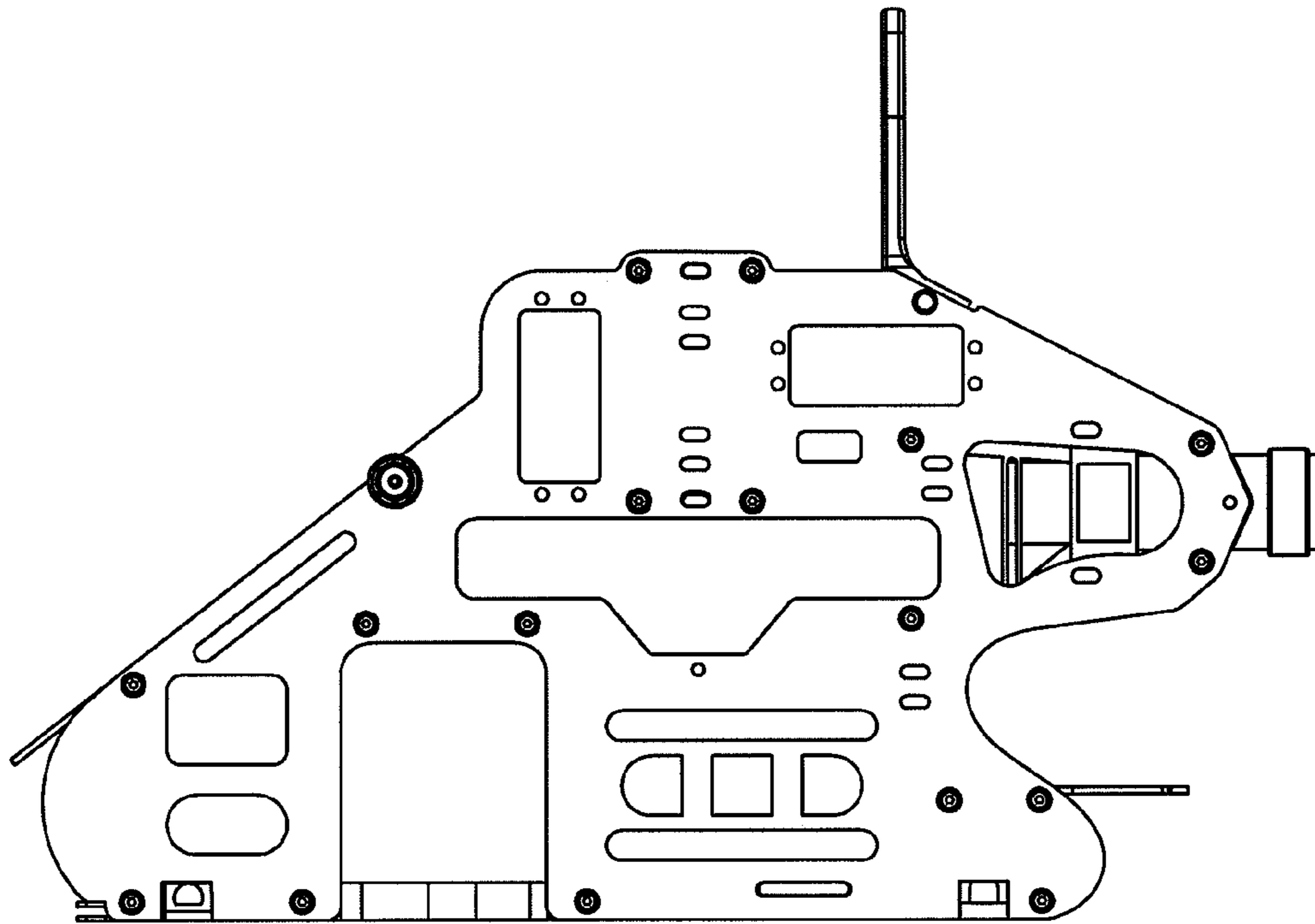

FIG. 7

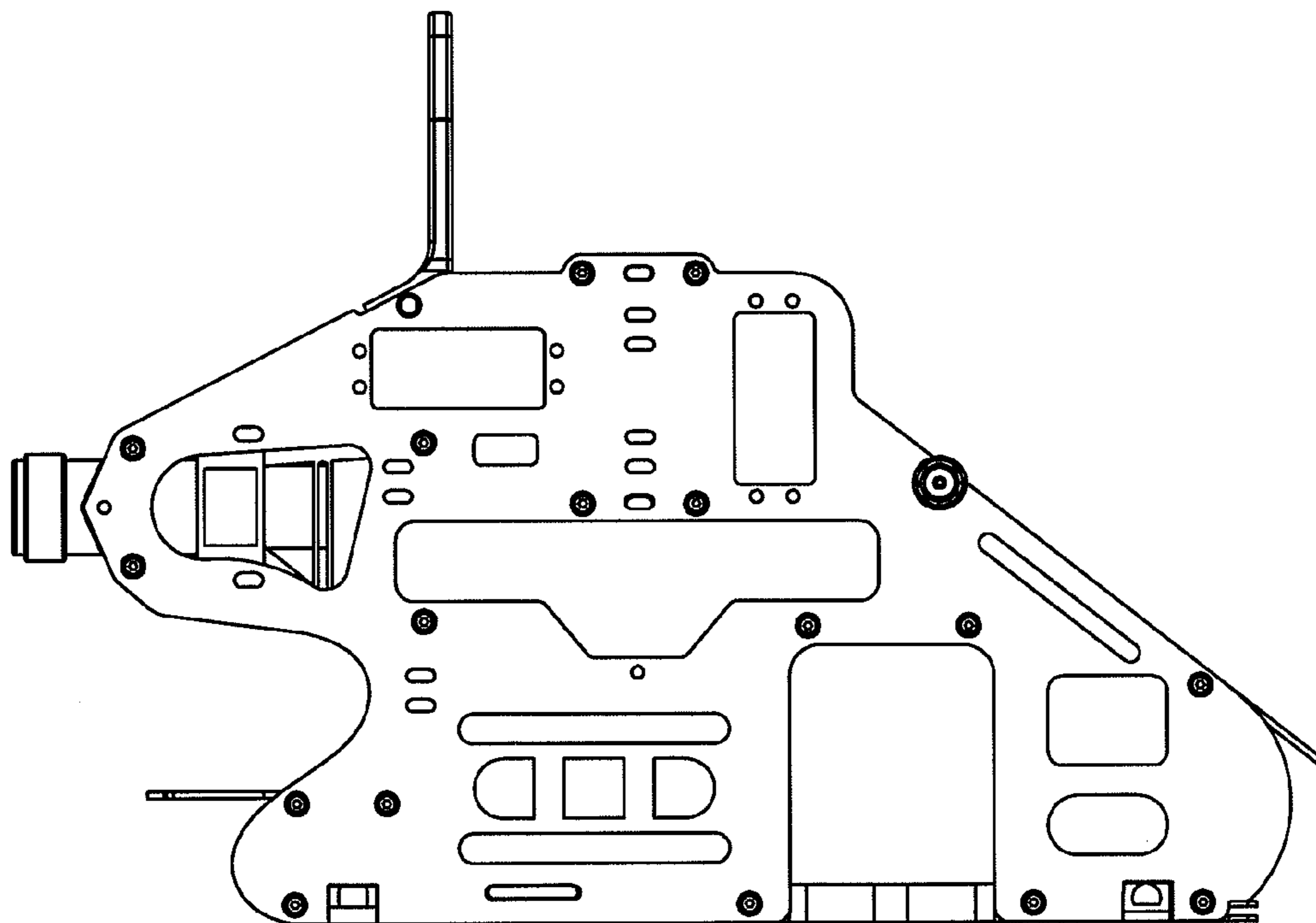

FIG. 8