



US00D656907S

(12) **United States Design Patent**  
**Wu et al.**

(10) **Patent No.:** **US D656,907 S**  
(45) **Date of Patent:** **\*\* Apr. 3, 2012**

(54) **LED PACKAGE**

(75) Inventors: **Chung-Chan Wu**, Taipei (TW);  
**Yu-Fang Peng**, New Taipei (TW)

(73) Assignees: **Silitek Electronic (Guangzhou) Co., Ltd.**, Guangzhou (CN); **Lite-On Technology Corporation**, Taipei (TW)

(\*\*) Term: **14 Years**

(21) Appl. No.: **29/394,660**

(22) Filed: **Jun. 20, 2011**

(51) **LOC (9) Cl.** ..... **13-03**

(52) **U.S. Cl.** ..... **D13/180**

(58) **Field of Classification Search** ..... D13/180;  
D26/1, 2; 257/79, 80, 81, 88, 89, 95, 98,  
257/99, 100, E33.058; 313/483, 498, 500;  
362/555, 800

See application file for complete search history.

(56) **References Cited**

U.S. PATENT DOCUMENTS

7,199,452 B2 \* 4/2007 Takase ..... 257/660  
D609,654 S \* 2/2010 Hsieh ..... D13/180  
7,701,050 B2 \* 4/2010 Chen et al. .... 257/693

D619,111 S \* 7/2010 Wu et al. .... D13/180  
7,808,085 B2 \* 10/2010 Ozaki et al. .... 257/667  
2008/0272383 A1 \* 11/2008 Loh ..... 257/98

\* cited by examiner

*Primary Examiner* — Selina Sikder

(74) *Attorney, Agent, or Firm* — Li & Cai Intellectual Property (USA) Office

(57) **CLAIM**

The ornamental design for a “LED package,” as shown and described.

**DESCRIPTION**

FIG. 1 is a perspective view of a “LED package” showing my new design;  
FIG. 2 is a front view thereof;  
FIG. 3 is a rear view thereof;  
FIG. 4 is a left side view thereof;  
FIG. 5 is a right side view thereof;  
FIG. 6 is a top view thereof;  
FIG. 7 is a bottom view thereof; and,  
FIG. 8 is a perspective view viewed from another visual angle.

The dashed lines in the drawings are for illustrative purpose only and form no part of the claimed design.

**1 Claim, 5 Drawing Sheets**

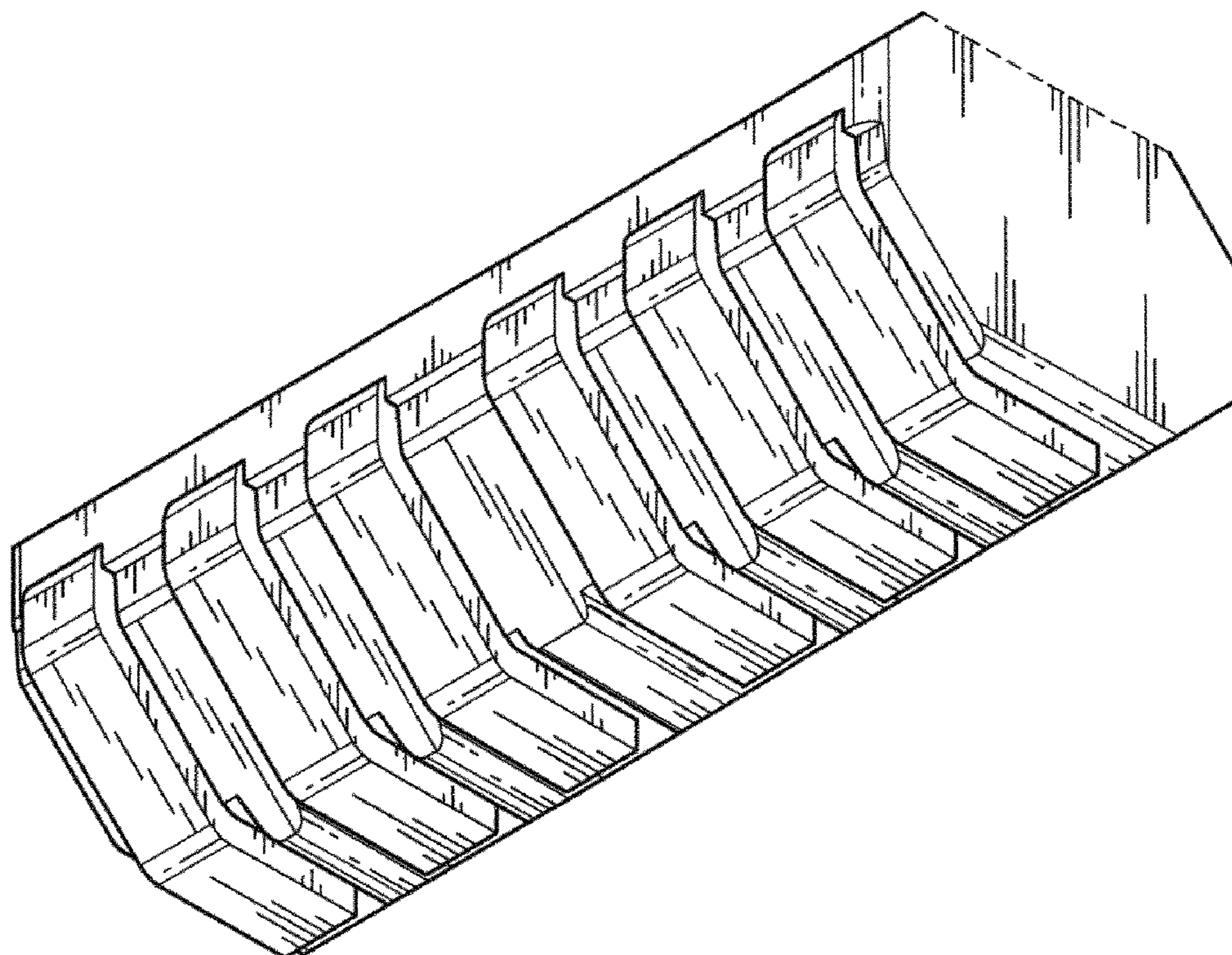

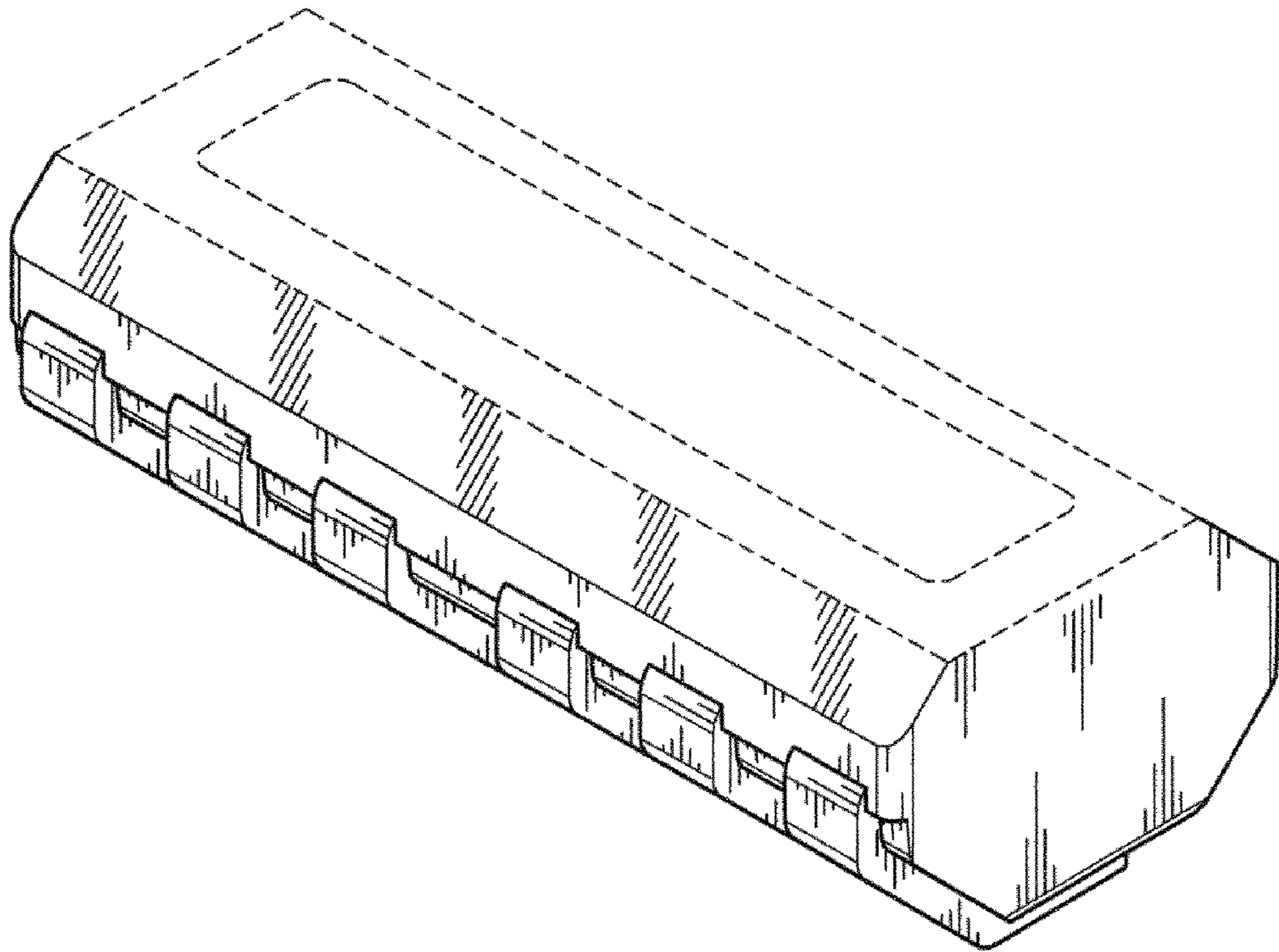

FIG. 1

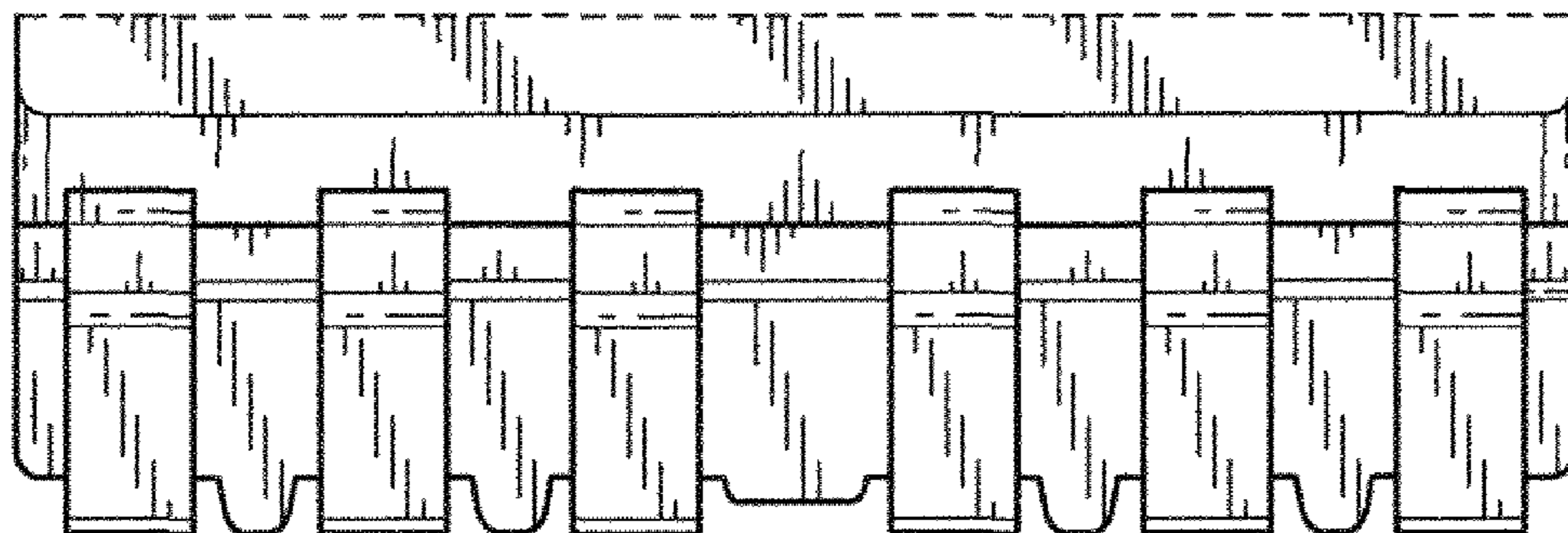

FIG. 2

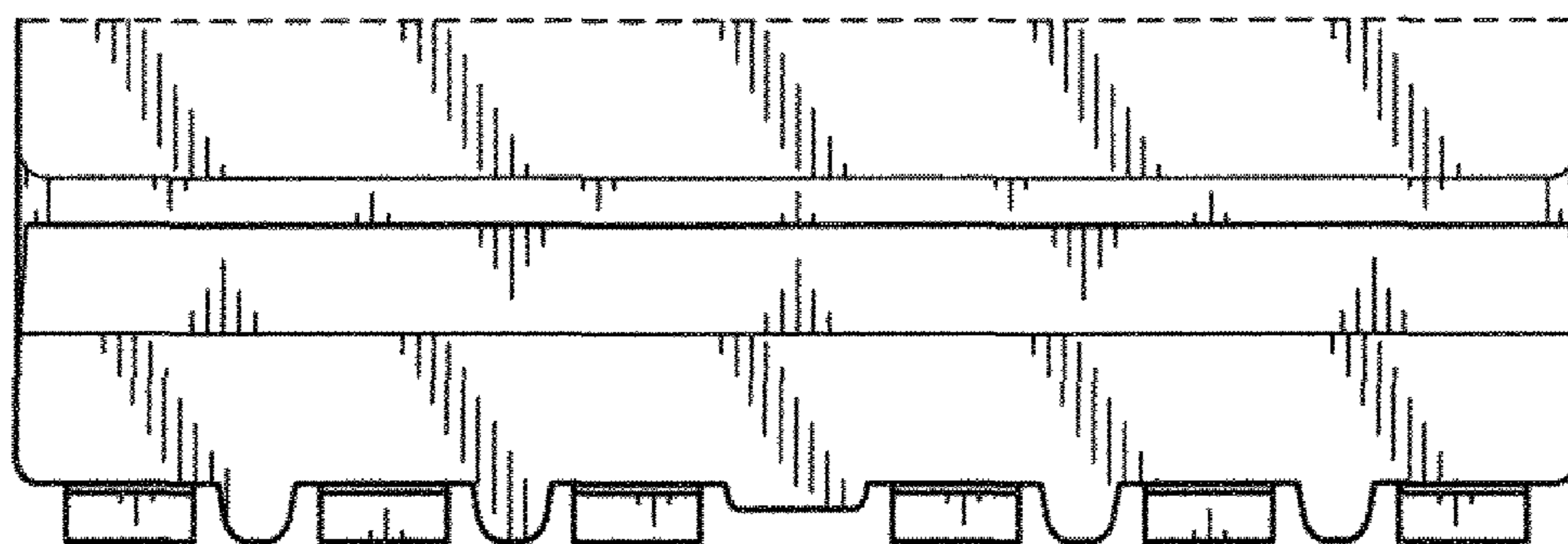

FIG. 3

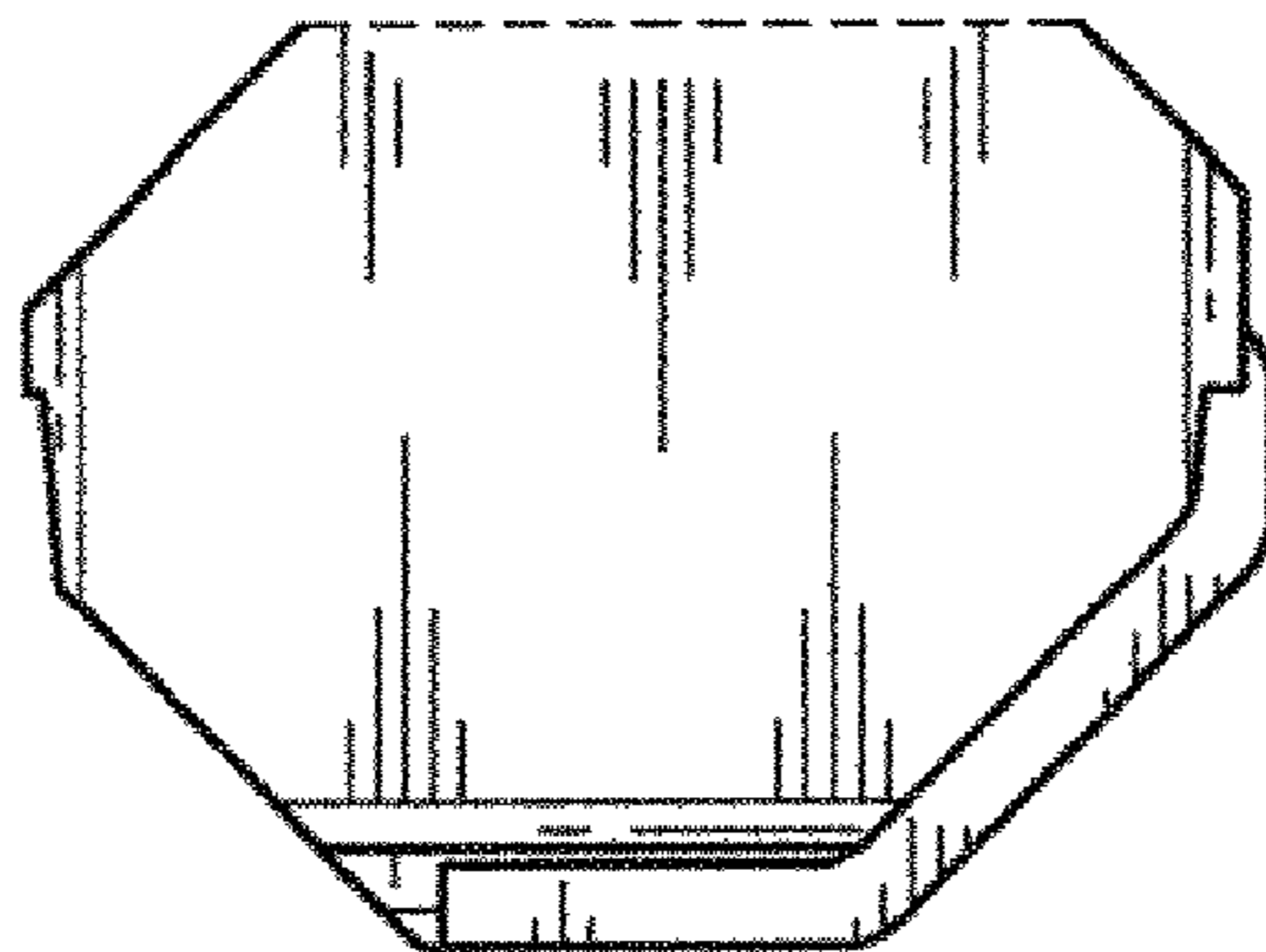

FIG. 4

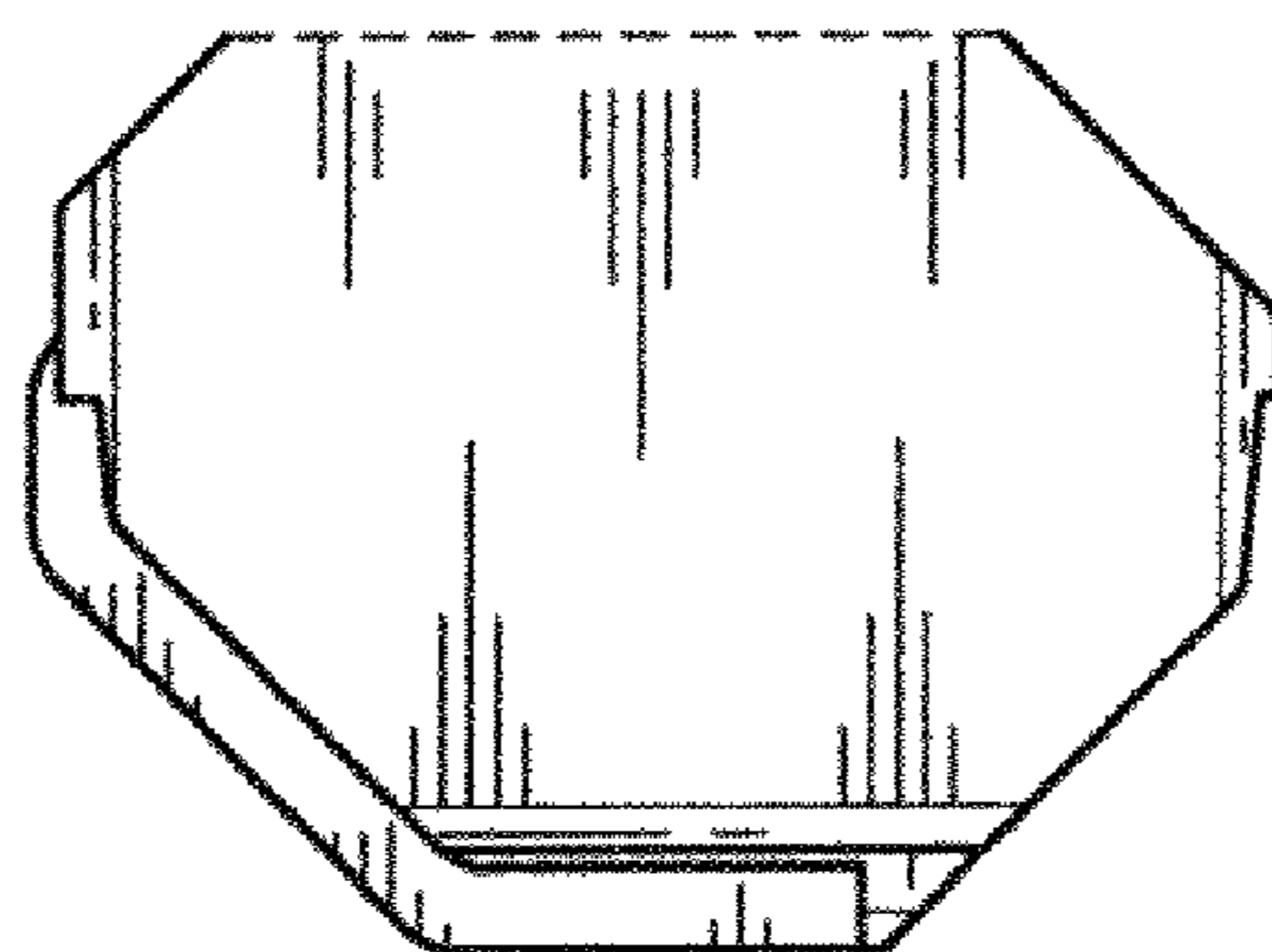

FIG. 5

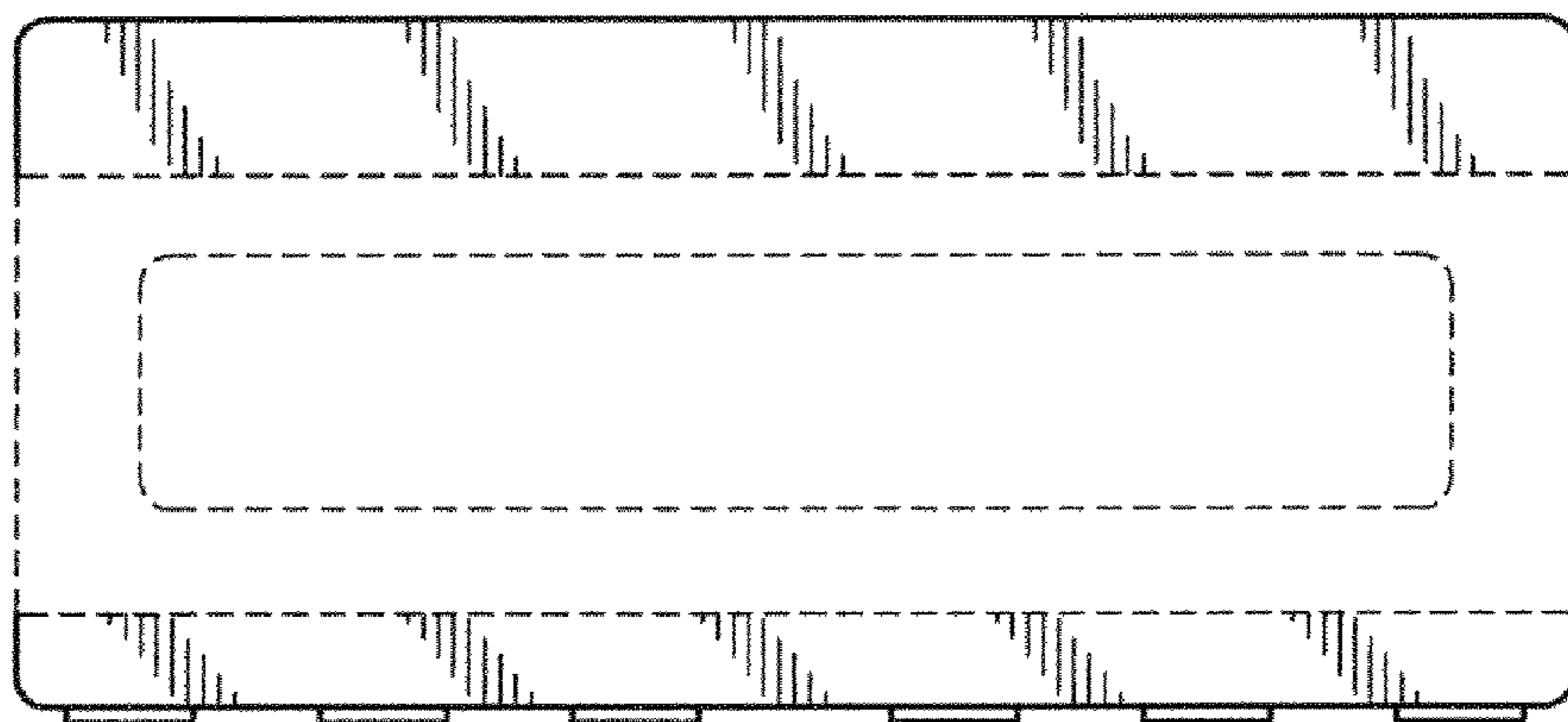

FIG. 6

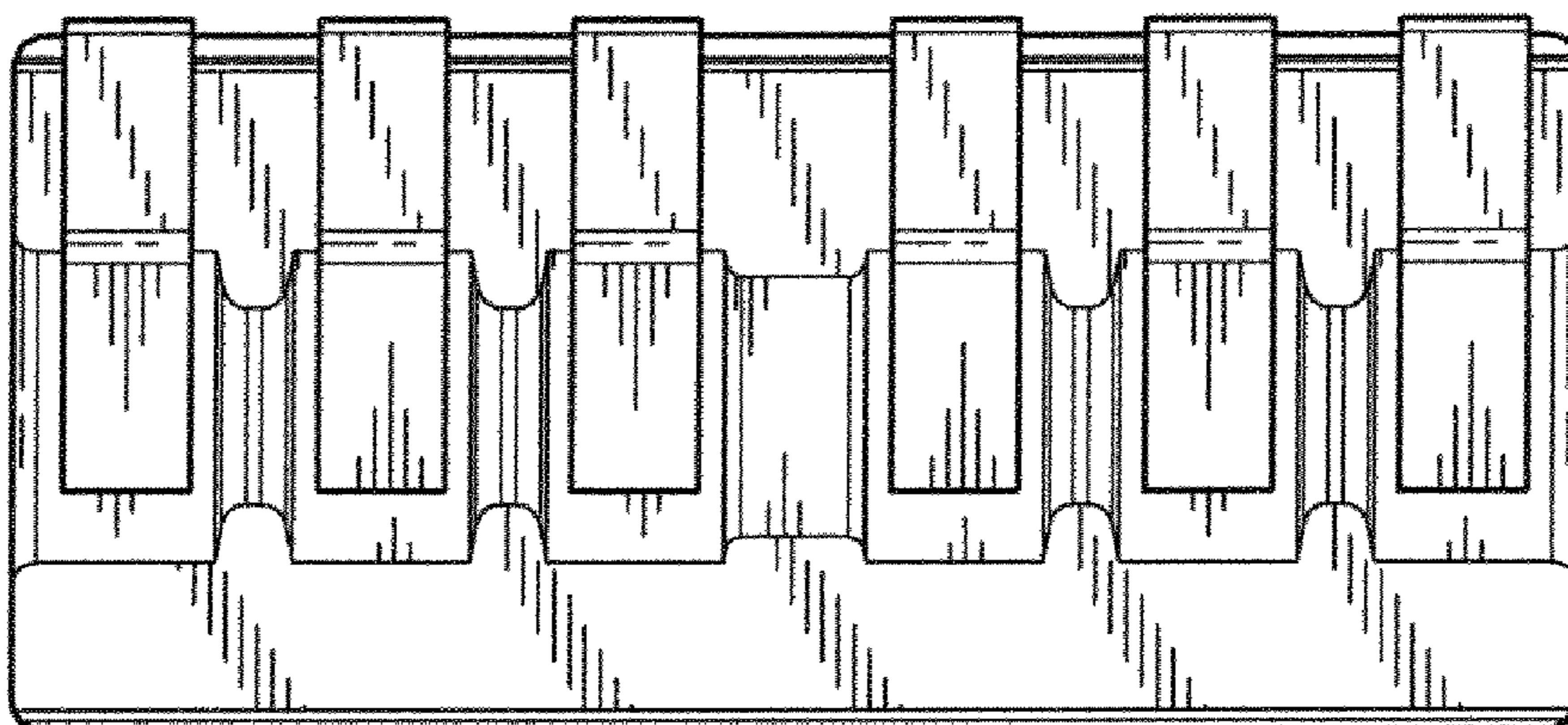

FIG. 7

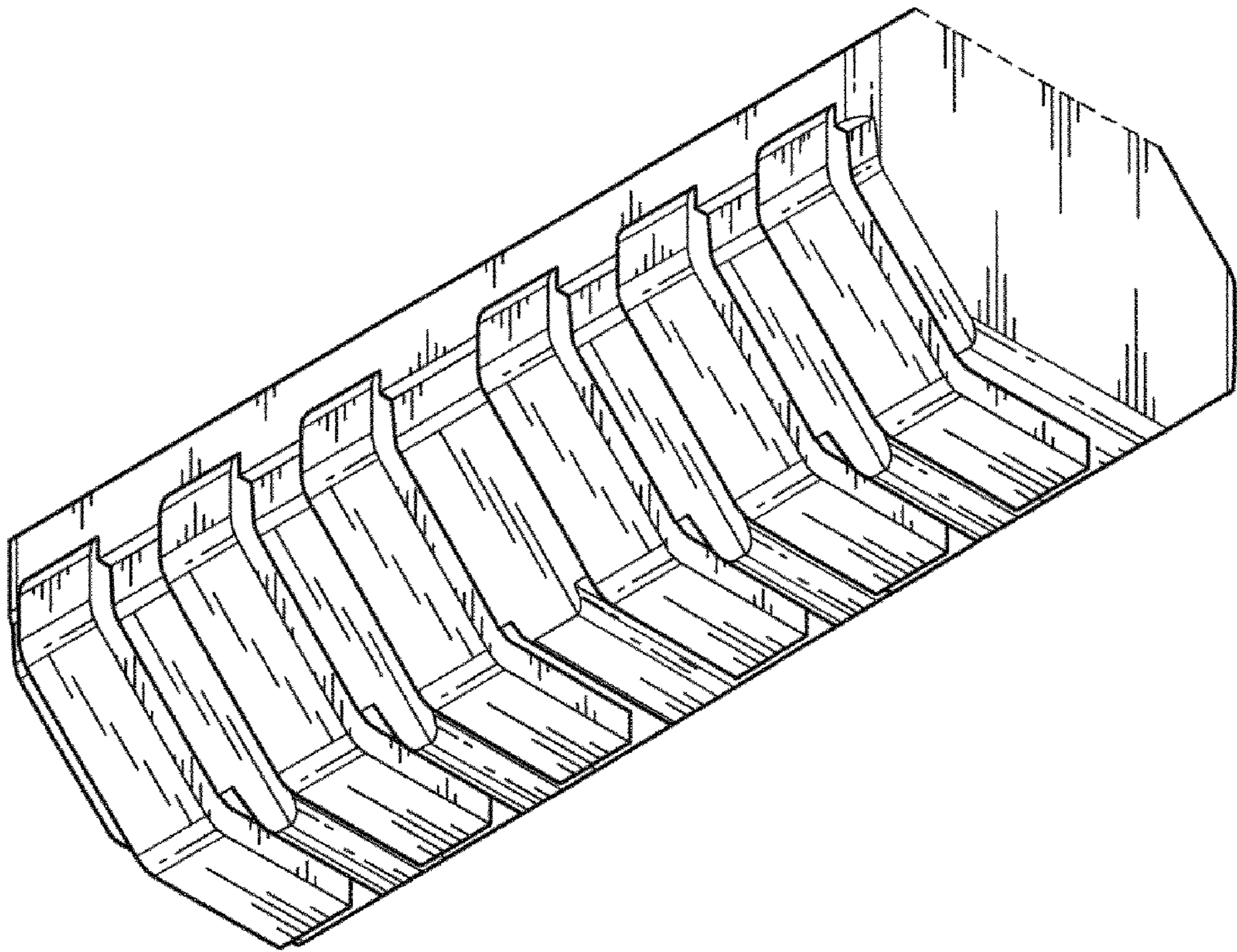

FIG. 8