



US00D656887S

(12) **United States Design Patent**
Bogoslofski et al.

(10) **Patent No.:** **US D656,887 S**

(45) **Date of Patent:** **** Apr. 3, 2012**

(54) **PADDLE BOARD CARRIER**

(75) Inventors: **Kevin Bogoslofski**, Southington, CT (US); **John Laverack**, Southbury, CT (US); **Greg Weaver**, Waterbury, CT (US)

(73) Assignee: **Thule Sweden AB**, Hillerstorp (SE)

(**) Term: **14 Years**

(21) Appl. No.: **29/397,340**

(22) Filed: **Jul. 14, 2011**

(51) **LOC (9) Cl.** **12-16**

(52) **U.S. Cl.** **D12/406**

(58) **Field of Classification Search** D12/401-402, D12/412-414, 414.1, 406; 280/814; 296/140; 224/309, 327, 328, 321, 402, 488, 493, 315
See application file for complete search history.

(56) **References Cited**

U.S. PATENT DOCUMENTS

4,728,019	A *	3/1988	Olliges	224/329
D302,000	S *	7/1989	Arvidsson	D12/412
4,930,671	A *	6/1990	Tittel	224/319
5,119,980	A *	6/1992	Grim et al.	224/315
D332,243	S *	1/1993	Collins	D12/413
D348,034	S *	6/1994	Mann	D12/412
5,456,397	A *	10/1995	Pedrini	224/324
D415,096	S *	10/1999	Englander et al.	D12/406
7,108,163	B1 *	9/2006	Pedrini	224/319

D628,949	S *	12/2010	Farber	D12/412
D633,030	S *	2/2011	Robertson	D12/412
D642,112	S *	7/2011	Farber	D12/414
D642,113	S *	7/2011	Farber	D12/414

* cited by examiner

Primary Examiner — Caron D Veynar

Assistant Examiner — Katrina A Betton

(74) *Attorney, Agent, or Firm* — Novak Druce + Quigg, LLP

(57) **CLAIM**

I claim the ornamental design for a paddle board carrier, as shown and described.

DESCRIPTION

FIG. 1 is a perspective view of a paddle board carrier removably attached to an automotive vehicle;
FIG. 2 is a perspective view of a paddle board carrier;
FIG. 3 is a right side elevational view thereof;
FIG. 4 is left side elevational view thereof;
FIG. 5 is a bottom plan view thereof;
FIG. 6 is a top plan view thereof;
FIG. 7 is a front elevational view thereof; and,
FIG. 8 is a rear elevational view thereof.
The large dashed lines in FIG. 1 are directed to environment and are for illustrative purposes only. The broken lines in FIGS. 1 through 8 illustrate unclaimed portions of the design. The dashed lines and broken lines form no part of the claimed design.

1 Claim, 6 Drawing Sheets

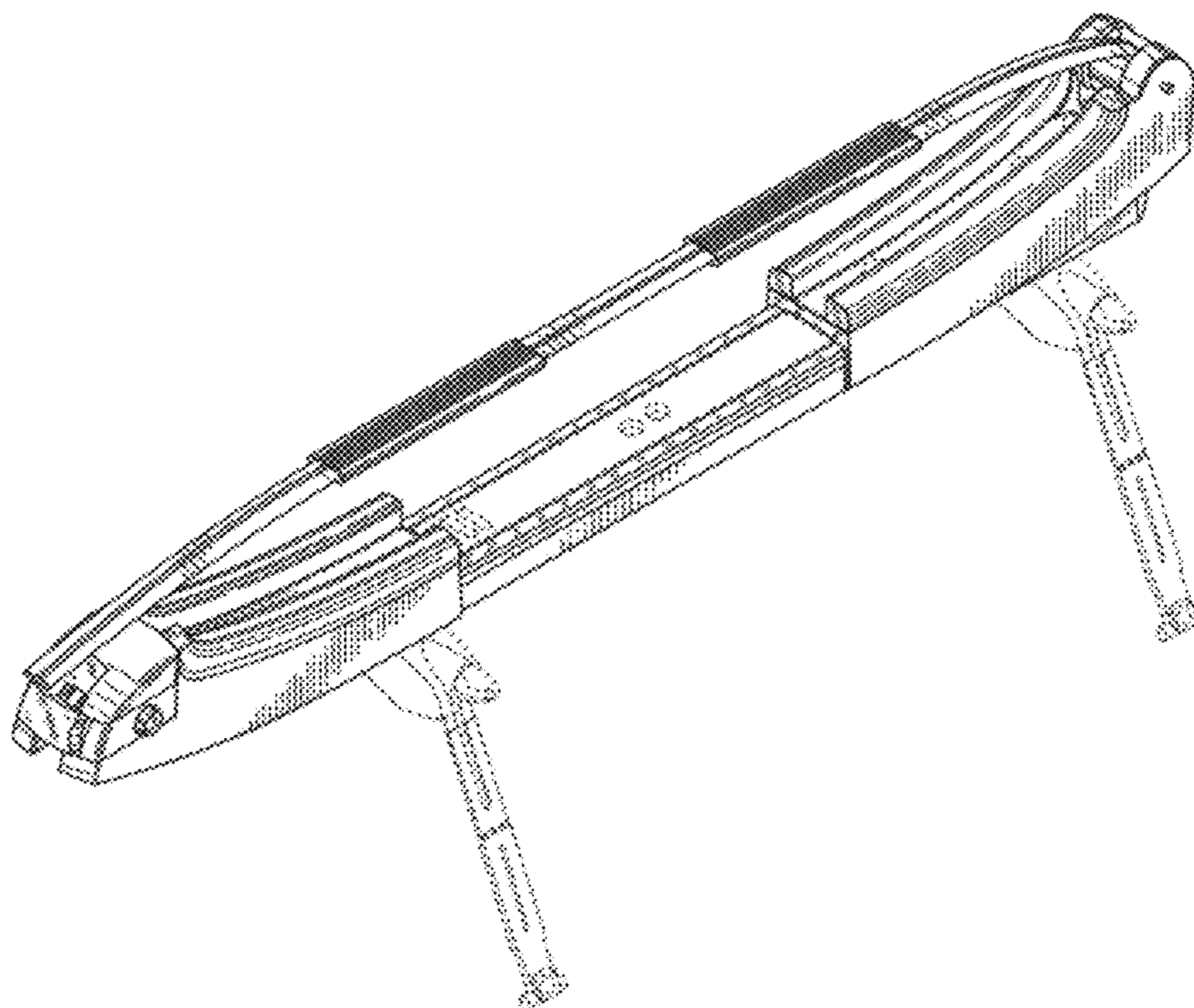

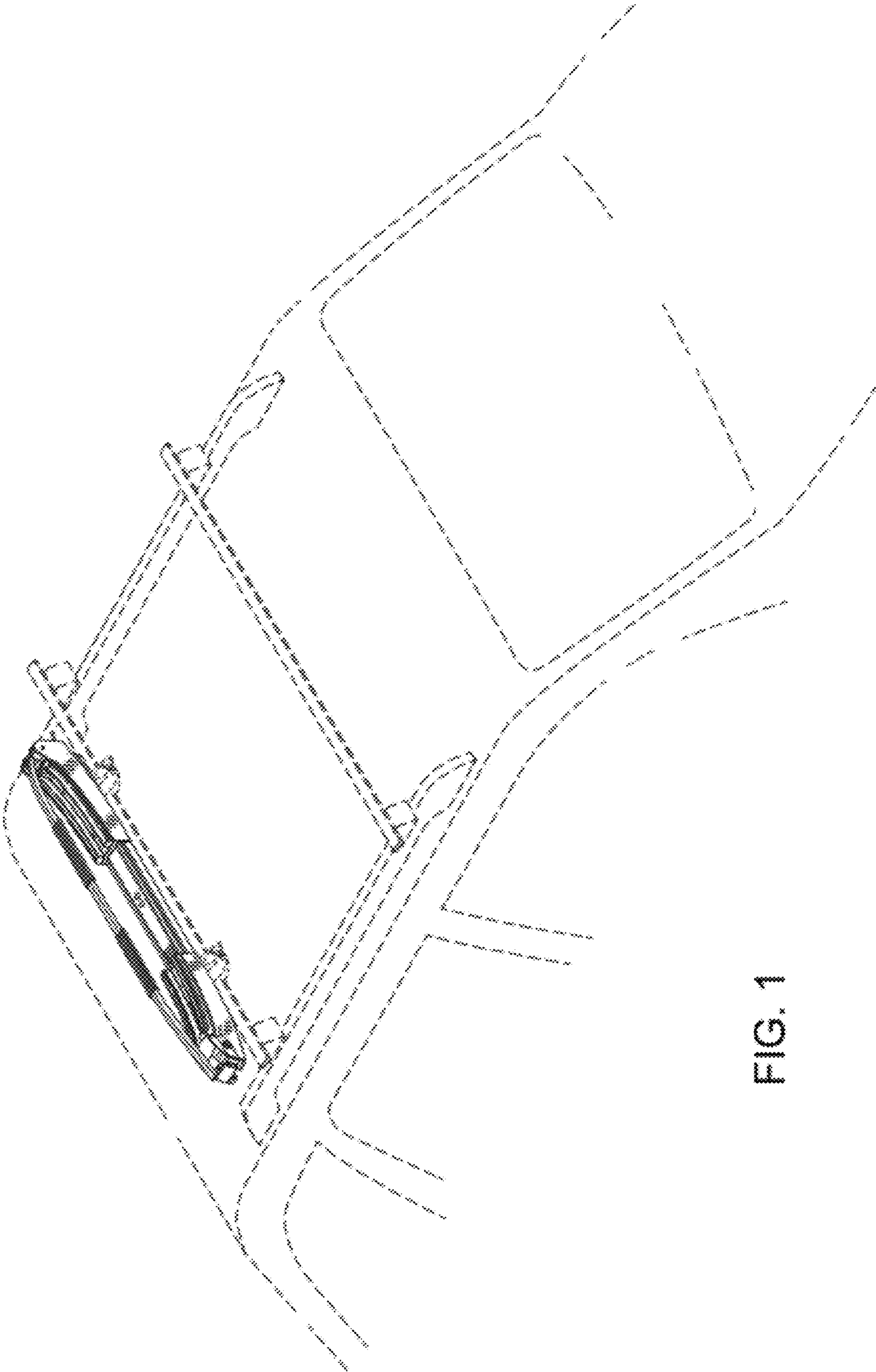

FIG. 1

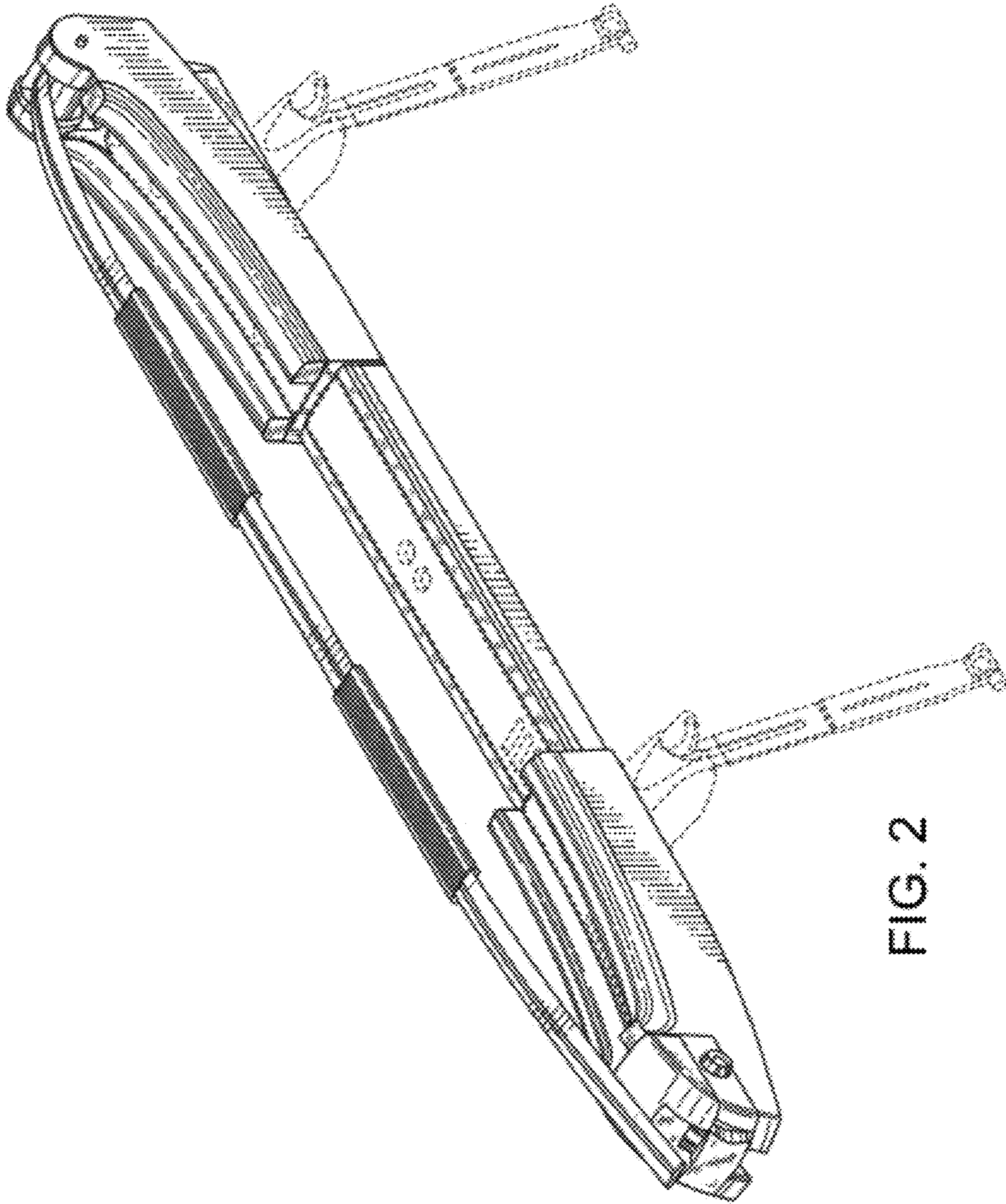

FIG. 2

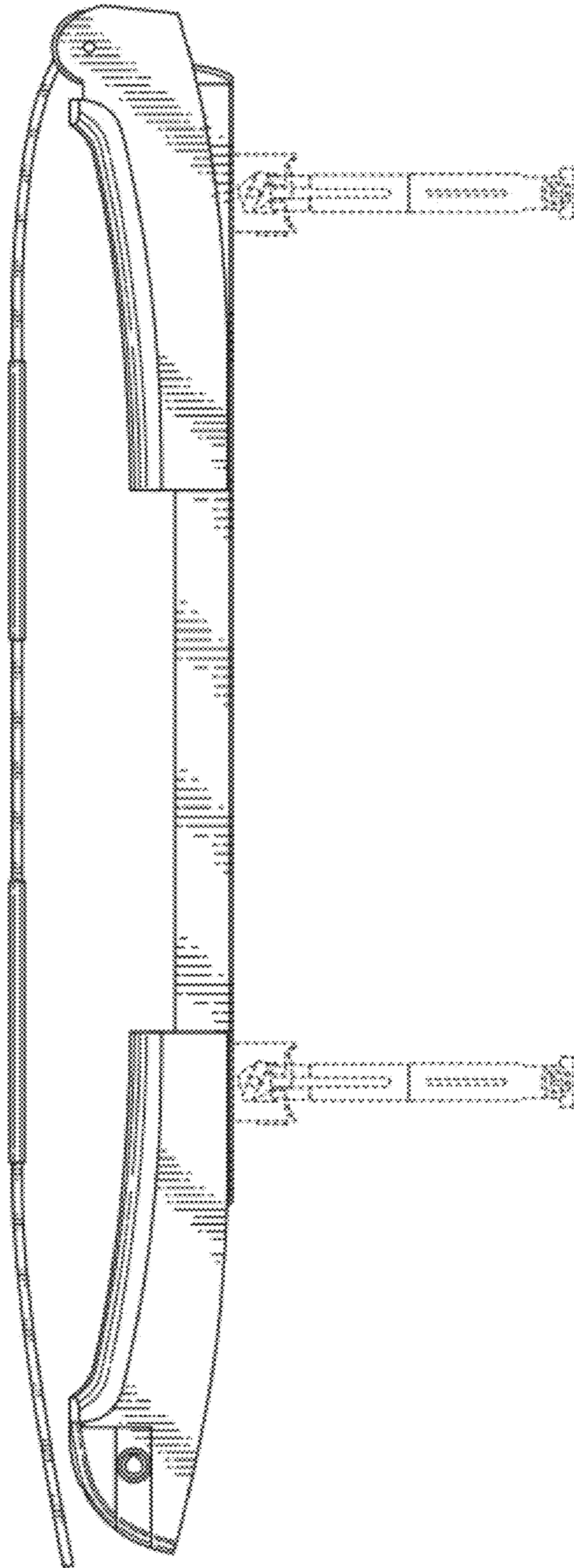

FIG. 3

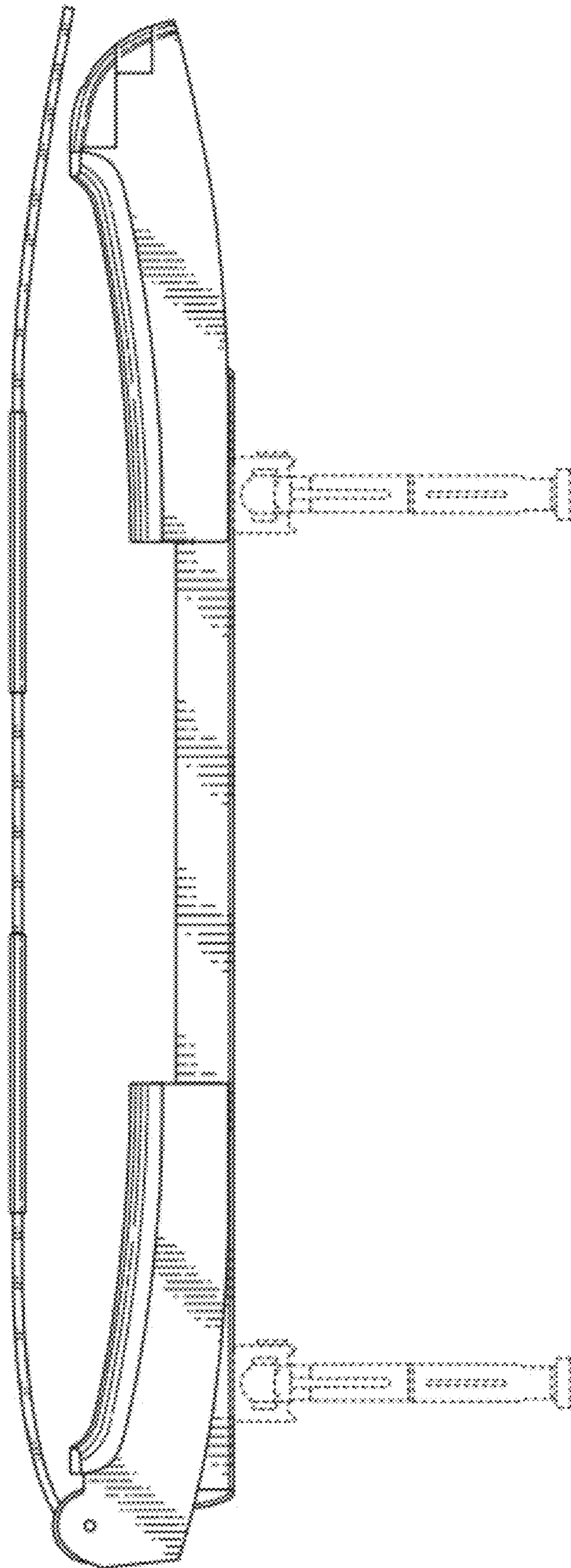

FIG. 4

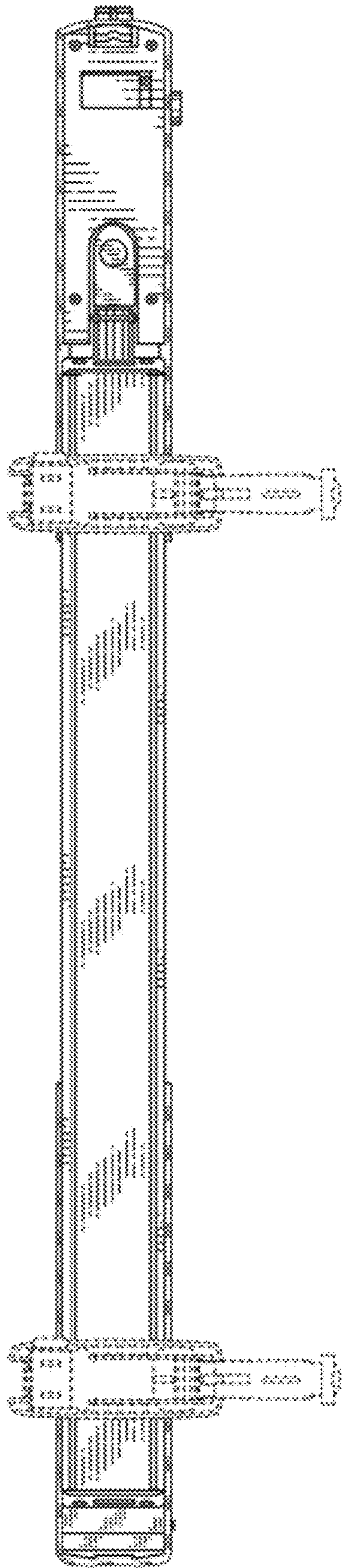

FIG. 5

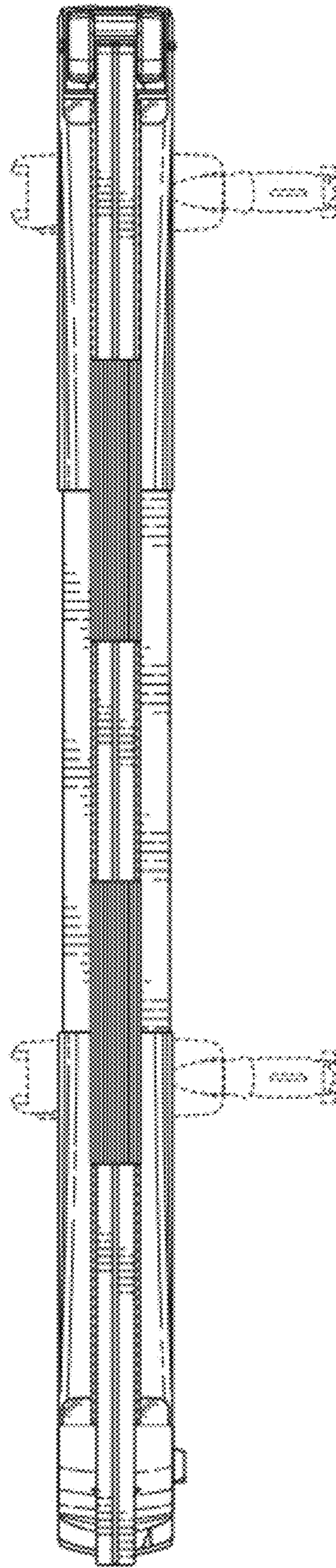

FIG. 6

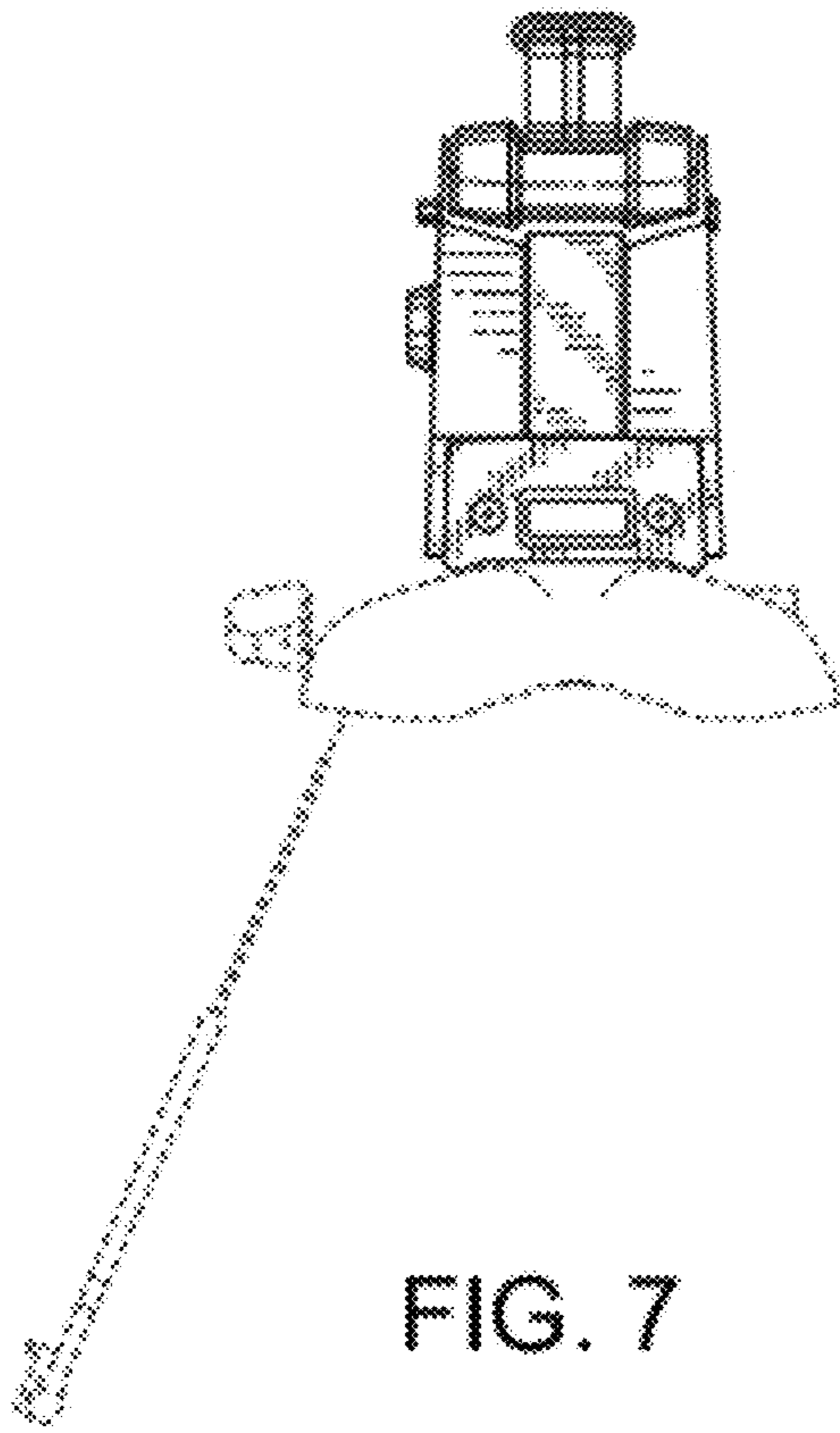

FIG. 7

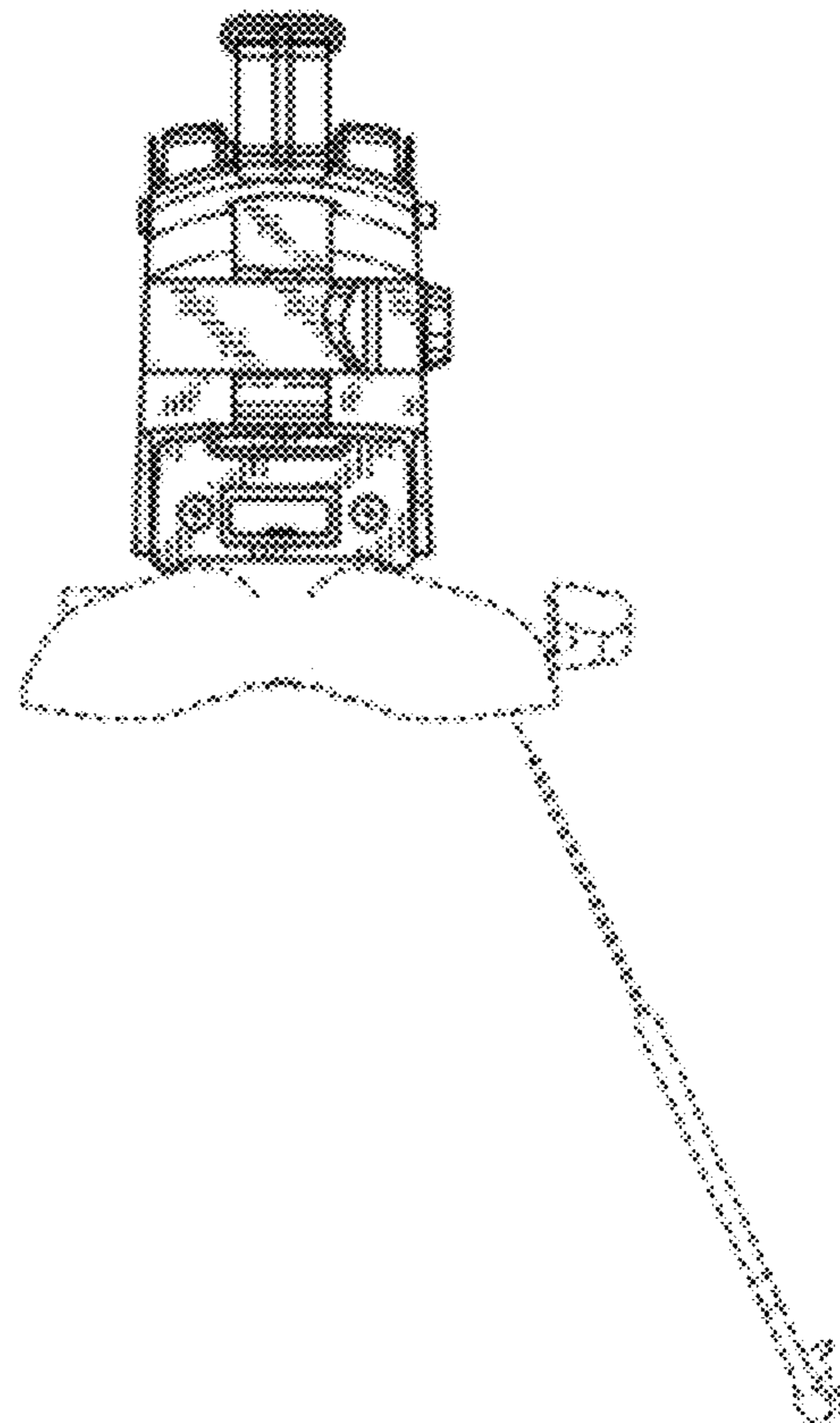

FIG. 8