



US00D656686S

(12) **United States Design Patent**
Decker et al.

(10) **Patent No.:** **US D656,686 S**
(45) **Date of Patent:** **** Mar. 27, 2012**

(54) **AUTO-ARRESTING SAFETY DEVICE**

(75) Inventors: **William M. Decker**, Salt Lake City, UT (US); **Phillip A. Rawlings**, Salt Lake City, UT (US); **Russell L. Margetts**, Murray, UT (US); **John W. Pos**, Holladay, UT (US); **Mathew L. Luntz**, Salt Lake City, UT (US)

(73) Assignee: **LynRus Aluminum Products, LLC**, Salt Lake City, UT (US)

(**) Term: **14 Years**

(21) Appl. No.: **29/357,818**

(22) Filed: **Mar. 17, 2010**

(51) **LOC (9) Cl.** **29-02**

(52) **U.S. Cl.** **D29/124**

(58) **Field of Classification Search** D29/124;
D8/349, 333, 330, 358, 360, 383, 499; 192/223.1;
242/353.5, 383, 383.4; 29/434; 182/239,
182/237, 236, 231, 232; 188/82.77
See application file for complete search history.

(56) **References Cited**

U.S. PATENT DOCUMENTS

2,990,131	A *	6/1961	Carlsson	242/381.5
3,522,944	A	8/1970	Schroeder	
3,704,017	A	11/1972	Young	
4,171,795	A	10/1979	Bianchi	
4,480,716	A *	11/1984	Soubry et al.	182/233
4,511,123	A	4/1985	Ostobrod	
4,538,703	A *	9/1985	Ellis et al.	182/5
4,589,523	A	5/1986	Olson et al.	
4,846,313	A	7/1989	Sharp	
4,877,110	A	10/1989	Wolner	
4,913,371	A	4/1990	Margetts	
5,447,280	A *	9/1995	Feathers	242/381.5
D377,447	S *	1/1997	Blye	D8/358
5,722,612	A	3/1998	Feathers	
5,771,993	A	6/1998	Anderson et al.	
5,829,548	A *	11/1998	Ostobrod	182/18
5,899,298	A	5/1999	Crouse, Jr.	
D410,375	S *	6/1999	Yacobi et al.	D8/358
D415,998	S *	11/1999	Brown et al.	D13/154

6,279,682	B1	8/2001	Feathers	
D449,513	S *	10/2001	Stekelenburg	D8/358
D468,189	S *	1/2003	Kovacik et al.	D8/358
D490,575	S *	5/2004	Henson	D29/124
6,763,913	B1 *	7/2004	Adams	182/231
D523,588	S *	6/2006	Henson	D29/101.4
7,210,645	B2 *	5/2007	Paterson et al.	242/383.4
7,226,038	B1	6/2007	Wickstrom	
7,237,650	B2 *	7/2007	Casebolt	182/231

(Continued)

Primary Examiner — Mark Goodwin

(74) *Attorney, Agent, or Firm* — Thorpe North & Western LLP

(57) **CLAIM**

The ornamental design for an auto-arresting safety device, as shown and described.

DESCRIPTION

FIG. 1 is a top perspective view of an auto-arresting safety device showing our new design;
 FIG. 2 is a rear view thereof;
 FIG. 3 is a front view thereof;
 FIG. 4 is a first side view thereof;
 FIG. 5 is a second side view thereof;
 FIG. 6 is a top plan view thereof;
 FIG. 7 is a bottom plan view thereof;
 FIG. 8 is a perspective view of the inner surfaces of the rear housing component thereof;
 FIG. 9 is a front view thereof;
 FIG. 10 is a perspective view of the inner surfaces of the front housing component thereof;
 FIG. 11 is a front view thereof; and,
 FIG. 12 is a perspective view of a second embodiment for an auto-arresting safety device showing our new design, the only difference being the configuration of the rear housing, which is devoid of lugs formed in the outer surface of the housing, it being understood that all other surfaces are the same as those of the first embodiment.

The broken line showing in FIGS. 1-11 is included for the purpose of illustrating portions of the auto-arresting safety device and forms no part of the claimed design.

1 Claim, 12 Drawing Sheets

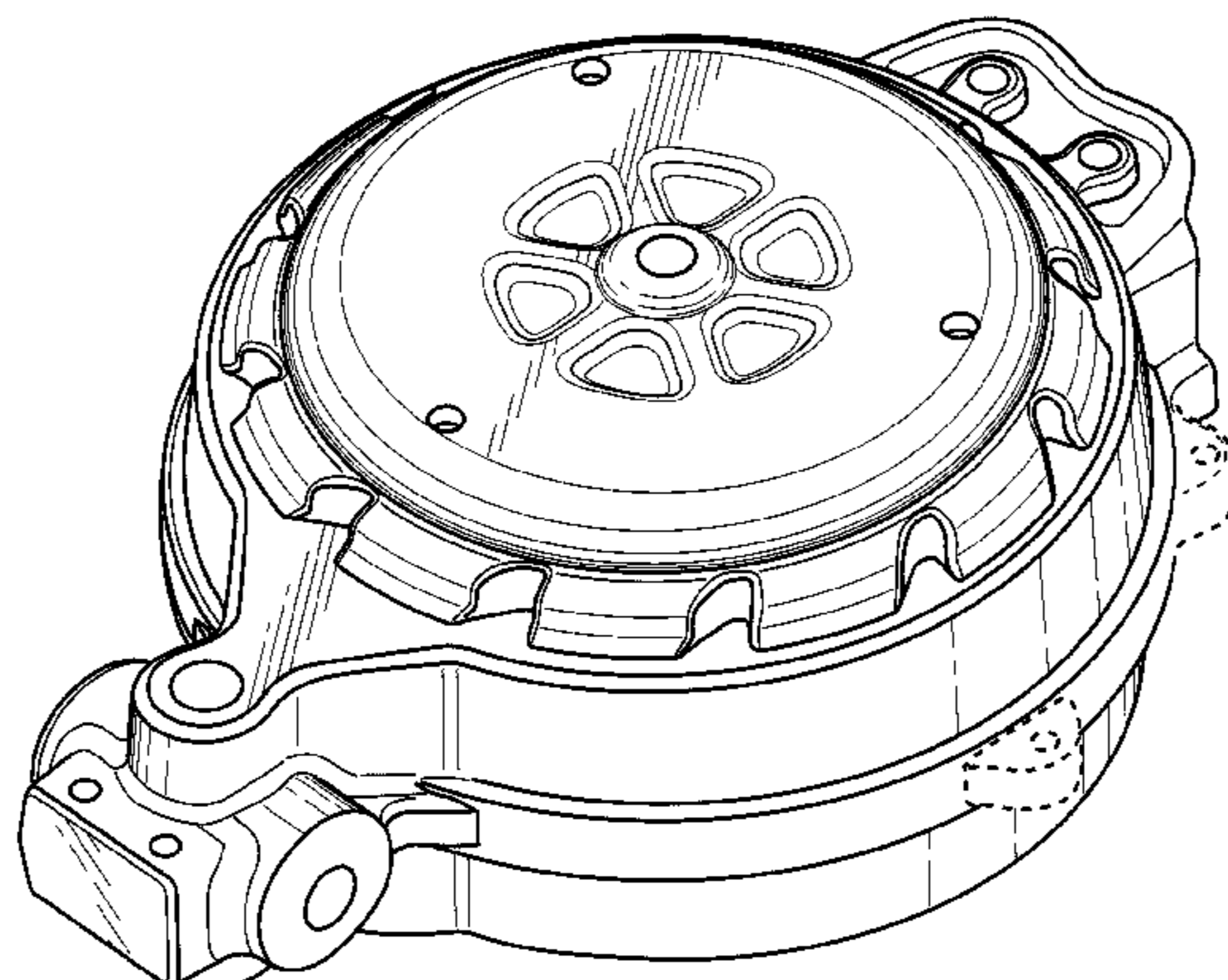

US D656,686 S

Page 2

U.S. PATENT DOCUMENTS							
				D628,043	S *	11/2010	Young et al. D8/333
7,281,620	B2	10/2007	Wolner et al.	7,857,099	B2 *	12/2010	Choate 182/234
D584,937	S *	1/2009	Kovacik et al. D8/358	7,870,934	B2 *	1/2011	Ecker 182/239
D587,410	S *	2/2009	Wolner et al. D29/124	7,946,387	B2 *	5/2011	Betcher et al. 182/231
7,744,063	B2 *	6/2010	Jones 254/392				

* cited by examiner

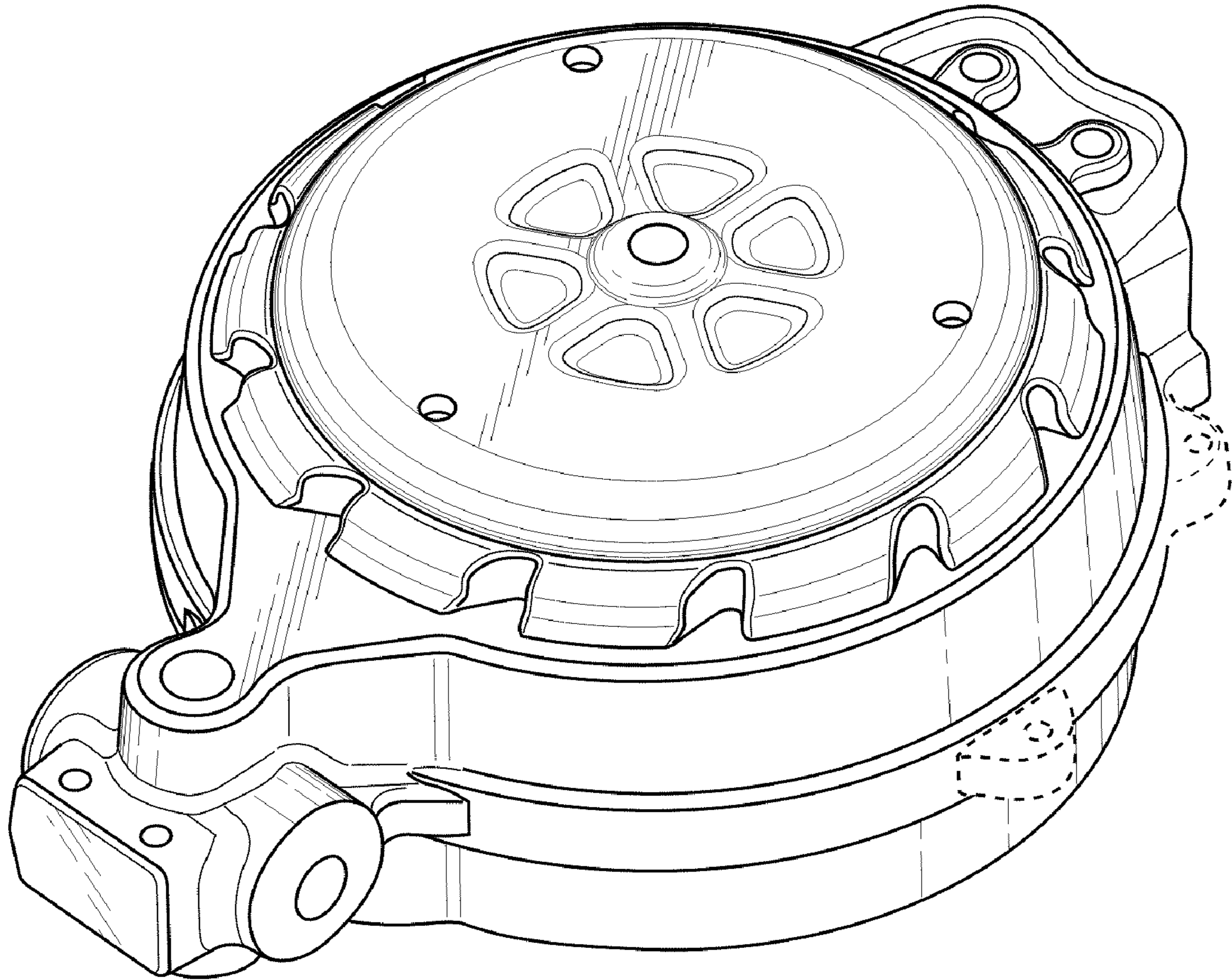

Fig. 1

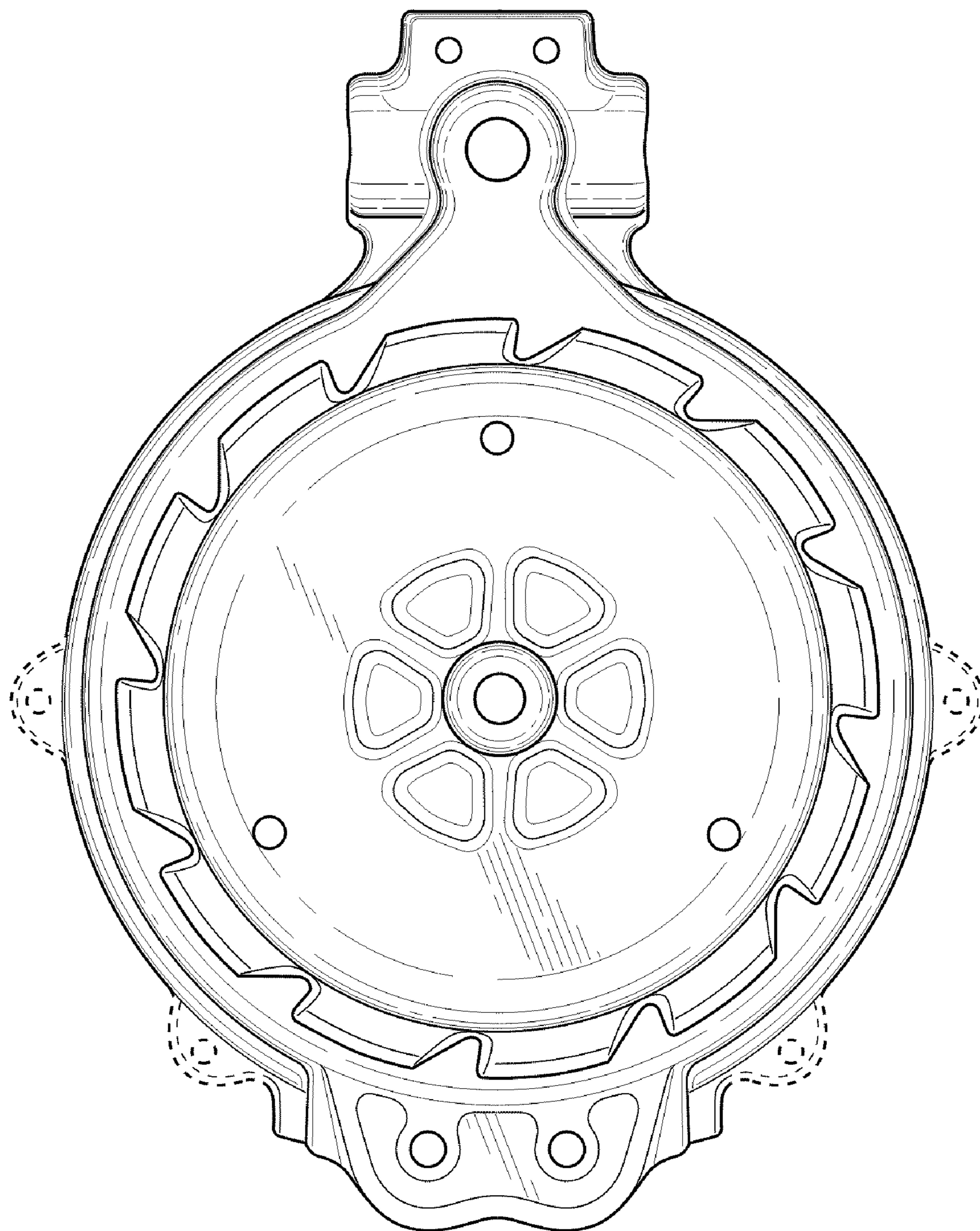

Fig. 2

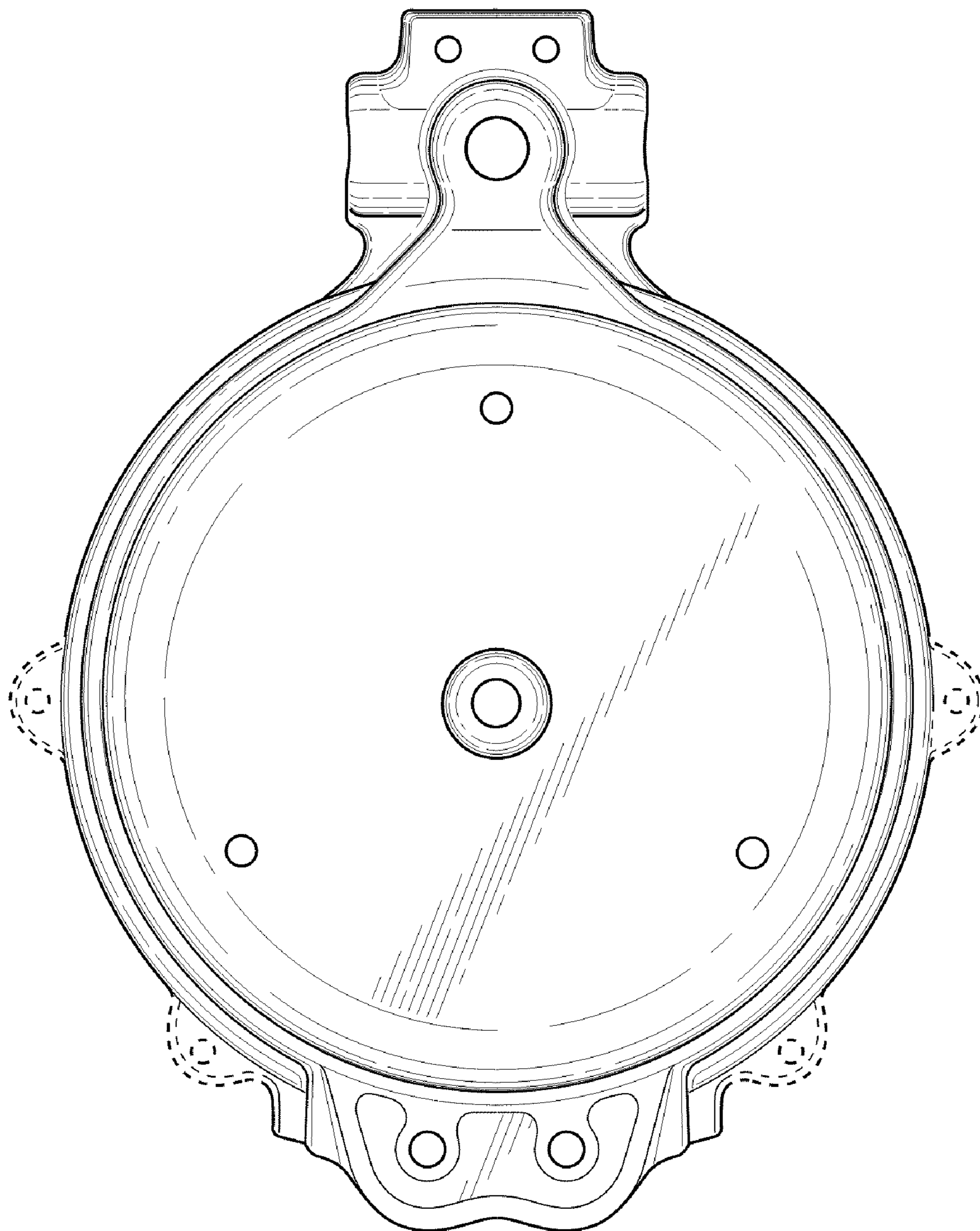

Fig. 3

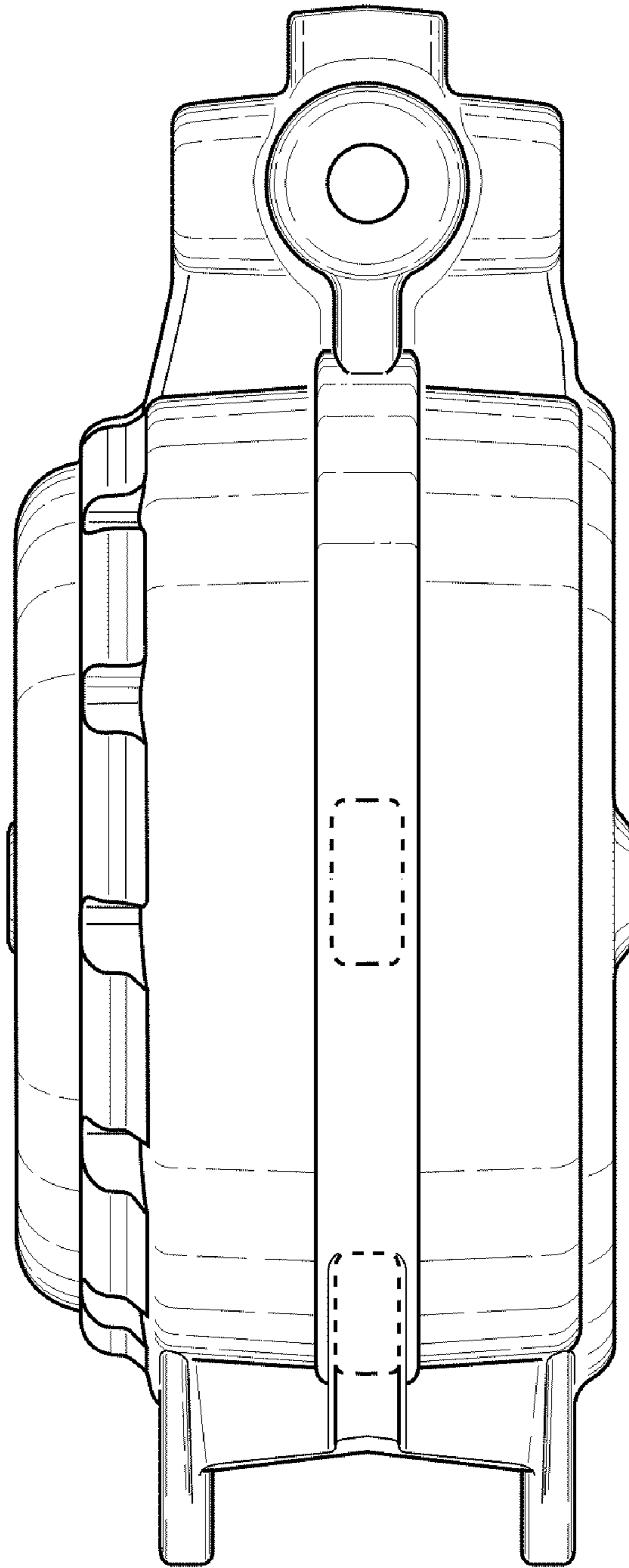

Fig. 4

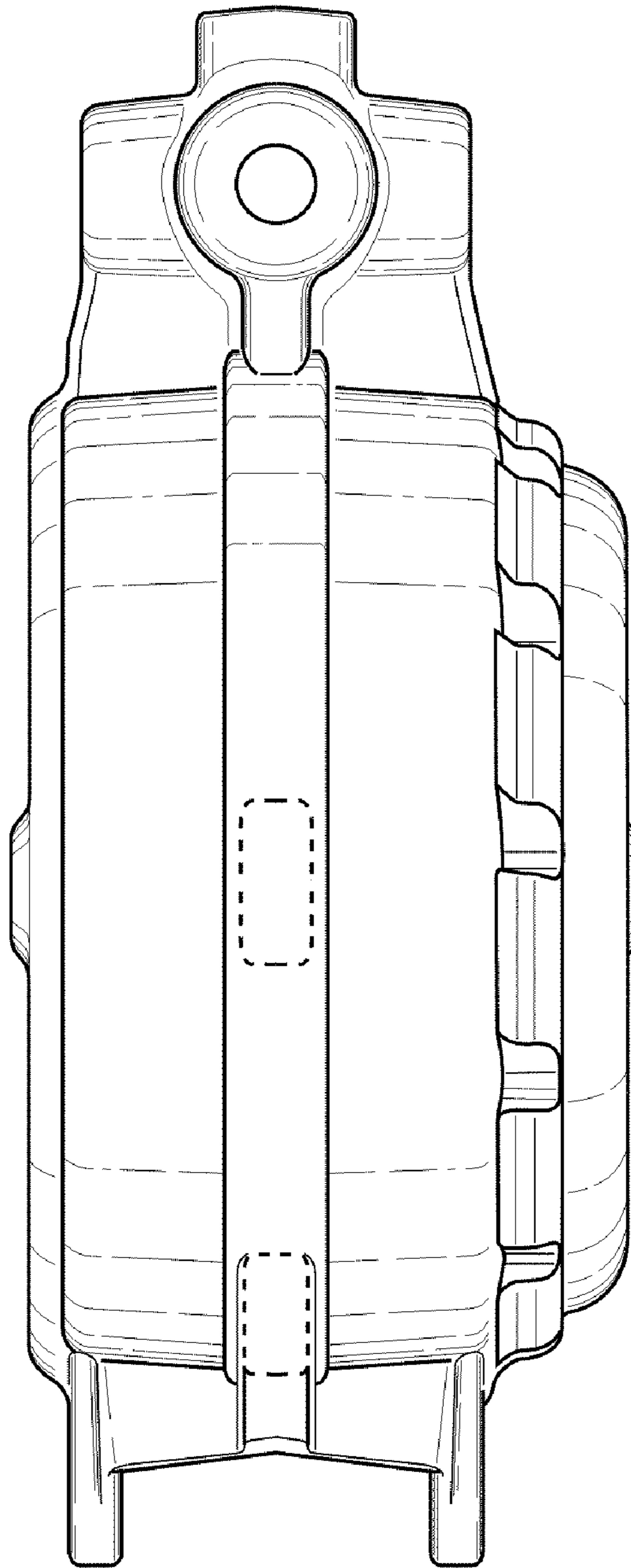

Fig. 5

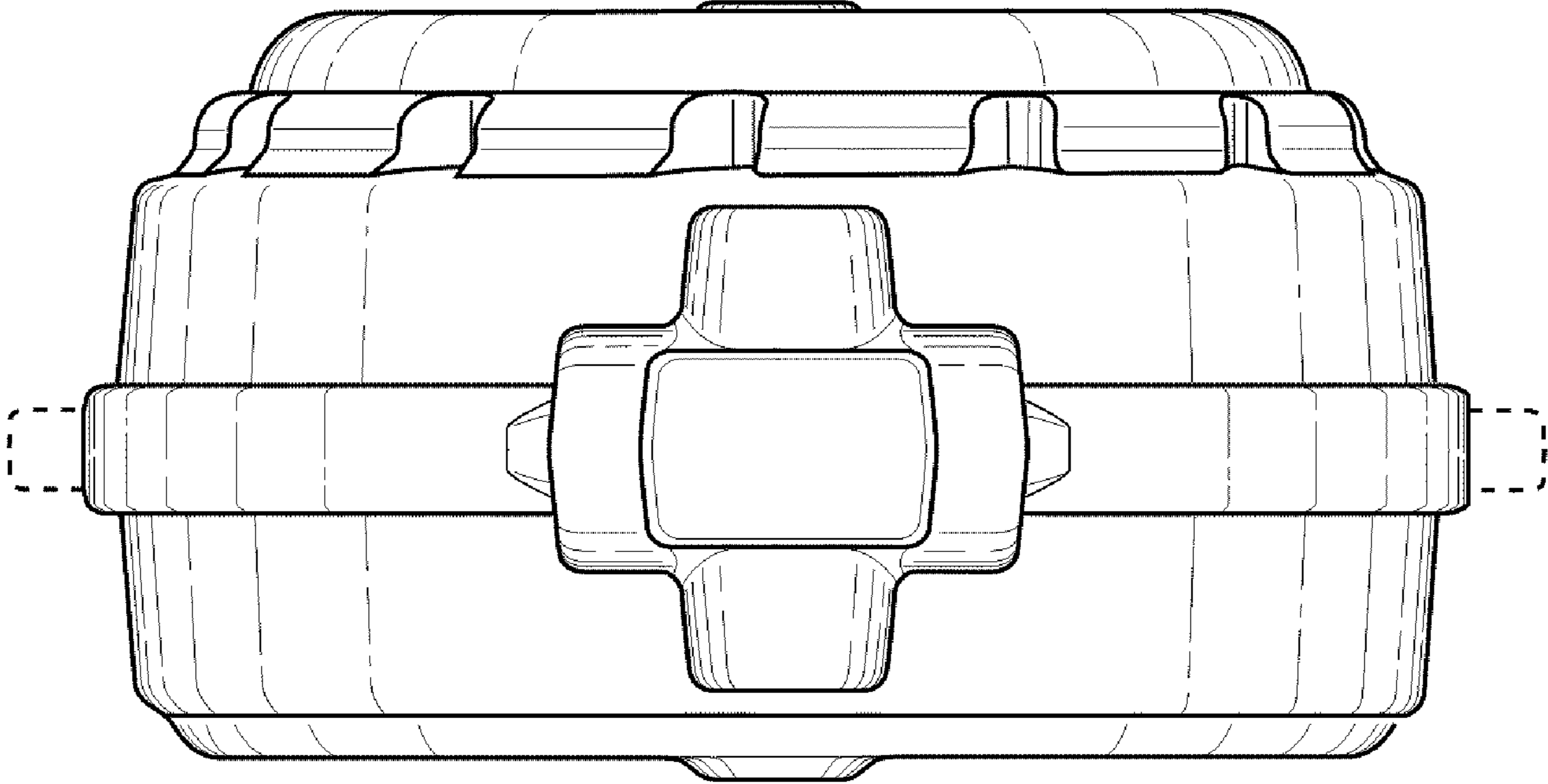

Fig. 6

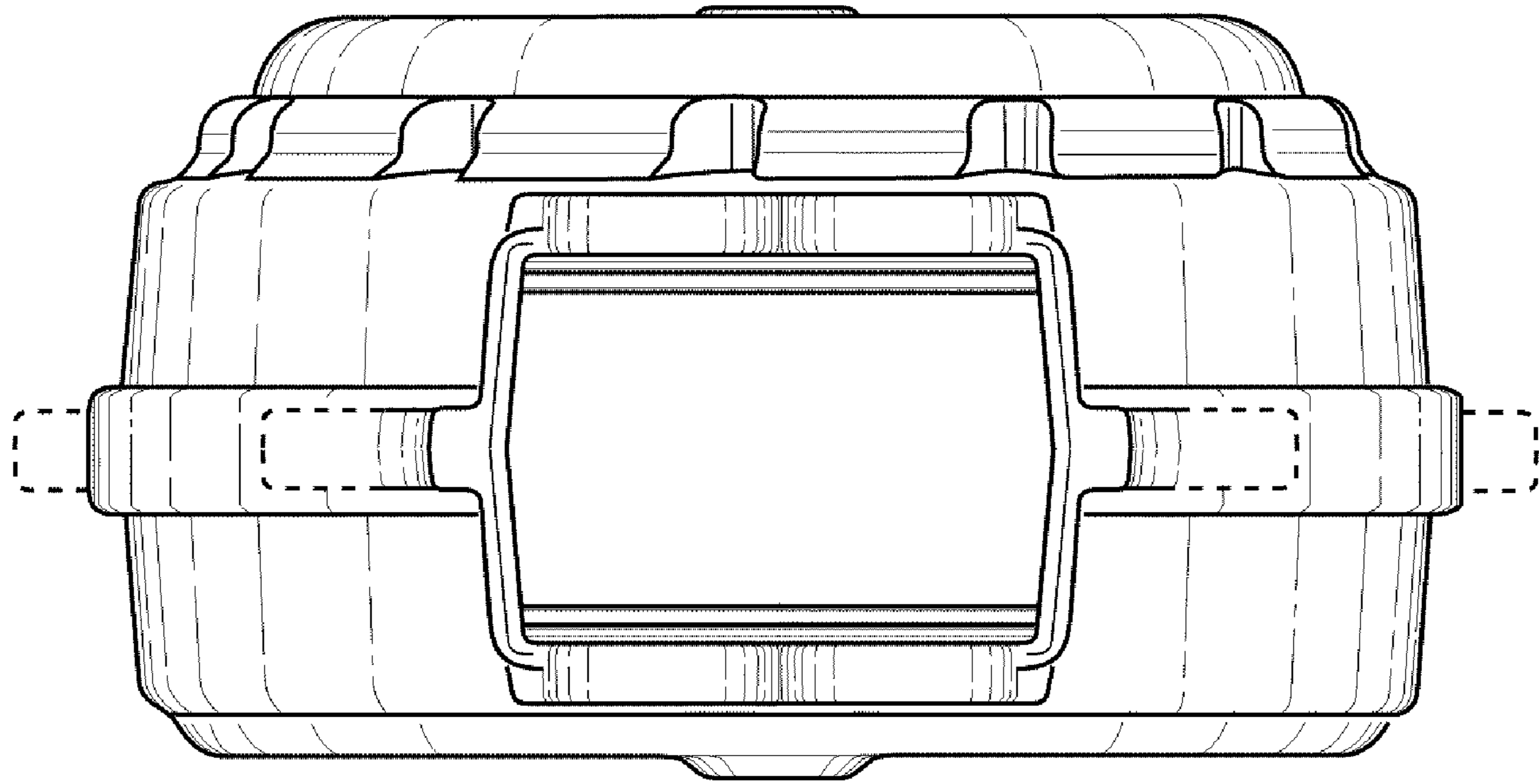

Fig. 7

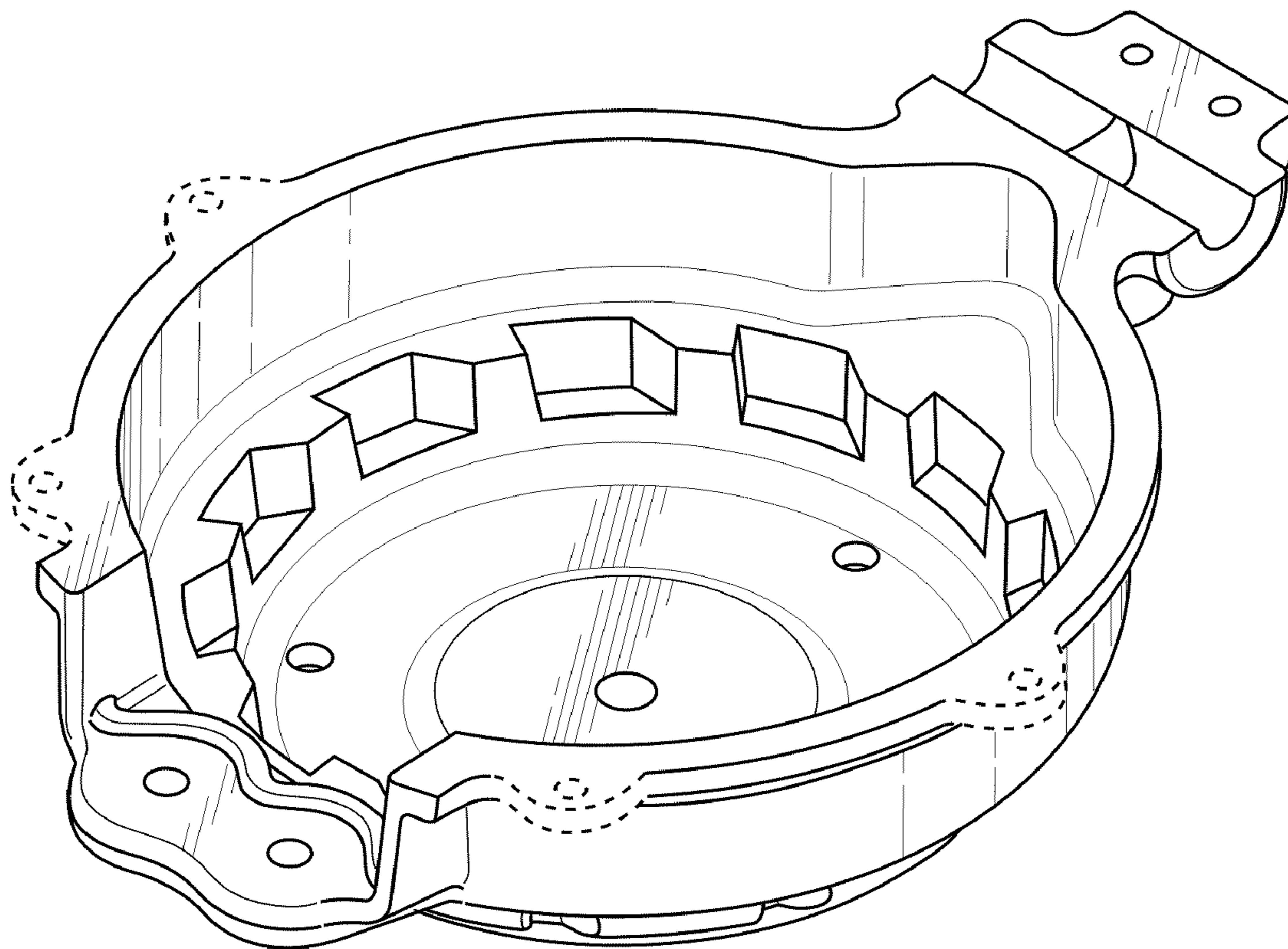

Fig. 8

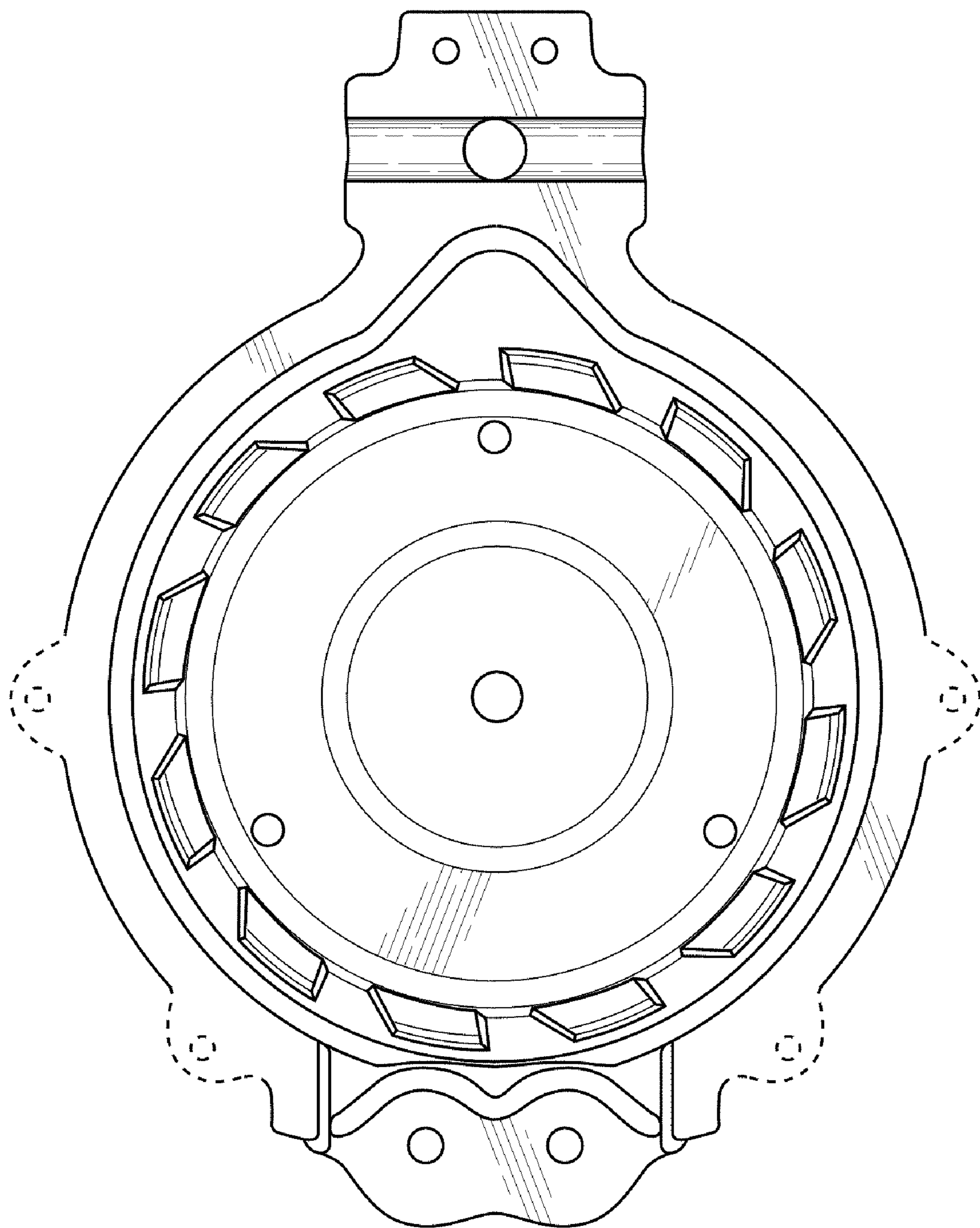

Fig. 9

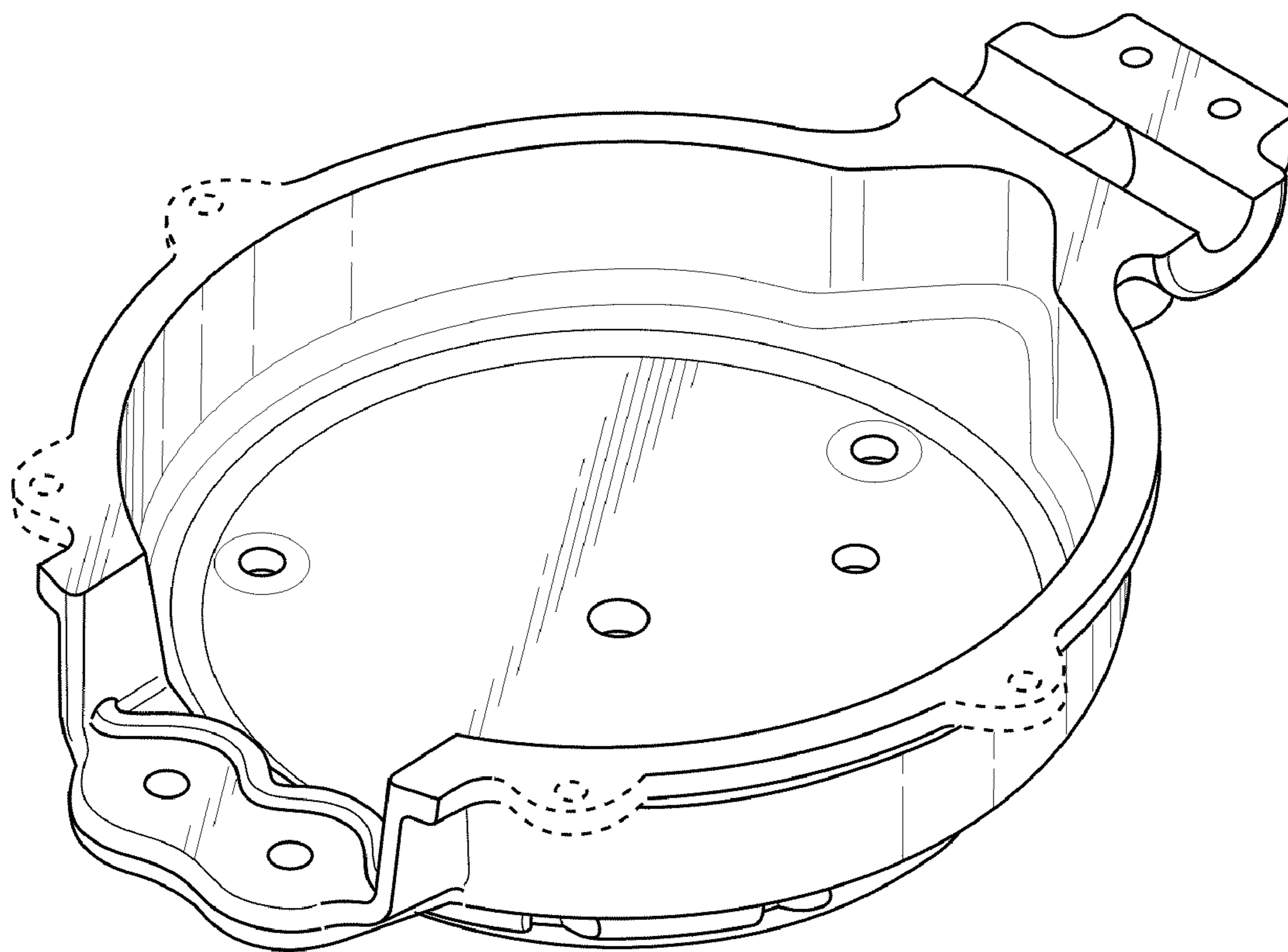

Fig. 10

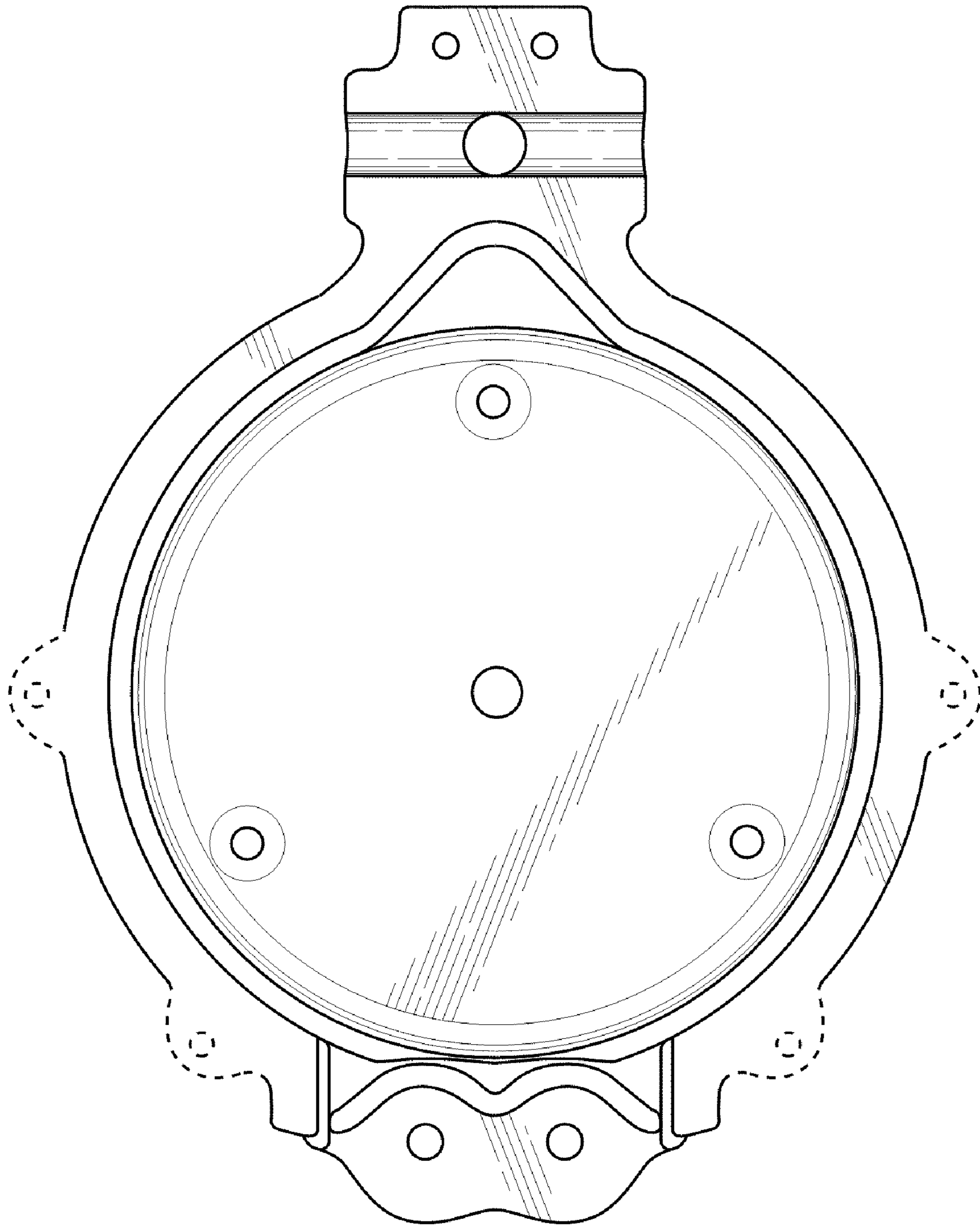

Fig. 11

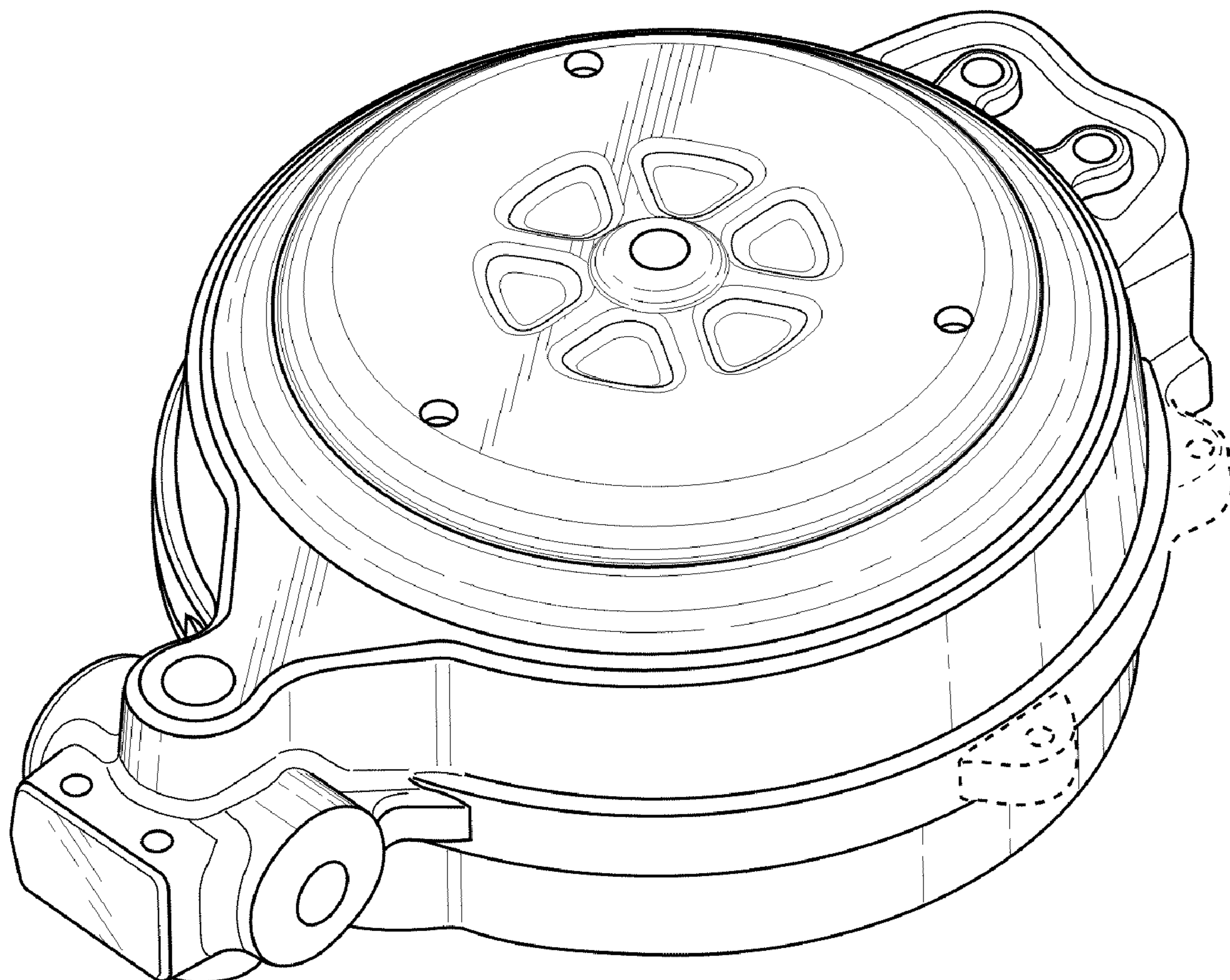

Fig. 12