



US00D656089S

(12) **United States Design Patent**
Miyazaki

(10) **Patent No.:** **US D656,089 S**
(45) **Date of Patent:** **** Mar. 20, 2012**

- (54) **TIRE**
- (75) Inventor: **Tetsuji Miyazaki**, Osaka (JP)
- (73) Assignee: **Toyo Tire & Rubber Co., Ltd.**, Osaka (JP)
- (**) Term: **14 Years**
- (21) Appl. No.: **29/382,854**
- (22) Filed: **Jan. 7, 2011**

Primary Examiner — Stacia Cadmus
(74) *Attorney, Agent, or Firm* — Sterne, Kessler, Goldstein & Fox PLLC

(30) **Foreign Application Priority Data**

- Nov. 25, 2010 (JP) 2010-028172
- (51) **LOC (9) Cl.** **12-15**
- (52) **U.S. Cl.** **D12/605**
- (58) **Field of Classification Search** D12/500-50,
D12/544, 579, 600-605; 152/523-524, DIG. 12,
152/555; D7/588, 396.4-396.5
See application file for complete search history.

(57) **CLAIM**
The ornamental design for a tire, as shown and described.

DESCRIPTION

FIG. 1 is a front view of a tire showing my new design;
 FIG. 2 is a rear view thereof;
 FIG. 3 is a left side view thereof, for which the right side view is a mirror image;
 FIG. 4 is a top plan view thereof, for which the bottom plan view is a mirror image;
 FIG. 5 is a perspective view thereof;
 FIG. 6 is an enlarged view taken along lines 6-6 and 6'-6' in FIG. 1;
 FIG. 7 is an enlarged cross-sectional view taken along line 7-7 in FIG. 4 and lines 7'-7' and 7''-7''' in FIG. 6;
 FIG. 8 is an enlarged cross-sectional view taken along line 7-7 in FIG. 4 and lines 7'-7' and 8-8 in FIG. 6;
 FIG. 9 is an enlarged cross-sectional view taken along line 7-7 in FIG. 4 and lines 7'-7' and 9-9 in FIG. 6;
 FIG. 10 is an enlarged cross-sectional view taken along line 7-7 in FIG. 4 and lines 7'-7' and 10-10 in FIG. 6; and
 FIG. 11 is an enlarged view taken along lines 11-11 and 11'-11' in FIG. 1; and,
 FIG. 12 is an enlarged cross-sectional view taken along lines 12-12 and 12'-12' in FIG. 11.

In the drawings, the broken lines defining portions of the tire tread, sidewall, and inner bead depict environmental subject matter that forms no part of the claimed design.

(56) **References Cited**

U.S. PATENT DOCUMENTS

D123,895 S *	12/1940	Rideout	D12/605
D415,724 S *	10/1999	Johnson	D12/605
D488,122 S *	4/2004	Palo et al.	D12/605
D542,219 S *	5/2007	Shondel et al.	D12/605
D549,640 S *	8/2007	Karen	D12/605
D549,641 S *	8/2007	Karen	D12/605
D552,534 S *	10/2007	Brummer	D12/605
D553,556 S *	10/2007	Karen	D12/503
D571,287 S *	6/2008	Dixon	D12/605
D597,480 S *	8/2009	Umstot et al.	D12/605
D606,013 S *	12/2009	Reese et al.	D12/605
D638,783 S *	5/2011	Endou et al.	D12/605

FOREIGN PATENT DOCUMENTS

JP	1319191	1/2008
JP	1334761	6/2008
JP	1366847	8/2009

* cited by examiner

1 Claim, 8 Drawing Sheets

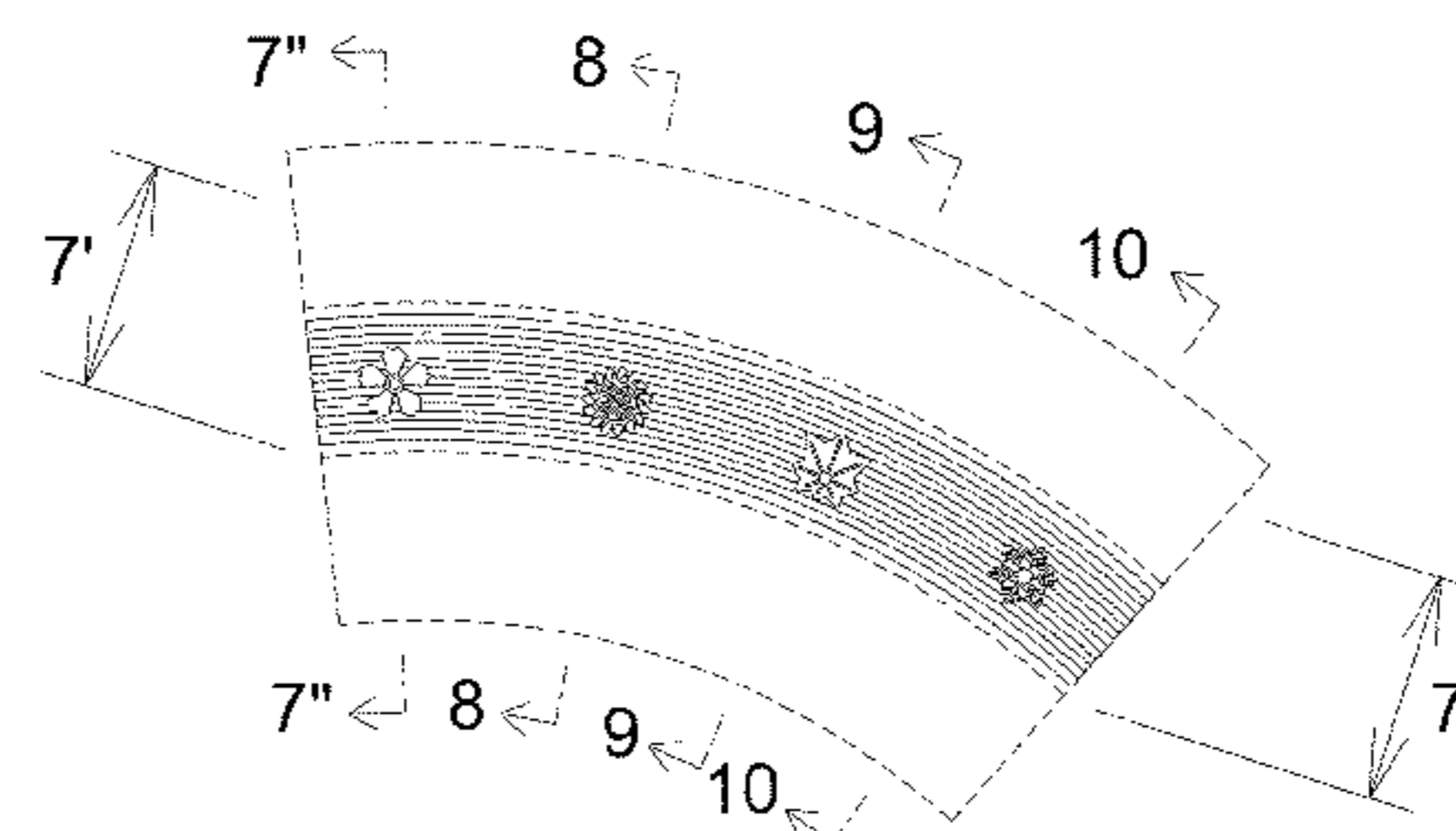
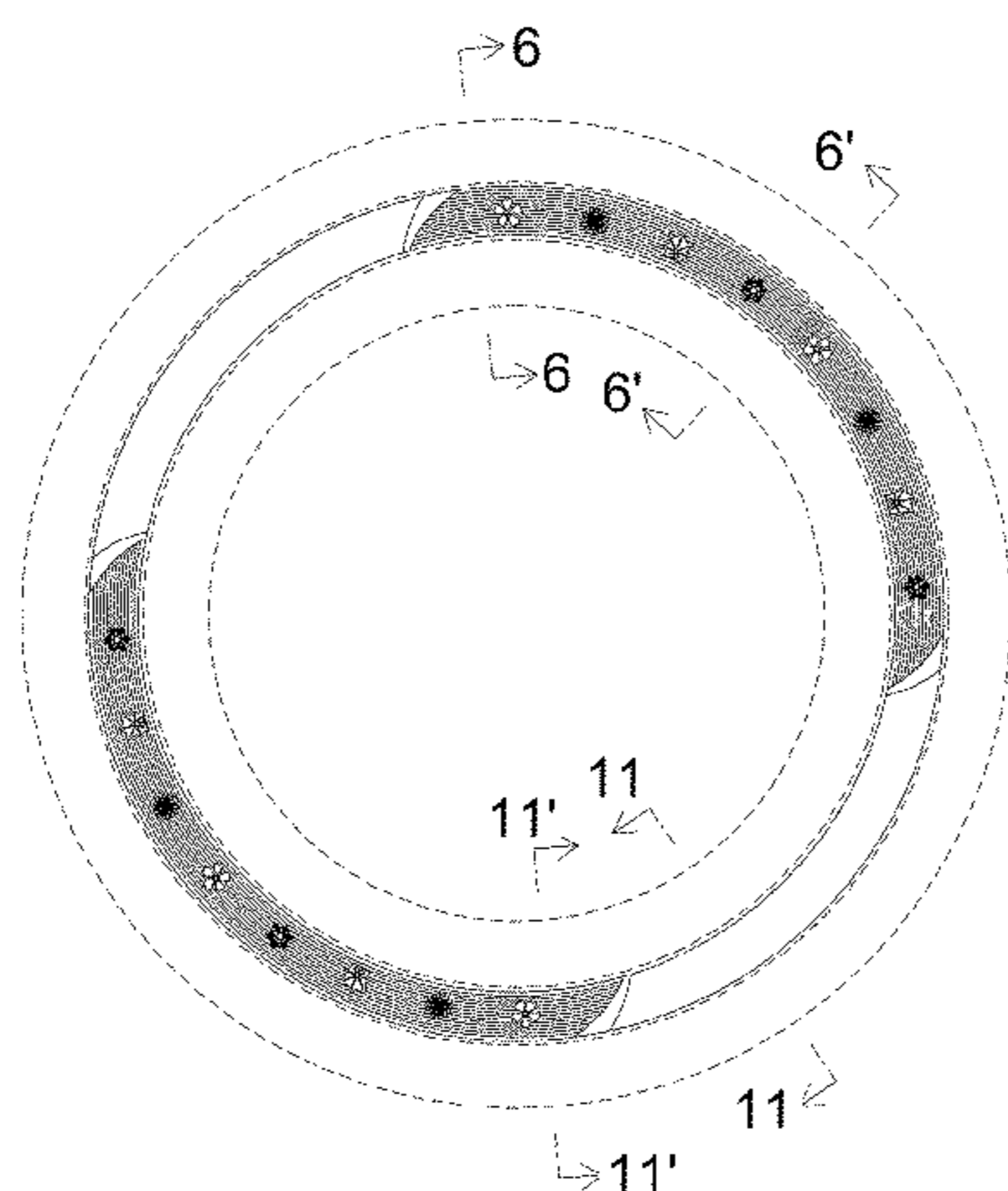

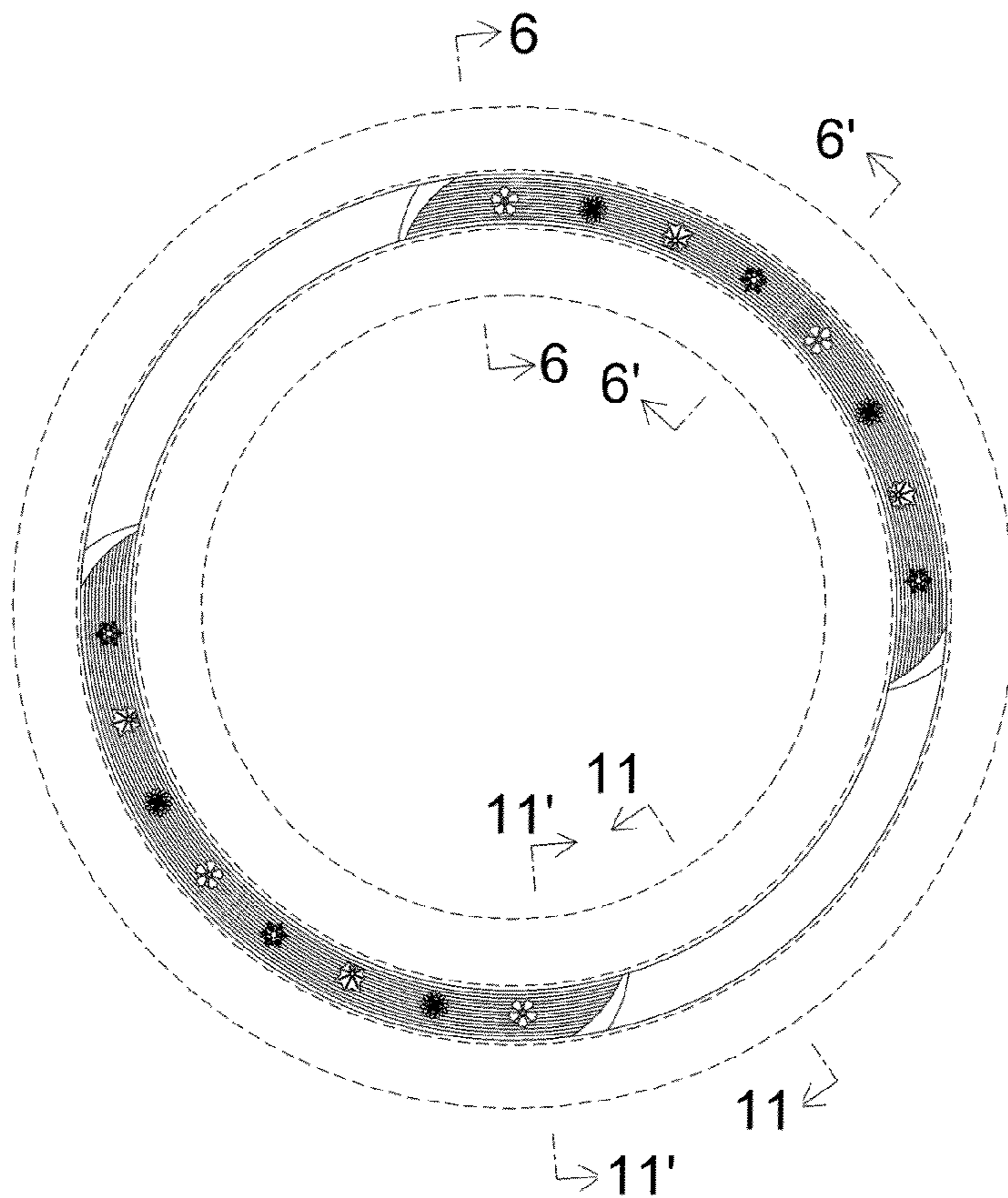

FIG. 1

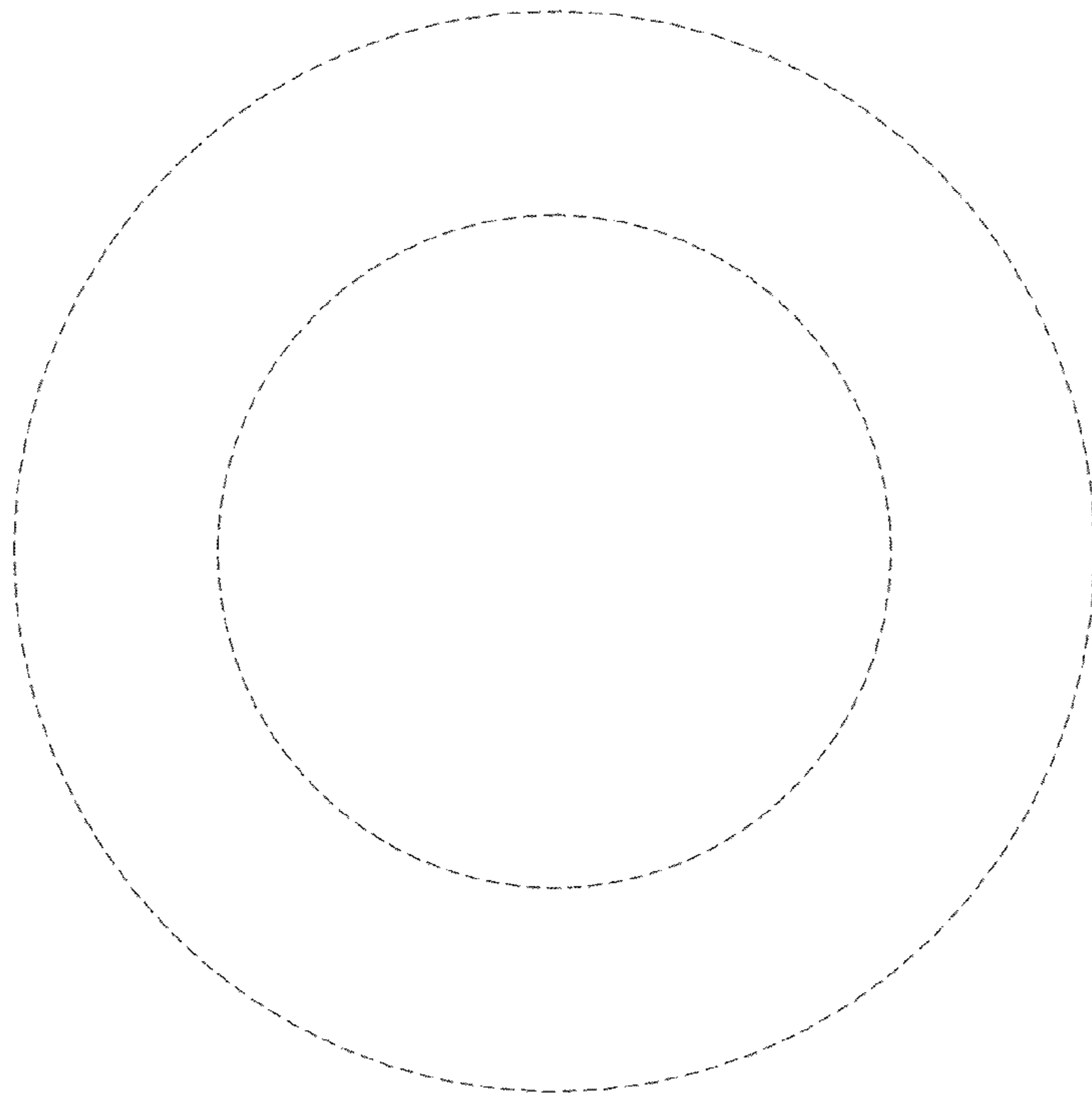

FIG. 2

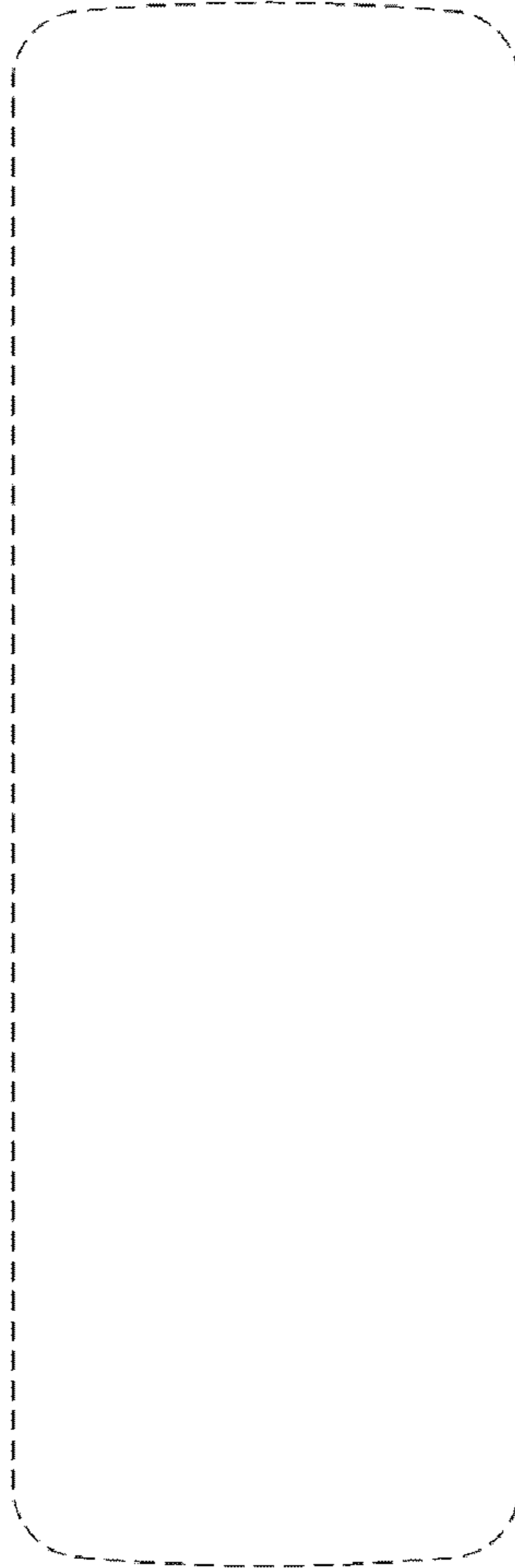

FIG. 3

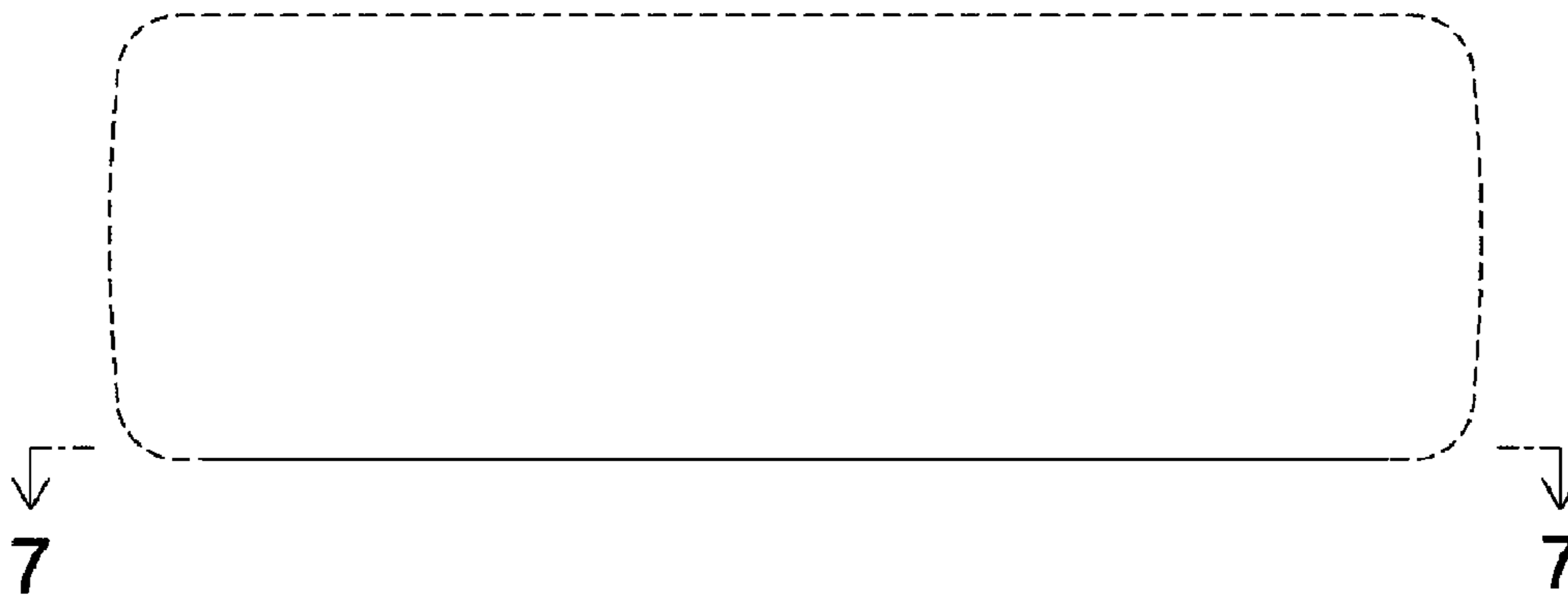

FIG. 4

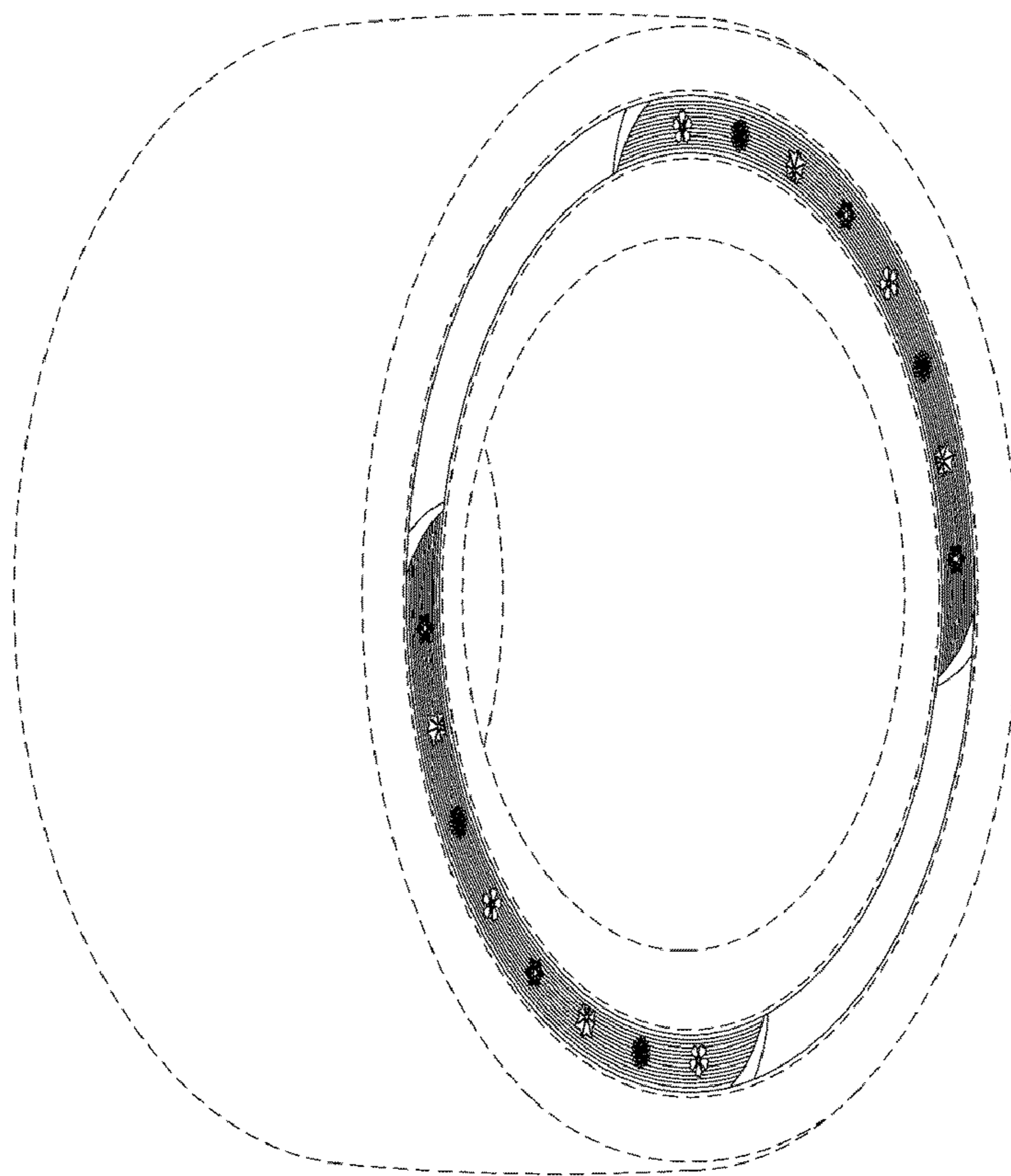

FIG. 5

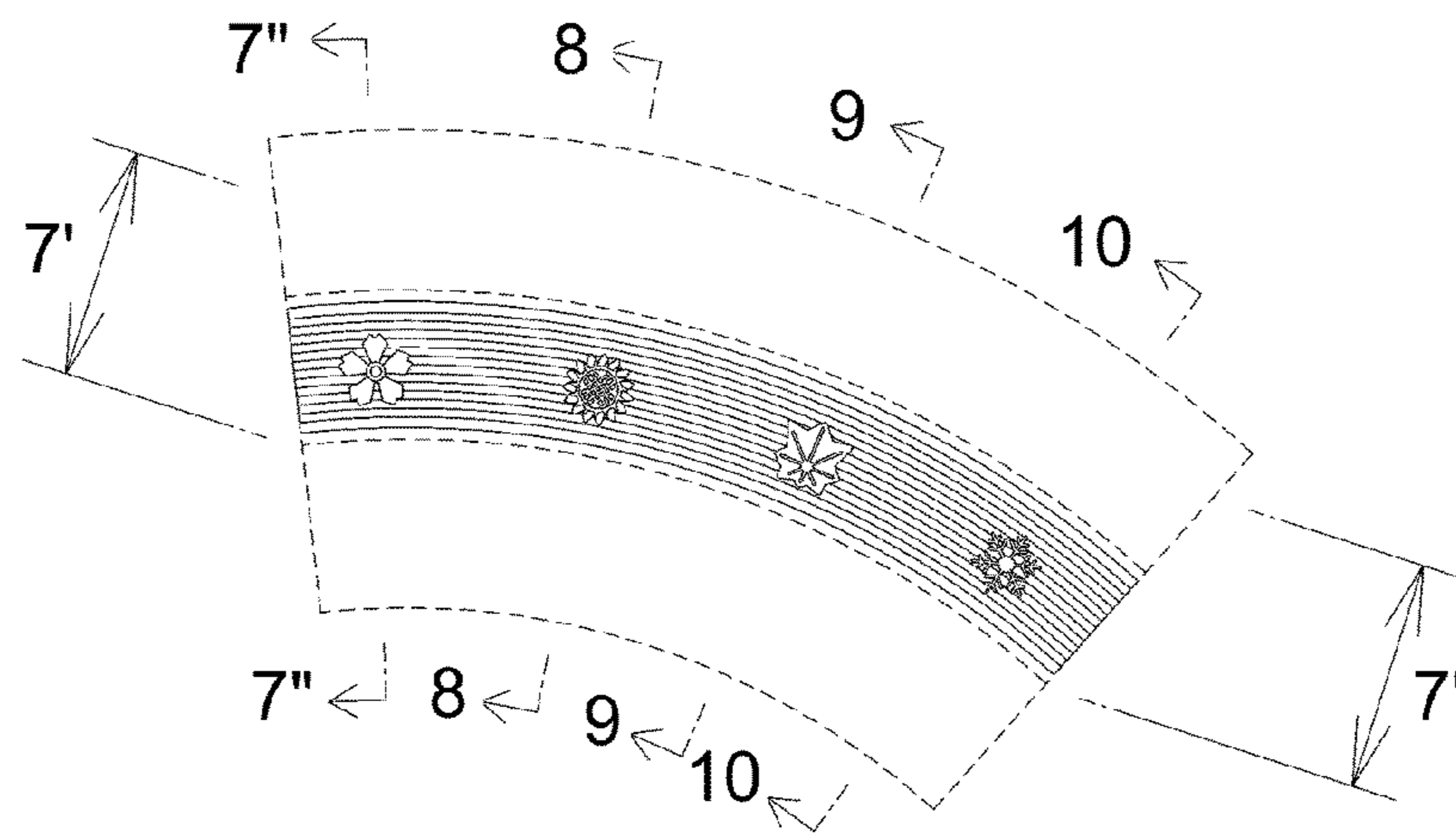

FIG. 6

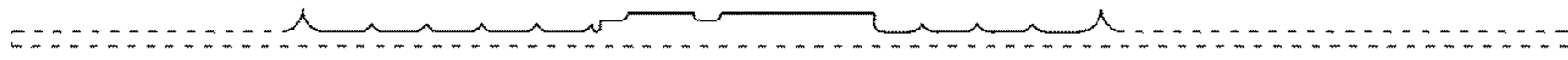

FIG. 7



FIG. 8

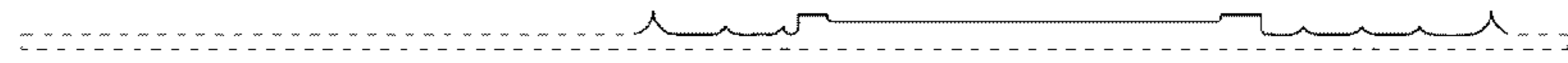

FIG. 9

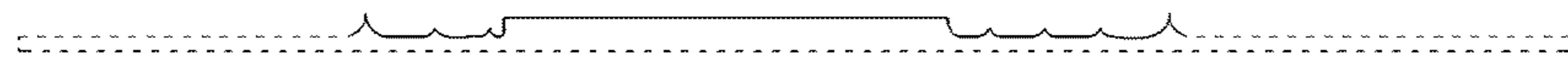

FIG. 10

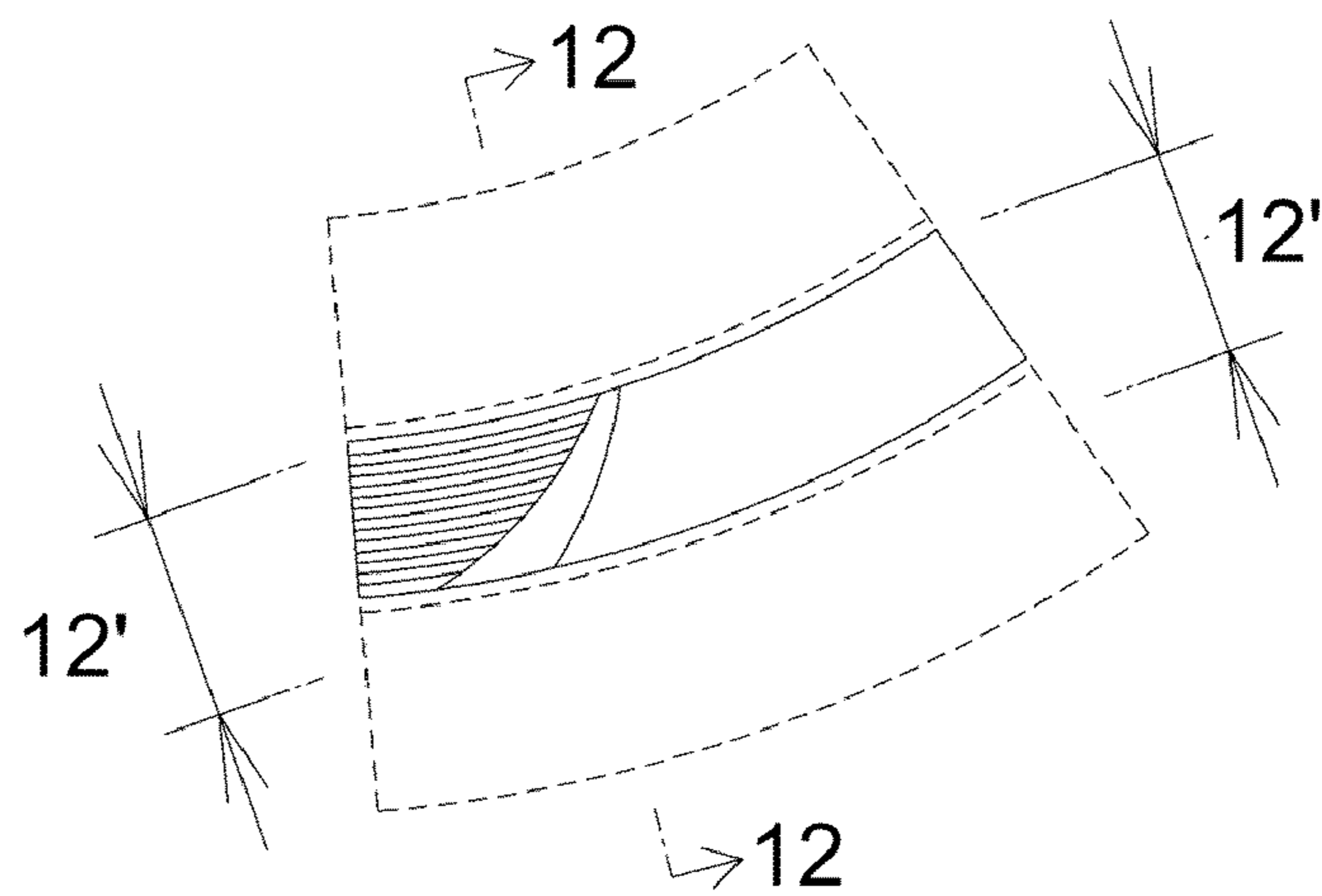

FIG. 11

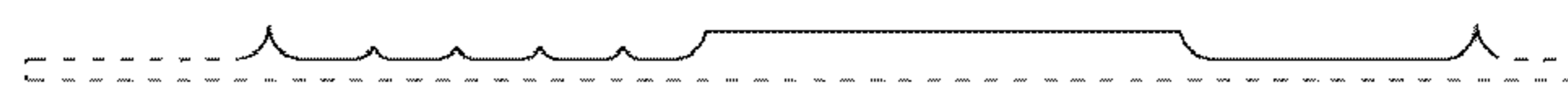

FIG. 12