



US00D656072S

(12) **United States Design Patent**  
**Klein**

(10) **Patent No.:** **US D656,072 S**  
(45) **Date of Patent:** **\*\* Mar. 20, 2012**

(54) **PEDAL FOR A MOTOR VEHICLE**

(75) Inventor: **Thorsten Klein**, Grafenau (DE)

(73) Assignee: **Dr. Ing. h.c. F. Porsche**  
**Aktiengesellschaft**, Stuttgart (DE)

(\*\*) Term: **14 Years**

(21) Appl. No.: **29/367,817**

(22) Filed: **Aug. 13, 2010**

(30) **Foreign Application Priority Data**

Feb. 16, 2010 (EM) ..... 001196216

(51) **LOC (9) Cl.** ..... **12-16**

(52) **U.S. Cl.** ..... **D12/174**

(58) **Field of Classification Search** ..... D12/174;  
74/560-563, 594.4; 280/259, 291; 403/257

See application file for complete search history.

(56) **References Cited**

U.S. PATENT DOCUMENTS

D540,227 S *	4/2007	Doucet	.....	D12/174
D570,764 S *	6/2008	Thomaz	.....	D12/400
D626,901 S *	11/2010	Fallot	.....	D12/174
D629,342 S *	12/2010	Fallot	.....	D12/174
7,954,398 B2 *	6/2011	Lee et al.	.....	74/512

\* cited by examiner

*Primary Examiner* — Melody N Brown

(74) *Attorney, Agent, or Firm* — RatnerPrestia

(57) **CLAIM**

The ornamental design for a pedal for a motor vehicle, as shown and described.

**DESCRIPTION**

FIG. 1 is a perspective view of a pedal for a motor vehicle; FIG. 2 is a front elevation view of the pedal; FIG. 3 is a rear elevation view of the pedal; FIG. 4 is a left side elevation view of the pedal; FIG. 5 is a right side elevation view of the pedal; FIG. 6 is a top plan view of the pedal; and, FIG. 7 is a bottom plan view of the pedal. The broken lines are for illustration purposes only and form no part of the claimed design.

**1 Claim, 4 Drawing Sheets**

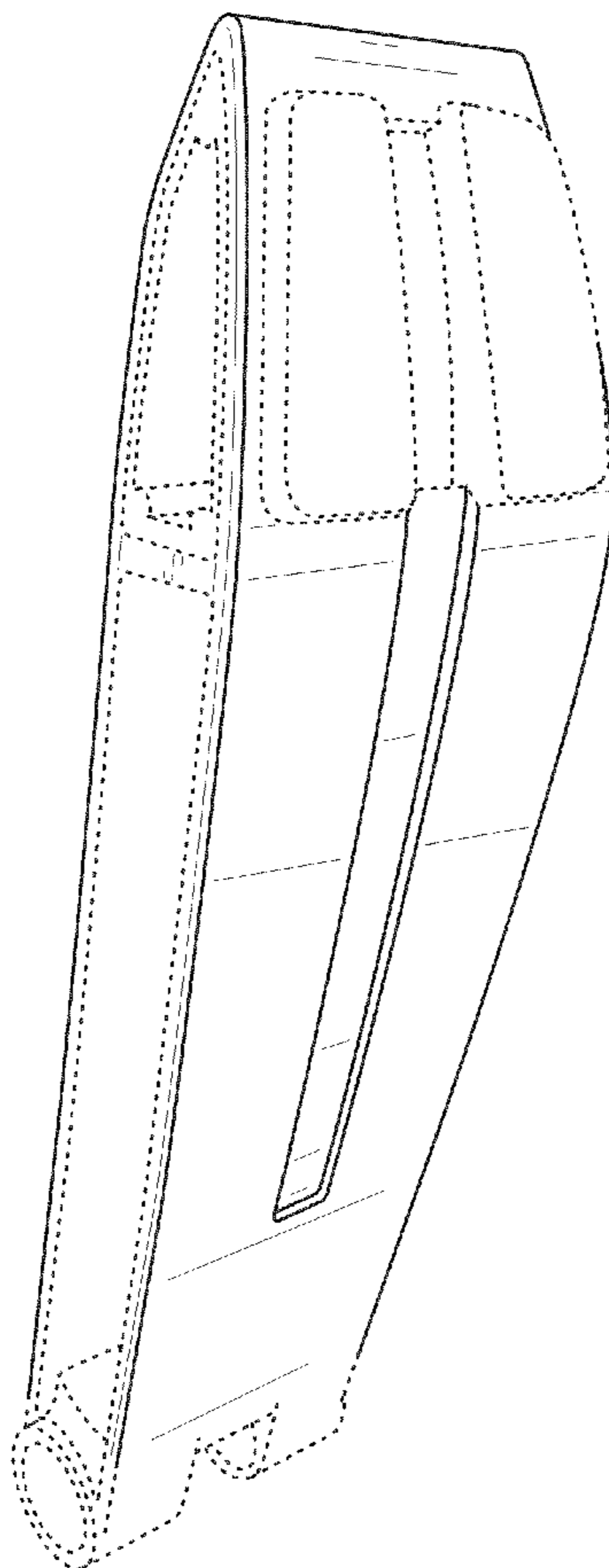

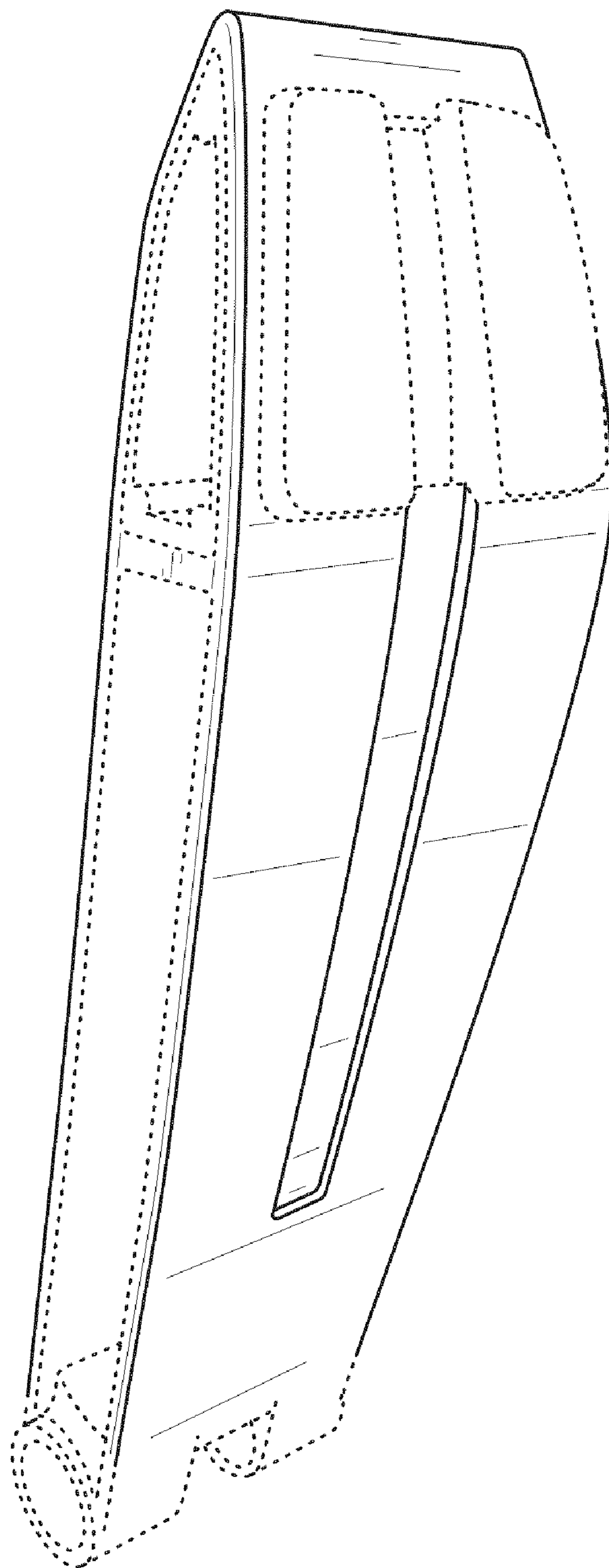

FIG. 1

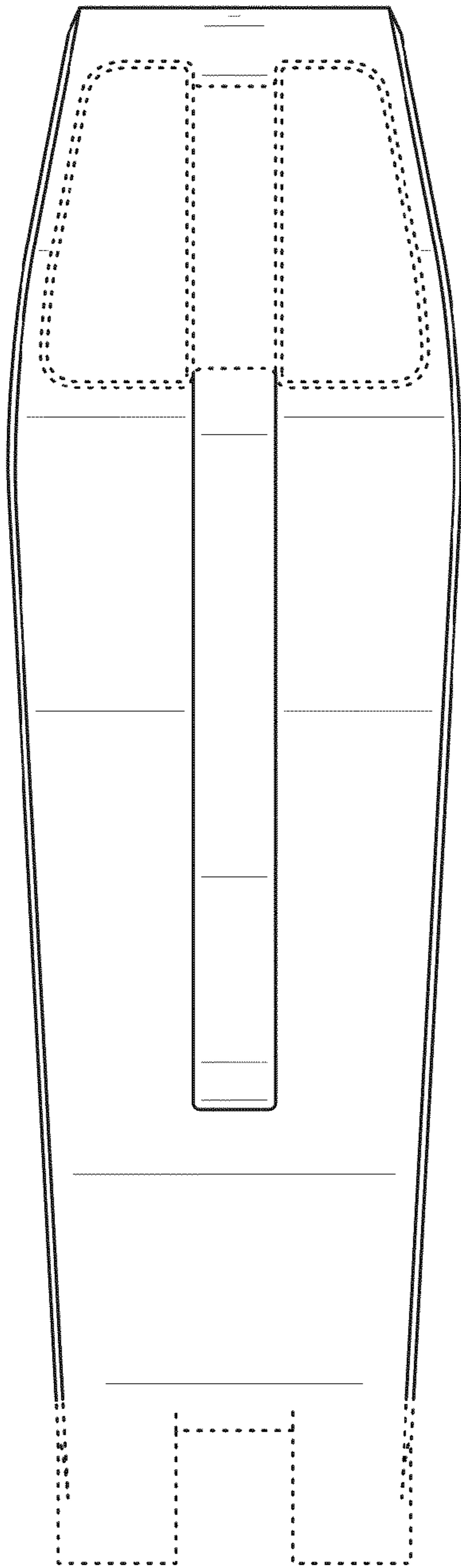

FIG. 2

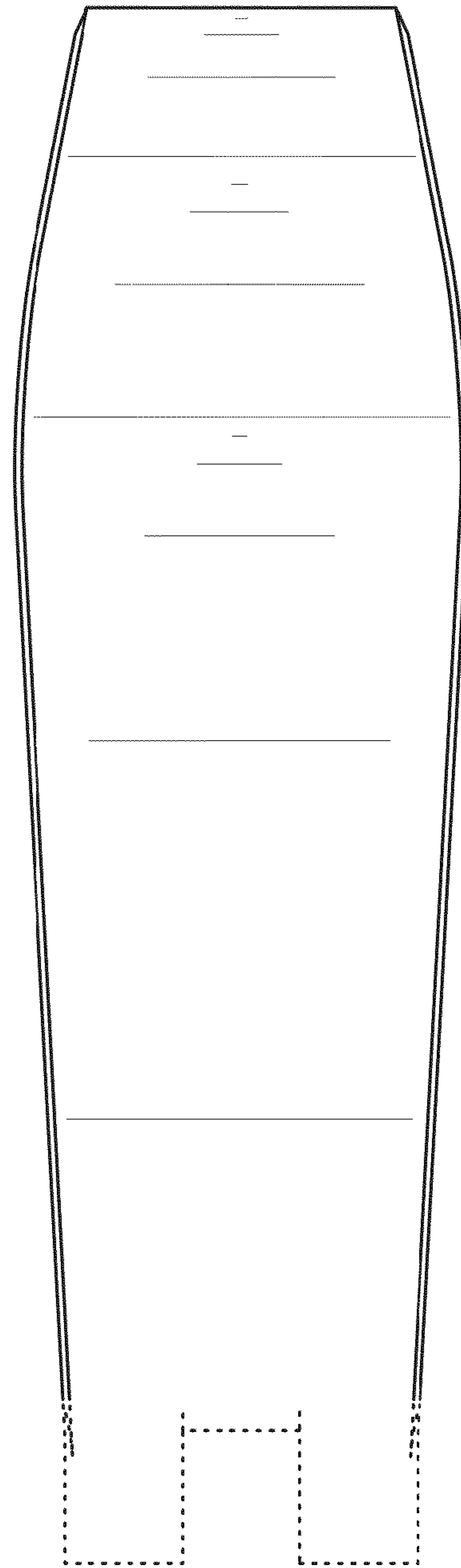

FIG. 3

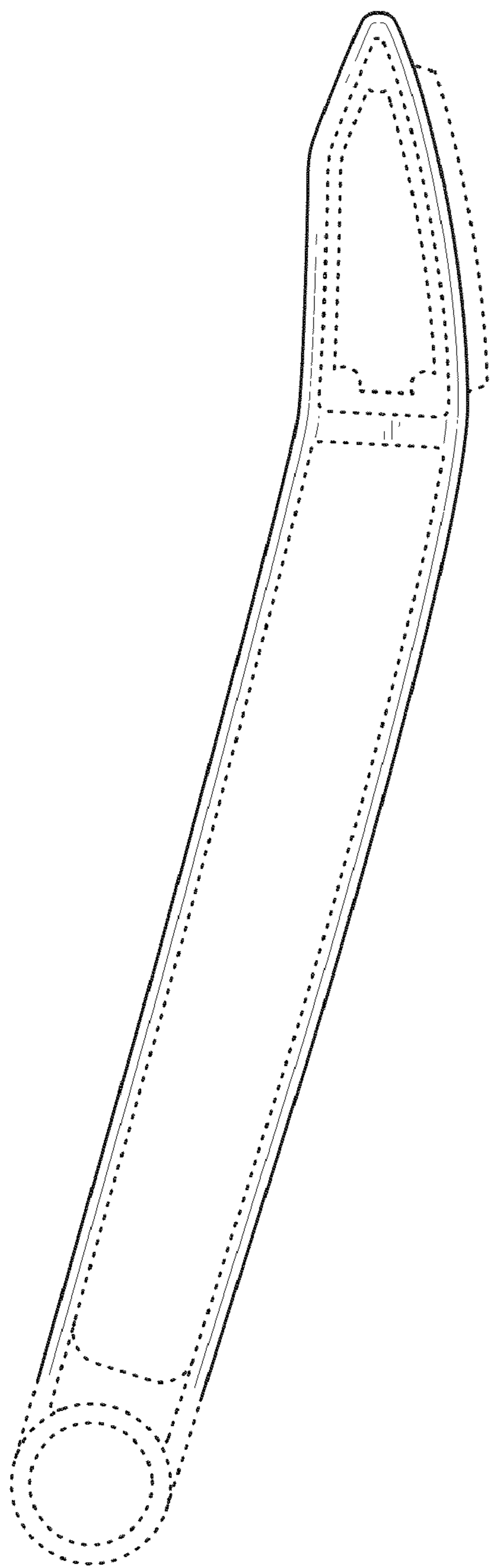

FIG. 4

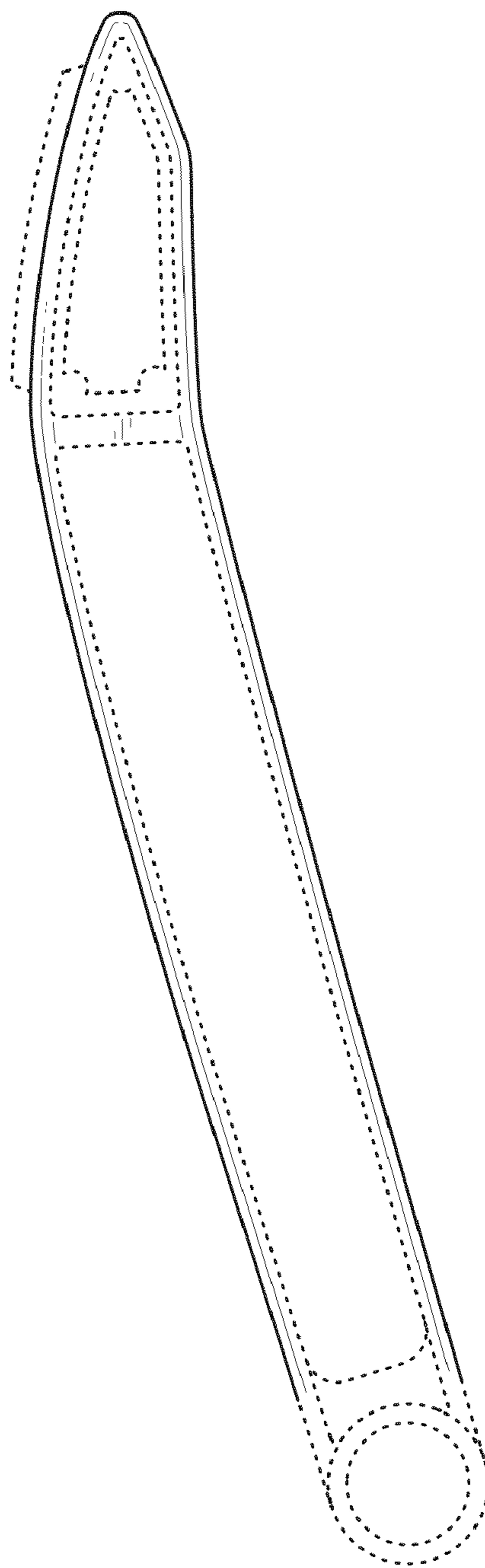

FIG. 5

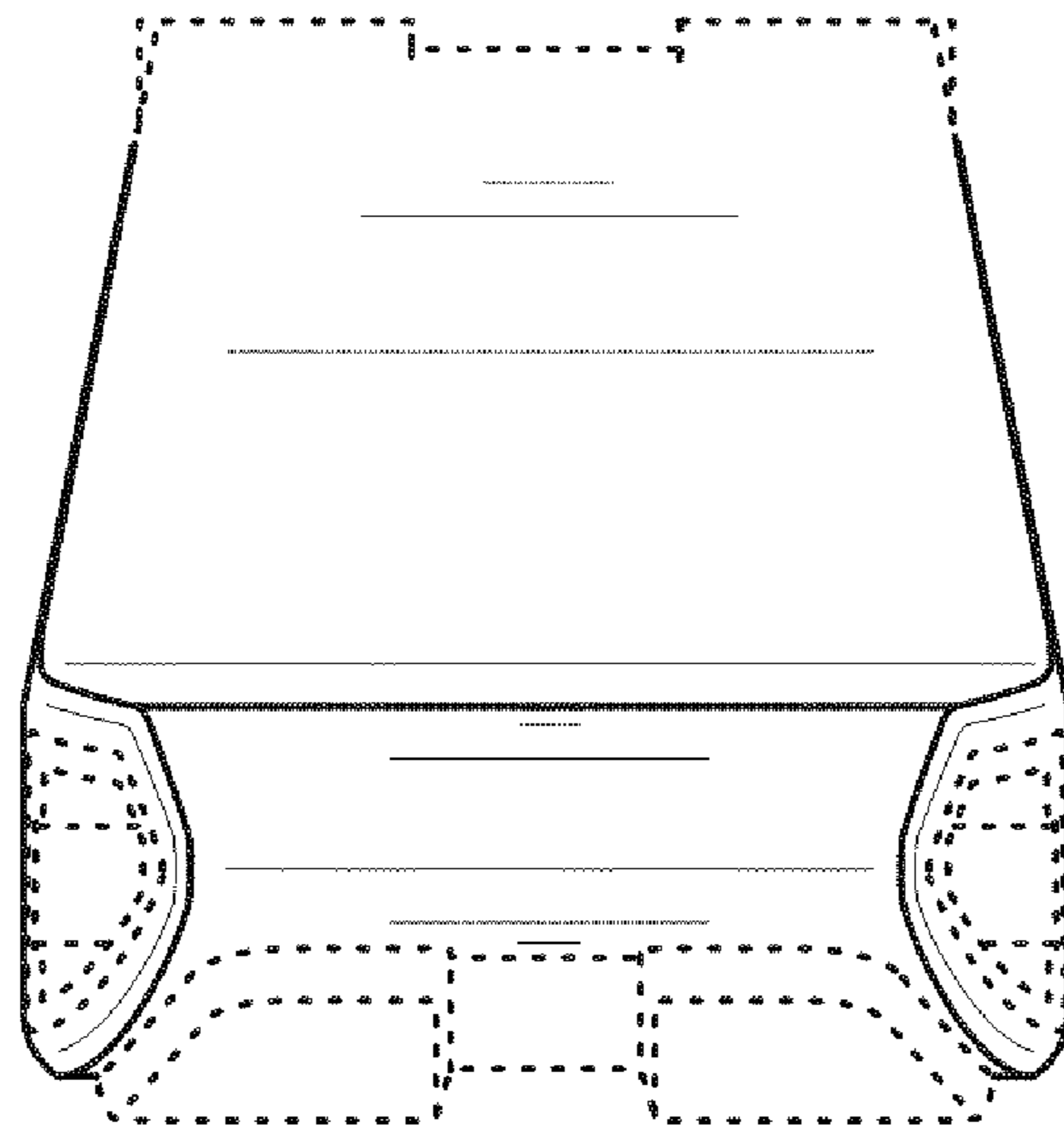

FIG. 6

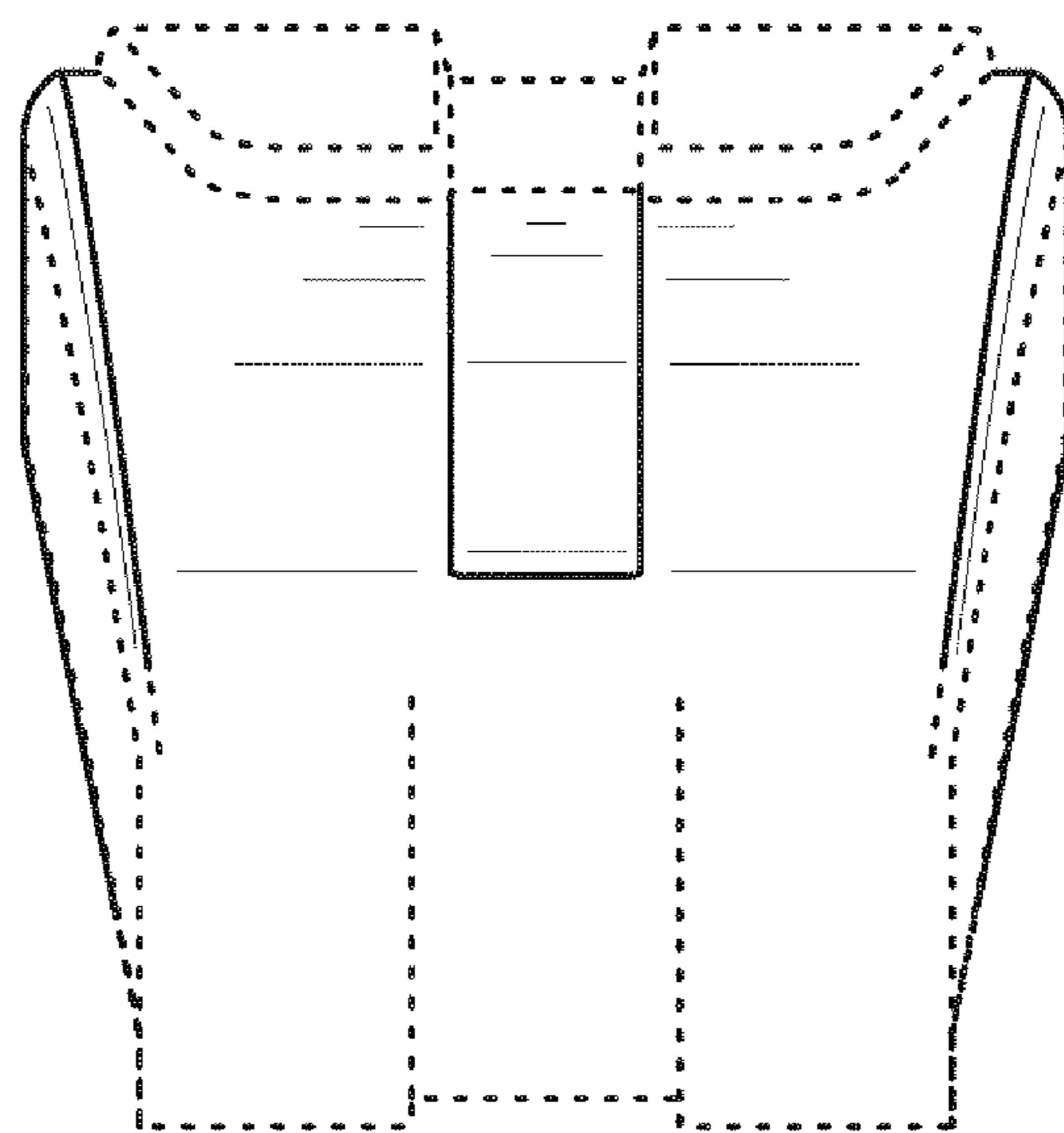

FIG. 7