



US00D655801S

(12) **United States Design Patent**  
**Russell et al.**

(10) **Patent No.:** **US D655,801 S**  
(45) **Date of Patent:** **\*\* Mar. 13, 2012**

(54) **PORTABLE SUBMERSIBLE  
CONDENSER/HEAT EXCHANGER**

(75) Inventors: **Karl Russell**, Hialeah, FL (US);  
**Michael Pruszynski**, Hialeah, FL (US);  
**Richard Koldewey**, Hialeah, FL (US)

(73) Assignee: **CPS Products, Inc.**, Hialeah, FL (US)

(\*\*) Term: **14 Years**

(21) Appl. No.: **29/396,257**

(22) Filed: **Jun. 28, 2011**

(51) **LOC (9) Cl.** ..... **23-03**

(52) **U.S. Cl.** ..... **D23/323**

(58) **Field of Classification Search** ..... D23/314,  
D23/317, 316, 318, 319, 321, 322, 323, 324,  
D23/325, 329, 330, 335, 341; 416/244 R,  
416/247 R; 165/67; D13/199

See application file for complete search history.

(56) **References Cited**

U.S. PATENT DOCUMENTS

1,896,081 A 2/1933 Hampson  
2,067,004 A \* 1/1937 Spengler ..... 165/67  
2,223,152 A 11/1940 Nagin  
D208,076 S \* 7/1967 Lindsey et al. .... D23/324

3,448,792 A 6/1969 Lawrence  
4,365,483 A 12/1982 Binger  
5,377,499 A 1/1995 Zugibe  
D413,659 S \* 9/1999 Swartz ..... D23/316  
2010/0329908 A1 12/2010 Martinez et al.

\* cited by examiner

*Primary Examiner* — T. Chase Nelson

*Assistant Examiner* — Ania Aman

(74) *Attorney, Agent, or Firm* — Malin Haley DiMaggio  
Bowen & Lhota, P.A.

(57) **CLAIM**

The ornamental design for a portable submersible condenser/  
heat exchanger, as shown and described.

**DESCRIPTION**

FIG. 1 is a perspective view of the portable submersible  
condenser/heat exchanger, showing the new design;  
FIG. 2 is a side elevation view of the portable submersible  
condenser/heat exchanger;  
FIG. 3 is a top elevation view of the portable submersible  
condenser/heat exchanger;  
FIG. 4 is a bottom elevation view of the portable submersible  
condenser/heat exchanger; and,  
FIG. 5 is another perspective view of the portable submersible  
condenser/heat exchanger, showing the bottom thereof.

**1 Claim, 4 Drawing Sheets**

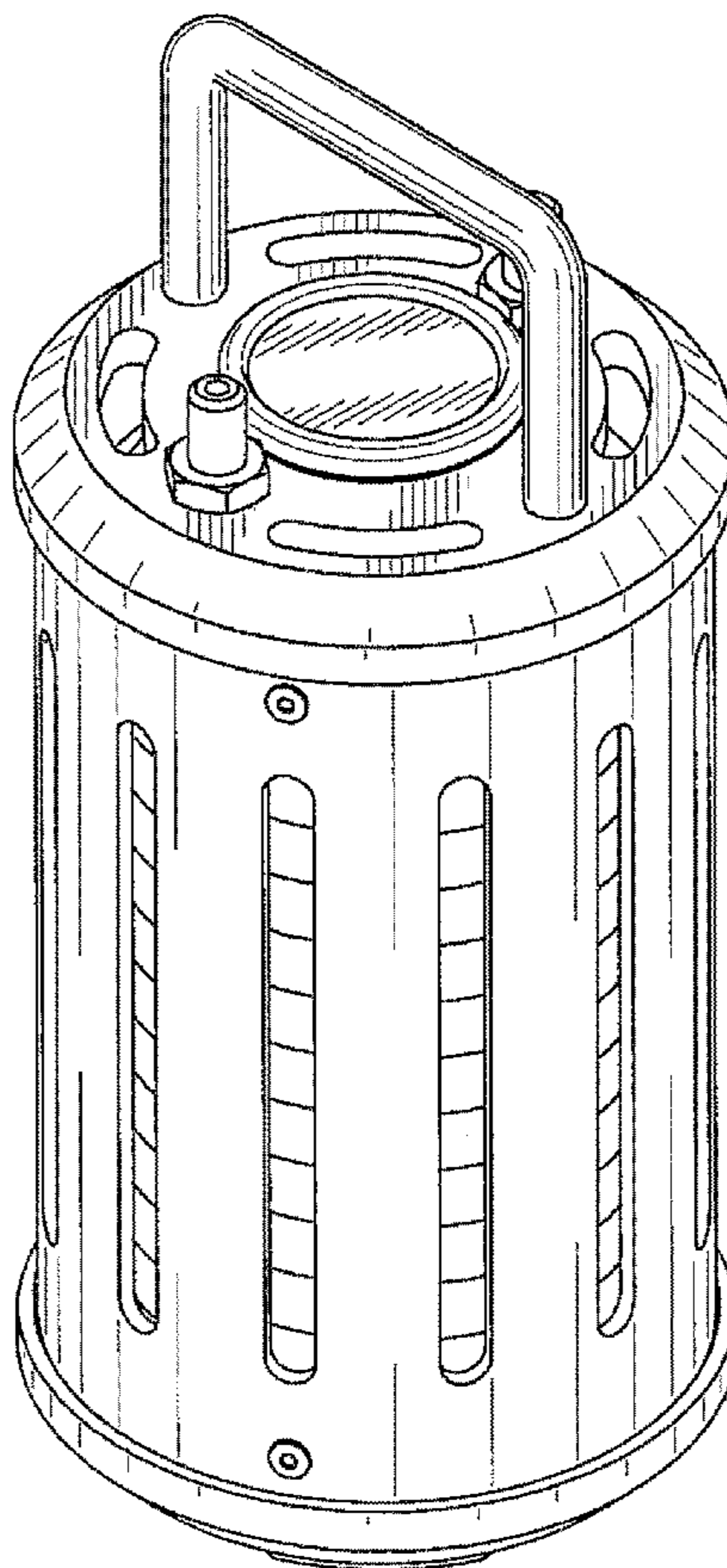

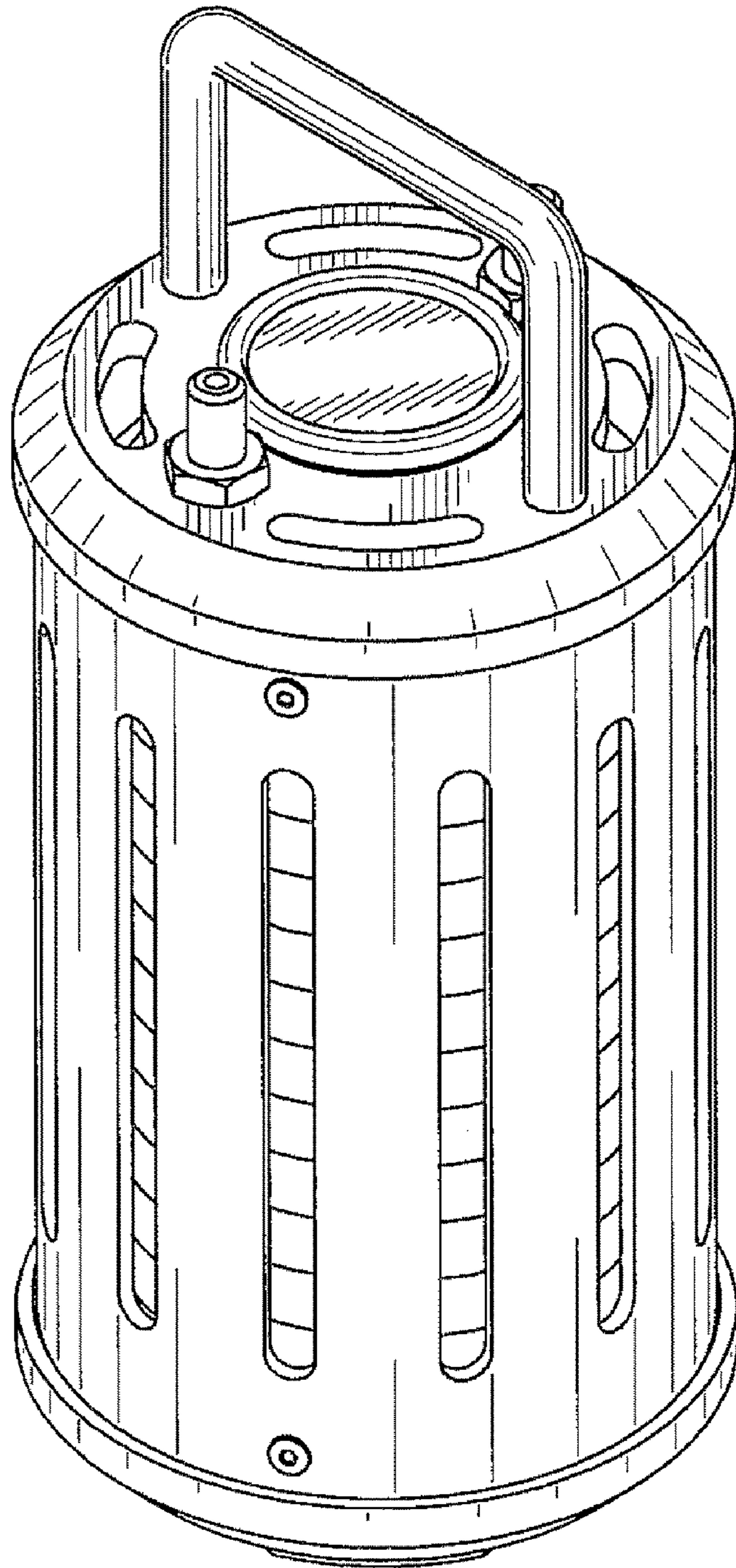

FIG. 1

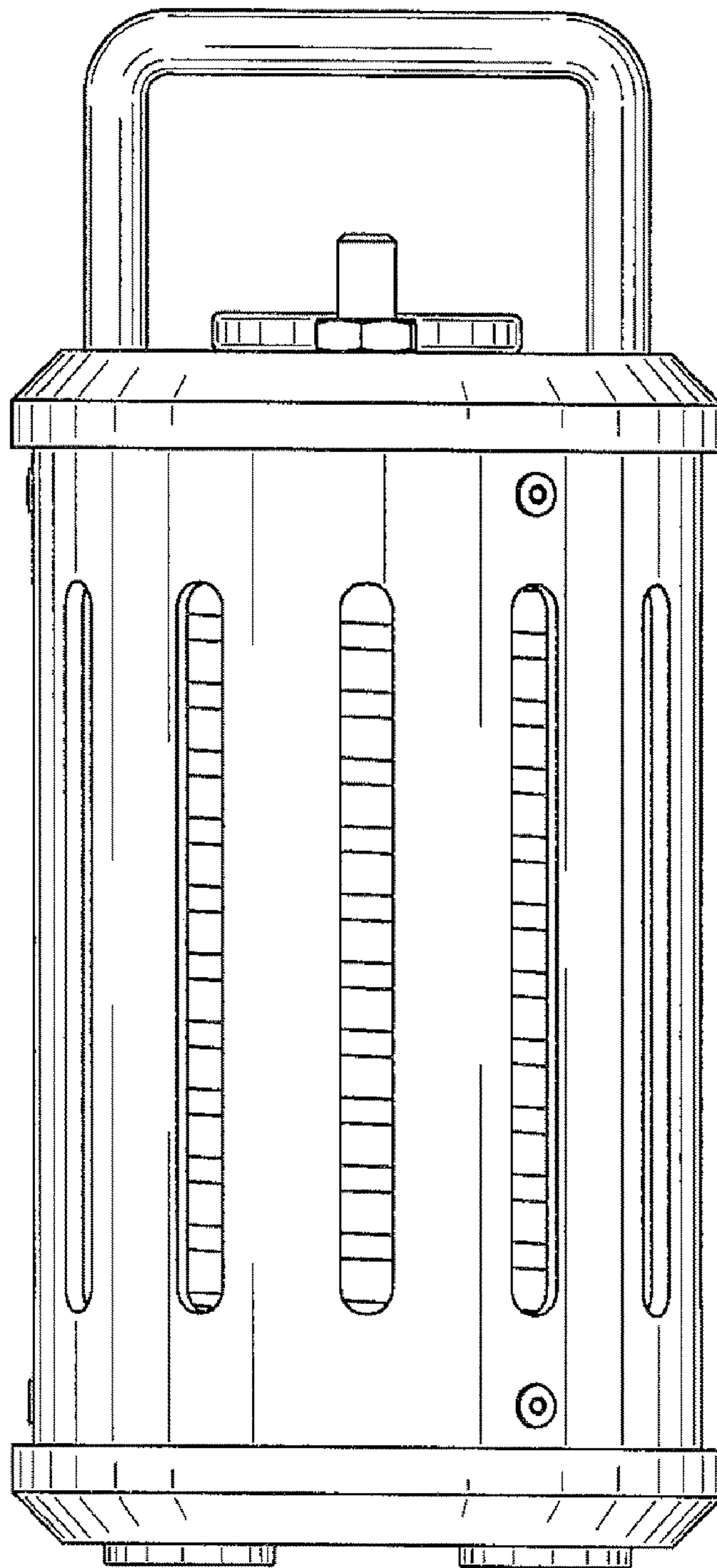

FIG. 2

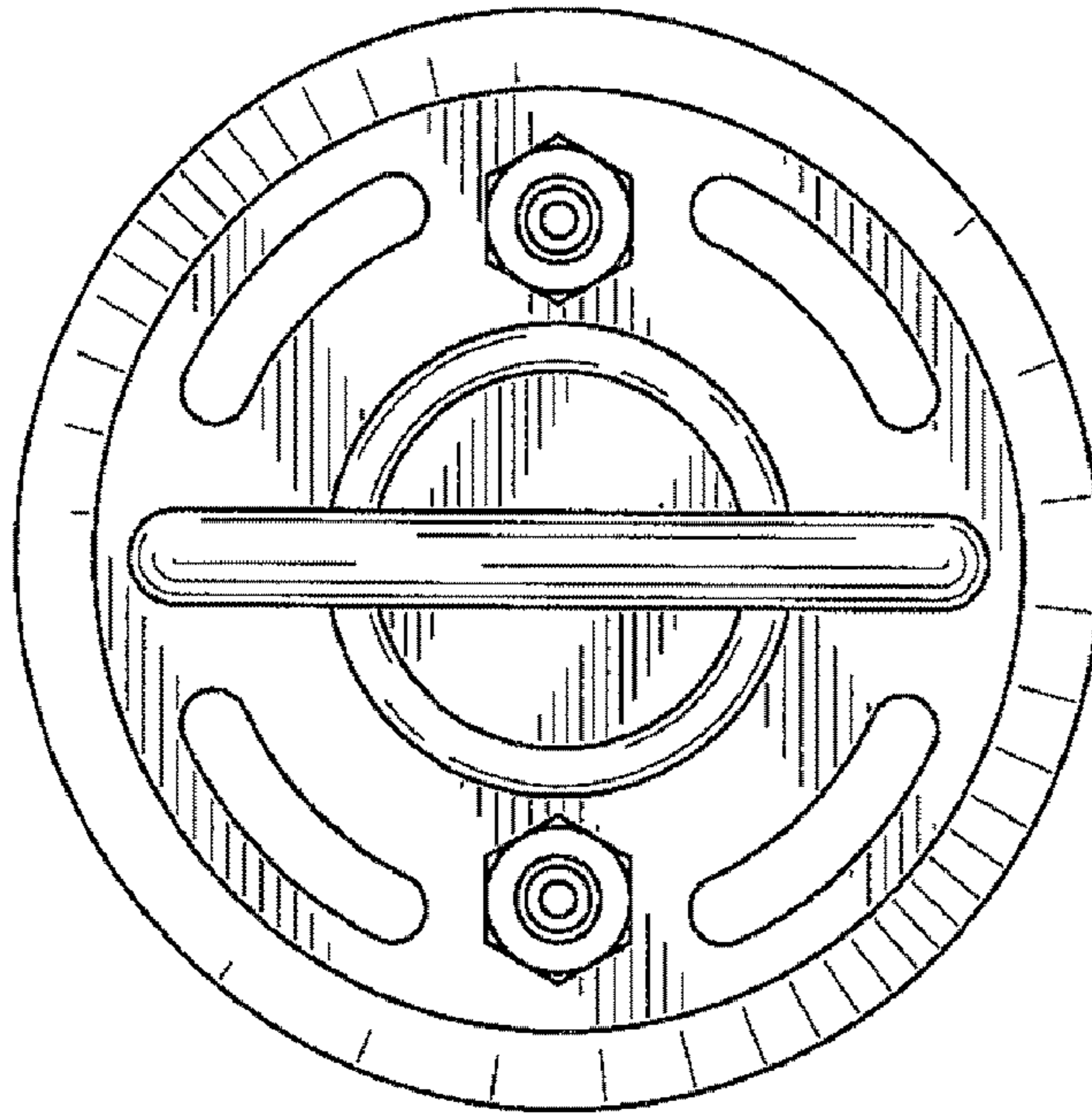

FIG. 3

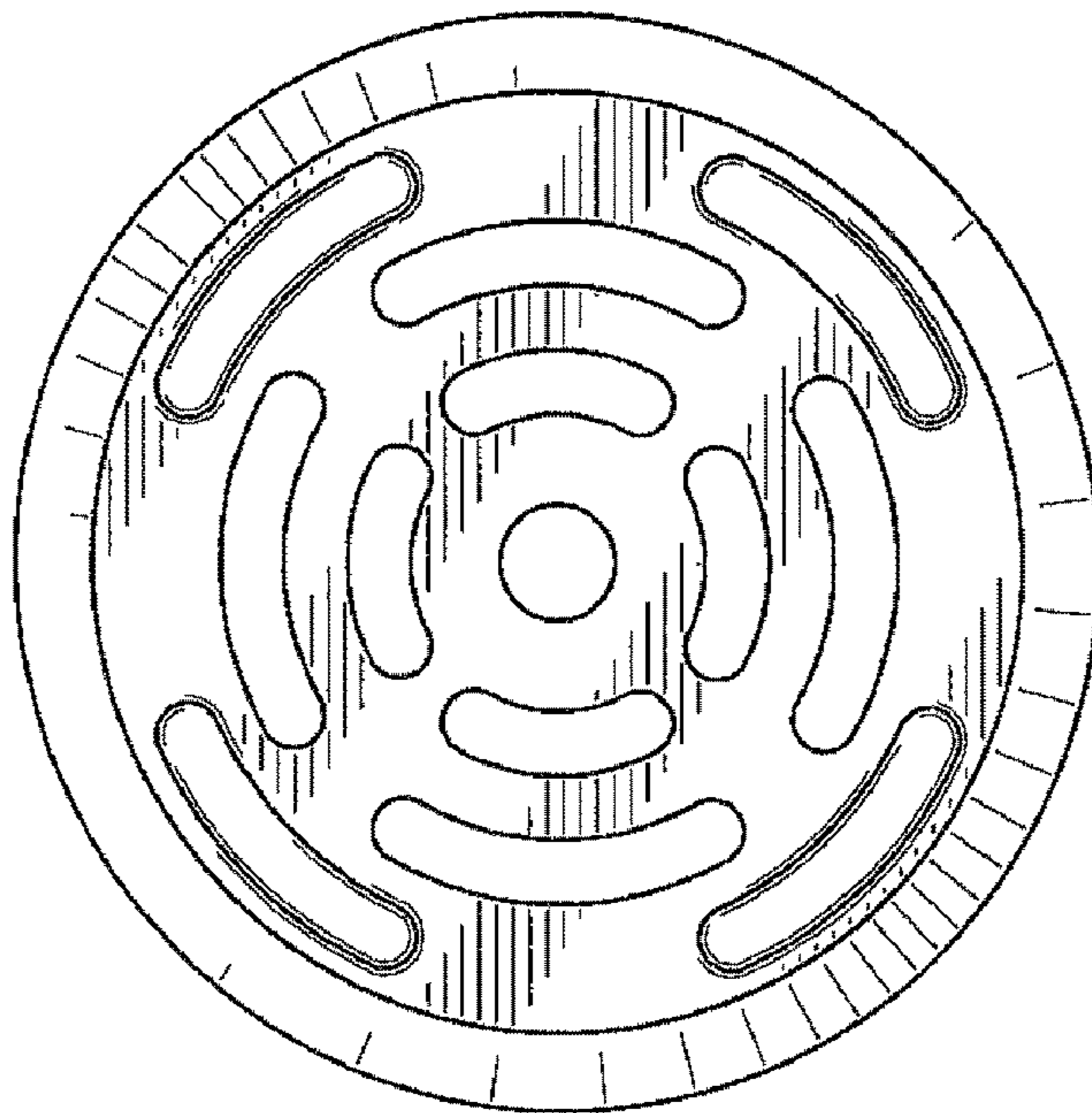

FIG. 4

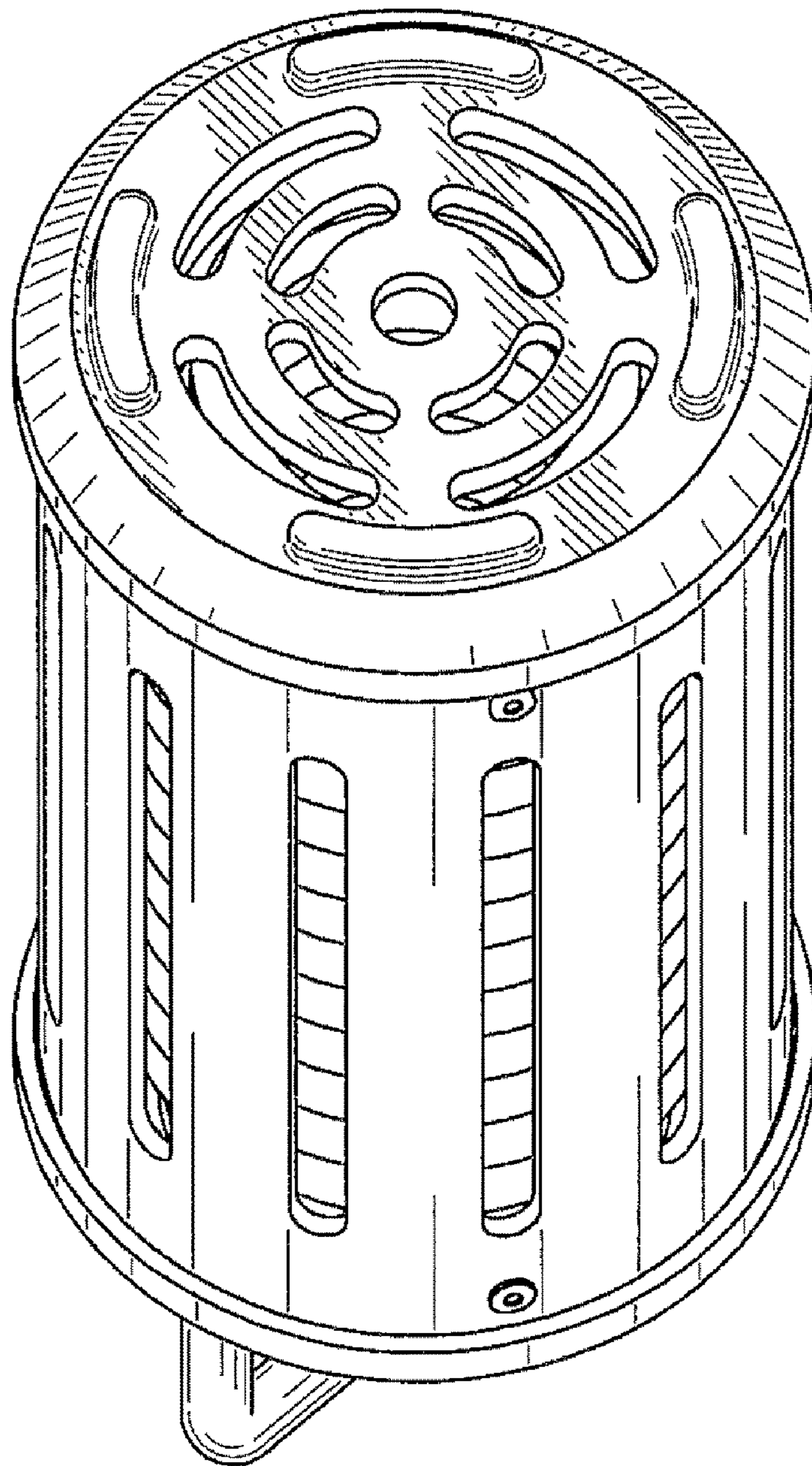

FIG. 5