



US00D655423S

(12) **United States Design Patent**  
**Nielsen et al.**

(10) **Patent No.:** **US D655,423 S**  
(45) **Date of Patent:** **\*\* Mar. 6, 2012**

(54) **FLUIDIC DISPENSE DEVICE**

(75) Inventors: **Jeffrey A Nielsen**, Corvallis, OR (US);  
**Christie Dudenhoefer**, Corvallis, OR  
(US); **James Hankins**, Corvallis, OR  
(US); **Mark W Woodruff**, Corvallis, OR  
(US); **Robert Moline**, Albany, OR (US);  
**Kenneth Duda**, Corvallis, OR (US);  
**Darrel E Pozzesi**, Corvallis, OR (US);  
**Matthew C Still**, Corvallis, OR (US)

(73) Assignee: **Hewlett-Packard Development  
Company, L.P.**, Houston, TX (US)

(\*\*) Term: **14 Years**

(21) Appl. No.: **29/390,737**

(22) Filed: **Apr. 28, 2011**

(51) **LOC (9) Cl.** ..... **24-01**

(52) **U.S. Cl.** ..... **D24/216; D24/225**

(58) **Field of Classification Search** ..... D24/216-232,  
D24/186; D10/81; 422/500, 502, 503, 554;  
435/287.1, 288.1, 288.2, 288.4, 287.9, 288.3;  
359/396, 397, 398

See application file for complete search history.

(56) **References Cited**

**U.S. PATENT DOCUMENTS**

D243,543 S \* 3/1977 Fadler et al. .... D24/216  
D258,388 S \* 2/1981 Parker ..... D24/225

D325,518 S \* 4/1992 Matkovich ..... D24/216  
D340,289 S \* 10/1993 Gerber ..... D24/223  
5,731,212 A \* 3/1998 Gavin et al. .... 436/526  
D456,082 S \* 4/2002 Bouse et al. .... D24/223  
D606,664 S \* 12/2009 Jacono et al. .... D24/225  
D621,060 S \* 8/2010 Handique ..... D24/225  
D637,310 S \* 5/2011 Barbieux et al. .... D24/216  
D639,975 S \* 6/2011 Doyle et al. .... D24/225  
D640,389 S \* 6/2011 Francis et al. .... D24/225

\* cited by examiner

*Primary Examiner* — Anhdao Doan

(74) *Attorney, Agent, or Firm* — Walter W. Karnstein

(57) **CLAIM**

The ornamental design for a fluidic dispense device, substantially as shown and described.

**DESCRIPTION**

FIG. 1 is a top-right perspective view of the design for the fluidic dispense device;

FIG. 2 is a bottom-right perspective view thereof;

FIG. 3 is a left side view thereof;

FIG. 4 is a right side view thereof;

FIG. 5 is a rear view thereof;

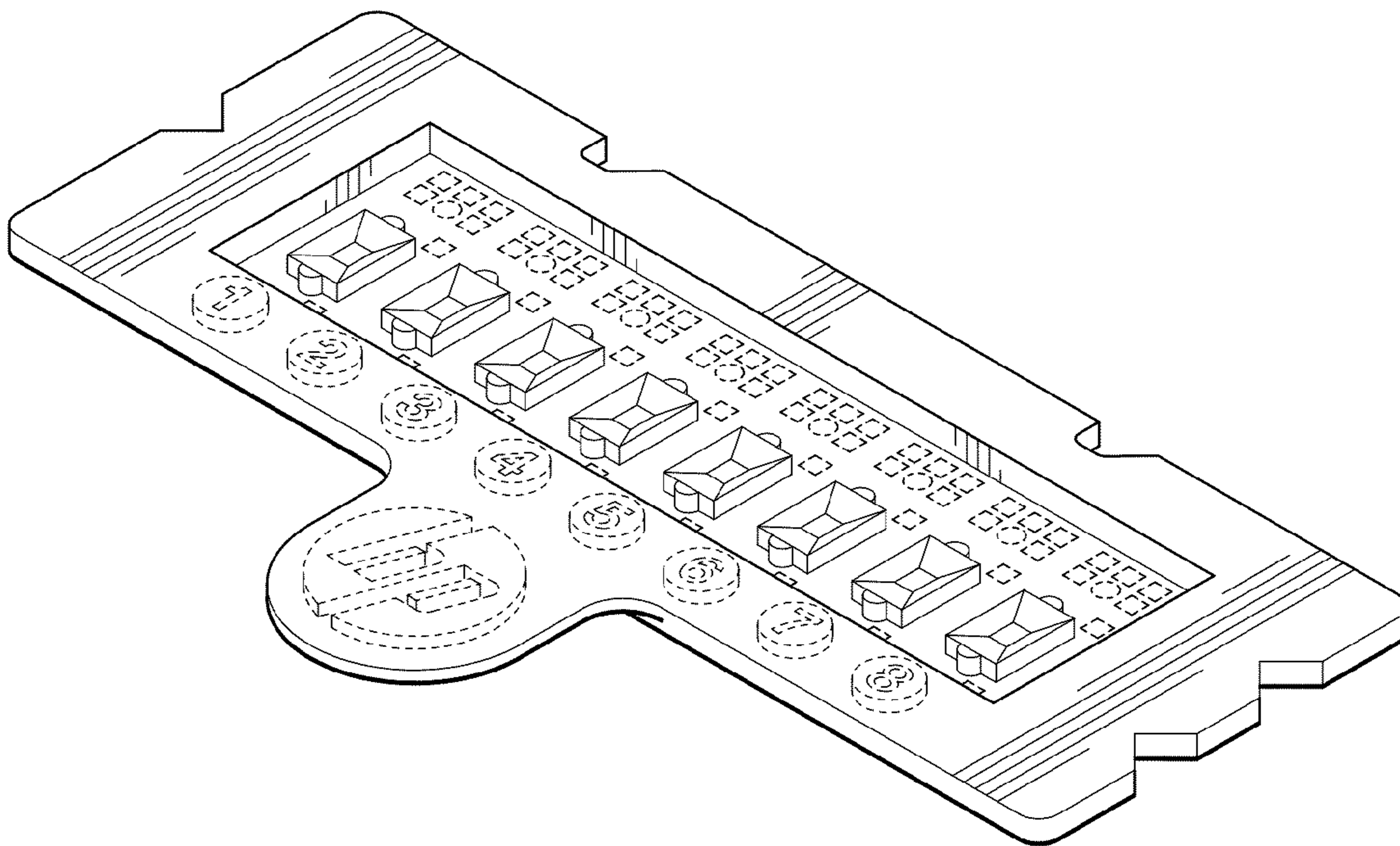
FIG. 6 is a front view thereof;

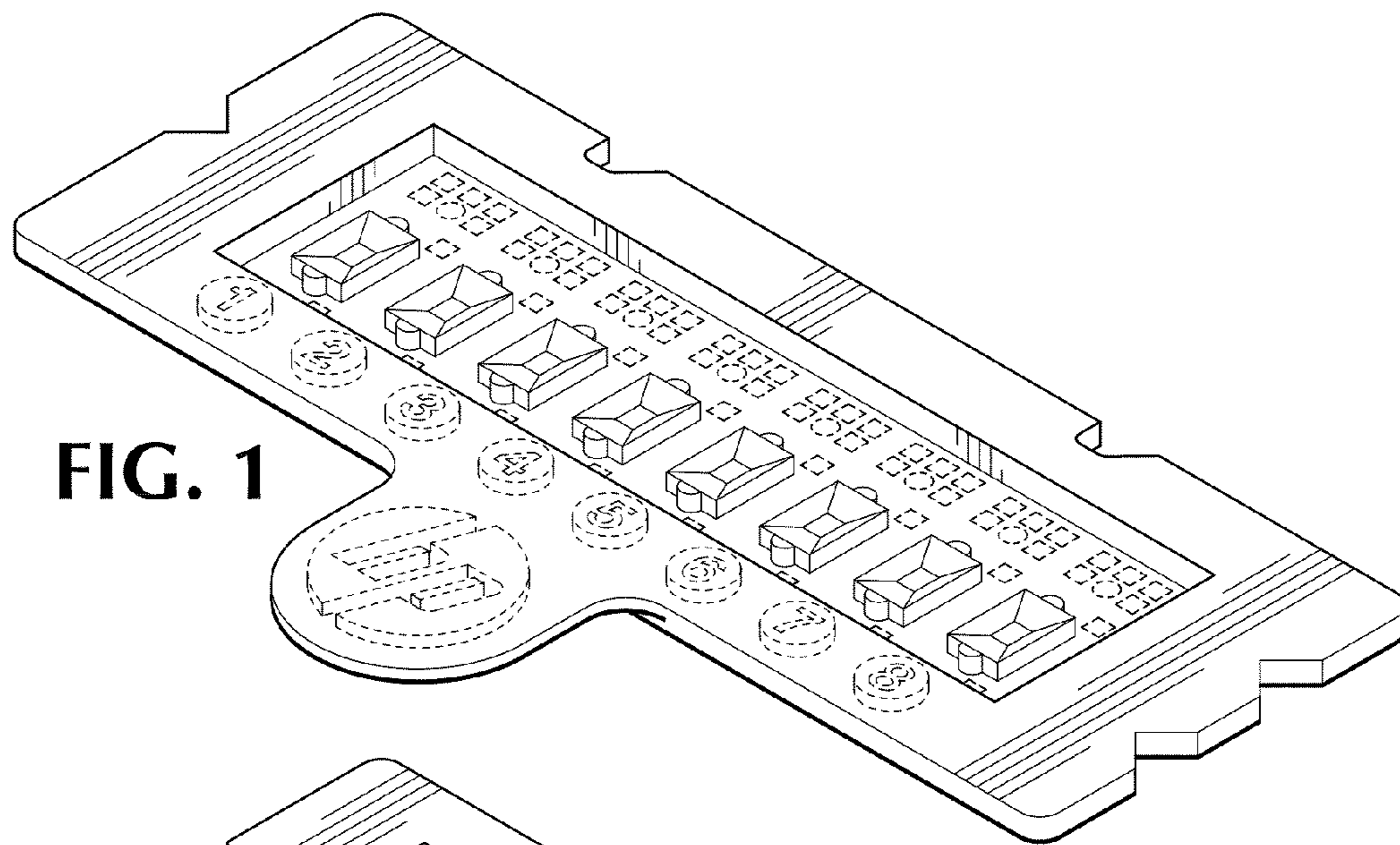
FIG. 7 is a top plan view thereof; and,

FIG. 8 is a bottom view thereof.

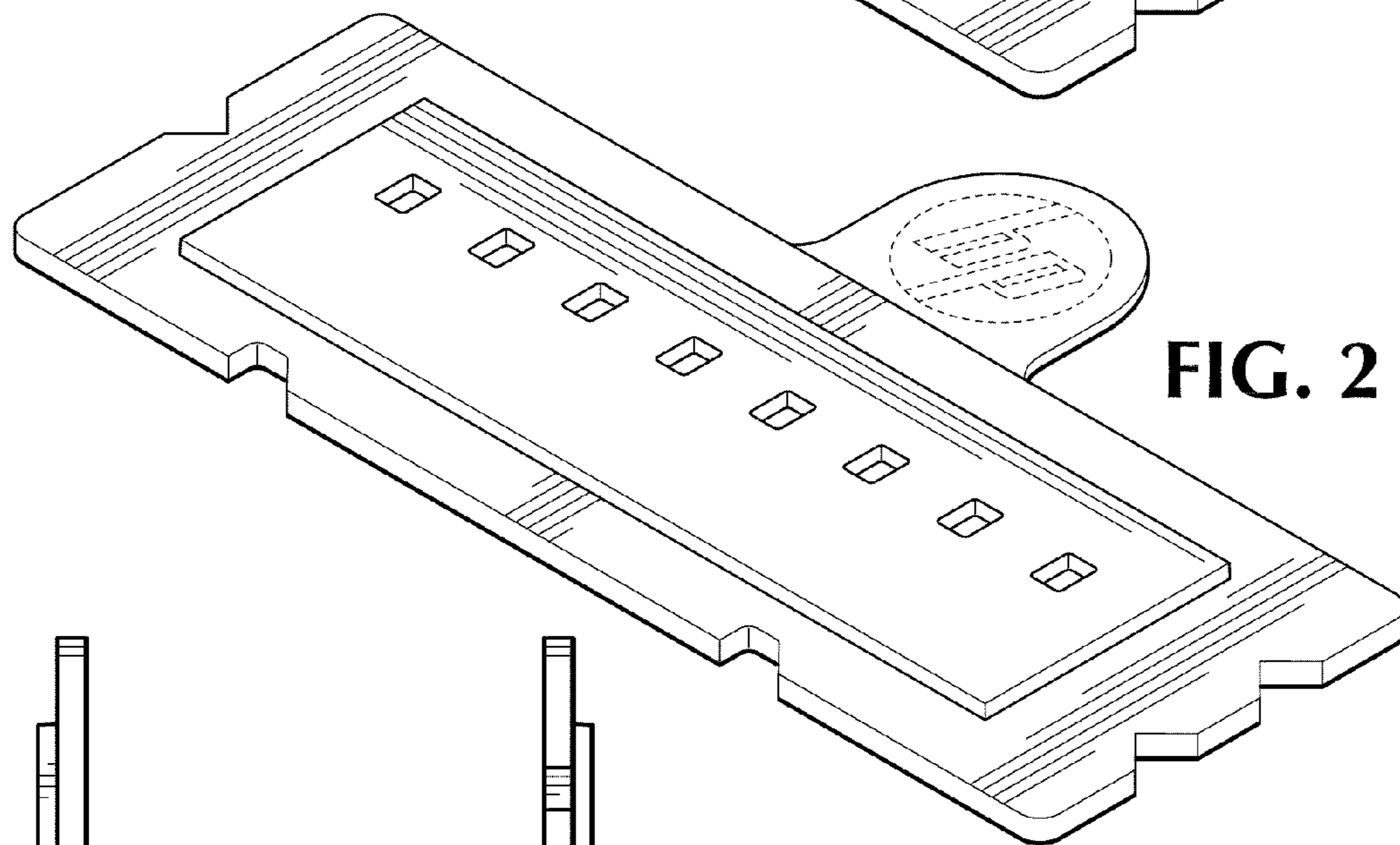
The portions shown in broken lines are for illustrative purposes only and form no part of the claimed design.

**1 Claim, 2 Drawing Sheets**

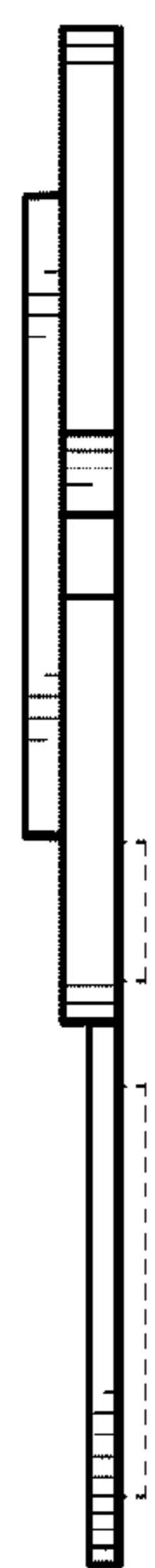




**FIG. 1**



**FIG. 2**



**FIG. 3**



**FIG. 4**



FIG. 5

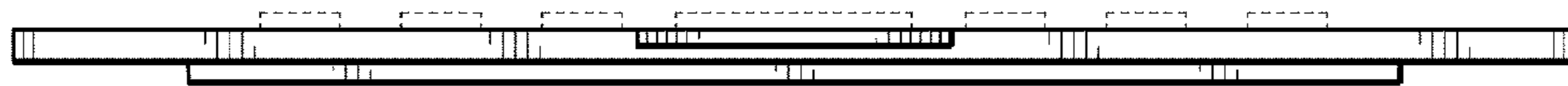


FIG. 6

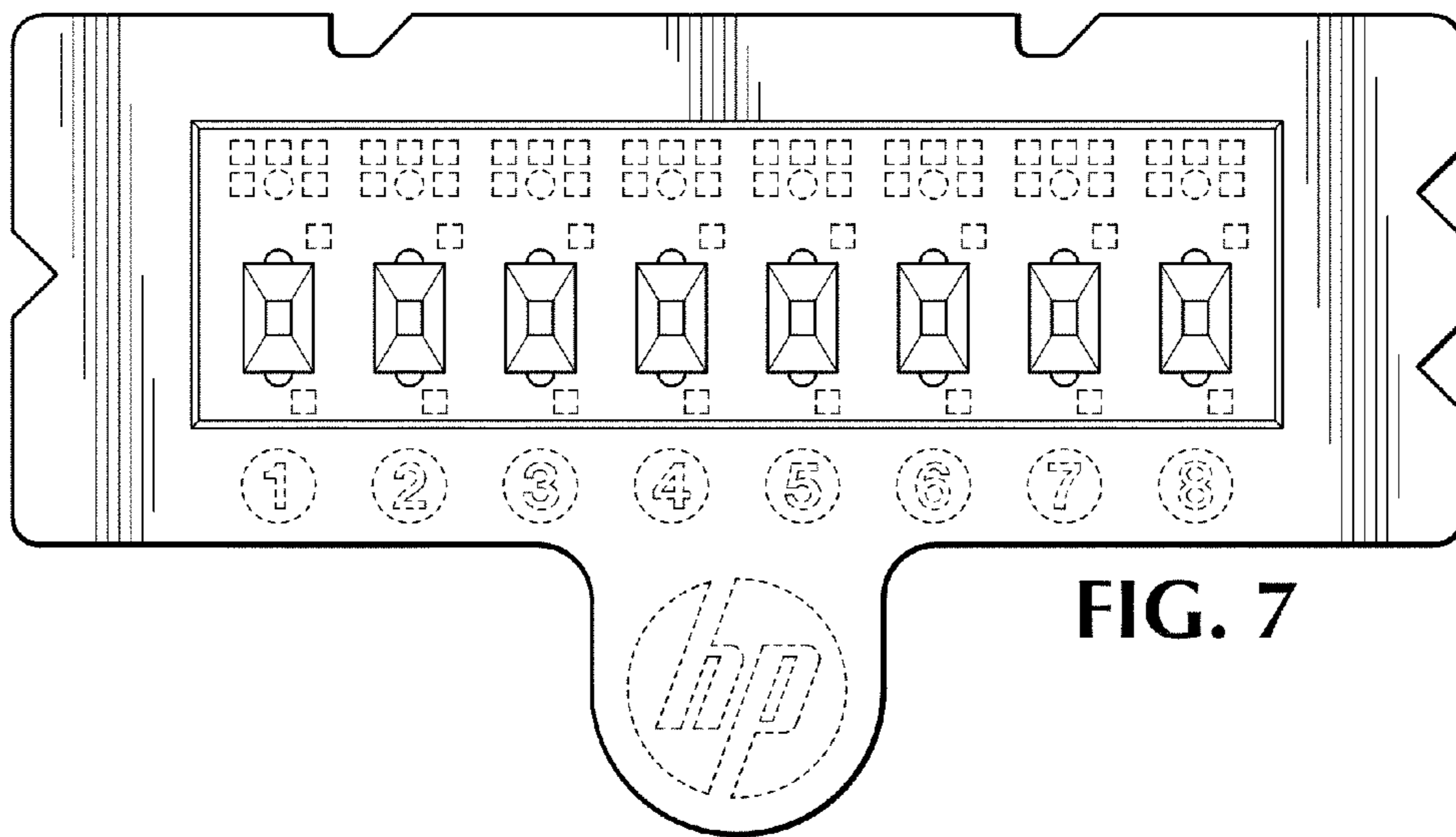


FIG. 7

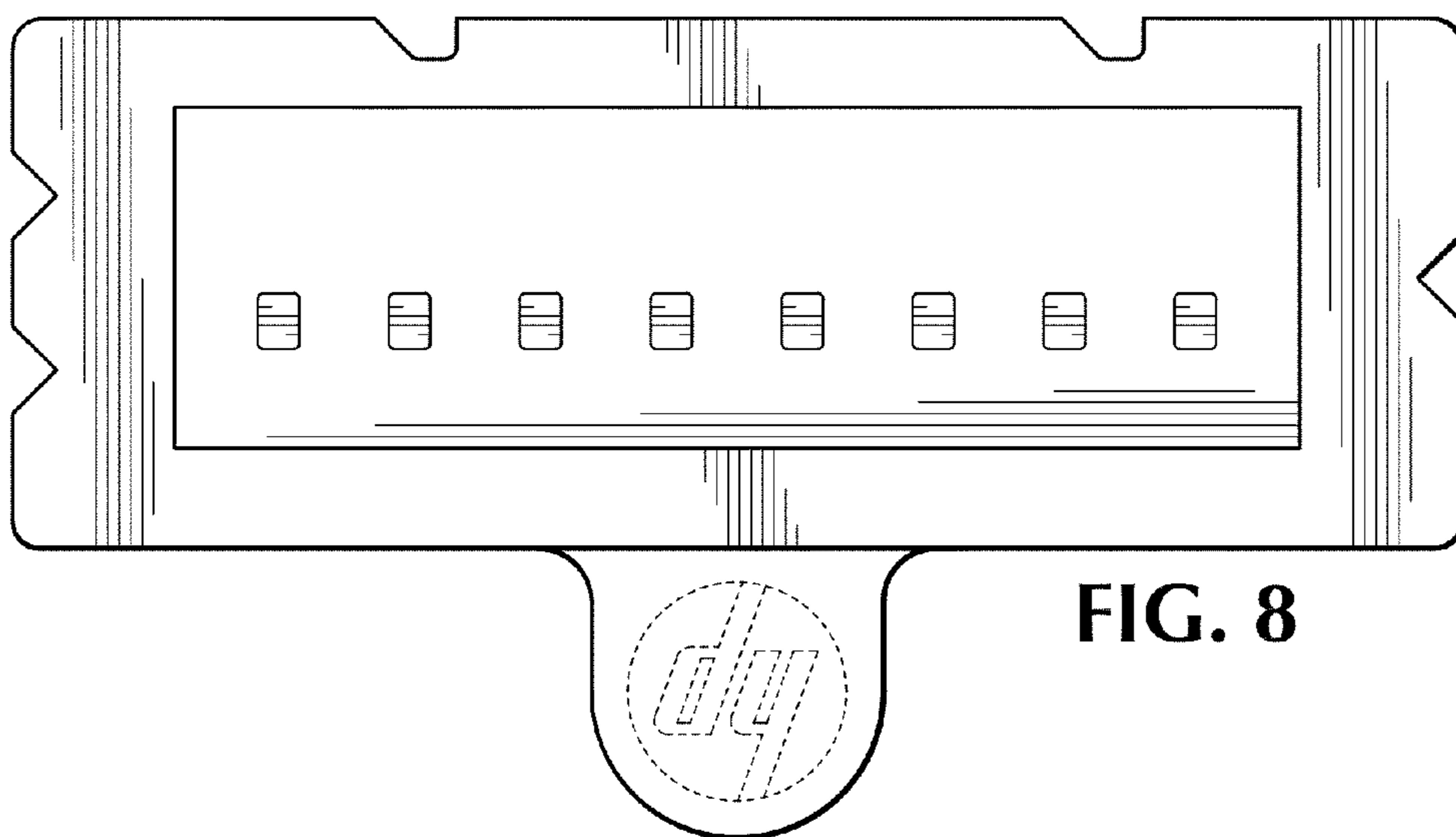


FIG. 8