



US00D655393S

(12) **United States Design Patent**
Whitaker

(10) **Patent No.:** **US D655,393 S**

(45) **Date of Patent:** **** Mar. 6, 2012**

(54) **MULTI-PORT VALVE**

(75) Inventor: **Carl T. Whitaker**, Berthoud, CO (US)

(73) Assignee: **Value Plastics, Inc.**, Fort Collins, CO (US)

(**) Term: **14 Years**

(21) Appl. No.: **29/339,063**

(22) Filed: **Jun. 23, 2009**

(51) **LOC (9) Cl.** **23-01**

(52) **U.S. Cl.** **D23/233**

(58) **Field of Classification Search** D23/233-237;
137/624.11, 624.16, 624.18, 624.2, 625.11,
137/625.12, 625.13, 625.15, 625.16, 625.41,
137/625.46, 625.47, 862, 870, 883, 625;
251/122, 205, 207, 327, 328, 903; 184/81;
D24/129

See application file for complete search history.

(56) **References Cited**

U.S. PATENT DOCUMENTS

163,261 A 5/1875 Ruppenthal
185,896 A 1/1877 Curtis

(Continued)

FOREIGN PATENT DOCUMENTS

BE 479098 1/1948

(Continued)

OTHER PUBLICATIONS

Brochure, "Precision Components", Value Plastics, Inc., 2002.

(Continued)

Primary Examiner — Joe A. Sincavage

Assistant Examiner — Maurice Stevens

(74) *Attorney, Agent, or Firm* — Dorsey & Whitney LLP

(57) **CLAIM**

The ornamental design for a multi-port valve, as shown and described.

DESCRIPTION

FIG. 1 is a front isometric view of a multi-port valve composed of a valve body and a directional.

FIG. 2 is a rear isometric view of the multi-port valve of FIG. 1.

FIG. 3 is a front elevation view of the multi-port valve of FIG. 1.

FIG. 4 is a rear elevation view of the multi-port valve of FIG. 1.

FIG. 5 is a right side elevation view of the multi-port valve of FIG. 1.

FIG. 6 is a left side elevation view of the multi-port valve of FIG. 1.

FIG. 7 is a top plan view of the multi-port valve of FIG. 1.

FIG. 8 is a bottom plan view of the multi-port valve of FIG. 1.

FIG. 9 is a front isometric view of the valve body of the multi-port valve of FIG. 1.

FIG. 10 is a rear isometric view of the valve body of FIG. 9.

FIG. 11 is a front elevation view of the valve body of FIG. 9.

FIG. 12 is a rear elevation view of the valve body of FIG. 9.

FIG. 13 is a right side elevation view of the valve body of FIG. 9.

FIG. 14 is a left side elevation view of the valve body of FIG. 9.

FIG. 15 is a top plan view of the valve body of FIG. 9; and,

FIG. 16 is a bottom plan view of the valve body of FIG. 9.

The broken line showing of unclaimed portions of the multi-port valve forms no part of the claimed design.

1 Claim, 12 Drawing Sheets

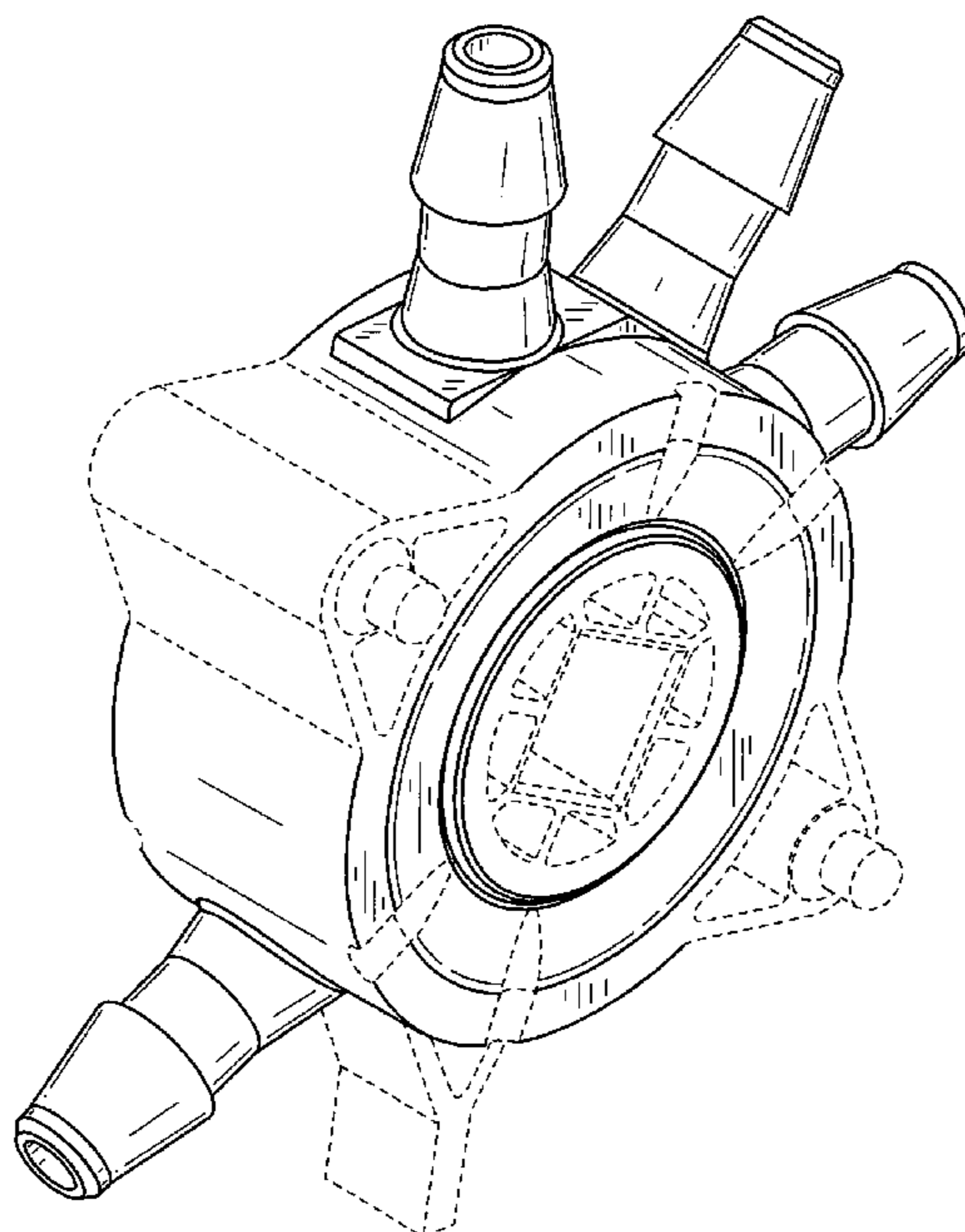

US D655,393 S

U.S. PATENT DOCUMENTS							
187,982	A	3/1877	Pirsson et al.	D196,473	S	10/1963	Hill
200,944	A	3/1878	Smith	3,124,157	A	3/1964	Krzewina
235,580	A	12/1880	Smith et al.	3,129,020	A	4/1964	Bujnowski
327,509	A	10/1885	Aldridge	3,171,196	A	3/1965	Helitas
584,008	A	6/1887	Munson	3,191,628	A *	6/1965	Kirkwood et al. 137/625.43
465,868	A	12/1891	List	3,217,400	A	11/1965	Illesy et al.
725,421	A	4/1903	Dinkins	3,217,771	A	11/1965	Beall et al.
727,982	A	5/1903	Ludwig	3,227,380	A	1/1966	Pinkston
874,957	A	12/1907	Godley	3,237,974	A	3/1966	Press
884,461	A	4/1908	Browne	3,245,703	A	4/1966	Manly
909,131	A	1/1909	Antic	3,276,799	A	10/1966	Moore et al.
951,889	A	3/1910	Teuer	3,279,497	A	10/1966	Norton et al.
D42,368	S	3/1912	Mossberg	3,314,696	A	4/1967	Ferguson et al.
1,029,819	A	6/1912	Nylander	3,317,214	A	5/1967	Durgom
1,033,187	A	7/1912	Metzger	D209,166	S	11/1967	Hunt
1,039,354	A	9/1912	Bonadio	D209,168	S	11/1967	Hunt
1,077,417	A	11/1913	McCracken	3,352,576	A	11/1967	Thomas
1,078,112	A	11/1913	Storm	3,382,892	A	5/1968	Cerbin
1,115,945	A	11/1914	Kunz	3,403,930	A	10/1968	Bernier
1,193,446	A	8/1916	Wells	3,432,176	A	3/1969	Valenziano
1,239,345	A	9/1917	Brown	3,448,760	A	6/1969	Cranage
1,255,847	A	2/1918	Arkin	3,450,424	A	6/1969	Calisher
1,259,684	A	3/1918	Vinten	3,512,808	A	5/1970	Graham
1,489,310	A	4/1924	Critchlow	3,523,701	A	8/1970	Graham
1,526,218	A	2/1925	Johnson	3,538,940	A	11/1970	Graham
1,578,504	A	3/1926	Bronson et al.	3,542,338	A	11/1970	Scaramucci
1,587,079	A	6/1926	Machino	3,545,490	A	12/1970	Burrus
1,767,073	A	6/1930	Ingold	3,550,626	A	12/1970	Daniels et al.
1,863,360	A	6/1932	Weatherhead	3,560,027	A	2/1971	Graham
1,950,947	A	3/1934	Mulroyan	3,563,265	A	2/1971	Graham
2,023,428	A	12/1935	Liebhardt	3,574,314	A	4/1971	Quercia
2,056,524	A	10/1936	Johnson	3,588,149	A	6/1971	Demler
2,066,473	A	1/1937	Jorgensen	3,596,933	A	8/1971	Luckenbill
2,097,628	A	11/1937	Liebhardt	3,599,843	A	8/1971	Johnston
2,099,335	A	11/1937	Hansen	3,600,917	A	8/1971	Krock
2,108,714	A	2/1938	Hirsch et al.	3,649,050	A	3/1972	Woodling
2,116,705	A	5/1938	Marx et al.	3,666,297	A	5/1972	Marks
2,139,745	A	12/1938	Goodall	3,690,336	A	9/1972	Drum
2,147,355	A	2/1939	Scholtes	3,712,583	A	1/1973	Martindale et al.
2,159,116	A	5/1939	Zacharias	3,747,964	A	7/1973	Nilsen
2,211,147	A	8/1940	Miller	3,750,238	A	8/1973	Tanner
2,257,321	A	9/1941	Arnold	3,815,887	A	6/1974	Curtis et al.
2,263,293	A	11/1941	Ewald	3,817,561	A	6/1974	Kay
2,264,815	A	12/1941	Thomsen	3,829,135	A	8/1974	Forni
2,340,119	A	1/1944	Graham	3,876,234	A	4/1975	Harms
2,346,445	A	4/1944	Merker et al.	3,889,710	A	6/1975	Brost
2,352,728	A	7/1944	Merker et al.	3,899,200	A	8/1975	Gamble
2,429,782	A	10/1947	Versoy	3,921,656	A	11/1975	Meisenheimer, Jr. et al.
2,432,946	A	12/1947	Theunissen	3,979,934	A	9/1976	Isenmann
2,470,800	A	5/1949	Ashton	3,990,674	A	11/1976	Schattenberg
2,479,499	A	8/1949	Le Clair	4,025,049	A	5/1977	Schmidt
2,500,720	A	3/1950	Van der Heem	4,039,213	A	8/1977	Walters
2,507,536	A	5/1950	Goodson	4,072,330	A	2/1978	Brysch
2,516,583	A	7/1950	Moore	4,099,748	A	7/1978	Kavick
2,535,740	A	12/1950	Knopp	4,113,627	A	9/1978	Leason
2,577,009	A	12/1951	Frantz	4,116,476	A	9/1978	Porter et al.
2,626,974	A	1/1953	Howard et al.	4,129,145	A	12/1978	Wynn
2,630,131	A	3/1953	Snyder	4,142,546	A	3/1979	Sandau
2,661,018	A	12/1953	Snyder	D252,470	S	7/1979	Pawlak
2,701,147	A	2/1955	Summerville	4,181,149	A	1/1980	Cox
2,722,399	A	11/1955	Oetiker	4,182,519	A	1/1980	Wilson
2,753,195	A	7/1956	Palmer	D254,505	S	3/1980	Parsons et al.
2,774,616	A	12/1956	Dodd et al.	4,200,605	A	4/1980	Imamura
2,790,571	A	4/1957	Flaith et al.	D255,145	S	5/1980	Nederman
2,864,628	A	12/1958	Edleson	4,220,360	A	9/1980	Jacek et al.
2,915,325	A	12/1959	Foster	D258,526	S	3/1981	Nederman
2,926,934	A	3/1960	Gill	4,253,687	A	3/1981	Maples
2,931,668	A	4/1960	Baley	D259,278	S	5/1981	McCaw et al.
2,937,892	A	5/1960	Prescott, Jr.	4,271,865	A	6/1981	Galloway et al.
2,948,553	A	8/1960	Gill et al.	4,282,175	A	8/1981	Volgstadt et al.
2,967,067	A	1/1961	Singer	4,287,644	A	9/1981	Durand
2,991,090	A	7/1961	De Cenzo	4,294,285	A *	10/1981	Joslyn 137/625.11
3,017,203	A	1/1962	Macleod	4,296,949	A	10/1981	Muetterties et al.
3,037,497	A	6/1962	Roberson	4,319,774	A	3/1982	Kavick
3,046,028	A	7/1962	Nathan	4,330,010	A	5/1982	Drescher et al.
3,048,415	A	8/1962	Shook	4,330,142	A	5/1982	Paini
3,073,342	A	1/1963	Magorien	4,331,175	A	5/1982	Brake et al.
3,078,068	A	2/1963	Romney	4,331,177	A	5/1982	Makishima
				4,340,200	A	7/1982	Stegmeier

US D655,393 S

4,345,786 A	8/1982	Egert	5,074,601 A	12/1991	Spors et al.
4,346,703 A	8/1982	Dennehey	5,076,615 A	12/1991	Sampson
4,351,351 A	9/1982	Flory et al.	5,078,429 A	1/1992	Braut et al.
4,366,816 A	1/1983	Bayard et al.	5,085,472 A	2/1992	Guest
4,393,548 A	7/1983	Herb	5,090,448 A	2/1992	Truchet
4,397,442 A	8/1983	Larkin	5,090,747 A	2/1992	Kotake
4,407,526 A	10/1983	Cicenas	5,094,482 A	3/1992	Petty et al.
4,431,031 A	2/1984	Ettlenger	5,104,158 A	4/1992	Meyer et al.
4,431,218 A	2/1984	Paul	5,106,127 A	4/1992	Briet
4,434,121 A	2/1984	Schaper	D326,155 S	5/1992	Boehringer et al.
4,436,125 A	3/1984	Blenkush	5,110,163 A	5/1992	Benson et al.
4,437,689 A	3/1984	Goebel et al.	5,112,084 A	5/1992	Washizu
4,439,188 A	3/1984	Dennehey	5,114,250 A	5/1992	Usui
4,458,719 A	7/1984	Strybel	D326,715 S	6/1992	Schmidt
4,489,914 A	12/1984	Stevenson et al.	5,123,677 A	6/1992	Kreczko et al.
4,489,961 A	12/1984	Laidig	5,143,381 A	9/1992	Temple
4,500,118 A	2/1985	Blenkush	5,160,177 A	11/1992	Washizu
4,527,745 A	7/1985	Butterfield et al.	5,160,474 A	11/1992	Huff
4,541,457 A	9/1985	Blenkush	5,165,733 A	11/1992	Sampson
4,541,657 A	9/1985	Smyth	5,169,161 A	12/1992	Jones
4,553,587 A	11/1985	Traylor	D332,482 S	1/1993	Petty et al.
D282,962 S	3/1986	Gerber	5,176,406 A	1/1993	Straghan
4,580,816 A	4/1986	Campbell et al.	5,181,752 A	1/1993	Benson et al.
4,603,888 A	8/1986	Goodall et al.	D333,178 S	2/1993	Novy
4,603,890 A	8/1986	Huppee	5,190,224 A	3/1993	Hamilton
4,613,112 A	9/1986	Philipot et al.	5,222,279 A	6/1993	Frano et al.
4,616,859 A	10/1986	Brunet	5,228,724 A	7/1993	Godeau
4,626,001 A	12/1986	Lee	5,232,020 A	8/1993	Mason et al.
4,632,436 A	12/1986	Kimura	D339,417 S	9/1993	Sampson et al.
4,635,972 A	1/1987	Lyll	5,251,025 A	10/1993	Cooper et al.
4,645,245 A	2/1987	Cunningham	5,273,053 A	12/1993	Pohndorf
4,658,326 A	4/1987	Clark et al.	5,297,826 A	3/1994	Percebois et al.
4,659,116 A	4/1987	Cameron	5,316,041 A	5/1994	Ramacier, Jr. et al.
4,694,544 A	9/1987	Chapman	5,318,332 A	6/1994	Hohmann et al.
4,699,298 A	10/1987	Grant et al.	5,330,235 A	7/1994	Wagner et al.
4,700,926 A	10/1987	Hansen	5,348,051 A	9/1994	Kallenbach
4,703,957 A	11/1987	Blenkush	5,348,354 A	9/1994	Badoureaux
4,706,847 A	11/1987	Sankey et al.	5,356,183 A	10/1994	Cole
4,712,280 A	12/1987	Fildan	5,374,088 A	12/1994	Moretti et al.
4,733,890 A	3/1988	Vyse	5,385,311 A	1/1995	Morikawa et al.
4,738,401 A	4/1988	Filicicchia	5,385,331 A	1/1995	Allread et al.
4,753,268 A	6/1988	Palau	D357,307 S	4/1995	Ramacier, Jr. et al.
4,768,558 A *	9/1988	Weber 137/862	5,405,333 A	4/1995	Richmond
4,776,067 A	10/1988	Sorensen	5,405,339 A	4/1995	Kohnen et al.
4,790,567 A	12/1988	Kawano et al.	5,405,340 A	4/1995	Fageol et al.
4,790,569 A	12/1988	Chaffee	5,411,300 A	5/1995	Mitsui
4,792,115 A	12/1988	Jindra et al.	5,417,442 A	5/1995	Jornhagen
4,793,637 A	12/1988	Laipply et al.	5,421,622 A	6/1995	Godeau
D300,361 S	3/1989	Tokarz	5,437,650 A	8/1995	Larkin et al.
4,824,148 A	4/1989	Grabowski	5,462,313 A	10/1995	Rea et al.
4,827,921 A	5/1989	Rugheimer	5,494,074 A	2/1996	Ramacier, Jr. et al.
4,832,237 A	5/1989	Hurford, Jr.	D369,409 S	4/1996	Salter
4,834,423 A	5/1989	DeLand	5,507,733 A	4/1996	Larkin et al.
4,844,512 A	7/1989	Gahwiler	5,511,527 A	4/1996	Lorraine et al.
4,863,201 A	9/1989	Carstens	D372,093 S	7/1996	Sampson et al.
4,863,202 A	9/1989	Oldford	5,536,258 A	7/1996	Folden
4,896,402 A	1/1990	Jansen et al.	5,542,712 A	8/1996	Klinger et al.
4,900,065 A	2/1990	Houck	5,547,166 A	8/1996	Engdahl
4,903,995 A	2/1990	Blenkush et al.	5,547,230 A	8/1996	Bank et al.
4,923,228 A	5/1990	Laipply	5,553,895 A	9/1996	Karl et al.
4,928,999 A	5/1990	Landriault et al.	D375,160 S	10/1996	Sampson et al.
4,934,655 A	6/1990	Blenkush et al.	5,568,946 A	10/1996	Jackowski
4,935,992 A	6/1990	Due	5,595,217 A	1/1997	Gillen et al.
4,946,204 A	8/1990	Boticki	5,601,317 A	2/1997	Crouse et al.
4,949,745 A	8/1990	McKeon	5,607,190 A	3/1997	Exandier et al.
4,966,398 A	10/1990	Peterson	5,617,609 A	4/1997	Bently
4,969,879 A	11/1990	Lichte	5,620,025 A *	4/1997	Lewin 137/625.15
D313,067 S	12/1990	Kotake et al.	5,628,726 A	5/1997	Cotter
D313,277 S	12/1990	Haining	D380,262 S	6/1997	Van Funderburk et al.
D314,050 S	1/1991	Sone	D382,639 S	8/1997	Musgrave et al.
D314,233 S	1/1991	Medvick	5,681,062 A	10/1997	Fukao et al.
4,982,736 A	1/1991	Schneider	5,682,662 A	11/1997	Coules et al.
4,991,880 A	2/1991	Bernart	5,683,117 A	11/1997	Corbett et al.
5,009,252 A	4/1991	Faughn	D387,147 S	12/1997	Vandermast et al.
5,015,014 A	5/1991	Sweeney	5,695,223 A	12/1997	Boticki
5,029,908 A	7/1991	Belisaire	D388,876 S	1/1998	Sampson
5,033,777 A	7/1991	Blenkush	5,709,244 A	1/1998	Patriquin et al.
D319,312 S	8/1991	Schneider	5,725,258 A	3/1998	Kujawski
5,052,725 A	10/1991	Meyer et al.	5,737,810 A	4/1998	Krauss

US D655,393 S

Page 4

5,745,957 A	5/1998	Khokhar et al.	6,454,314 B1	9/2002	Grosspietsch et al.
5,746,414 A	5/1998	Weldon et al.	6,481,758 B1	11/2002	Andre et al.
5,762,646 A	6/1998	Cotter	6,481,759 B1	11/2002	Kawasaki et al.
5,784,750 A	7/1998	Sankovic et al.	6,485,064 B1	11/2002	Davidson
5,799,987 A	9/1998	Sampson	6,485,483 B1	11/2002	Fujii
5,820,614 A	10/1998	Erskine et al.	6,505,866 B1	1/2003	Nakamura et al.
5,837,180 A	11/1998	Linder et al.	6,508,807 B1	1/2003	Peters
5,845,943 A	12/1998	Ramacier, Jr. et al.	6,520,546 B2	2/2003	Szabo
5,855,568 A	1/1999	Battiato et al.	D471,261 S	3/2003	Kozu
5,879,033 A	3/1999	Hansel et al.	6,540,263 B1	4/2003	Sausner
5,882,047 A	3/1999	Ostrander et al.	6,543,745 B1	4/2003	Enerson
5,884,531 A	3/1999	Koenig	6,595,964 B2	7/2003	Finley et al.
D407,803 S	4/1999	Redman	6,609,696 B2	8/2003	Enerson
5,897,142 A	4/1999	Kulevsky	6,612,634 B1	9/2003	Zoppas
5,911,367 A	6/1999	McInerney	6,626,465 B2	9/2003	Lacroix et al.
5,911,403 A	6/1999	deCler et al.	D481,125 S	10/2003	Hayamizu
5,911,404 A	6/1999	Cheng	6,641,177 B1	11/2003	Pinciario
5,930,424 A	7/1999	Heimberger et al.	6,649,829 B2	11/2003	Garber et al.
5,937,501 A	8/1999	Imgram	6,652,007 B1	11/2003	Hwang
5,938,244 A	8/1999	Meyer	D484,241 S	12/2003	Peters et al.
5,941,577 A	8/1999	Musellec	6,669,681 B2	12/2003	Jepson et al.
5,942,730 A	8/1999	Schwarz et al.	6,676,172 B2	1/2004	Alksnis
D413,967 S	9/1999	Yuen	D486,909 S	2/2004	Cise et al.
5,957,898 A	9/1999	Jepson et al.	6,688,654 B2	2/2004	Romero
5,961,157 A	10/1999	Baron et al.	6,692,038 B2	2/2004	Braun
5,964,485 A	10/1999	Hame et al.	6,695,817 B1	2/2004	Fangrow
5,965,077 A	10/1999	Rowley et al.	6,722,705 B2	4/2004	Korkor
5,975,489 A	11/1999	deCler et al.	6,722,708 B2	4/2004	Morohoshi et al.
5,984,378 A	11/1999	Ostrander et al.	6,762,365 B2	7/2004	Inoue et al.
5,988,704 A	11/1999	Ryhman	6,767,017 B2	7/2004	Crapart et al.
6,012,743 A	1/2000	Godeau et al.	D495,050 S	8/2004	Guala
6,015,171 A	1/2000	Schorn	6,783,520 B1	8/2004	Candray et al.
D419,861 S	2/2000	Khokhar	D497,428 S	10/2004	Hayamizu
6,019,348 A	2/2000	Powell	6,799,747 B1	10/2004	Lai
6,024,124 A	2/2000	Braun et al.	D498,533 S	11/2004	Hayamizu
6,029,701 A	2/2000	Chaffardon et al.	6,814,726 B1	11/2004	Lauer
6,032,691 A	3/2000	Powell et al.	6,840,277 B1	1/2005	Nimberger
6,041,805 A	3/2000	Gydesen et al.	6,846,021 B2	1/2005	Rohde et al.
D422,487 S	4/2000	Khokhar	6,848,723 B2	2/2005	Lamich
6,050,297 A	4/2000	Ostrowski et al.	6,863,314 B2	3/2005	Guest
6,076,234 A	6/2000	Khokhar et al.	6,871,878 B2	3/2005	Miros
6,077,245 A	6/2000	Heinrich et al.	D503,778 S	4/2005	Wicks
6,077,259 A	6/2000	Caizza et al.	6,886,803 B2	5/2005	Mikiya et al.
6,082,401 A	7/2000	Braun et al.	6,897,374 B2	5/2005	Garber et al.
6,086,044 A	7/2000	Guest	6,899,315 B2	5/2005	Maiville et al.
6,089,540 A	7/2000	Heinrichs et al.	D507,647 S	7/2005	Beck et al.
6,099,045 A	8/2000	Pirona	6,916,007 B2	7/2005	deCler et al.
6,112,855 A	9/2000	Camacho et al.	6,916,050 B2	7/2005	Milhas
6,123,690 A	9/2000	Mejslov	6,926,311 B2	8/2005	Chang et al.
6,135,150 A	10/2000	Powell et al.	6,929,246 B2	8/2005	Arzenton et al.
6,135,992 A	10/2000	Wang	6,945,273 B2	9/2005	Reid
6,142,538 A	11/2000	Volgstadt et al.	6,949,084 B2	9/2005	Marggi et al.
6,145,896 A	11/2000	Vitel et al.	6,981,547 B2	1/2006	Maguire et al.
6,152,914 A	11/2000	Van De Kerkhof et al.	6,997,486 B2	2/2006	Milhas
6,155,610 A	12/2000	Hutchinson	6,997,919 B2	2/2006	Olsen et al.
6,161,578 A	12/2000	Braun et al.	7,005,581 B2	2/2006	Burnette
6,176,523 B1	1/2001	Winslett	7,011,342 B2	3/2006	Guivarc'h et al.
6,182,694 B1	2/2001	Sievers et al.	7,014,214 B2	3/2006	Kaneko
6,189,560 B1	2/2001	Reynolds	D522,109 S	5/2006	White et al.
6,199,915 B1	3/2001	Becker	7,040,670 B2	5/2006	Madden
6,199,919 B1	3/2001	Kawasaki et al.	7,044,161 B2	5/2006	Tiberghien
6,199,920 B1	3/2001	Neustadtl	7,044,506 B2	5/2006	Dong
6,221,064 B1	4/2001	Nadal	D523,553 S	6/2006	Beck et al.
6,231,089 B1	5/2001	DeCler et al.	7,081,223 B2	7/2006	Khoury
D444,054 S	6/2001	Bernard et al.	7,108,297 B2	9/2006	Takayanagi et al.
6,250,688 B1	6/2001	Kirby	7,118,138 B1	10/2006	Rowley et al.
6,257,626 B1	7/2001	Campau	7,128,348 B2	10/2006	Kawamura et al.
6,260,851 B1	7/2001	Baron	7,137,654 B2	11/2006	Segal et al.
6,261,282 B1	7/2001	Jepson et al.	7,140,592 B2	11/2006	Phillips
6,293,596 B1	9/2001	Kinder	7,147,252 B2	12/2006	Teuscher et al.
6,296,796 B1	10/2001	Gordon	7,150,478 B2	12/2006	Poirier et al.
6,302,147 B1	10/2001	Rose et al.	7,153,296 B2	12/2006	Mitchell
6,318,764 B1	11/2001	Trede et al.	D540,944 S	4/2007	Guala
6,344,033 B1	2/2002	Jepson et al.	7,210,917 B2	5/2007	Lai et al.
D459,206 S	6/2002	Caveney et al.	D547,446 S	7/2007	Racz et al.
6,402,207 B1	6/2002	Segal et al.	D550,355 S	9/2007	Racz et al.
6,422,574 B1	7/2002	Mooklar	D557,409 S	12/2007	Veliss et al.
6,423,053 B1	7/2002	Lee	7,316,428 B2	1/2008	Takayanagi et al.
6,439,620 B1	8/2002	Guest	D564,660 S	3/2008	Hayashi

7,343,931	B2	3/2008	Packham	2008/0007051	A1	1/2008	Jensen et al.
D567,340	S	4/2008	Tiberghien	2008/0011703	A1	1/2008	Schmeisser et al.
D569,507	S	5/2008	Blanchard	2008/0012314	A1	1/2008	Harger et al.
D569,955	S	5/2008	Chen	2008/0018105	A1	1/2008	Le Bars
7,377,553	B2	5/2008	Takayanagi	2008/0048448	A1	2/2008	Jamison et al.
D570,457	S	6/2008	Brown	2008/0078464	A1	4/2008	Loewe
7,390,029	B2	6/2008	Matsubara	2008/0111371	A1	5/2008	Feger et al.
7,434,842	B2	10/2008	Schmidt	2008/0111372	A1	5/2008	Trede et al.
7,434,846	B2	10/2008	Baumgartner	2008/0129047	A1	6/2008	Blivet et al.
7,448,653	B2	11/2008	Jensen et al.	2008/0164694	A1	7/2008	Zdroik et al.
7,464,970	B2	12/2008	Yamada et al.	2008/0191466	A1	8/2008	Knipple et al.
7,467,813	B2	12/2008	Gunderson	2008/0200901	A1	8/2008	Rasmussen et al.
7,469,472	B2	12/2008	DeCler et al.	2008/0277923	A1	11/2008	Brandt et al.
7,478,840	B2	1/2009	Yousseffifar	2008/0277924	A1	11/2008	Jensen et al.
7,494,156	B2	2/2009	Okada	2008/0284167	A1	11/2008	Lim et al.
7,503,595	B2	3/2009	McKay	2008/0287920	A1	11/2008	Scott
7,516,990	B2	4/2009	Jamison et al.	2009/0079187	A1	3/2009	Malone
7,547,047	B2	6/2009	deCler et al.	2009/0127847	A1	5/2009	Hagen et al.
D595,845	S	7/2009	Miros et al.	2009/0129047	A1	5/2009	Park et al.
D595,846	S	7/2009	Racz et al.	2009/0140519	A1	6/2009	Pavnaskar et al.
D596,288	S	7/2009	Racz et al.	2009/0167018	A1	7/2009	Lien
D596,739	S	7/2009	Ng et al.	2009/0187166	A1	7/2009	Young
7,562,906	B2	7/2009	Schmidt	2009/0188575	A1	7/2009	Williams et al.
7,566,077	B2	7/2009	Tsurumi	2009/0256355	A1	10/2009	Wicks et al.
7,581,763	B2	9/2009	Salomon-Bahls	2010/0001516	A1	1/2010	Pisula, Jr. et al.
7,614,666	B2	11/2009	Eggert et al.	2010/0056975	A1	3/2010	Dale et al.
7,647,954	B2	1/2010	Garber et al.	2010/0078934	A1	4/2010	Matsunaga
7,666,178	B2	2/2010	McMichael	2010/0185040	A1	7/2010	Uber, III et al.
D612,021	S	3/2010	Schmidt	2010/0194100	A1	8/2010	Koch
7,677,608	B2	3/2010	Takayanagi	2010/0276922	A1	11/2010	Rehder et al.
D613,853	S	4/2010	Ng et al.	2010/0295295	A1	11/2010	Schmidt
7,695,020	B2	4/2010	Schmidt	2010/0301599	A1	12/2010	Jensen et al.
7,731,244	B2	6/2010	Miros et al.	2010/0319796	A1*	12/2010	Whitaker 137/625.46
D619,706	S	7/2010	Schon et al.	2011/0012340	A1	1/2011	Packham et al.
D629,894	S	12/2010	Lombardi, III et al.	2011/0127767	A1	6/2011	Wicks et al.
7,849,877	B2*	12/2010	Tan et al. 137/625.46	2011/0204621	A1	8/2011	Whitaker et al.
D630,320	S	1/2011	Lombardi, III et al.	2011/0204622	A1	8/2011	Lewis et al.
D632,783	S	2/2011	Maesarapu	2011/0210541	A1	9/2011	Lewis et al.
D634,840	S	3/2011	Wicks et al.				
7,976,071	B2	7/2011	Bibby				
D645,547	S	9/2011	Lombardi, III et al.				
2001/0017466	A1	8/2001	Braun	DE	1868896	3/1963	
2002/0022762	A1	2/2002	Beane et al.	DE	3439522	8/1985	
2002/0093192	A1	7/2002	Matkovich	DE	3533000	3/1987	
2002/0140172	A1	10/2002	Platusich	DE	4122455	1/1993	
2002/0156344	A1	10/2002	Pasricha et al.	DE	19800050	7/1998	
2002/0185861	A1	12/2002	Inoue	DE	102005015343	10/2006	
2003/0004397	A1	1/2003	Kameya et al.	EP	0360634	3/1990	
2003/0067162	A1	4/2003	Welsh et al.	EP	0390746	10/1990	
2003/0193188	A1	10/2003	Miros	EP	0267067	7/1991	
2003/0230894	A1	12/2003	Cleveland et al.	EP	0482277	4/1992	
2004/0021318	A1	2/2004	Fritze et al.	EP	0592823	4/1994	
2004/0056484	A1	3/2004	Kwon et al.	EP	0715111	6/1996	
2004/0094903	A1	5/2004	Sutherland	EP	0865779	9/1998	
2004/0195830	A1	10/2004	Gilmour	EP	0877891	11/1998	
2004/0199143	A1	10/2004	Lauer	EP	0890054	1/1999	
2004/0227346	A1	11/2004	Jamison et al.	EP	0982525	3/2000	
2004/0232696	A1	11/2004	Andre	EP	1497582	1/2005	
2005/0033237	A1	2/2005	Fentress et al.	EP	1564469	8/2005	
2005/0046184	A1	3/2005	Chang	EP	1843074	10/2007	
2005/0057042	A1	3/2005	Wicks	FR	2031965	11/1970	
2005/0082828	A1	4/2005	Wicks et al.	FR	2429370	1/1980	
2005/0087981	A1	4/2005	Yamada et al.	FR	280871	10/2001	
2005/0209583	A1	9/2005	Powers et al.	FR	2853043	10/2004	
2005/0217265	A1	10/2005	Popp et al.	FR	2870921	12/2005	
2005/0242579	A1	11/2005	Bright et al.	FR	2903164	1/2008	
2005/0275220	A1	12/2005	Shu	GB	583459	12/1946	
2006/0066100	A1	3/2006	Nakashima et al.	GB	890775	3/1962	
2006/0152003	A1	7/2006	Slunick et al.	GB	2177769	1/1987	
2006/0264814	A1	11/2006	Sage	GB	2218166	11/1989	
2006/0293629	A1	12/2006	Cote, Sr. et al.	GB	2271157	4/1994	
2007/0025811	A1	2/2007	Wilhelm	GB	2379253	3/2003	
2007/0029795	A1	2/2007	Moner et al.	JP	53-006918	1/1978	
2007/0029796	A1	2/2007	Bibby	JP	5-223189	8/1993	
2007/0106213	A1	5/2007	Spera et al.	JP	7-145889	6/1995	
2007/0137718	A1	6/2007	Rushlander et al.	JP	10-169869	6/1998	
2007/0169825	A1	7/2007	Packham et al.	JP	11-82849	3/1999	
2007/0209716	A1	9/2007	Rankin	JP	2003-42363	2/2003	
2007/0284875	A1	12/2007	Salomon-Bahls et al.	JP	2003-42368	2/2003	
				WO	WO 93/17270	9/1993	
FOREIGN PATENT DOCUMENTS							

WO	WO 95/08732	3/1995
WO	WO 00/79172	12/2000
WO	WO 2004/104466	12/2004
WO	WO 2005/064216	7/2005
WO	WO 2006/031958	3/2006
WO	WO 2006/073778	7/2006
WO	WO 2006/084171	8/2006
WO	WO 2006/135666	12/2006
WO	WO 2007/038222	4/2007
WO	WO 2007/116387	10/2007
WO	WO 2007/120620	10/2007
WO	WO 2008/023021	2/2008
WO	WO 2009/026441	2/2009

OTHER PUBLICATIONS

About Us [online], Thuro Metal Products [retrieved on Apr. 9, 2010], retrieved from the Internet: <URL: <http://www.thurometal.com/about.html>>, 2 pages.

Barbed Tee Adapter, 1/2 in to 2/8 in to 1/2 in [Item # F1728], http://www.horticulturesource.com/product_info.php/products_id/4016/language/en; dated accessed Sep. 14, 2009, 3 pages.

Capabilities [online], Jay Manufacturing Corp., retrieved on Apr. 9, 2010, retrieved from the Internet: <URL: <http://www.jaymfg.com/capabilities.htm>>, 2 pages.

Flojet "Quick Connect" Port System Adapter 90 Elbow Type Quad Port X 1/2 Hose Barb, http://www.amazon.com/Quick-Connect-Port-System-Quad-Barb-90/dp/B0000AZ771/ref=sr_1_16?s=sporting-goods&ie=UTF8&qid=1300220596&sr=1-16, date accessed Sep. 14, 2009; 3 pages.

High-Flow Quick Disconnect Couplings; http://www.coleparmer.com/catalog/product_view.asp?sku=3130355; date accessed Sep. 14, 2009, 2 pages.

Mills, The Process of Vacuum-forming Plastic Parts, IPFrontline.com [online], retrieved on Apr. 9, 2010, retrieved from the Internet: <URL: <http://www.ipfrontline.com/depts/article.asp?id=453&deptid=2>>, 3 pages.

Nylon, Polypropylene Kynar (PVDF) Plastic Fittings for Flexible Tubing & Hose, http://www.omega.com/pdf/tubing/fittings_tubing_hose/nylon_poly_kynar/nylon.asp; dated accessed Sep. 14, 2009, 2 pages.

Science of Hose Barbs, Colder Products Company, <http://www.pddnet.com/article-the-science-of-hose-barbs/>, date accessed Sep. 4, 2009, 6 pages.

Stackable Hose Barb Elbow - 1/2 CTS x 1/2 ID Barb, http://www.freshwatersystems.com/p-1714-stackable-hose-barb-elbow-12-cts-x-12-idbarb.aspx?affiliated=10052&utm_source=shopzilla

&utm_medium=Feed&utm_campaign=Product&utm_term=3512-1008, date accessed Sep. 14, 2009, 1 page.

Stainless Steel Overview: History [online], Stainless Steel Industry of North America, retrieved on Apr. 9, 2010, retrieved from the Internet: <URL: <http://www.ssina.com/overview/history.html>>, 1 page.

U.S. Appl. No. 12/818,973, filed Dec. 23, 2010, by Williams et al., pending, copy attached.

About Us [online], Thuro Metal Products [retrieved on Apr. 9, 2010], retrieved from the Internet: URL: <http://www.thurometal.com/about.html>>, 2 pages.

Barbed Tee Adapter, 1/2 in to 2/8 in to 1/2 in [Item # F1728], http://www.horticulturesource.com/product_info.php/products_id/4016/language/en; dated accessed Sep. 14, 2009, 3 pages.

Capabilities [online], Jay Manufacturing Corp., retrieved on Apr. 9, 2010, retrieved from the Internet: <URL: <http://www.jaymfg.com/capabilities.htm>>, 2 pages.

Flojet "Quick Connect" Port System Adapter 90 Elbow Type Quad Port X 1/2 Hose Barb, http://www.amazon.com/Quick-Connect-Port-System-Quad-Barb-90/dp/B0000AZ771/ref=sr_1_16?s=sporting-goods&ie=UTF8&qid=1300220596&sr=1-16, date accessed Sep. 14, 2009; 3 pages.

High-Flow Quick Disconnect Couplings; http://www.coleparmer.com/catalog/product_view.asp?sku=3130355; date accessed Sep. 14, 2009, 3 pages.

Mills, The Process of Vacuum-forming Plastic Parts, IPFrontline.com [online], retrieved on Apr. 9, 2010, retrieved from the Internet: <URL: <http://www.ipfrontline.com/depts/article.asp?id=453&deptid=2>>, 3 pages.

Nylon, Polypropylene Kynar (PVDF) Plastic Fittings for Flexible Tubing & Hose, http://www.omega.com/pdf/tubing/fittings_tubing_hose/nylon_poly_kynar/nylon.asp; dated accessed Sep. 14, 2009, 2 pages.

Science of Hose Barbs, Colder Products Company, <http://www.pddnet.com/article-the-science-of-hose-barbs/>, date accessed Sep. 4, 2009, 6 pages.

Stackable Hose Barb Elbow—1/2 CTS x 1/2 ID Barb, http://www.freshwatersystems.com/p-1714-stackable-hose-barb-elbow-12-cts-x-12-id-barb.aspx?affiliated=10052&utm_source=shopzilla&utm_medium=Feed&utm_campaign=Product&utm_term=3512-1008, date accessed Sep. 14, 2009, 1 page.

Stainless Steel Overview: History [online], Stainless Steel Industry of North America, retrieved on Apr. 9, 2010, retrieved from the Internet: <URL: <http://www.ssina.com/overview/history.html>>, 1 page.

* cited by examiner

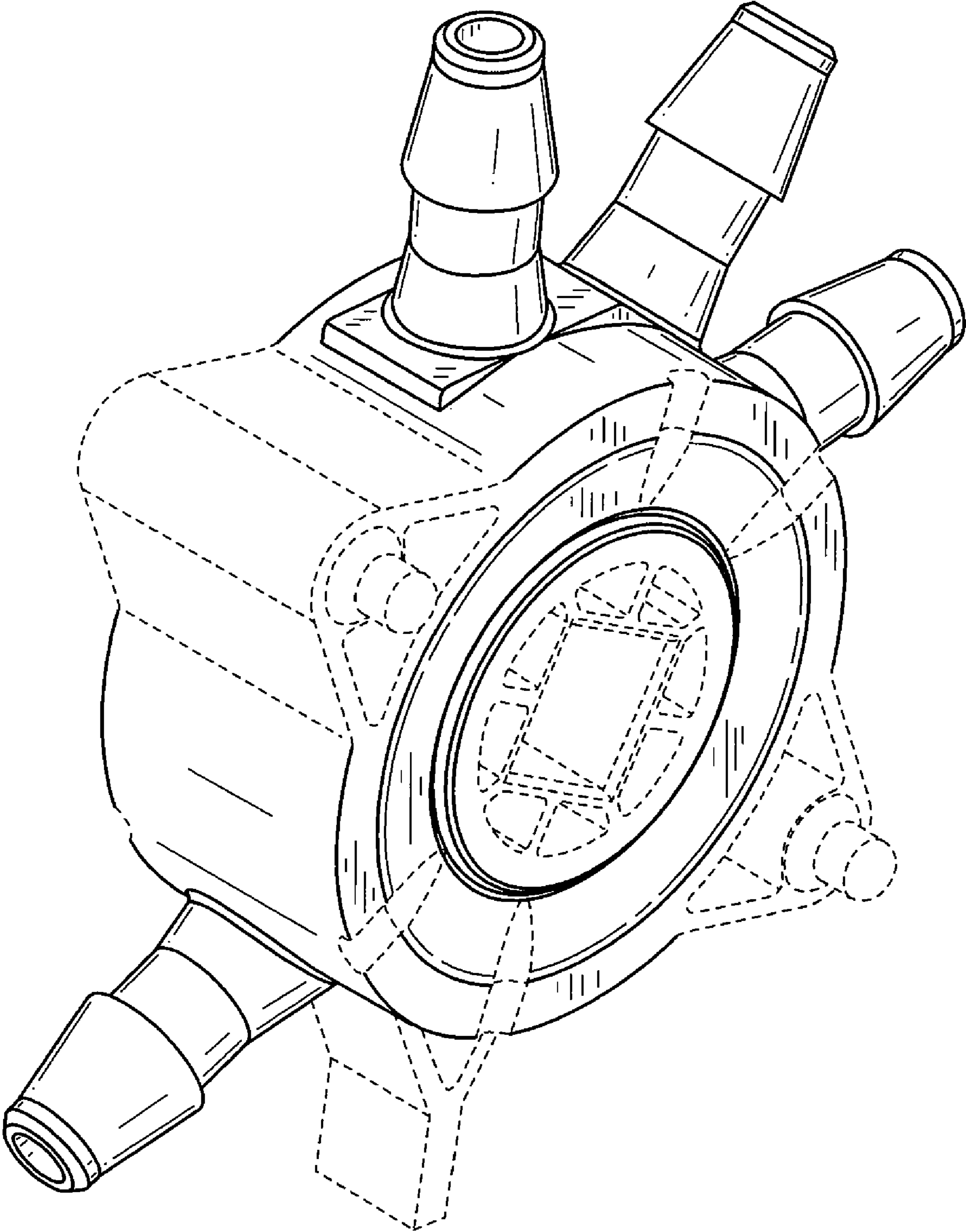

FIG.1

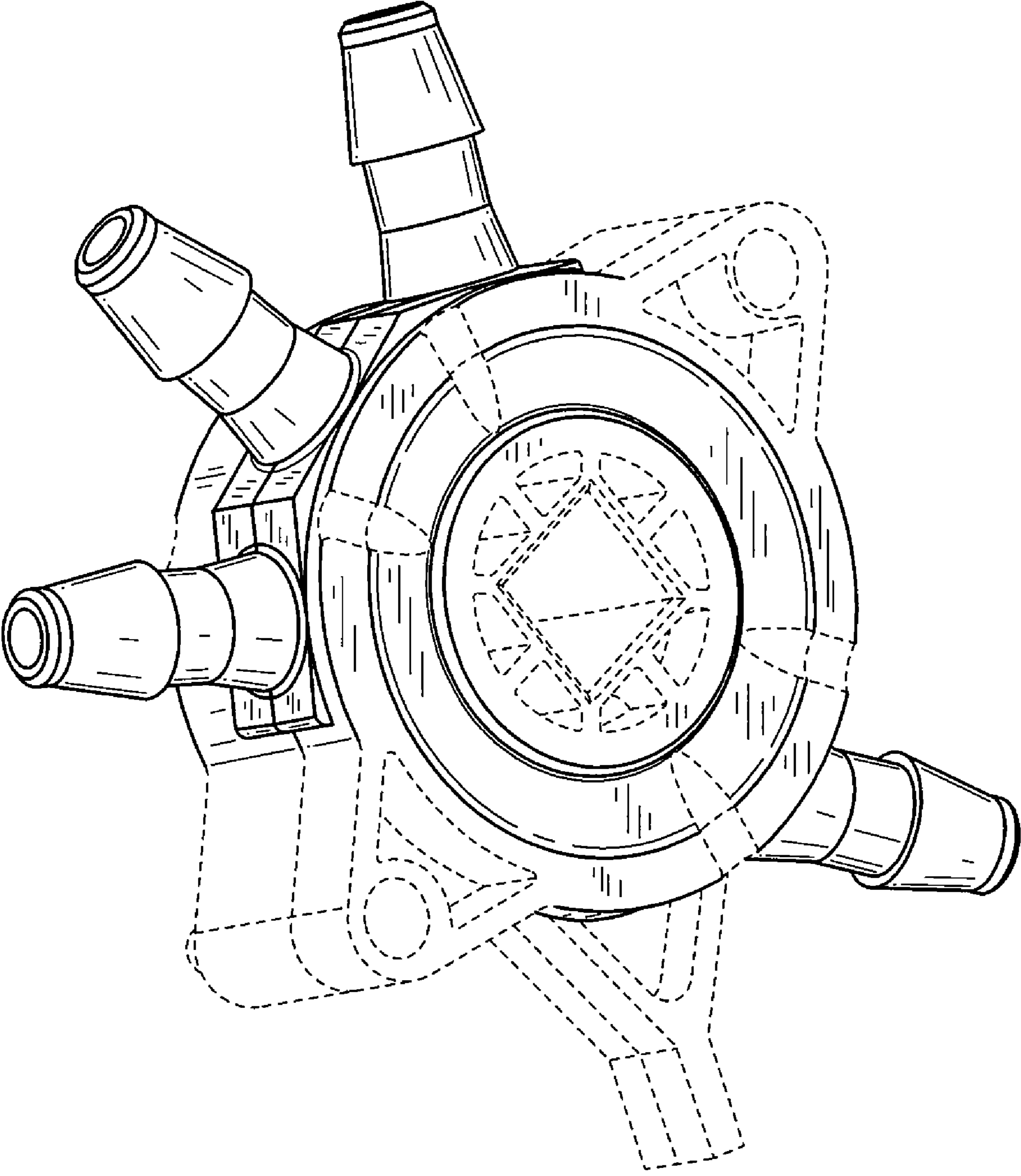

FIG.2

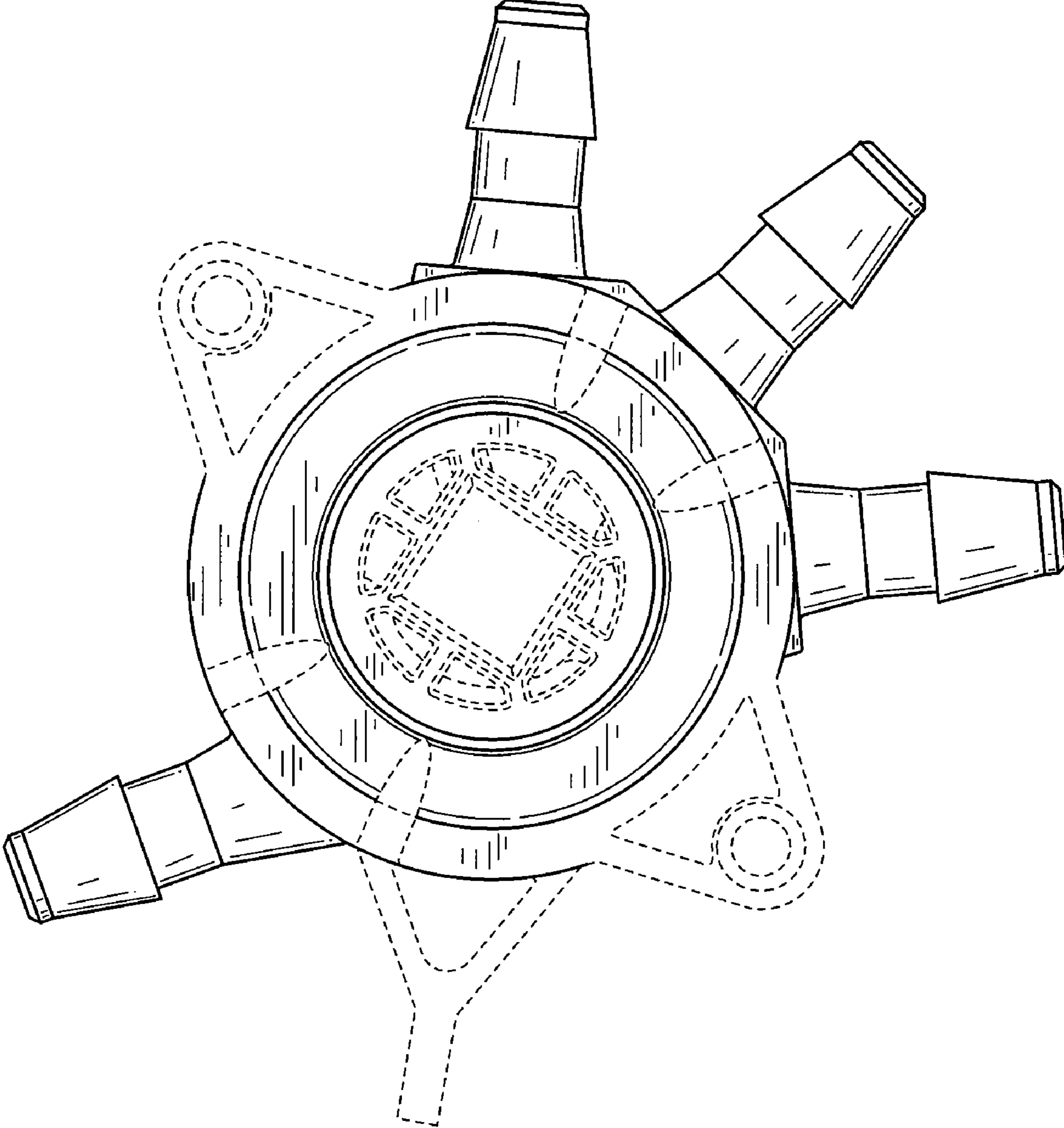

FIG.3

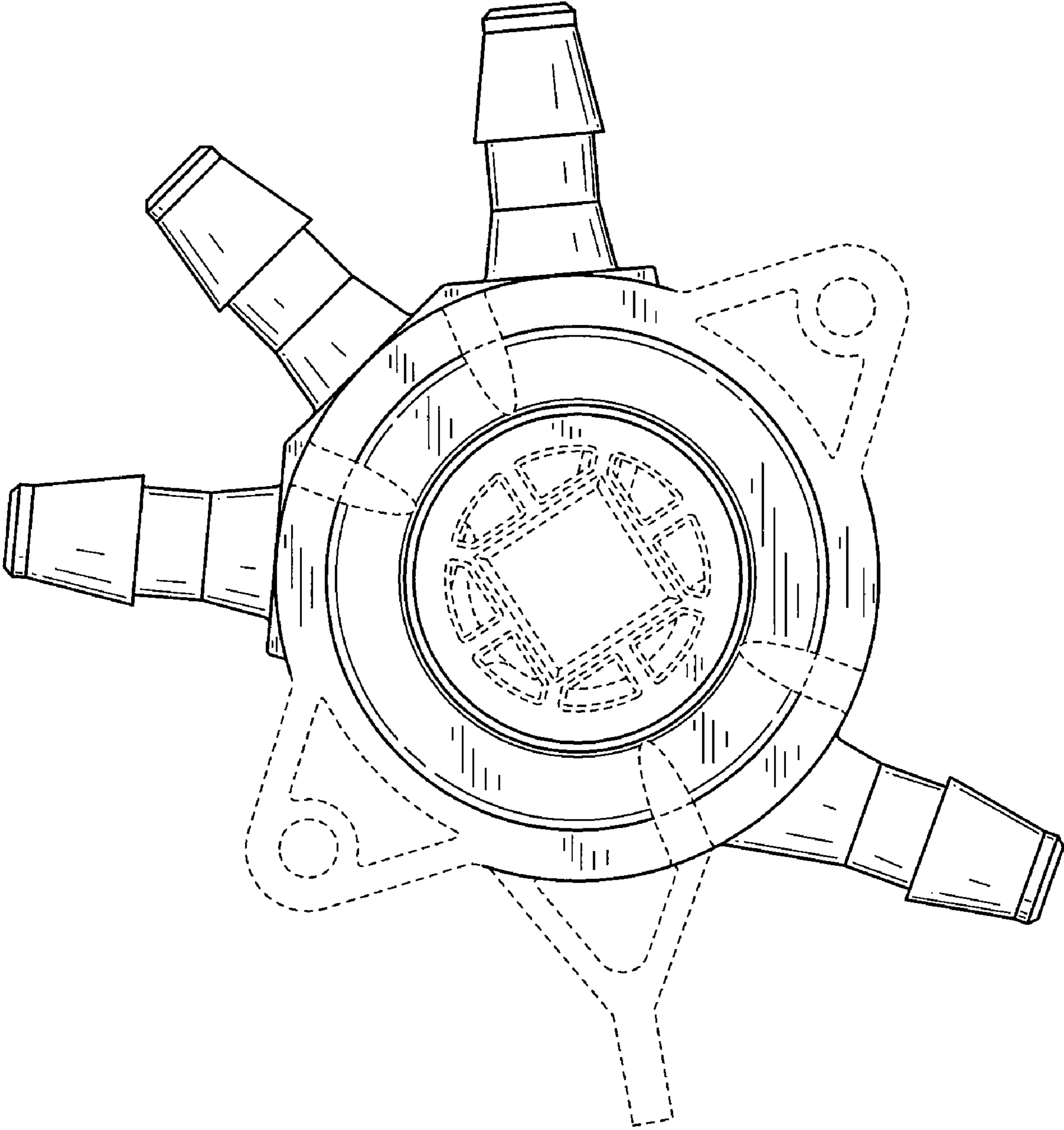

FIG.4

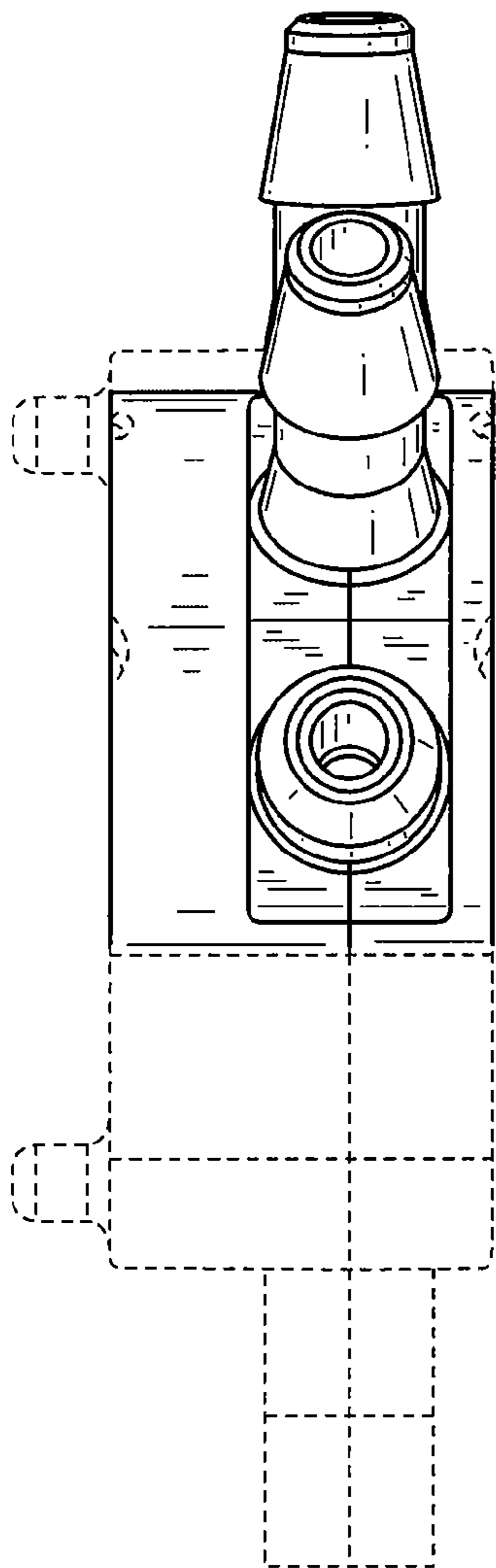

FIG. 5

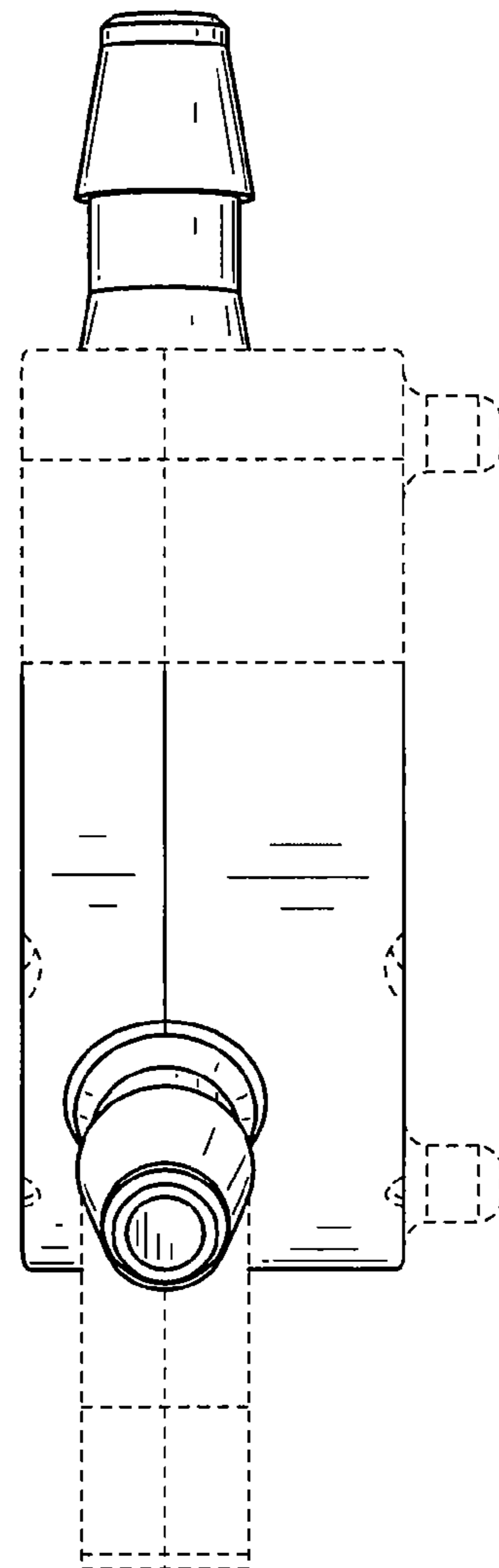

FIG. 6

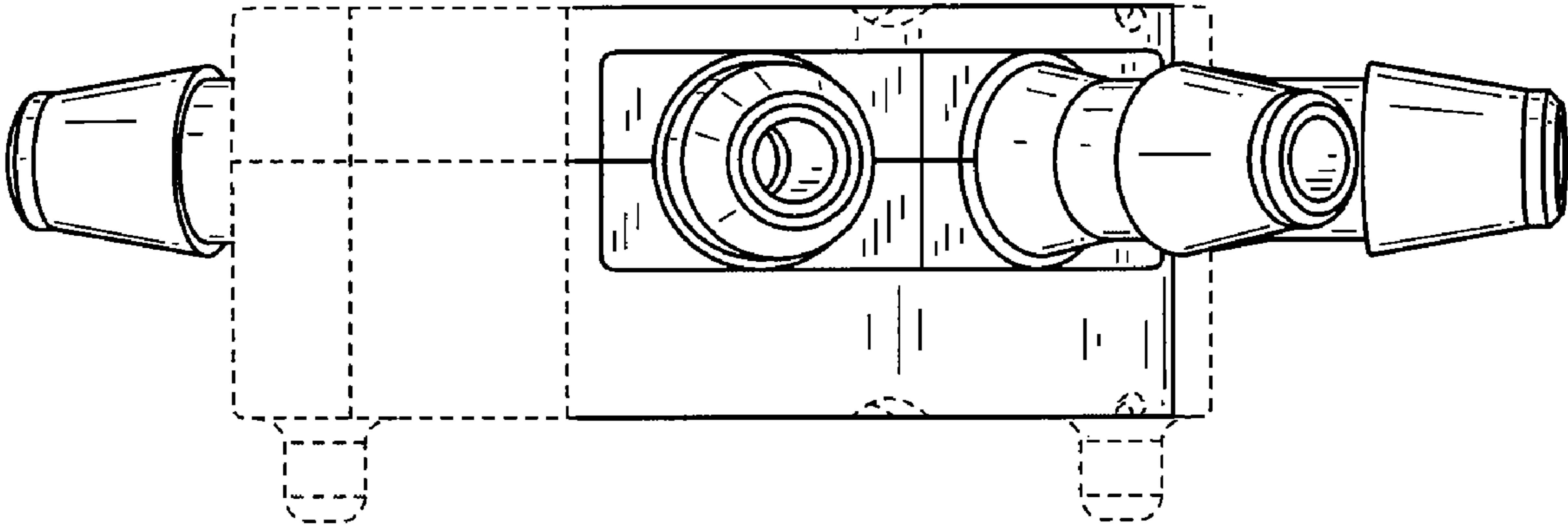

FIG. 7

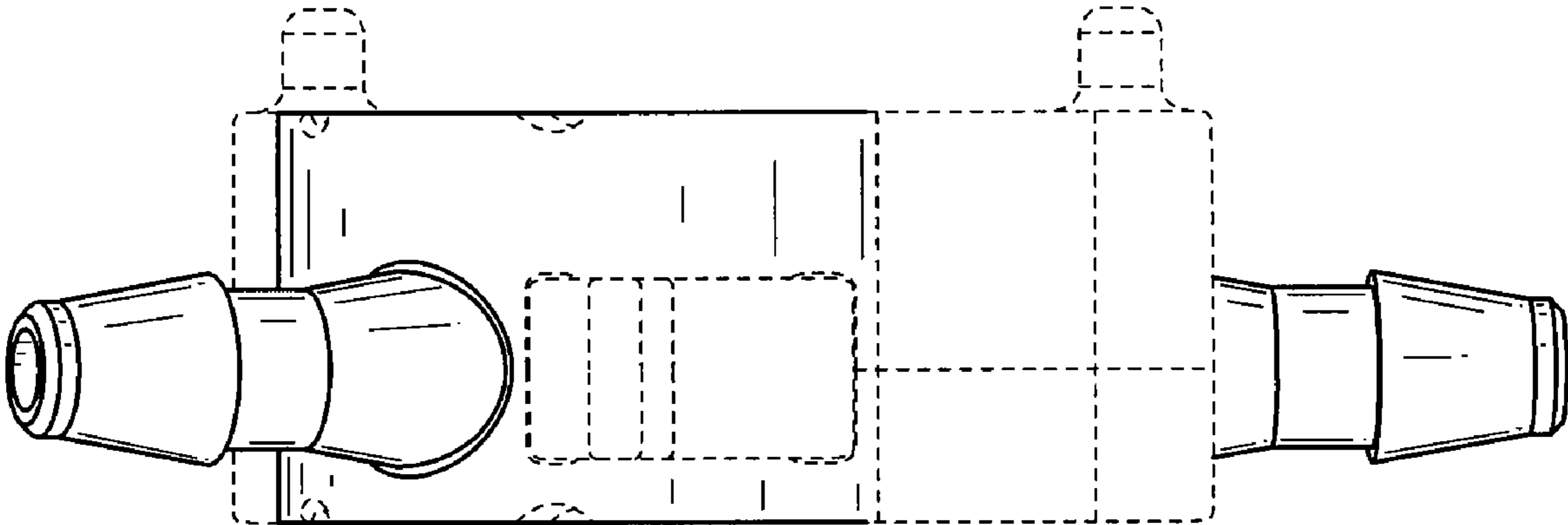

FIG. 8

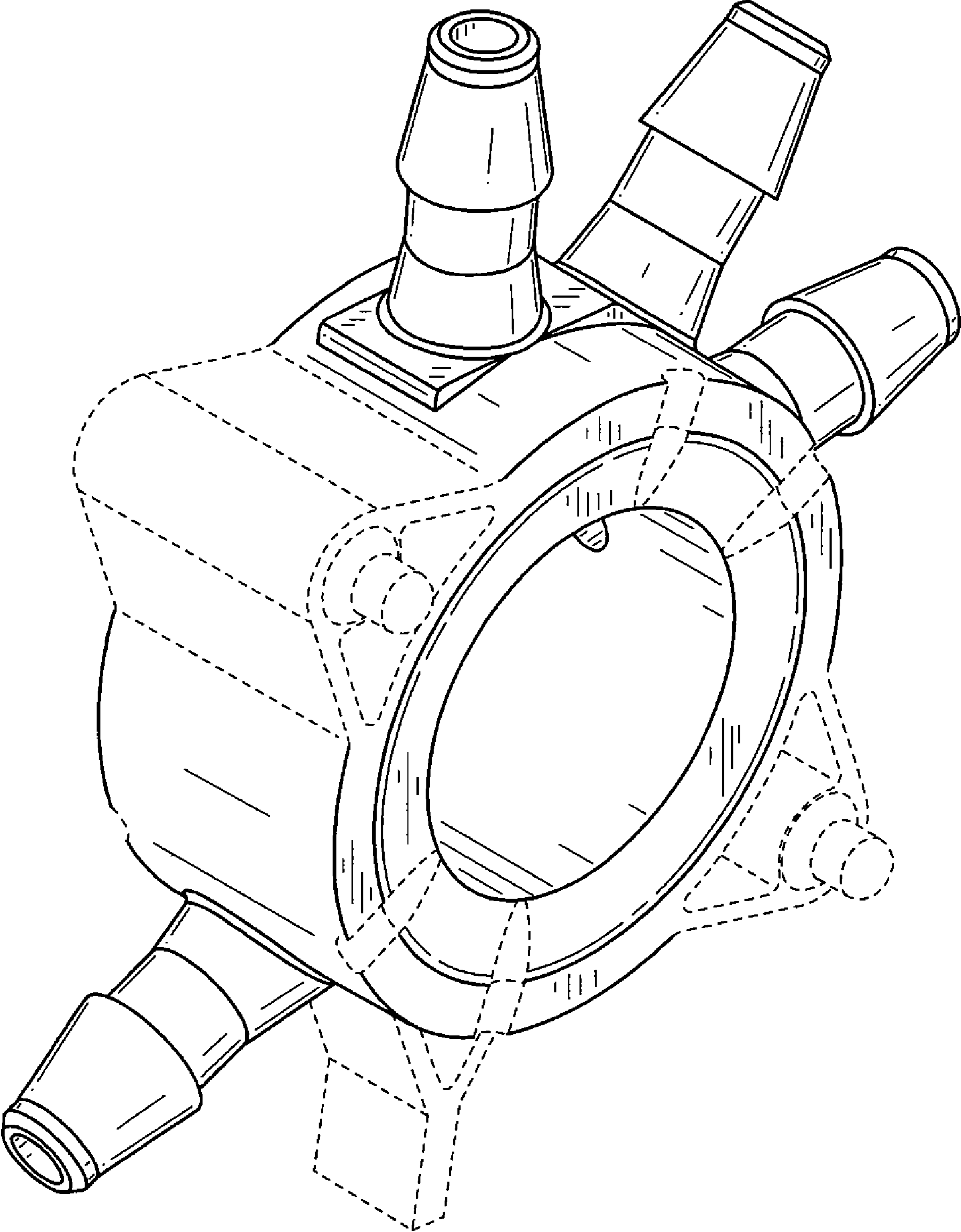

FIG.9

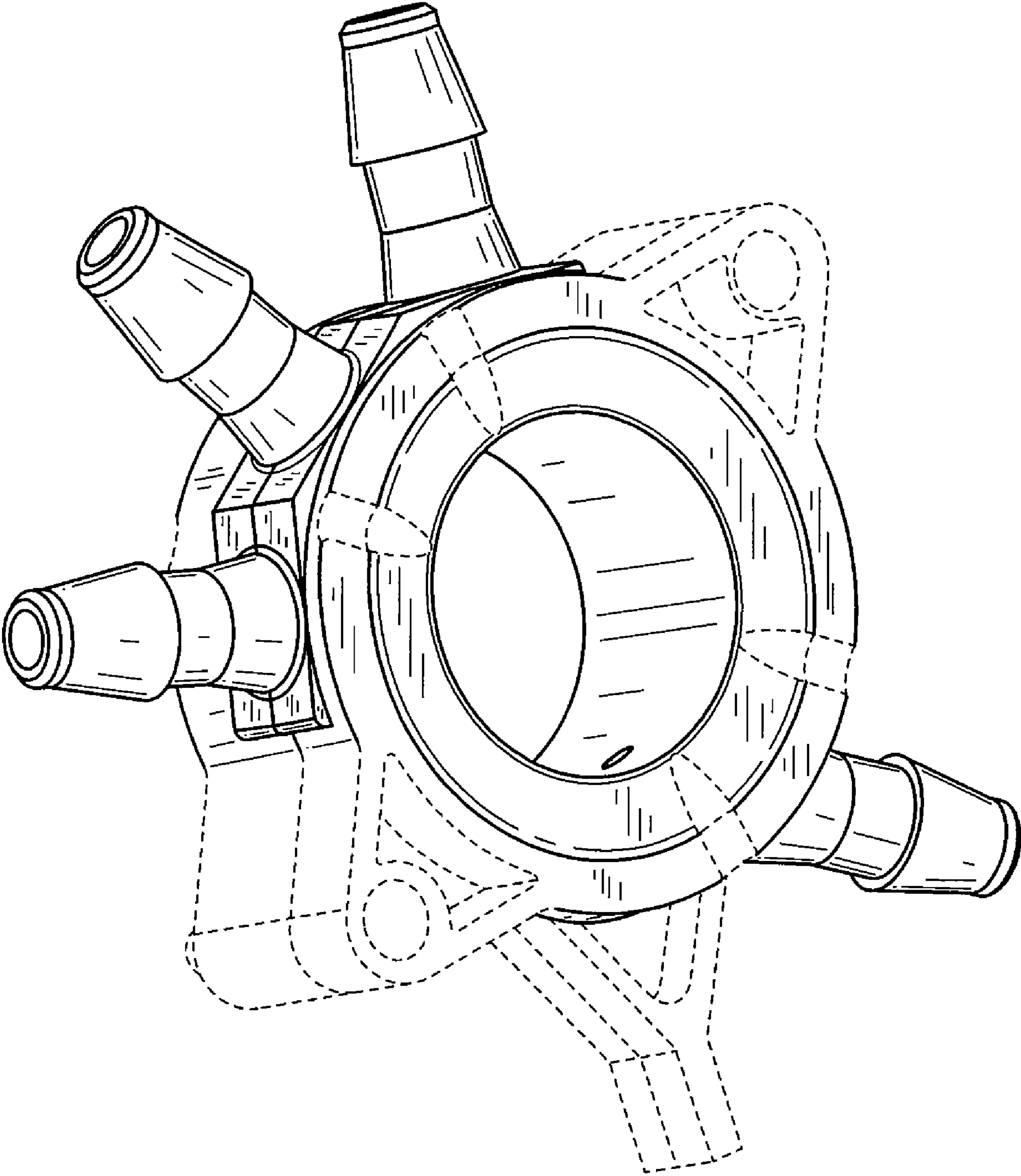

FIG.10

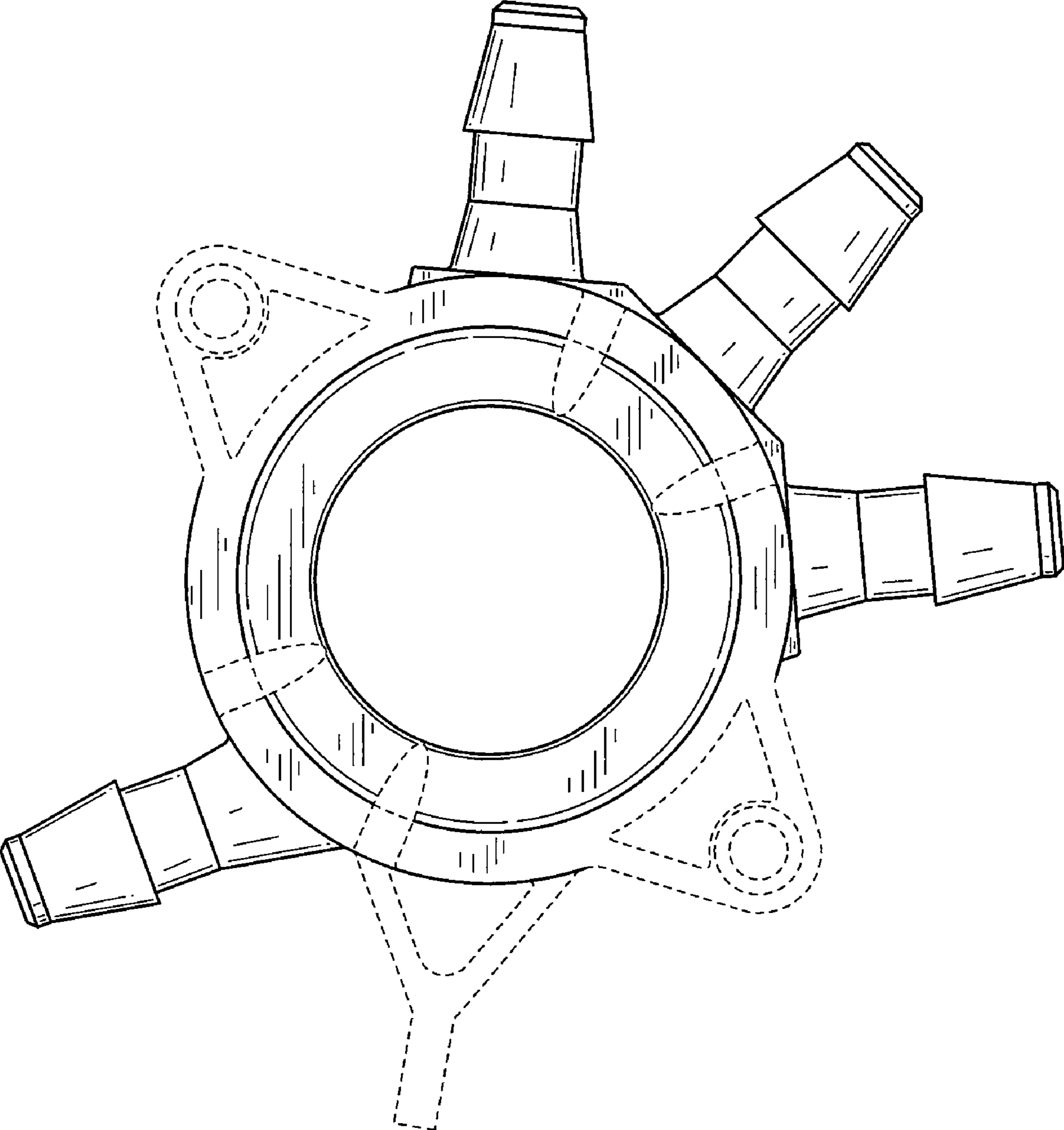

FIG.11

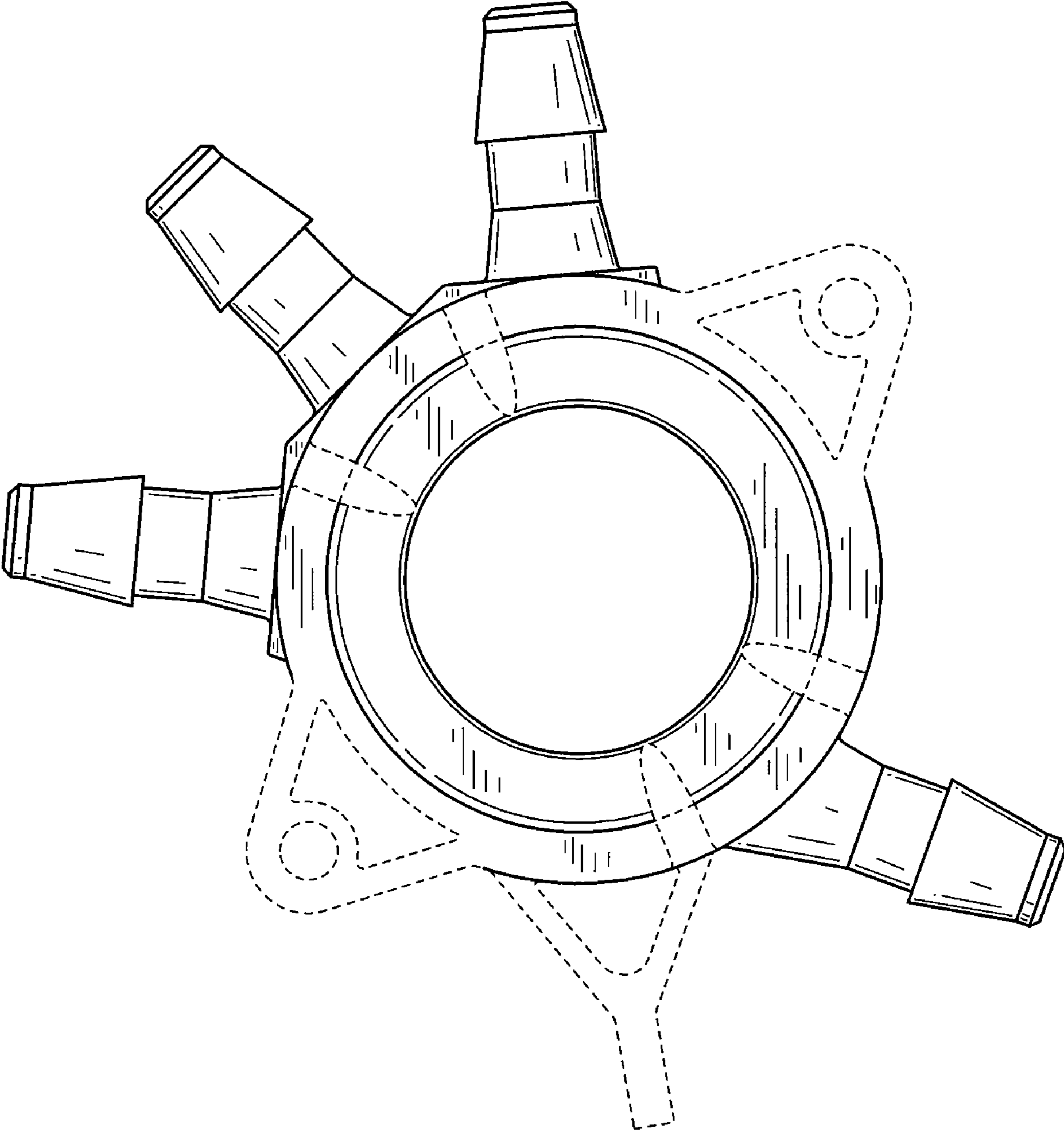

FIG.12

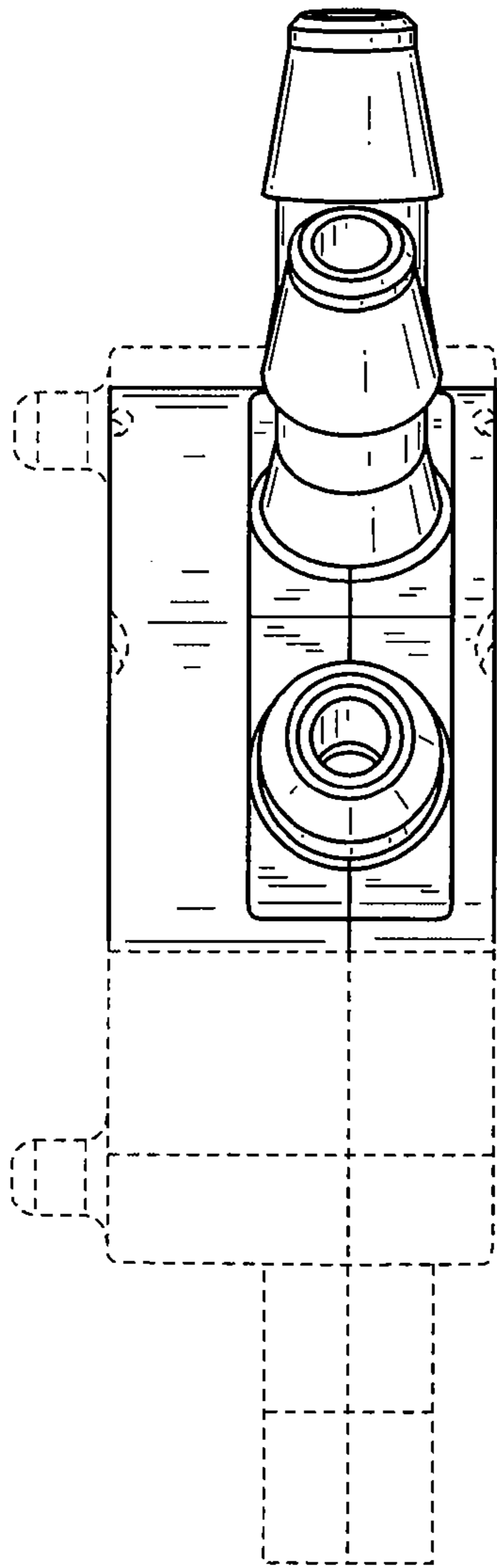

FIG.13

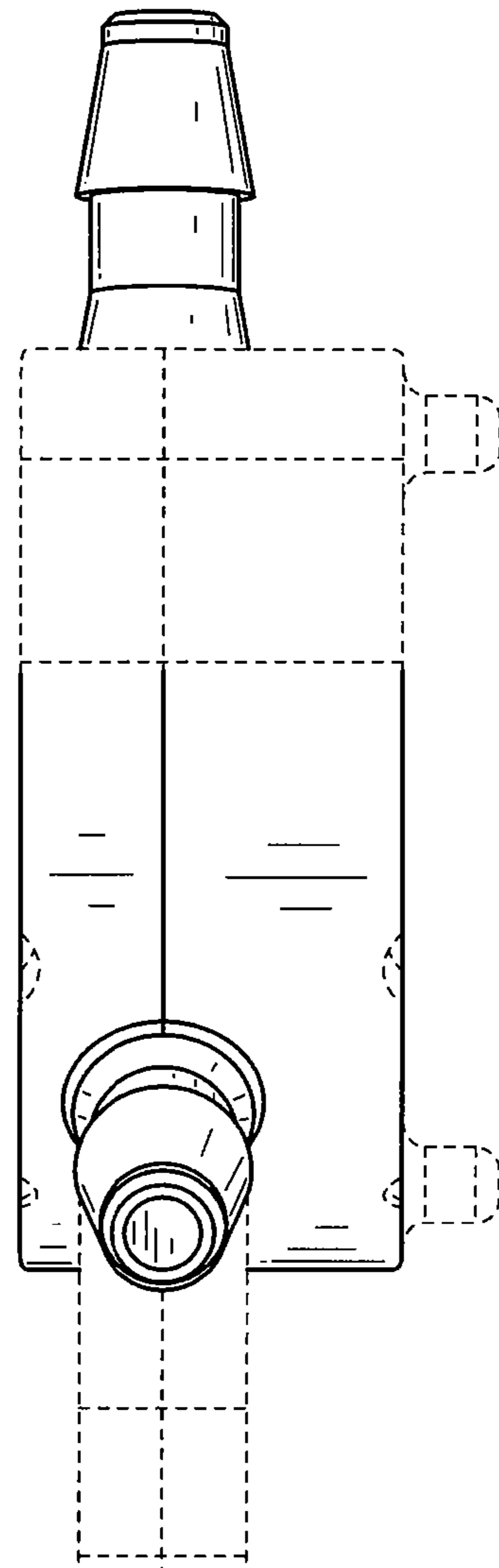

FIG.14

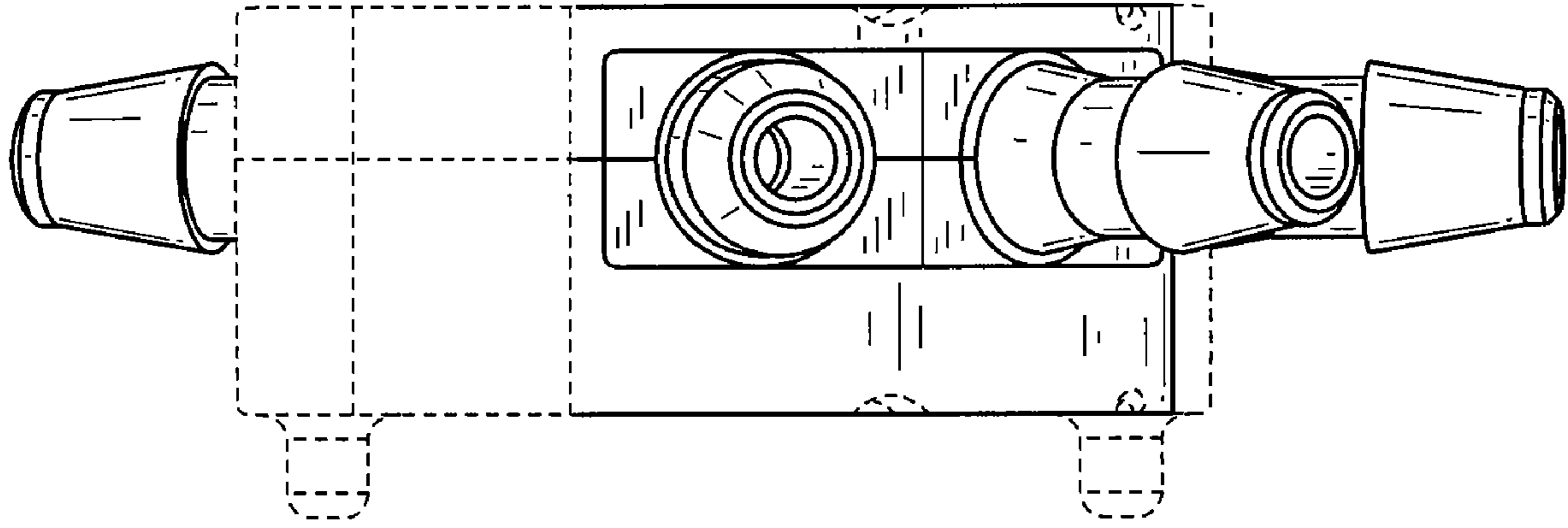

FIG. 15

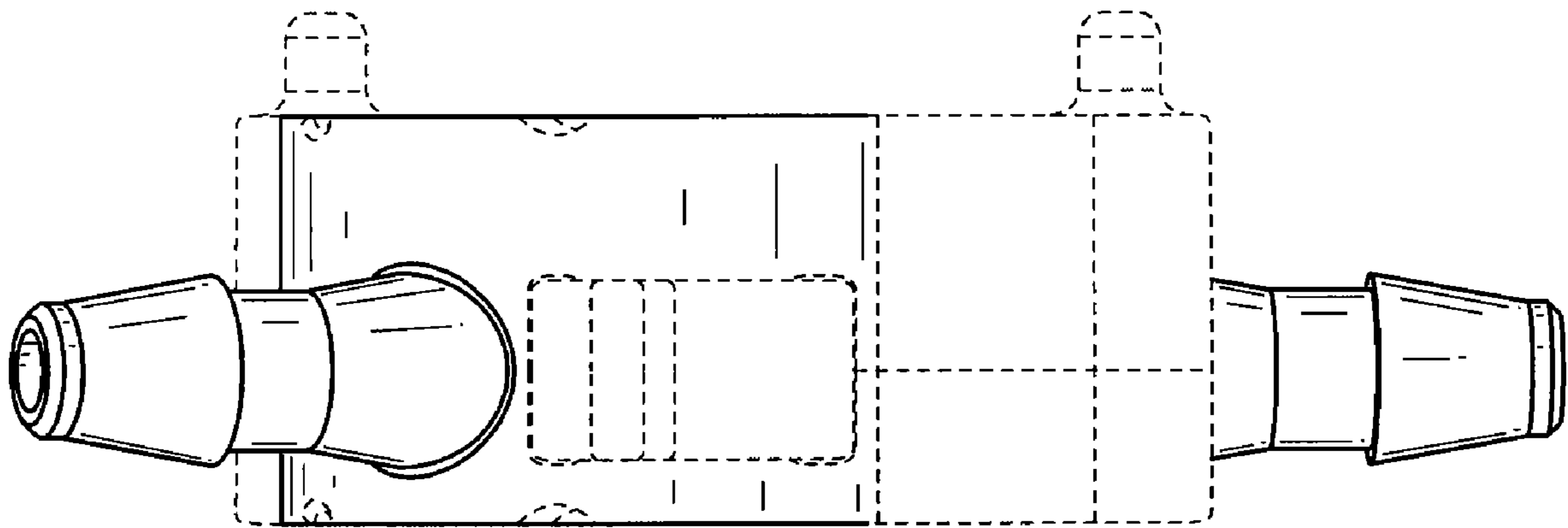

FIG. 16