



US00D655312S

(12) **United States Design Patent**  
**Koyama et al.**

(10) **Patent No.:** **US D655,312 S**  
(45) **Date of Patent:** **\*\* Mar. 6, 2012**

(54) **ROTATION PUMP**

(75) Inventors: **Hideki Koyama**, Okazaki (JP); **Kenzou Kiyose**, Takahama (JP); **Rihito Asai**, Kariya (JP)

(73) Assignee: **Denso Corporation**, Kariya (JP)

(\*\*) Term: **14 Years**

(21) Appl. No.: **29/385,557**

(22) Filed: **Feb. 16, 2011**

(30) **Foreign Application Priority Data**

Sep. 8, 2010 (JP) ..... 2010-021702  
Sep. 8, 2010 (JP) ..... 2010-021703  
Sep. 8, 2010 (JP) ..... 2010-021704

(51) **LOC (9) Cl.** ..... **15-02**

(52) **U.S. Cl.** ..... **D15/7**

(58) **Field of Classification Search** ..... D15/7-9;  
D23/231, 232; 417/410.1, 359, 415-416,  
417/234, 321, 265, 405, 313

See application file for complete search history.

(56) **References Cited**

**U.S. PATENT DOCUMENTS**

D443,881 S \* 6/2001 Tsai ..... D15/7  
D520,026 S \* 5/2006 Hulks ..... D15/9  
D540,350 S \* 4/2007 Hulks ..... D15/9  
D558,233 S \* 12/2007 Itani ..... D15/7

**FOREIGN PATENT DOCUMENTS**

JP 2009-222055 10/2009

\* cited by examiner

*Primary Examiner* — Ralf Seifert

(74) *Attorney, Agent, or Firm* — Nixon & Vanderhye PC

(57) **CLAIM**

The design for a rotation pump, as shown and described.

**DESCRIPTION**

FIG. 1 is a front perspective view of a rotation pump showing the first embodiment of our new design;

FIG. 2 is a rear perspective view of the rotation pump shown in FIG. 1.

FIG. 3 is a front view of the rotation pump shown in FIG. 1; FIG. 4 is a back view of the rotation pump shown in FIG. 1; FIG. 5 is a left side view of the rotation pump shown in FIG. 1;

FIG. 6 is a right side view of the rotation pump shown in FIG. 1;

FIG. 7 is a top view of the rotation pump shown in FIG. 1; FIG. 8 is a bottom view of the rotation pump shown in FIG. 1; FIG. 9 is a front perspective view of a rotation pump showing a second embodiment our new design;

FIG. 10 is a rear perspective view of the rotation pump shown in FIG. 9;

FIG. 11 is a front view of the rotation pump shown in FIG. 9; FIG. 12 is a back view of the rotation pump shown in FIG. 9;

FIG. 13 is a left side view of the rotation pump shown in FIG. 9;

FIG. 14 is a right side view of the rotation pump shown in FIG. 9;

FIG. 15 is a top view of the rotation pump shown in FIG. 9; and,

FIG. 16 is a bottom view of the rotation pump shown in FIG. 9.

The broken lines in FIGS. 7, 8, 15 and 16 are included for the purpose of illustrating portions of the rotation pump that form no part of the claimed design.

The article of the present design relates to a rotation pump for supplying fuel to an internal combustion engine or the like. The rotation pump includes a motor, and an impeller driven and rotated by the motor, and a cylindrical body that houses therein the motor and the impeller. A connector and a cylindrical discharge tube are formed at one end of the body, and a cylindrical intake tube is formed at the other end of the body. When electrical power is supplied to the rotation pump via the connector, the motor is activated so that fuel is drawn from the intake tube and is discharged from the discharge tube.

**1 Claim, 8 Drawing Sheets**

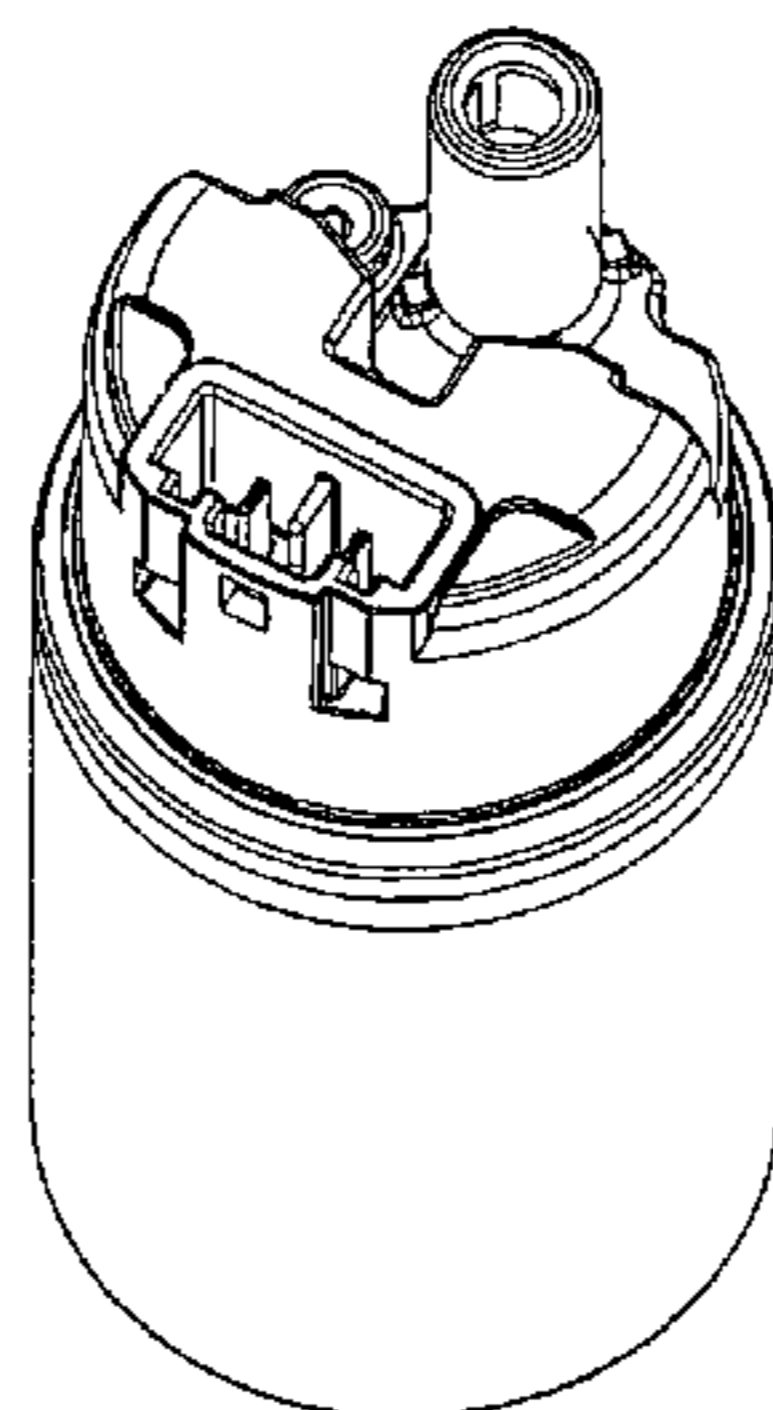

FIG. 1

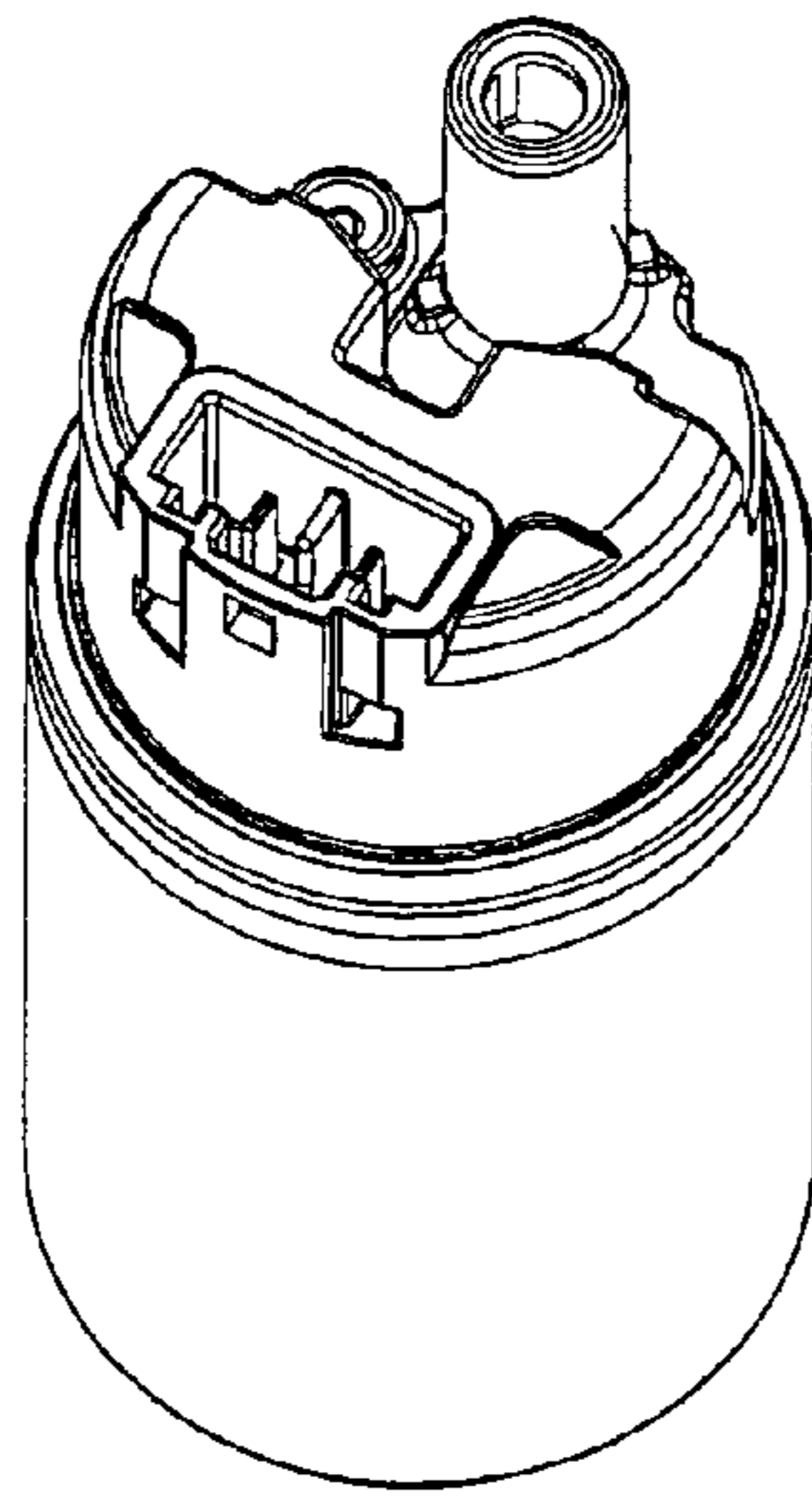

FIG. 2

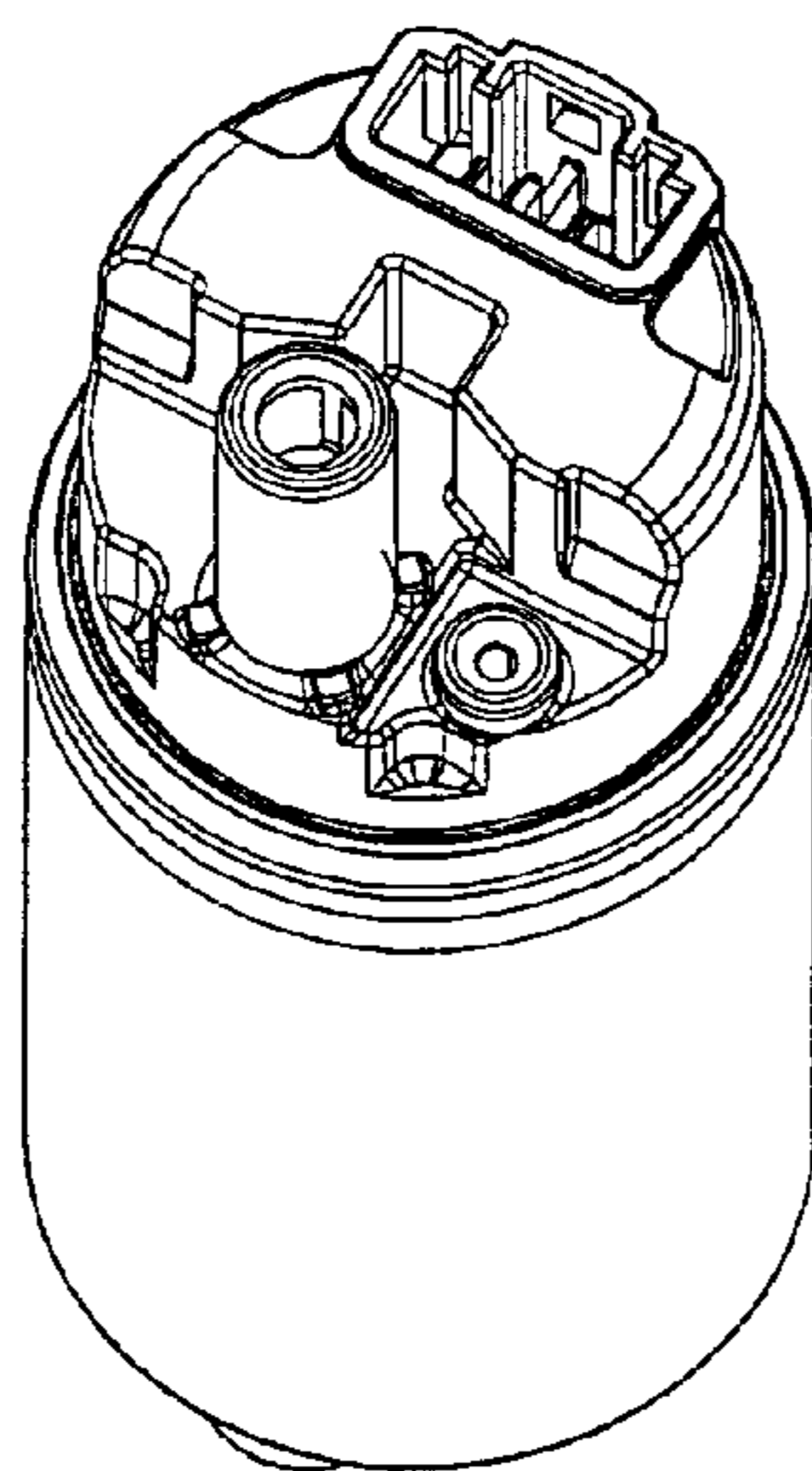

FIG. 3

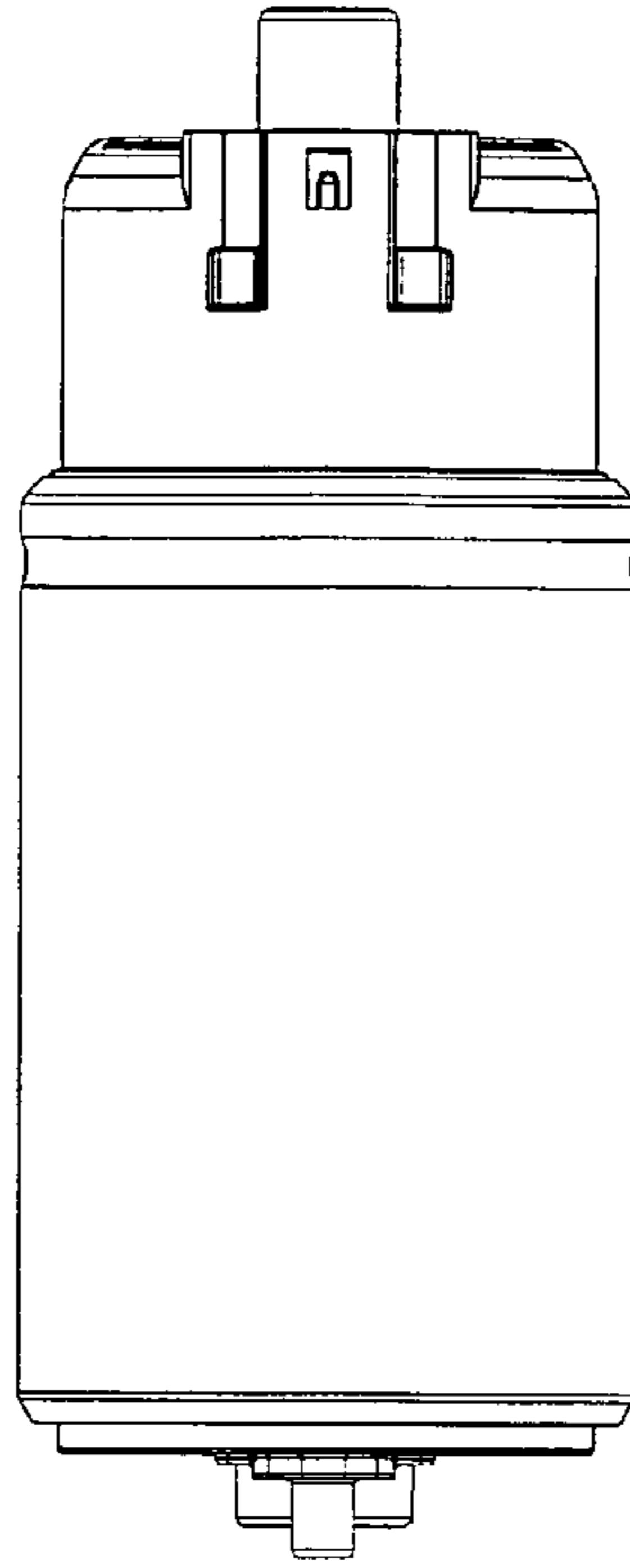

FIG. 4

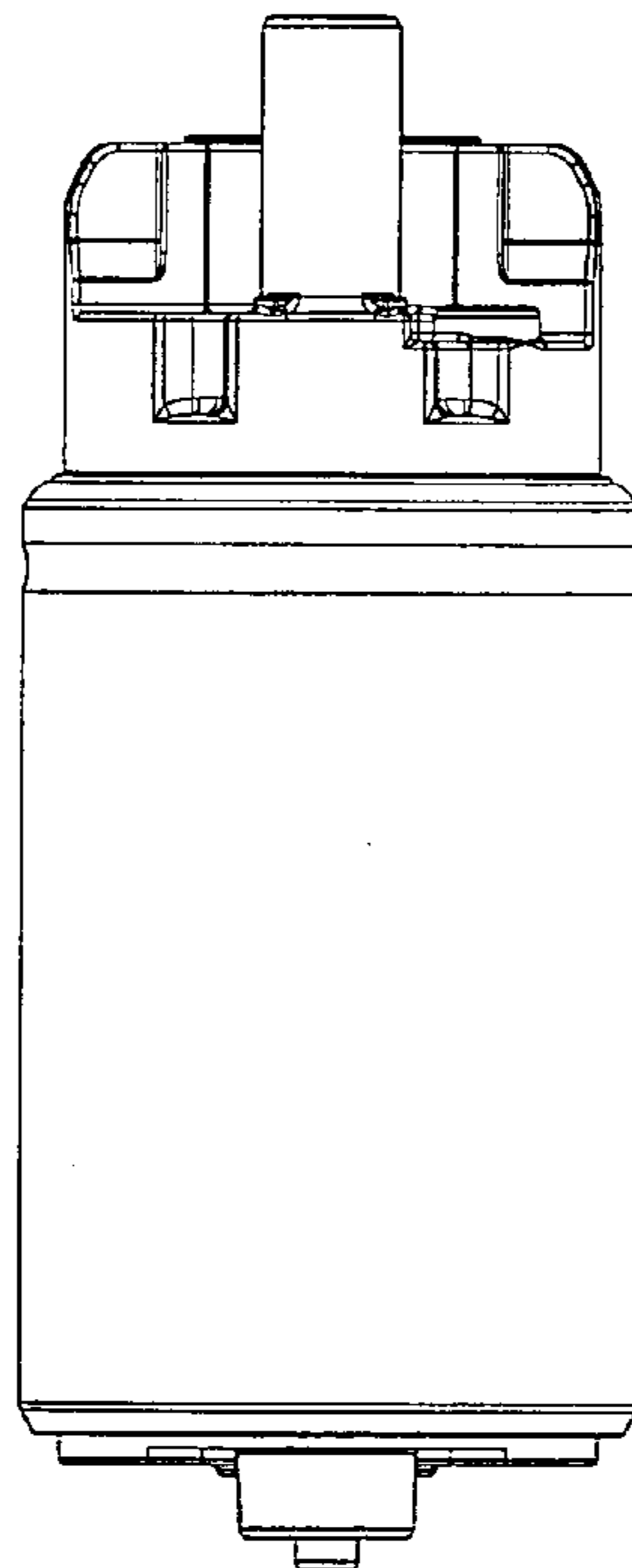

FIG. 5

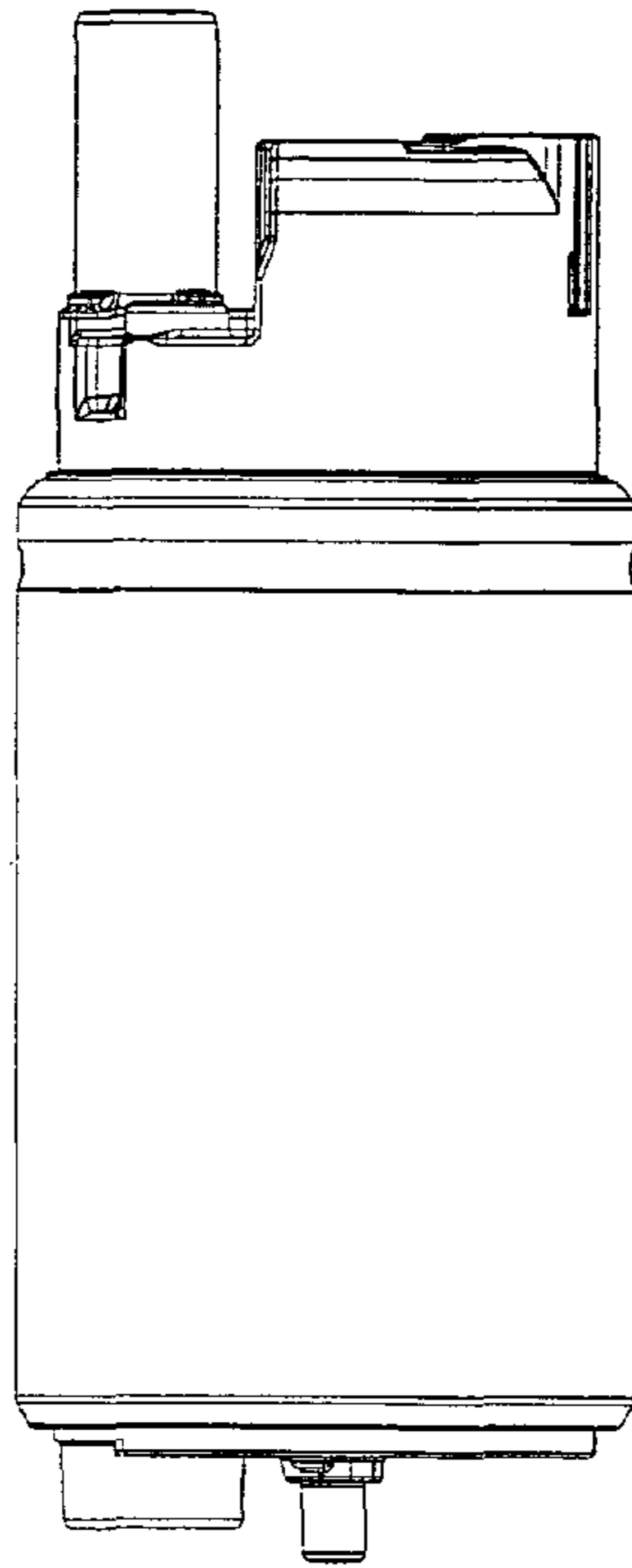

FIG. 6

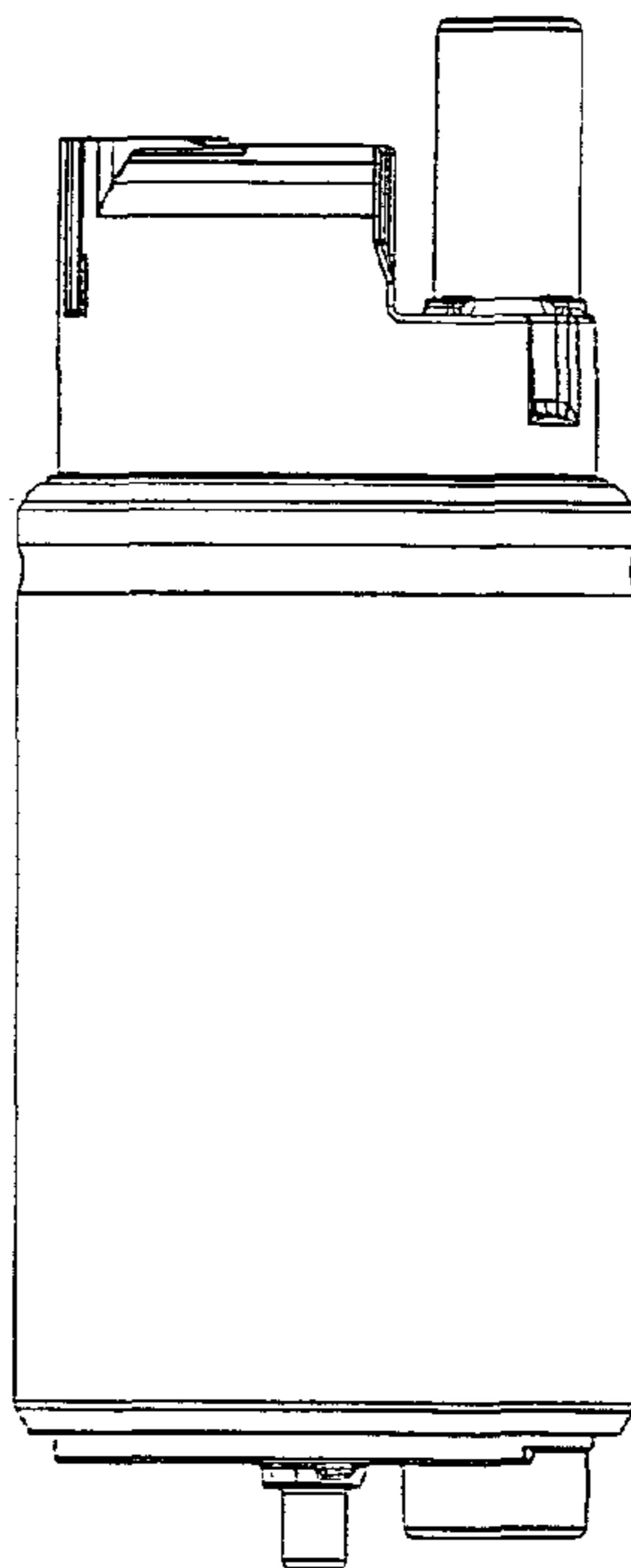

FIG. 7

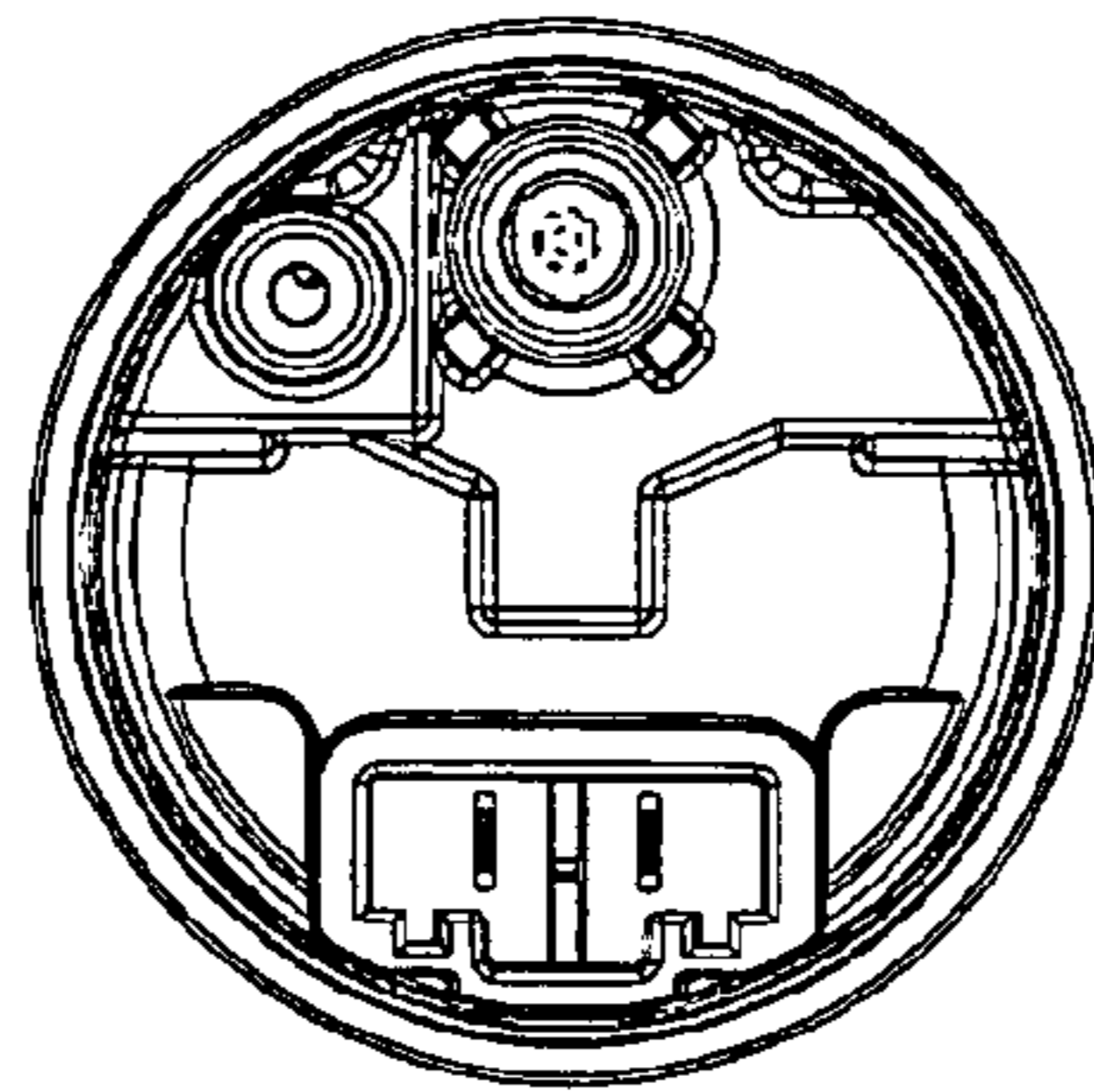

FIG. 8

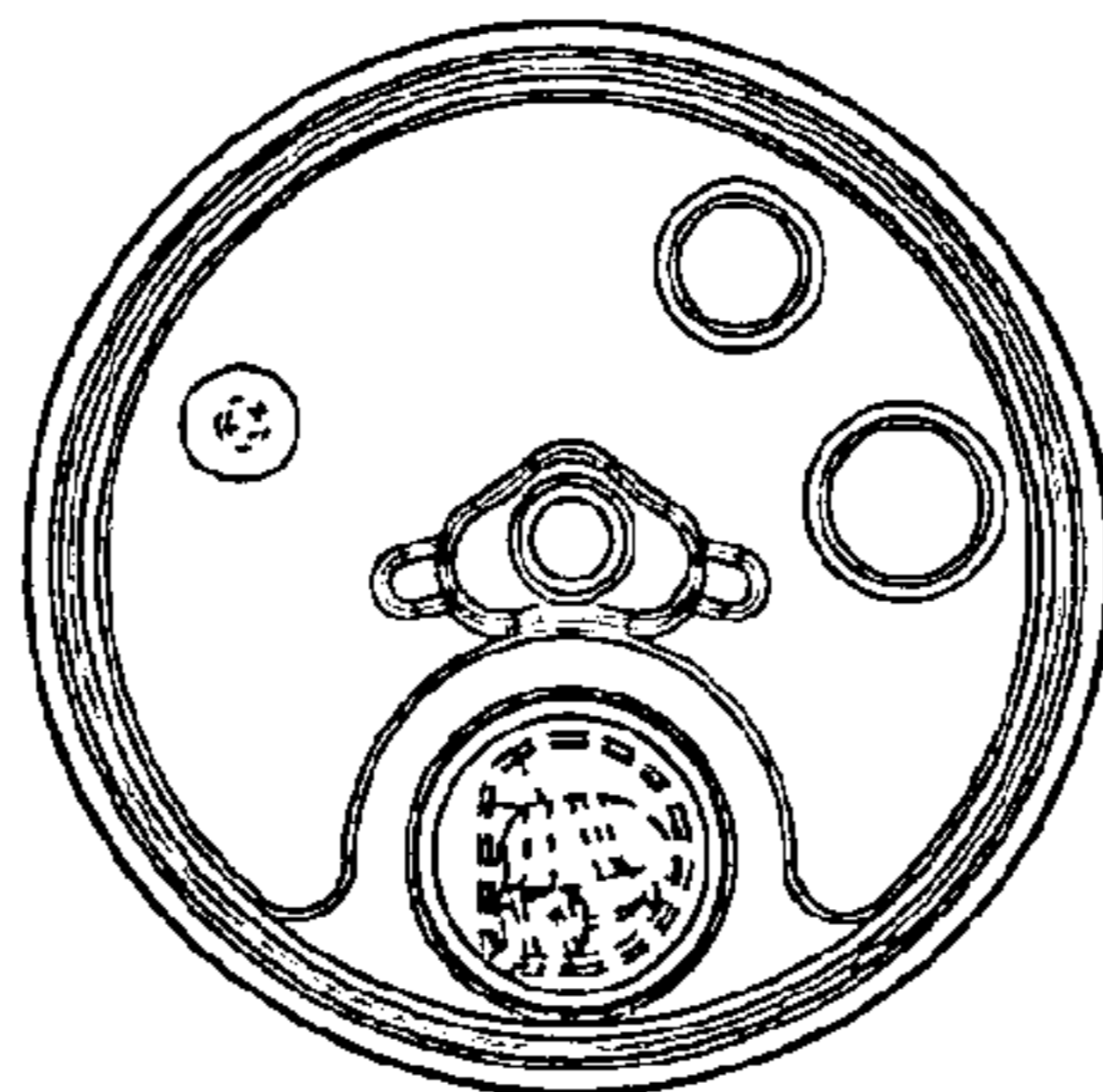

FIG. 9

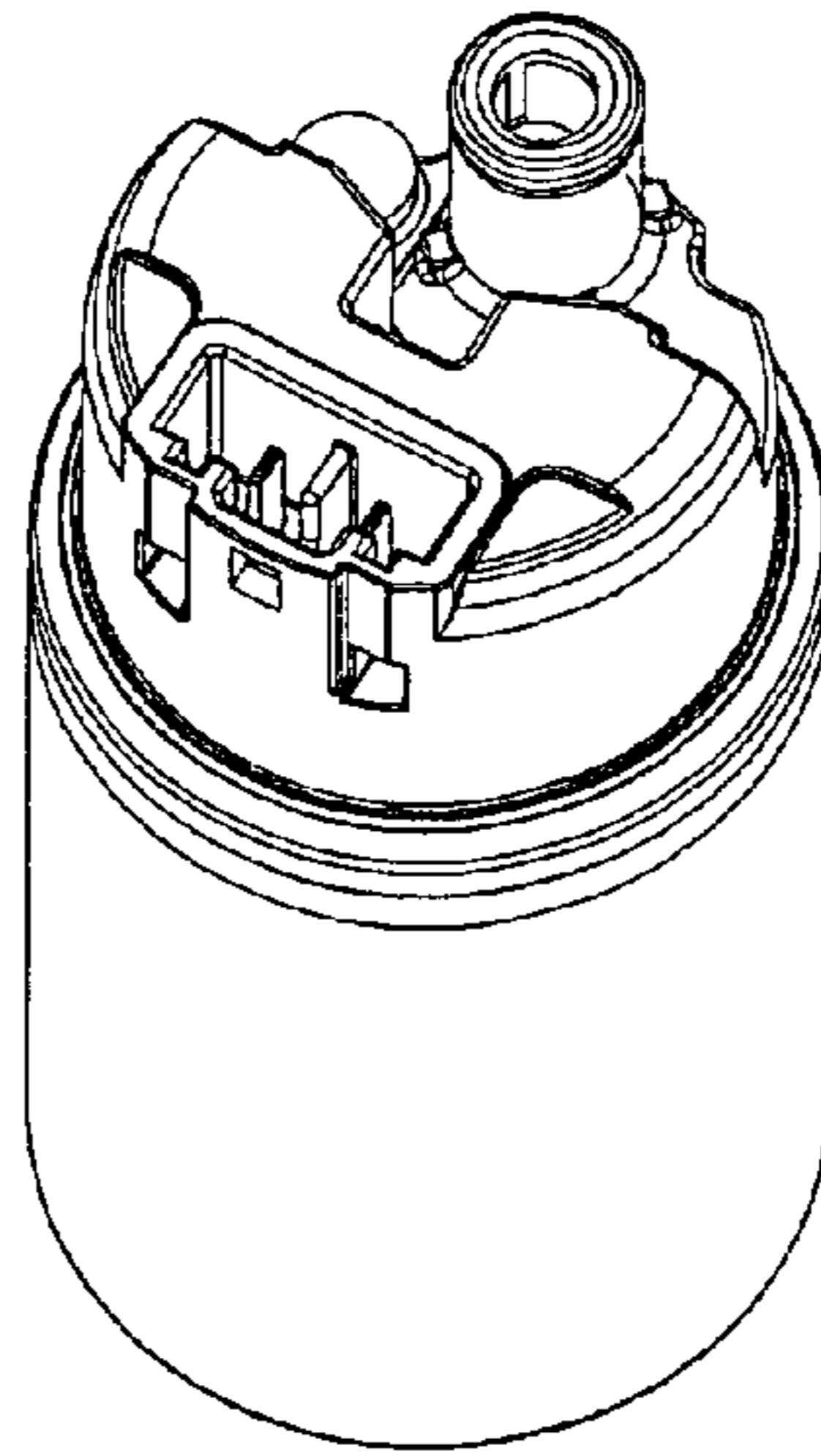

FIG. 10

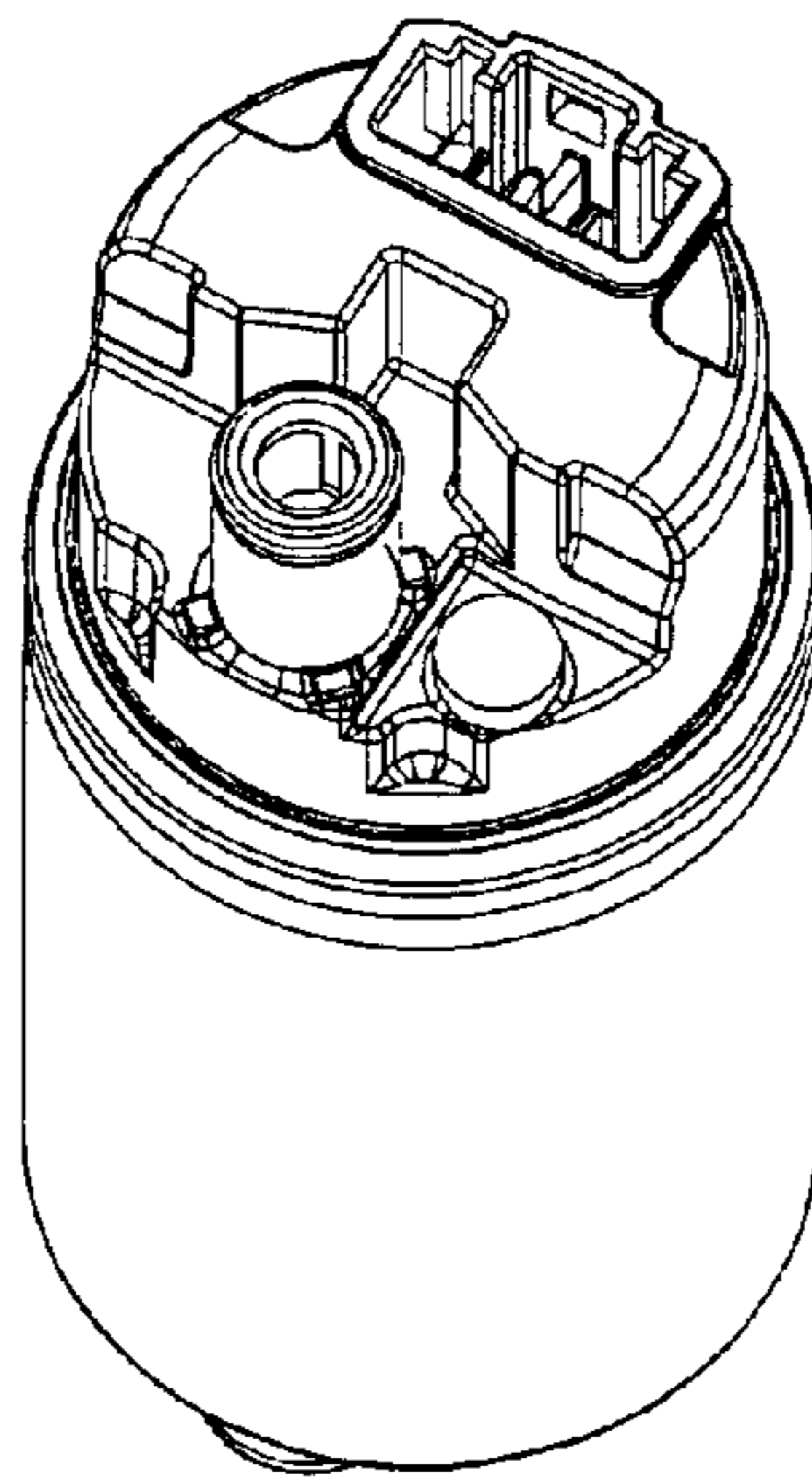

FIG. 11

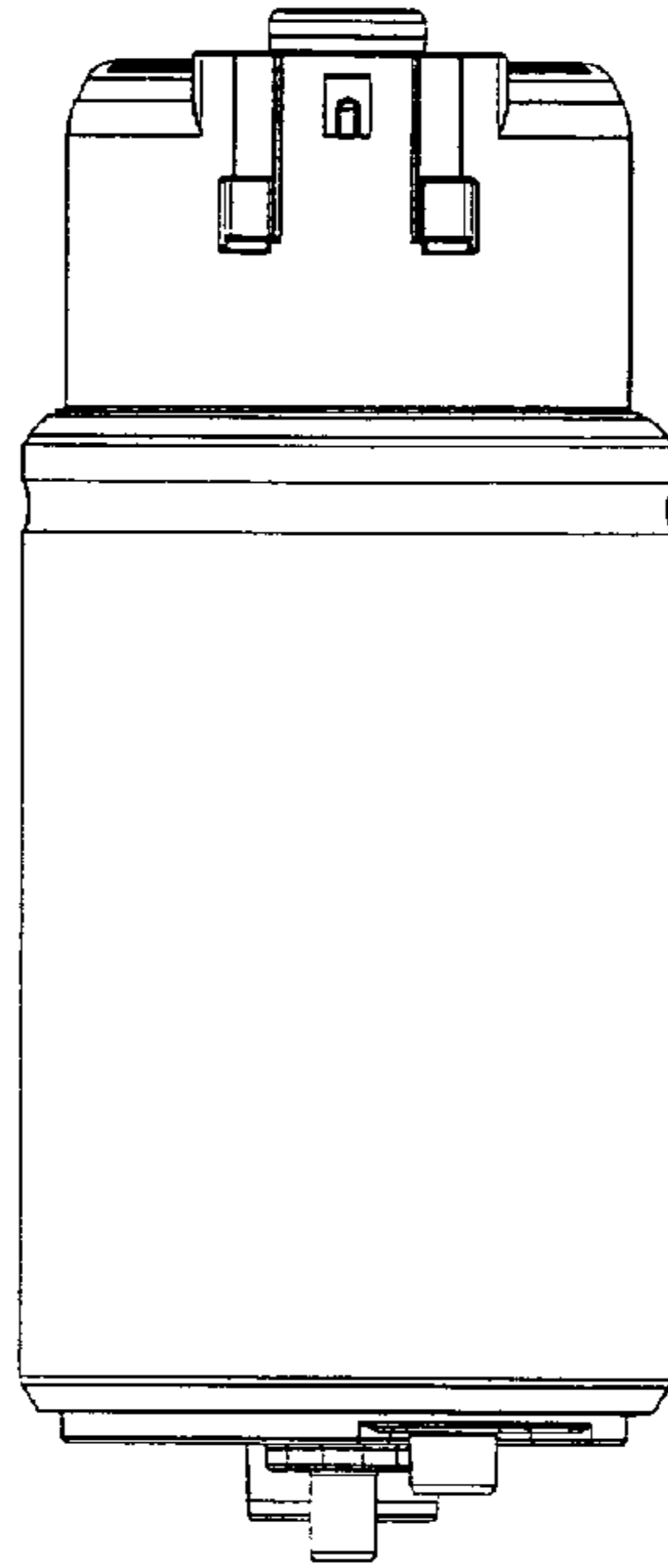

FIG. 12

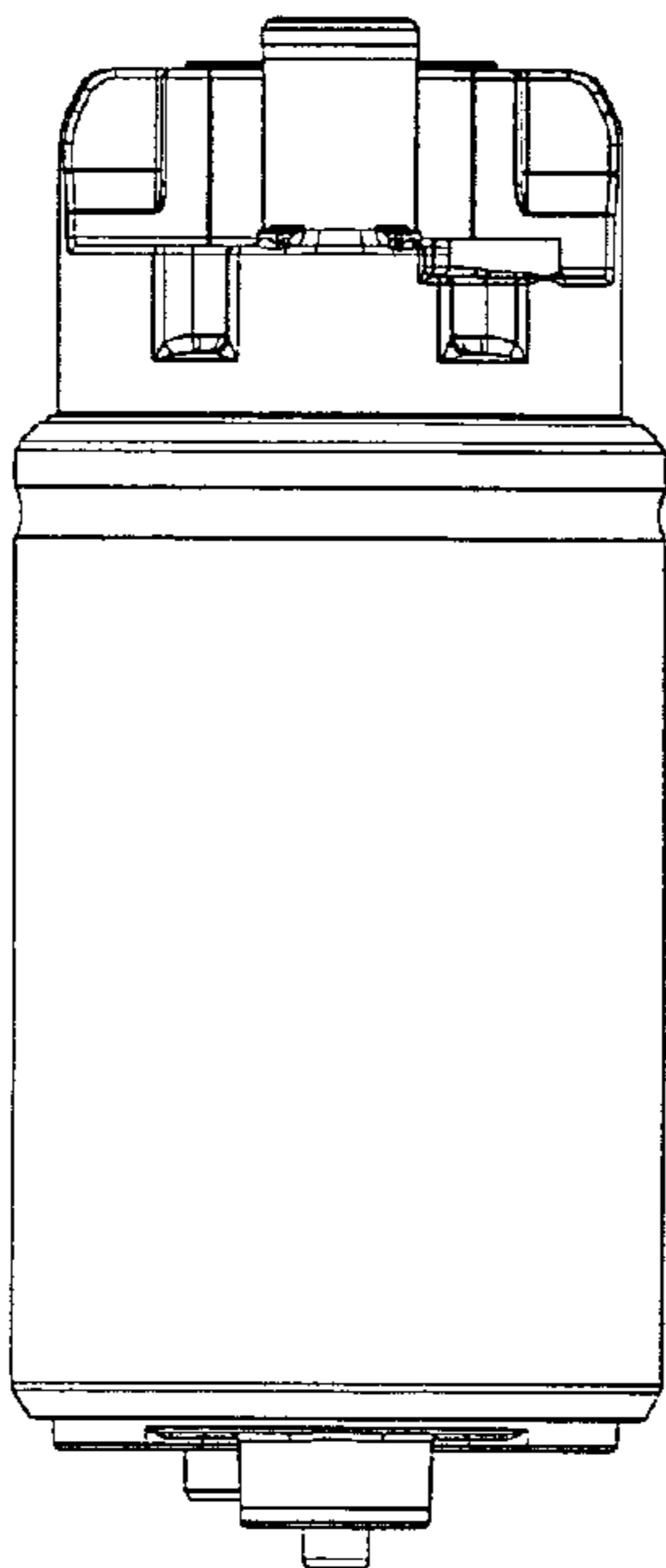

FIG. 13

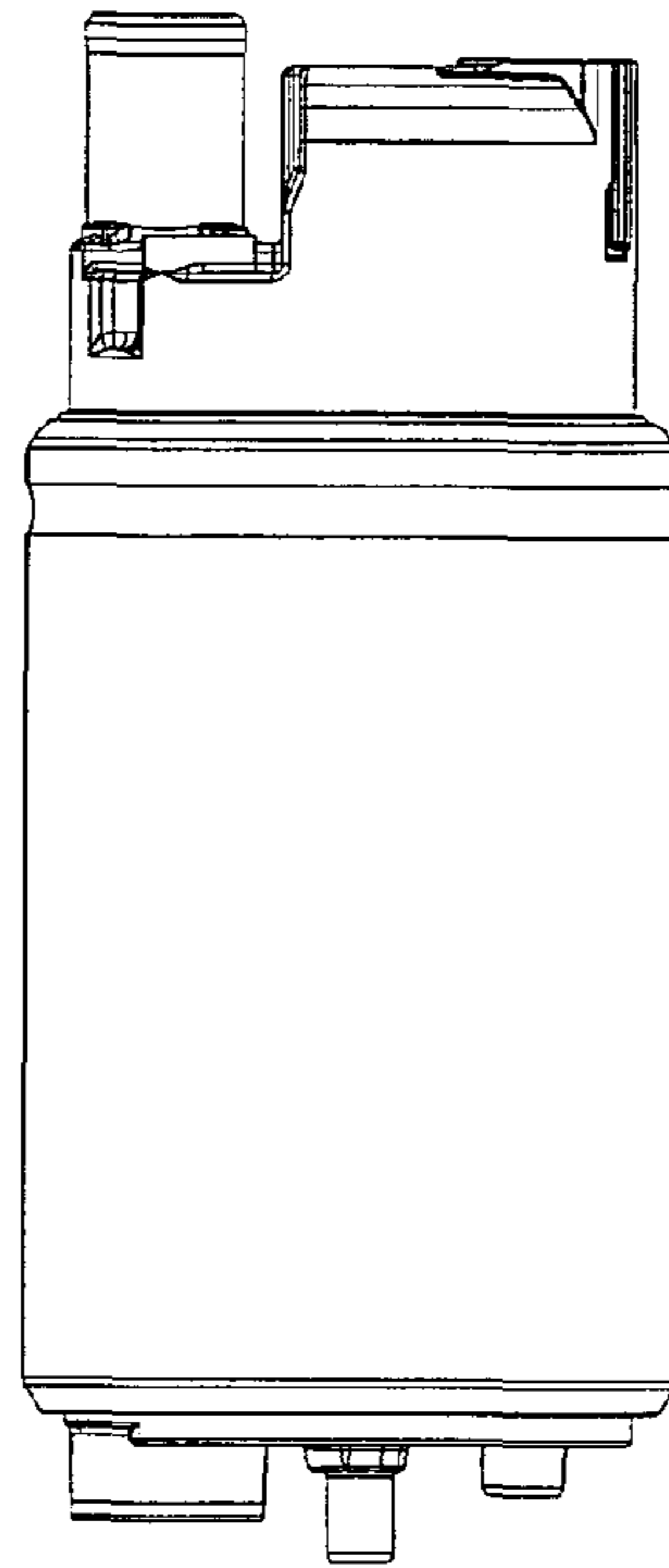

FIG. 14

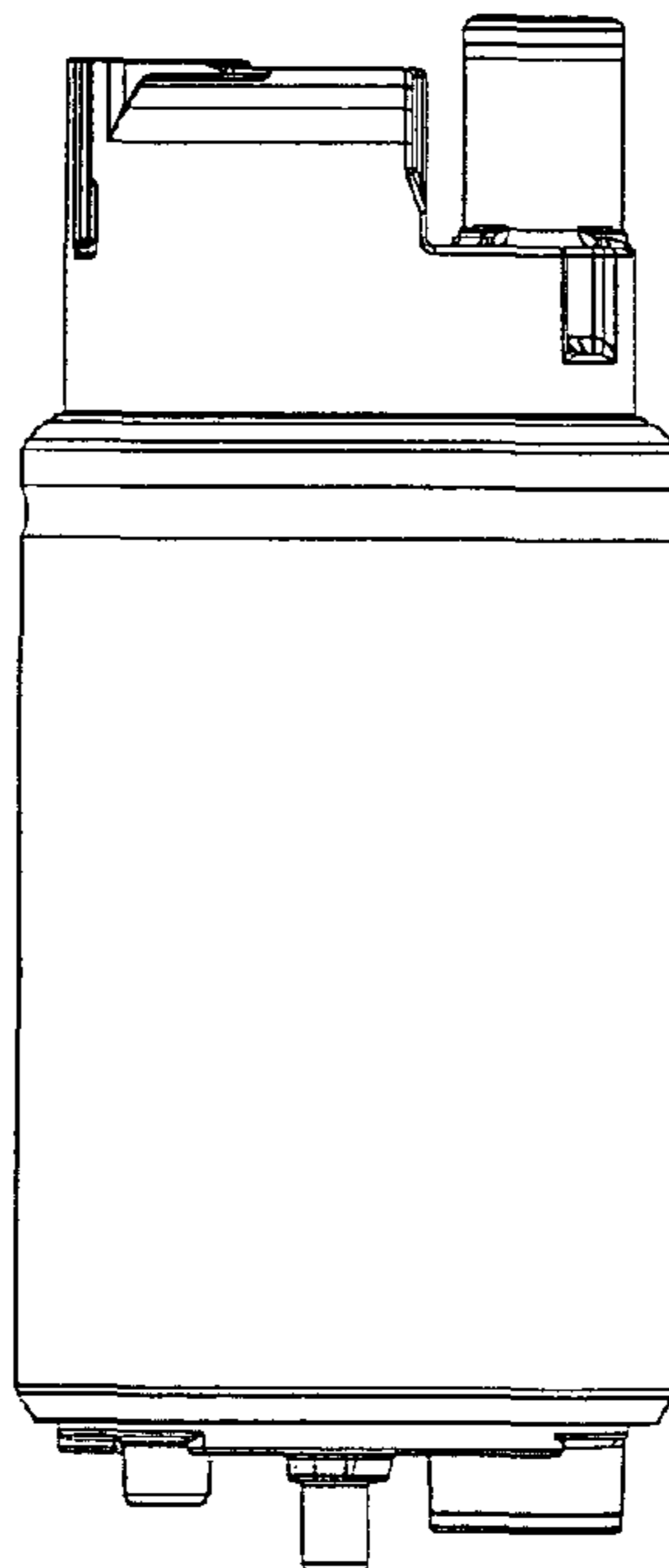



FIG. 15

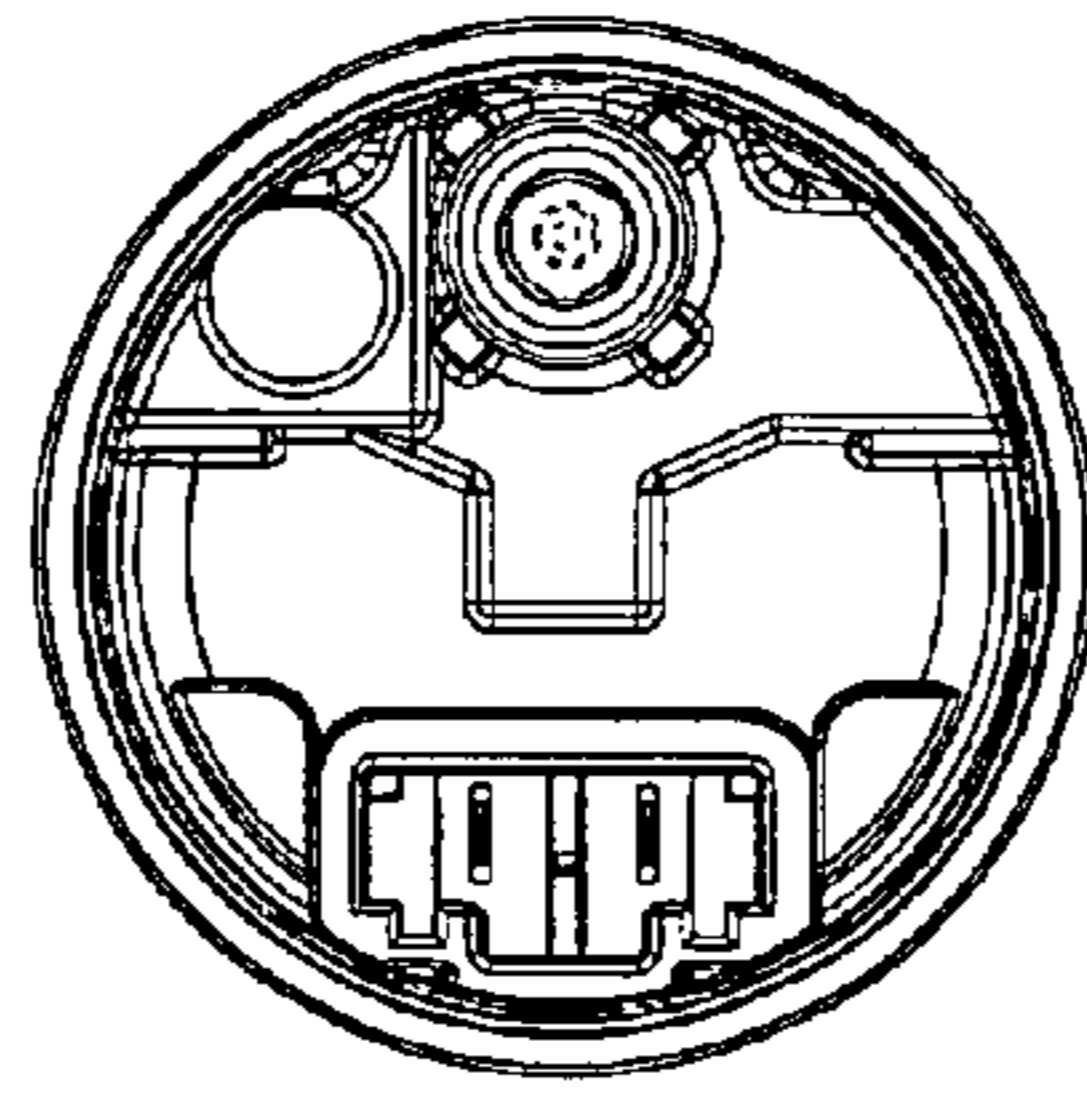

FIG. 16

