



US00D655270S

(12) **United States Design Patent**
Jain et al.

(10) **Patent No.:** **US D655,270 S**
(45) **Date of Patent:** **** Mar. 6, 2012**

(54) **DIGITAL VOICE RECORDER**

(75) Inventors: **Uday Jain**, Lawrenceville, NJ (US);
Manli Zhu, Pearl River, NY (US);
Danny Kopit, Brooklyn, NY (US);
Huixian Tang, Oak Ridge, NJ (US); **Qi Li**, New Providence, NJ (US)

(73) Assignee: **LI Creative Technologies, Inc.**, Florham Park, NJ (US)

(**) Term: **14 Years**

(21) Appl. No.: **29/374,754**

(22) Filed: **Oct. 3, 2011**

(51) **LOC (9) Cl.** **14-01**

(52) **U.S. Cl.** **D14/167**

(58) **Field of Classification Search** D14/167,
D14/154, 168, 188, 496, 156, 160, 161, 162,
D14/163, 164, 165, 158, 203.1, 341, 346,
D14/342, 345, 225, 226, 228, 227, 214; 455/351,
455/350; D19/60, 62; D21/330; 369/44.14,
369/44.32; 700/94; D3/208
See application file for complete search history.

(56) **References Cited**

U.S. PATENT DOCUMENTS

D278,707 S * 5/1985 Swinney D14/158
D448,157 S * 9/2001 Wright D3/208

D461,047 S * 8/2002 Peterson D3/208
D495,483 S * 9/2004 Vickers et al. D3/208
D535,306 S * 1/2007 Tokioka D14/203.6
D592,177 S * 5/2009 Dobbs et al. D14/158
D595,686 S * 7/2009 Mosher D14/158
D601,121 S * 9/2009 Chen D14/167
D603,601 S * 11/2009 Ohta et al. D3/207
D605,165 S * 12/2009 Sheba et al. D14/203.7
D605,167 S * 12/2009 Sheba et al. D14/203.7
D624,524 S * 9/2010 Terzigni D14/167
D635,545 S * 4/2011 Sakai D14/167

* cited by examiner

Primary Examiner — Austin Murphy

(57) **CLAIM**

The ornamental design for a digital voice recorder, as shown and described.

DESCRIPTION

FIG. 1. is a front, bottom, and left side perspective view of a digital voice recorder, showing our new design;
FIG. 2. is a rear, top, and right side perspective view thereof;
FIG. 3. is a front view thereof;
FIG. 4. is a rear view thereof;
FIG. 5. is a right side view thereof;
FIG. 6. is a left side view thereof;
FIG. 7. is a top plan view thereof; and,
FIG. 8. is a bottom plan view thereof.

1 Claim, 8 Drawing Sheets

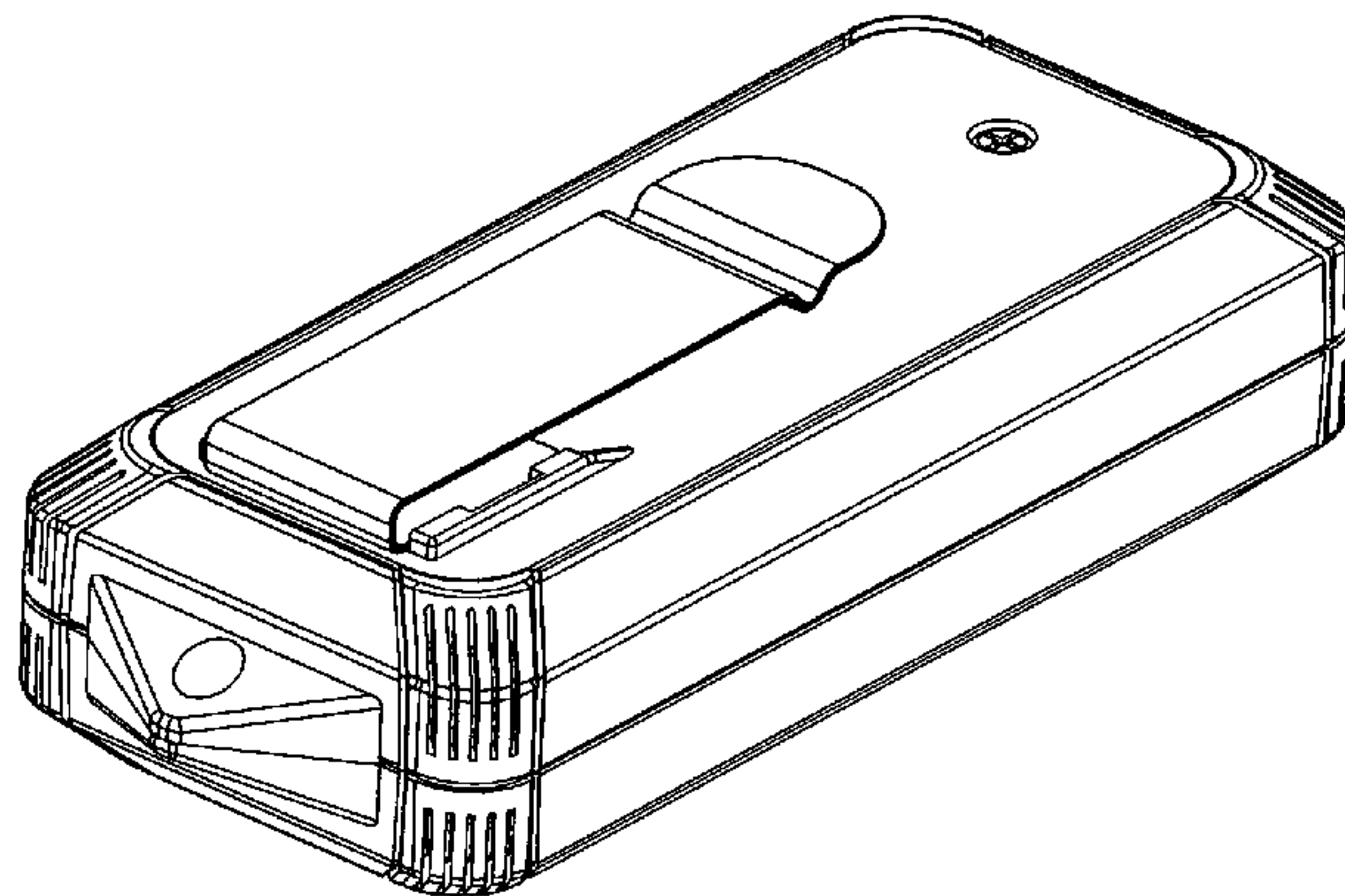
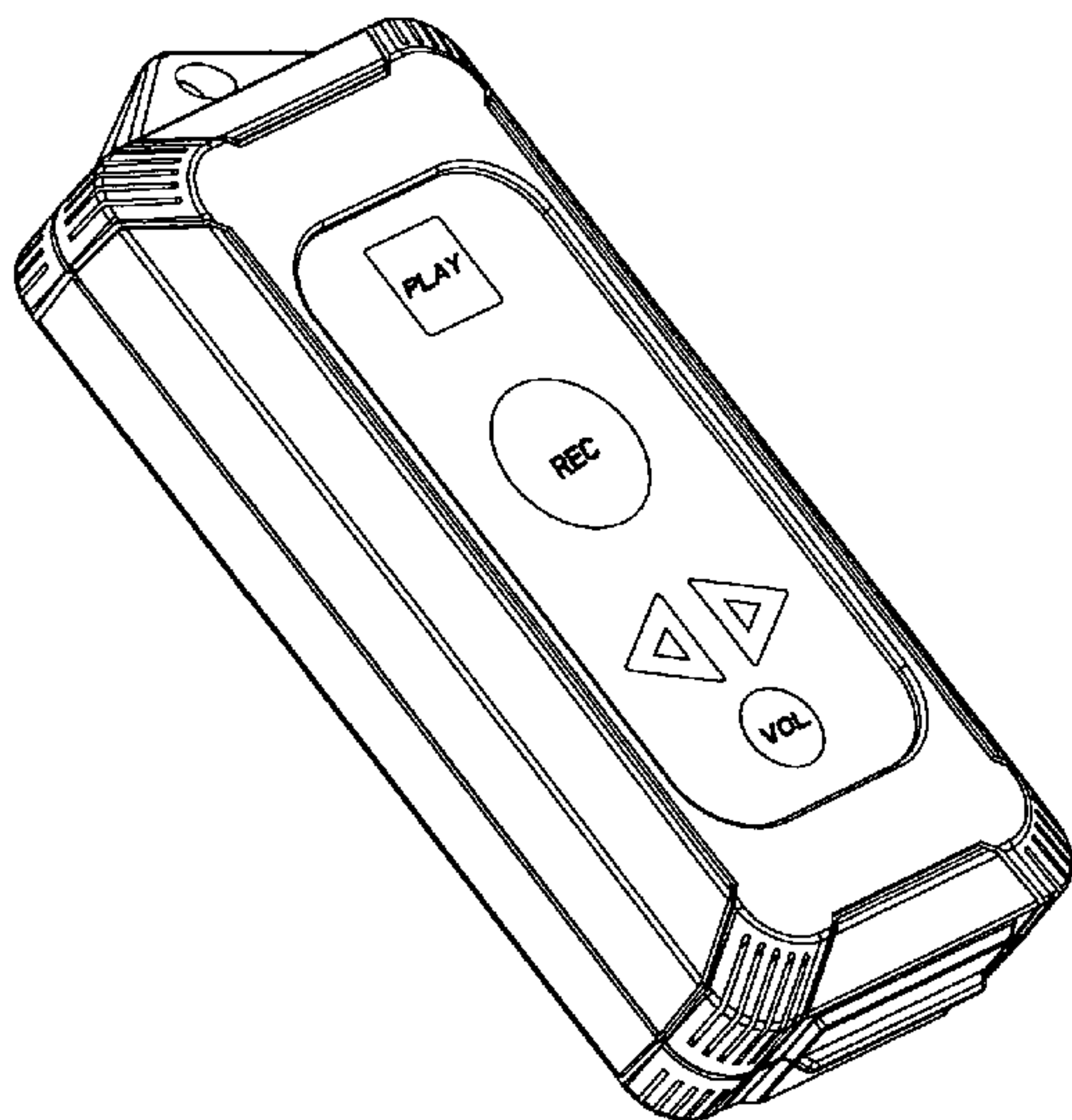

Fig. 1

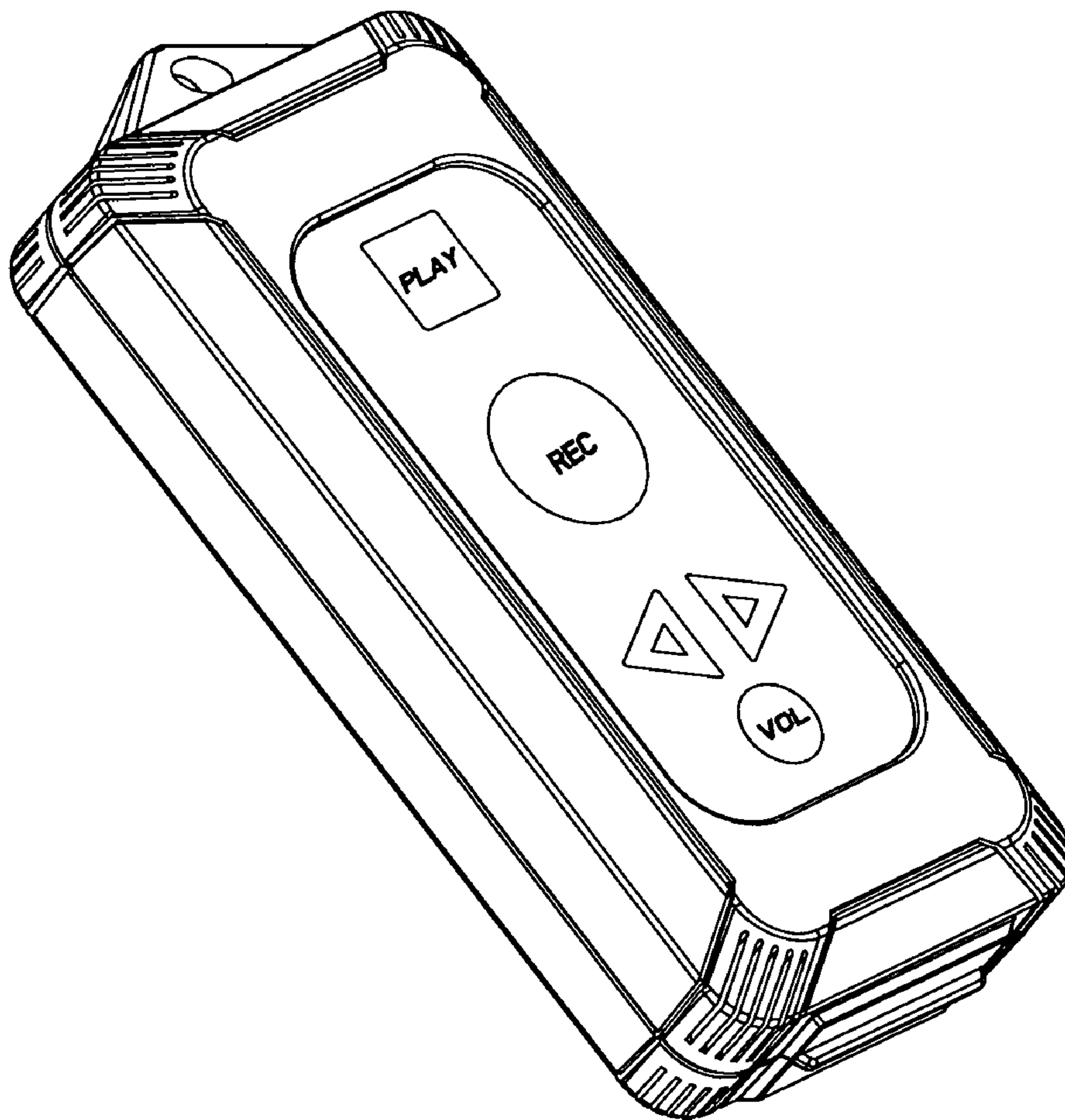

Fig. 2

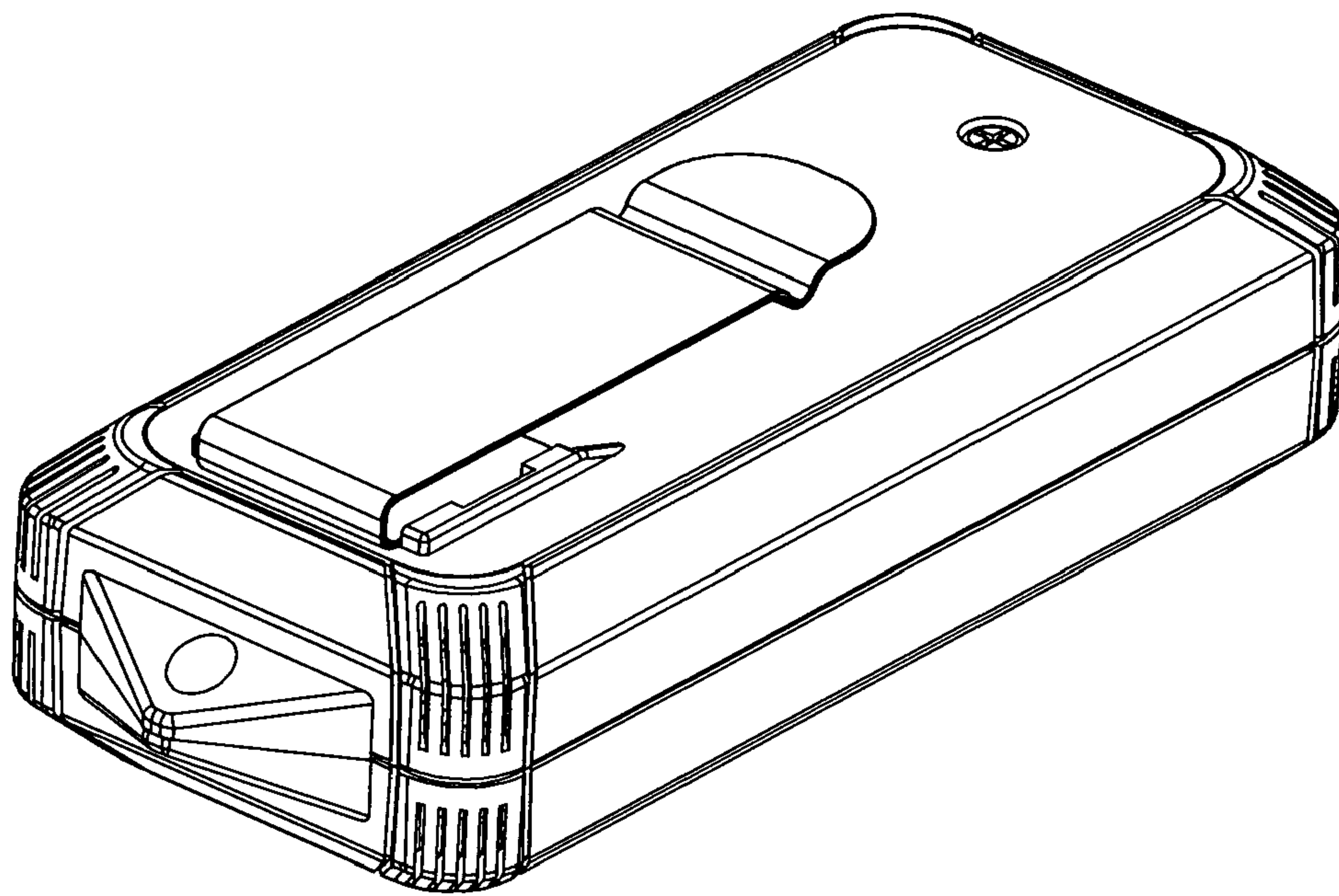

Fig. 3

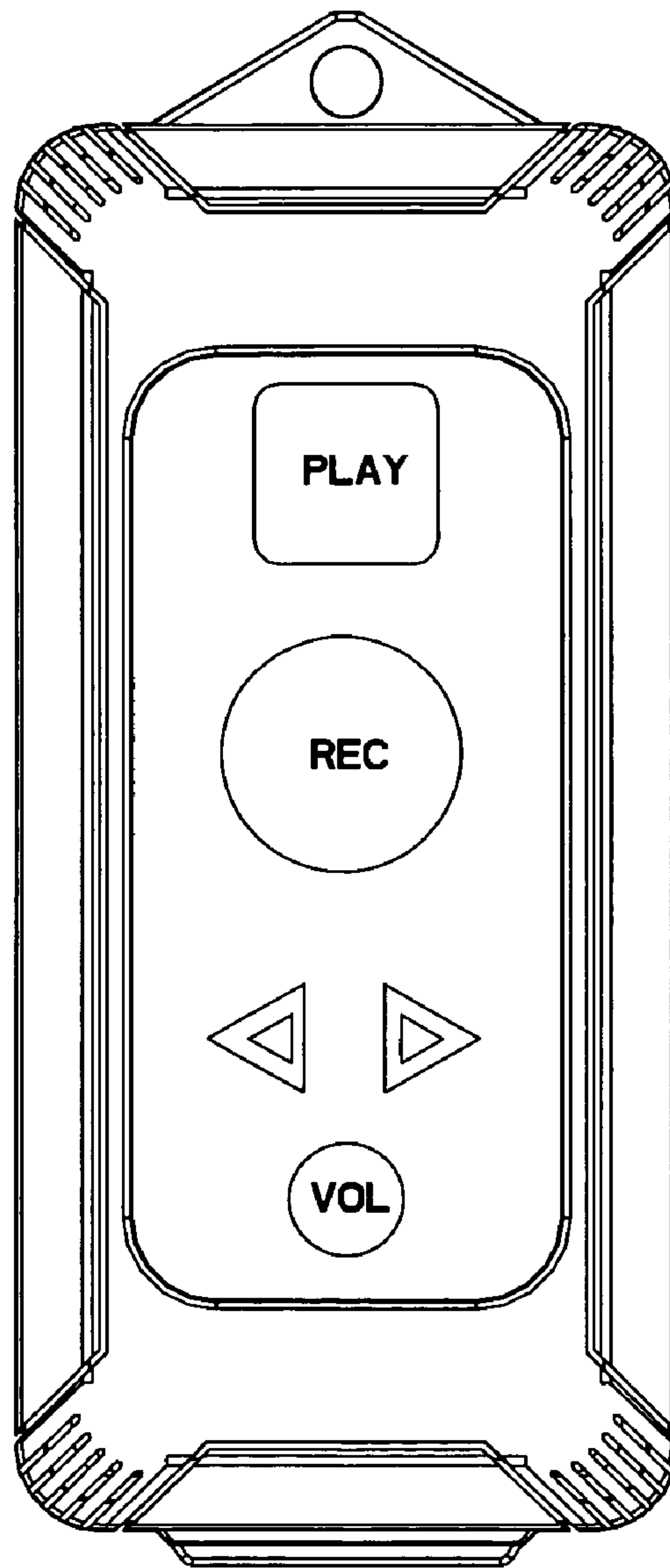

Fig. 4

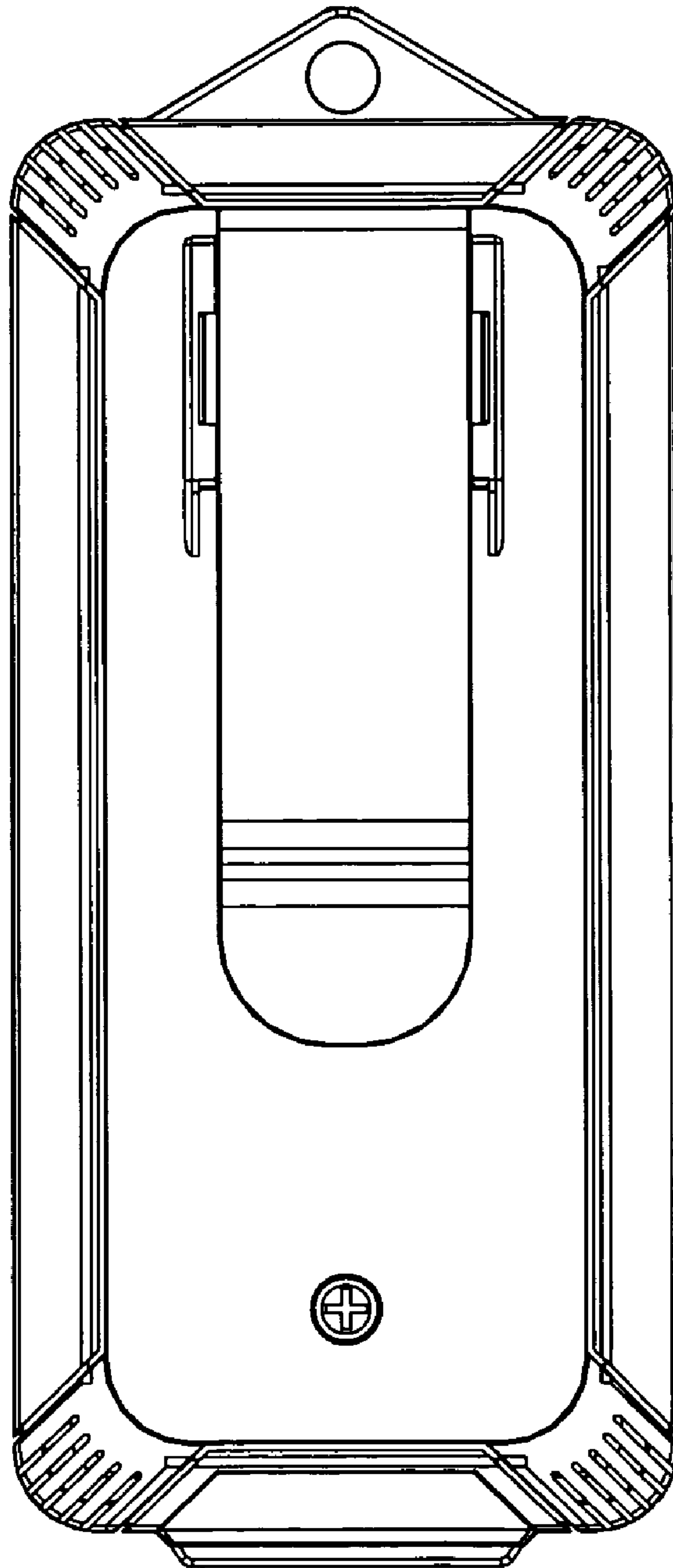

Fig. 5

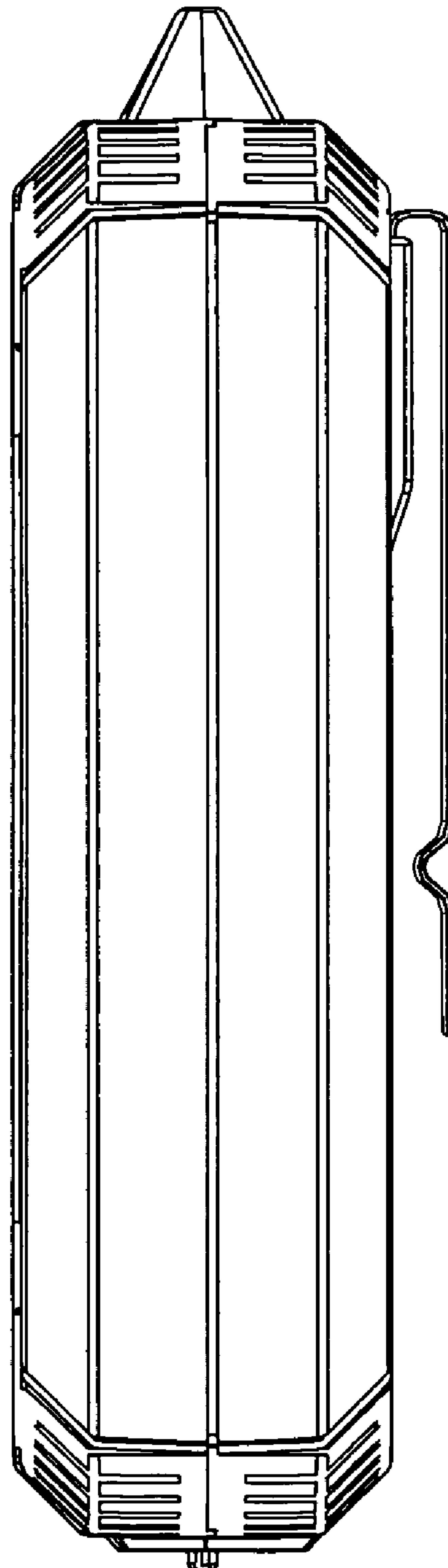

Fig. 6

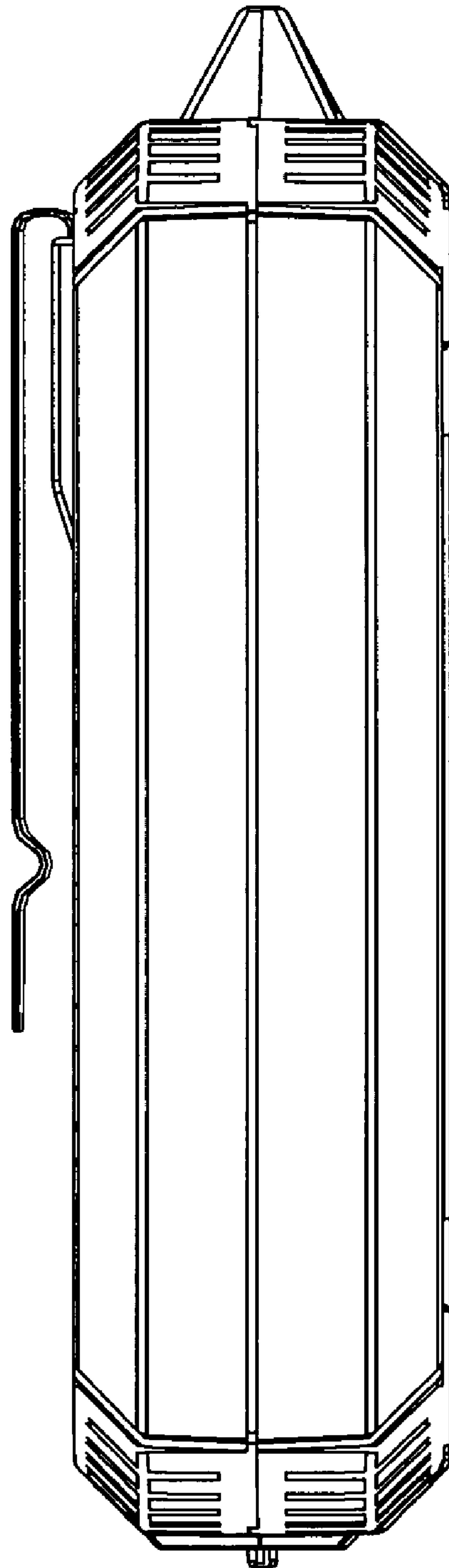

Fig. 7

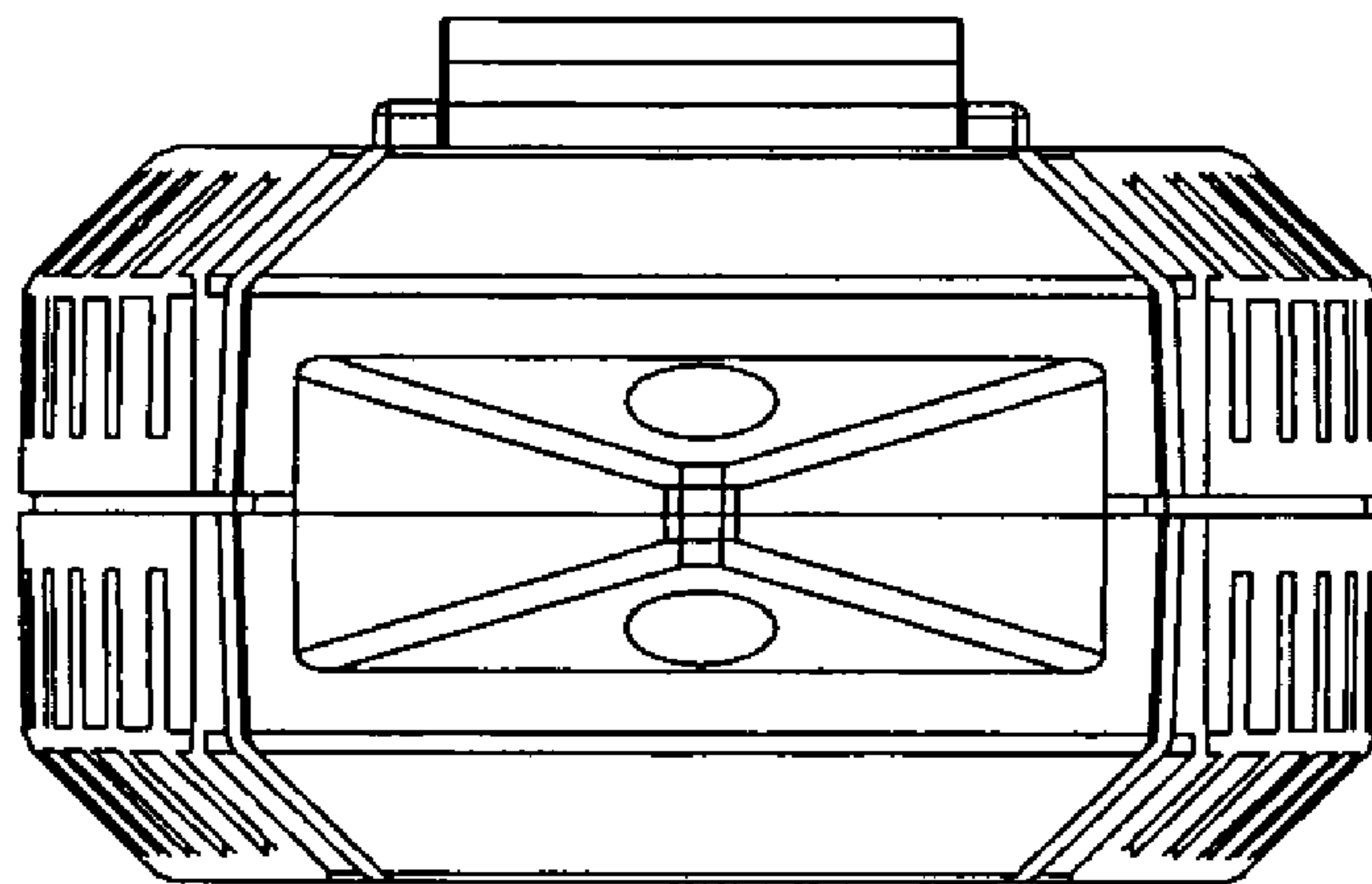

Fig. 8

