



US00D655064S

(12) **United States Design Patent**
Knie

(10) **Patent No.:** **US D655,064 S**

(45) **Date of Patent:** **** Feb. 28, 2012**

(54) **LIFT TRUCK**

(75) **Inventor:** **Andreas Knie**, Hamburg (DE)

(73) **Assignee:** **Jungheinrich Aktiengesellschaft**,
Hamburg (DE)

(**) **Term:** **14 Years**

(21) **Appl. No.:** **29/345,874**

(22) **Filed:** **Oct. 23, 2009**

(30) **Foreign Application Priority Data**

Apr. 27, 2009 (EM) 001128359

(51) **LOC (9) Cl.** **12-05**

(52) **U.S. Cl.** **D34/34**

(58) **Field of Classification Search** D34/34,
D34/35, 28; 180/89.12, 299, 325; 280/43.12;
187/222, 224

See application file for complete search history.

(56) **References Cited**

U.S. PATENT DOCUMENTS

D136,279	S	*	8/1943	Holland et al.	D34/34
2,618,490	A	*	11/1952	Frischmann	280/43.12
3,243,194	A	*	3/1966	Trusock	280/43.12
3,249,170	A	*	5/1966	Quayle	180/19.2
3,261,617	A	*	7/1966	Becker et al.	280/43.12
3,352,569	A	*	11/1967	Goodacre	280/43.12
D222,670	S	*	11/1971	Goodacre	D34/34

D239,165	S	*	3/1976	Mono	D34/34
4,047,698	A	*	9/1977	Ellis	254/2 R
4,615,533	A	*	10/1986	Sewell	280/43.12
D343,935	S	*	2/1994	Drobeck et al.	D34/35
5,590,735	A	*	1/1997	Cartier	180/210
D408,958	S	*	4/1999	Schneider	D34/28
6,125,971	A	*	10/2000	Niebuhr et al.	187/231
D447,612	S	*	9/2001	Niebuhr	D34/34
D464,785	S	*	10/2002	Gallagher	D34/35
D542,004	S	*	5/2007	Righi	D34/34
D559,498	S	*	1/2008	Ruppert et al.	D34/34
D562,525	S	*	2/2008	Graf et al.	D34/34
D565,270	S	*	3/2008	Ruppert et al.	D34/34
2005/0016782	A1	*	1/2005	Gallagher et al.	180/89.12

* cited by examiner

Primary Examiner — Cynthia Ramirez

(74) *Attorney, Agent, or Firm* — Vidas, Arrett & Steinkraus,
P.A.

(57) **CLAIM**

The ornamental design for a lift truck, as shown and described.

DESCRIPTION

FIG. 1 in a perspective view;
FIG. 2 in a front view;
FIG. 3 in a rear view;
FIG. 4 in a side elevational view from the right side;
FIG. 5 in a side elevational view from the left side; and,
FIG. 6 in a top view.

1 Claim, 6 Drawing Sheets

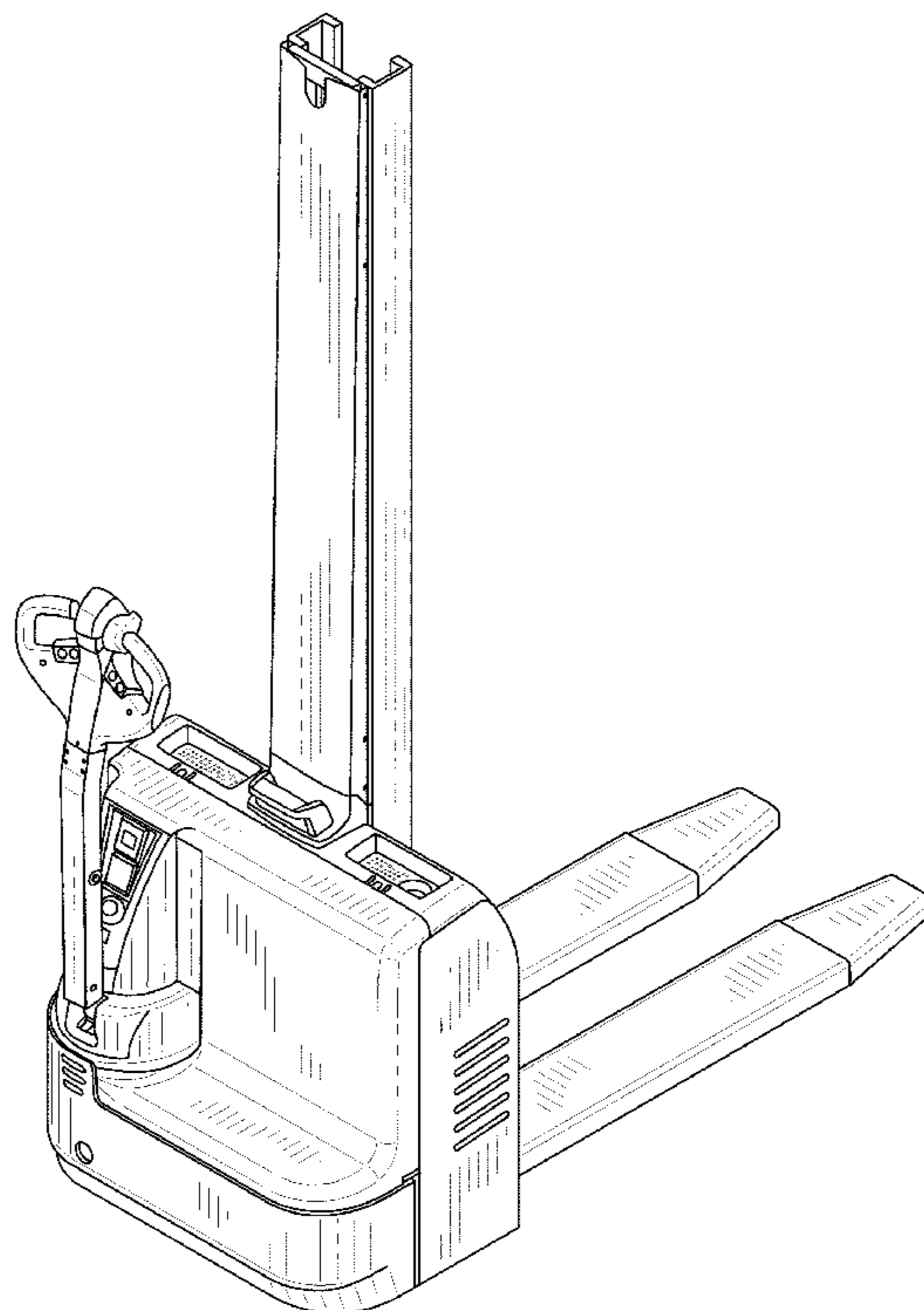

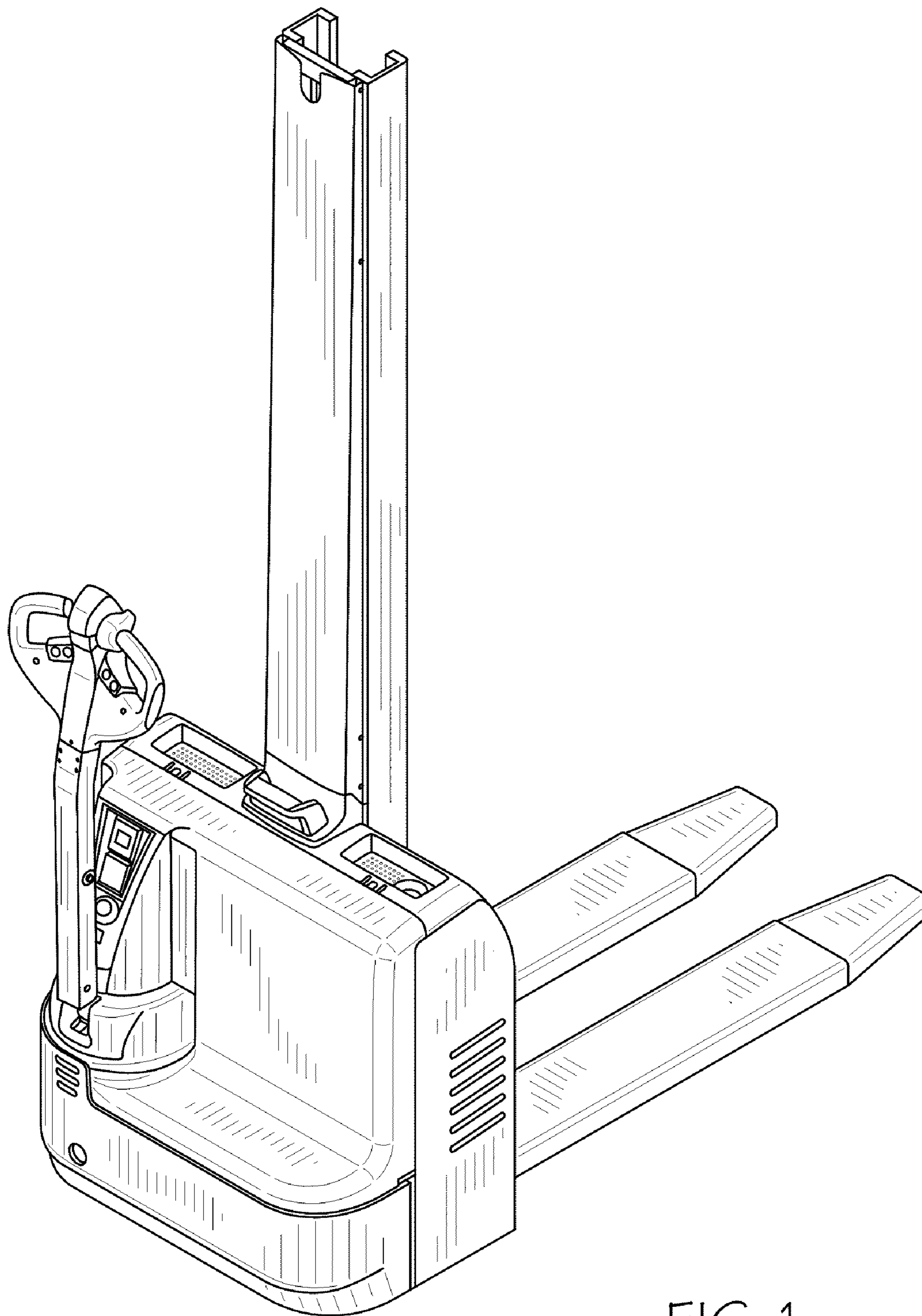

FIG. 1

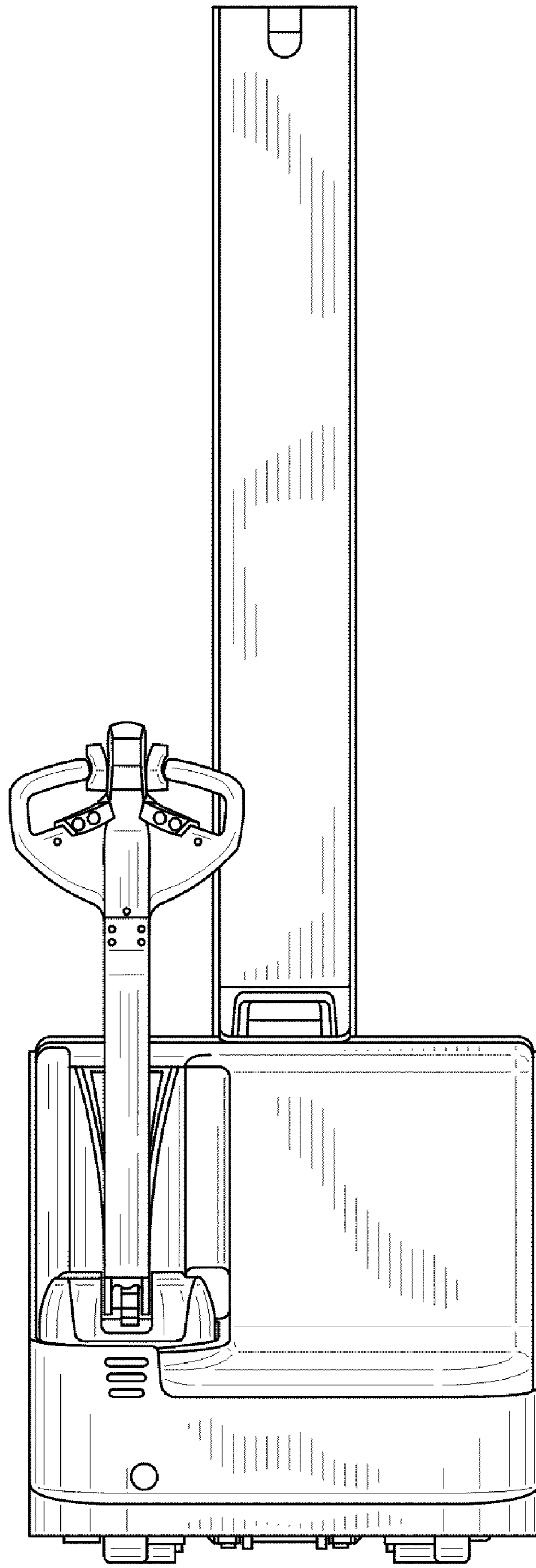

FIG. 2

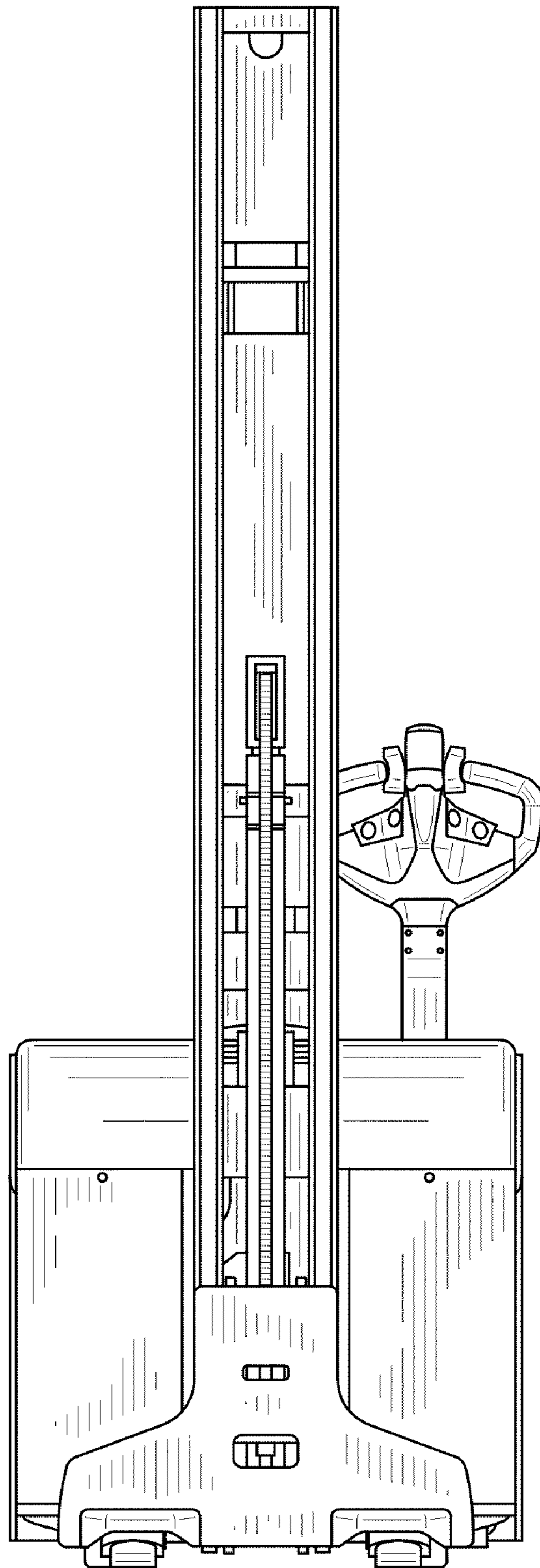

FIG. 3

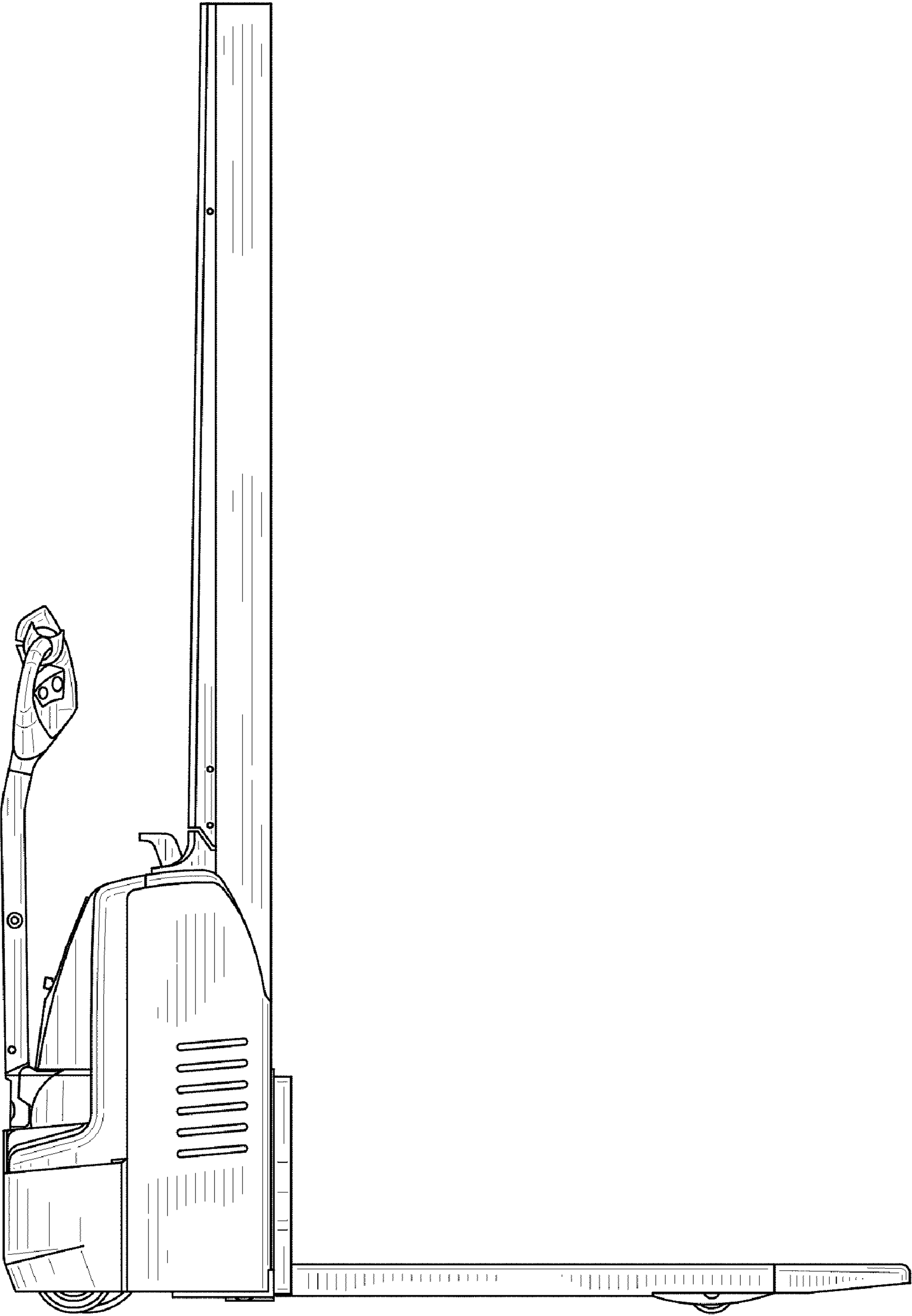

FIG. 4

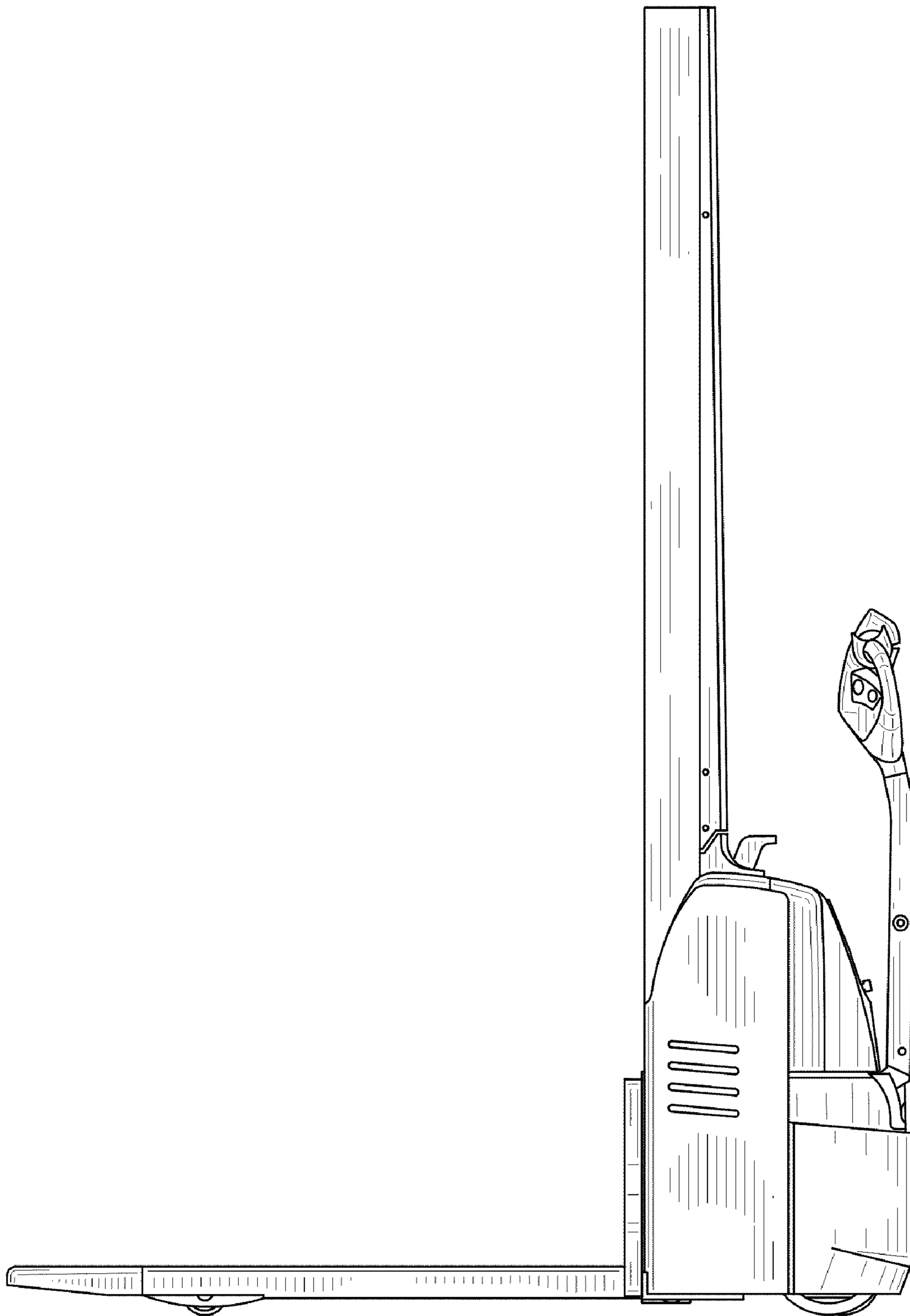

FIG. 5

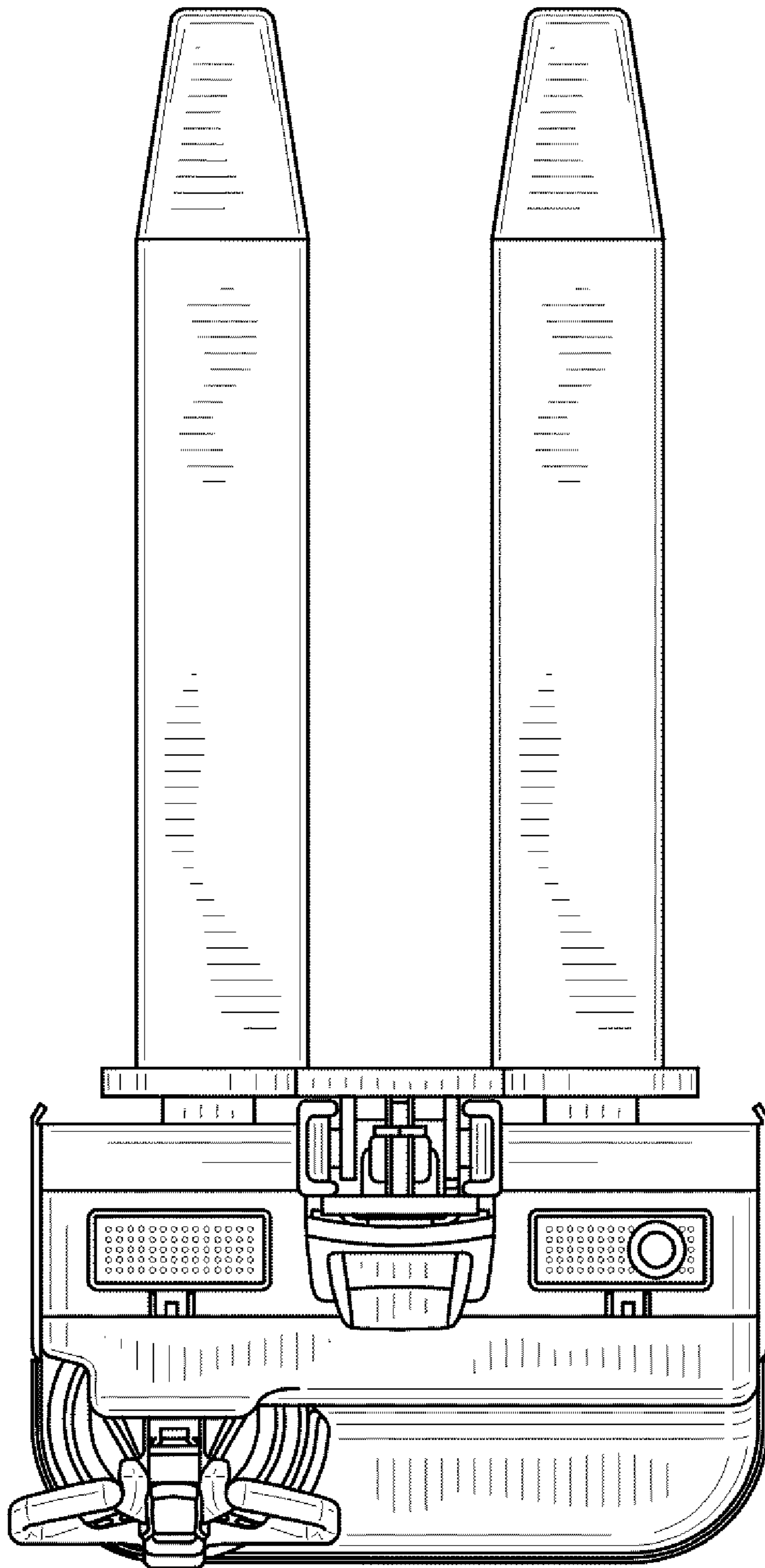

FIG. 6