



US00D654873S

(12) **United States Design Patent**
Au

(10) **Patent No.:** **US D654,873 S**

(45) **Date of Patent:** **** Feb. 28, 2012**

(54) **USB VEHICLE POWER ADAPTER**

(75) Inventor: **Ka Hung Au**, Hong Kong (CN)

(73) Assignee: **Ever Win International Corporation**,
City of Industry, CA (US)

(**) Term: **14 Years**

(21) Appl. No.: **29/399,912**

(22) Filed: **Aug. 19, 2011**

(51) **LOC (9) Cl.** **13-03**

(52) **U.S. Cl.** **D13/144**

(58) **Field of Classification Search** D13/107,
D13/108, 110, 118, 119, 120, 133, 144, 154,
D13/184, 199; 320/107-109; 363/13, 146;
439/300, 620.01, 638, 668-670, 675, 825
See application file for complete search history.

(56) **References Cited**

U.S. PATENT DOCUMENTS

D621,783 S	*	8/2010	Riede	D13/144
D624,499 S	*	9/2010	Chan	D13/144
D624,500 S	*	9/2010	Chan	D13/144
D624,501 S	*	9/2010	Chan	D13/144
D624,879 S	*	10/2010	Chan	D13/144

D625,690 S	*	10/2010	Chan	D13/144
D626,072 S	*	10/2010	Tseng et al.	D13/144
D626,507 S	*	11/2010	Riede	D13/144

* cited by examiner

Primary Examiner — Daniel Bui

(74) *Attorney, Agent, or Firm* — Joe Nieh

(57) **CLAIM**

The ornamental design for a USB vehicle power adapter, as shown and described.

DESCRIPTION

FIG. 1 is a top, front and right side perspective view of a USB vehicle power adapter showing my new design;
FIG. 2 is a top, rear, and left side perspective view thereof;
FIG. 3 is a top plan view thereof,
FIG. 4 is a front elevation view thereof,
FIG. 5 is a rear elevation view thereof;
FIG. 6 is a left side elevation view thereof;
FIG. 7 is a right side elevation view thereof; and,
FIG. 8 is a bottom plan view thereof.

The broken line shown in the drawing views is included for the purpose of illustrating environment and forms no part of the claimed design.

1 Claim, 8 Drawing Sheets

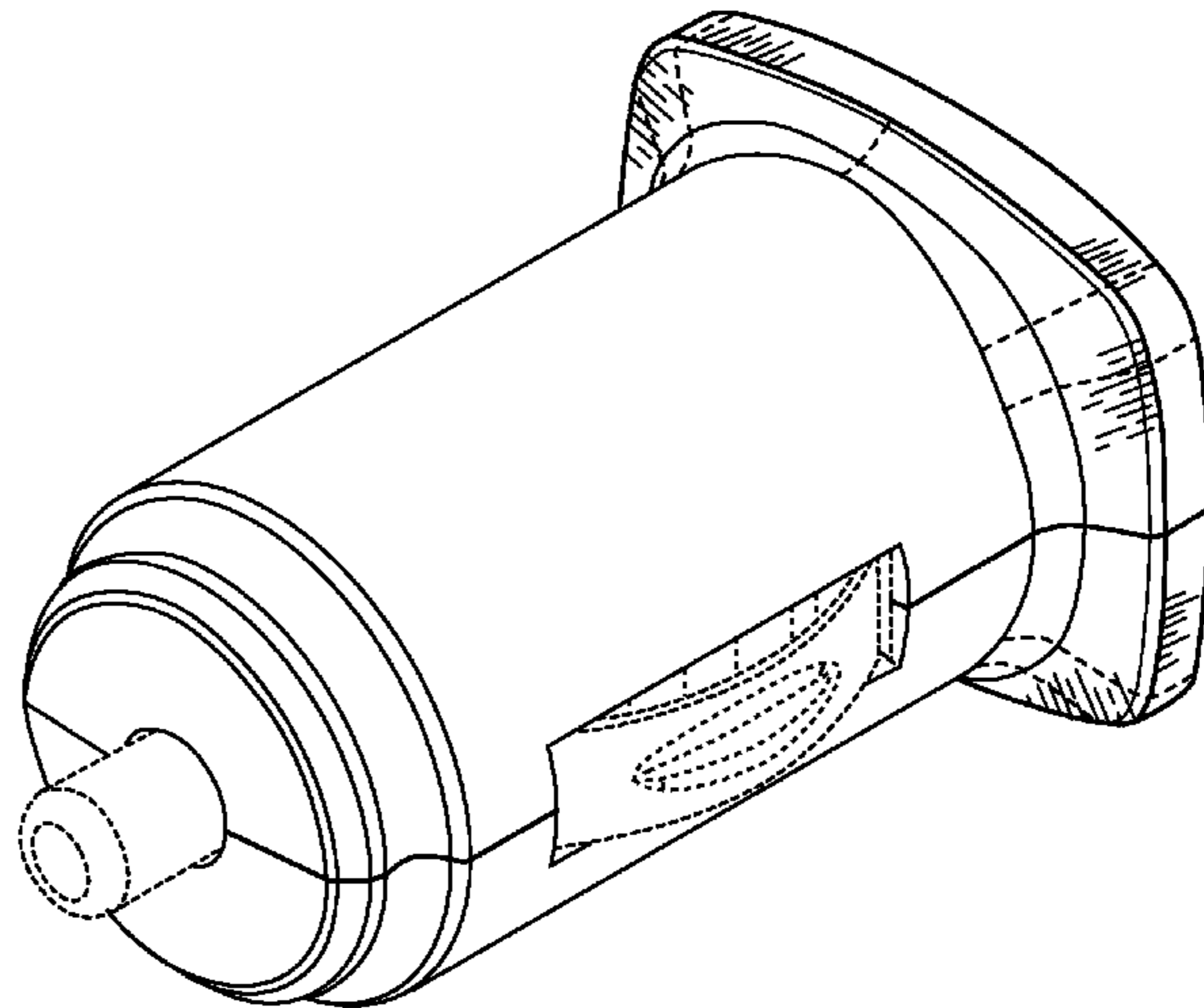
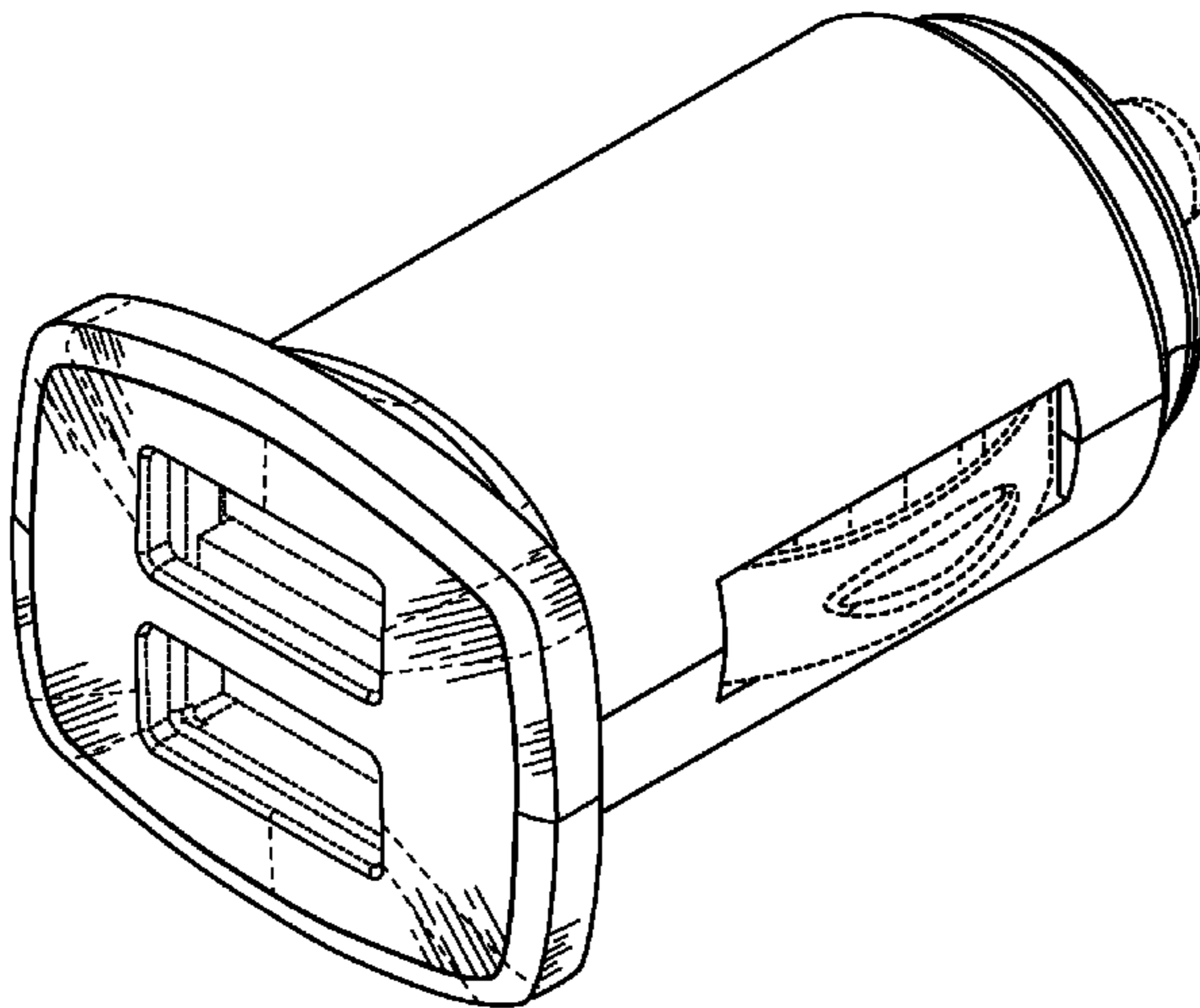

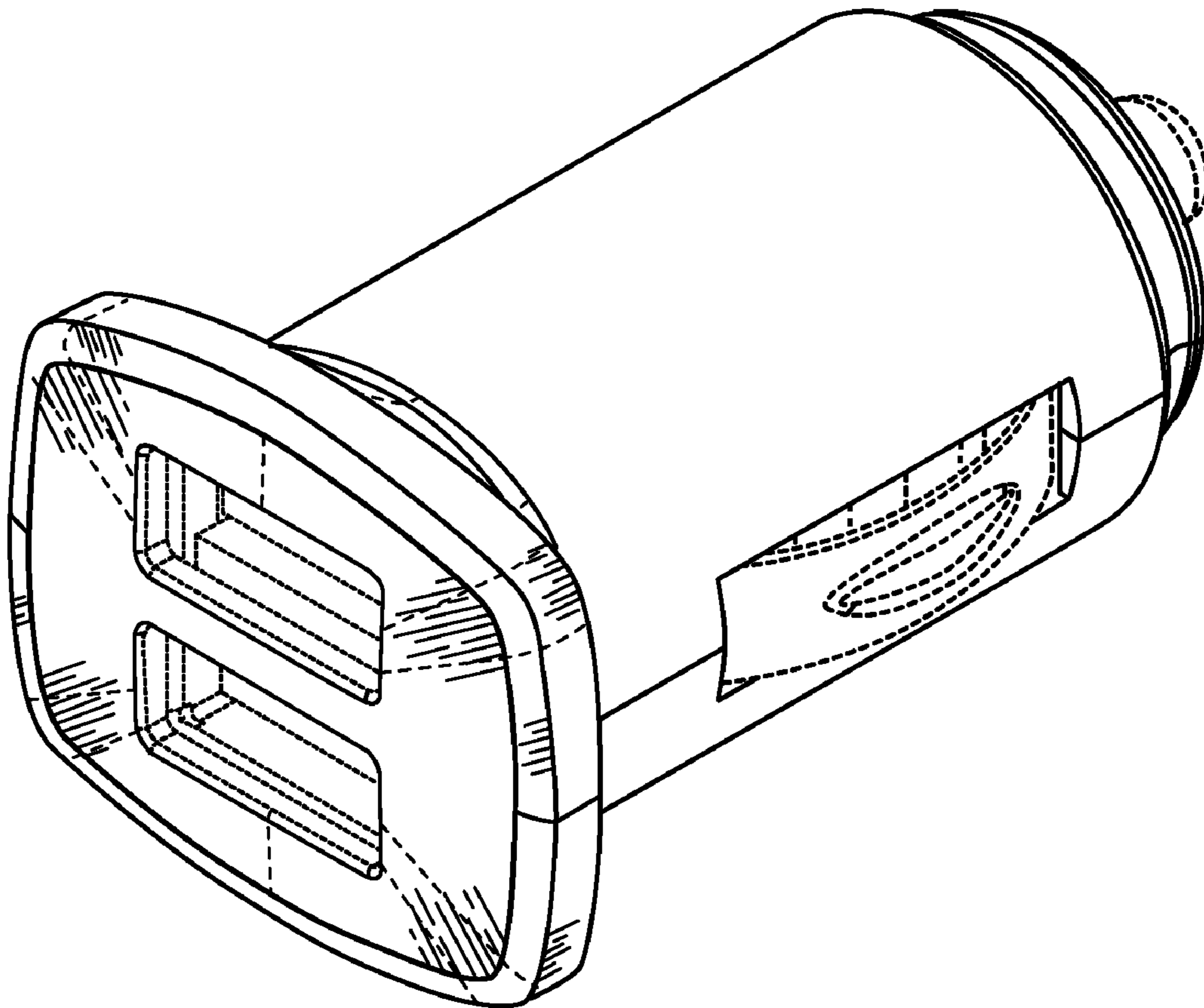

Fig. 1

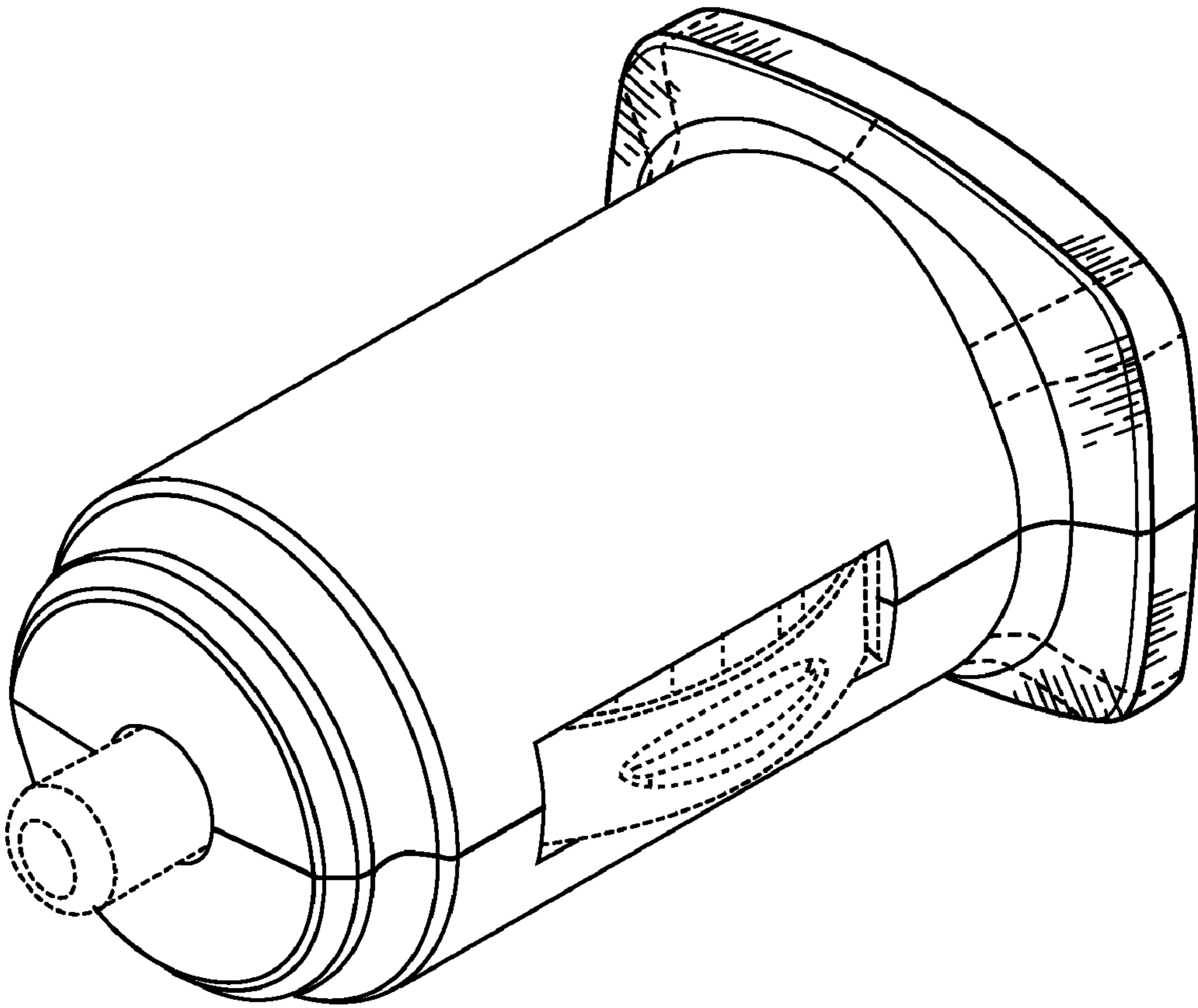

Fig. 2

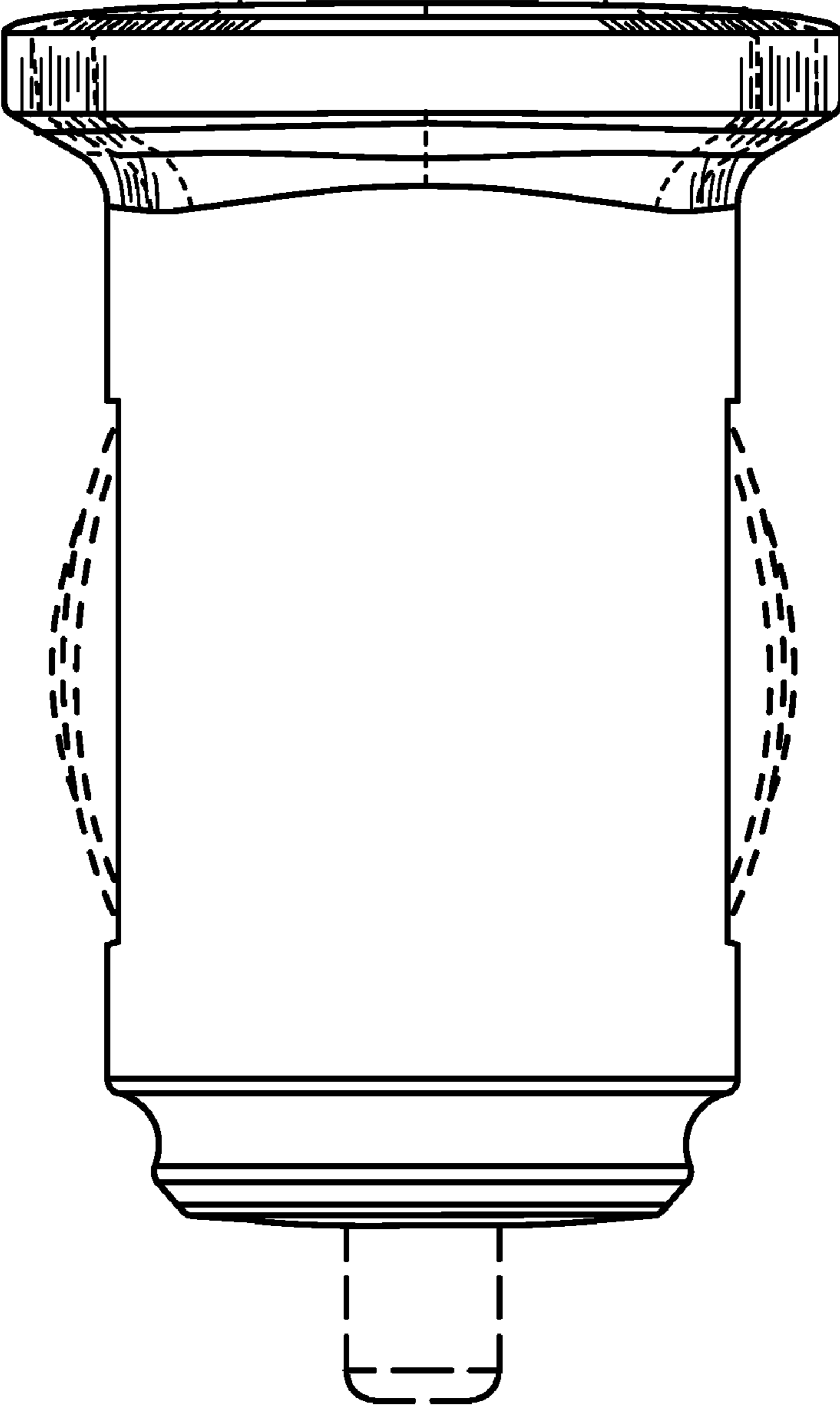

Fig. 3

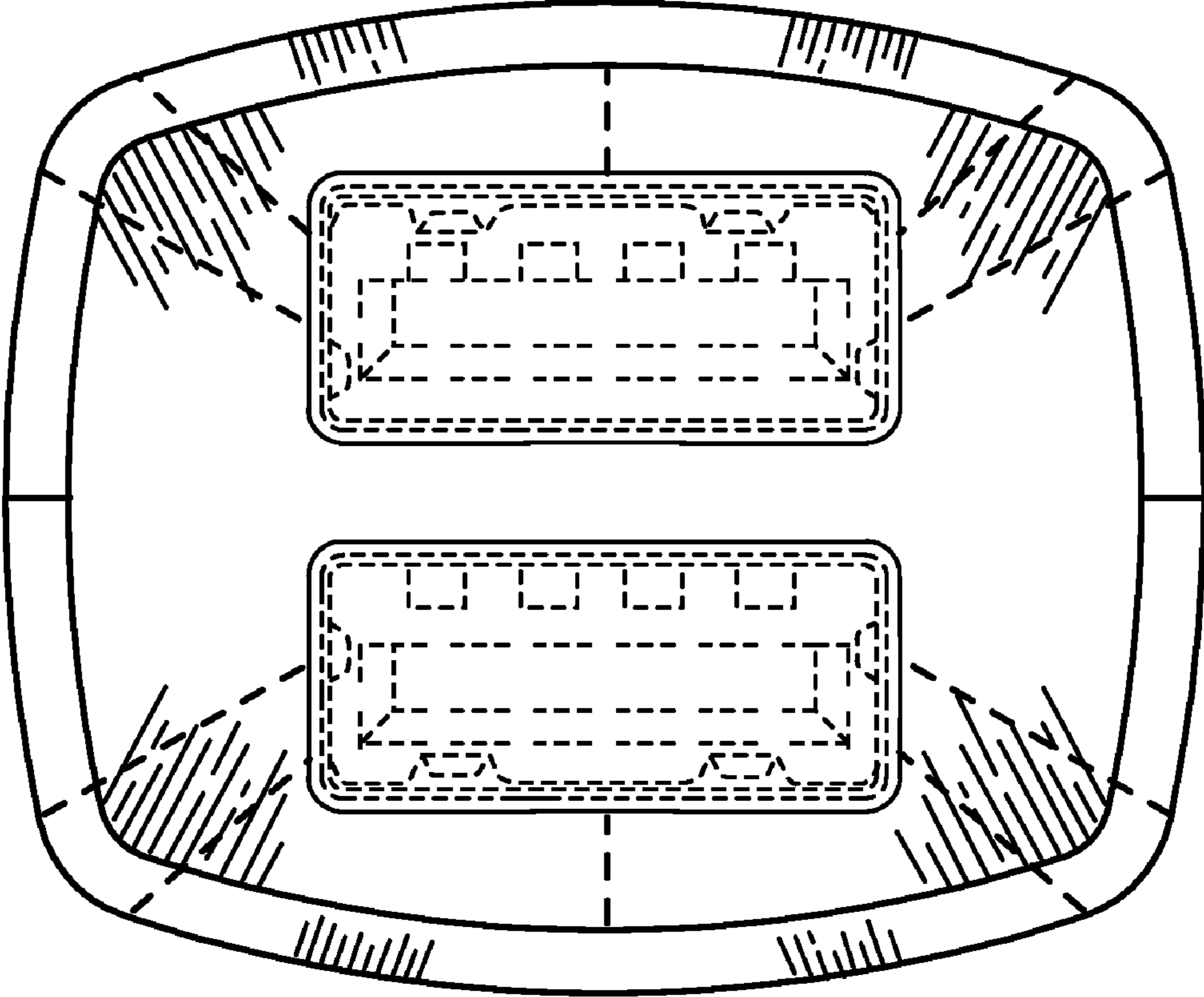

Fig. 4

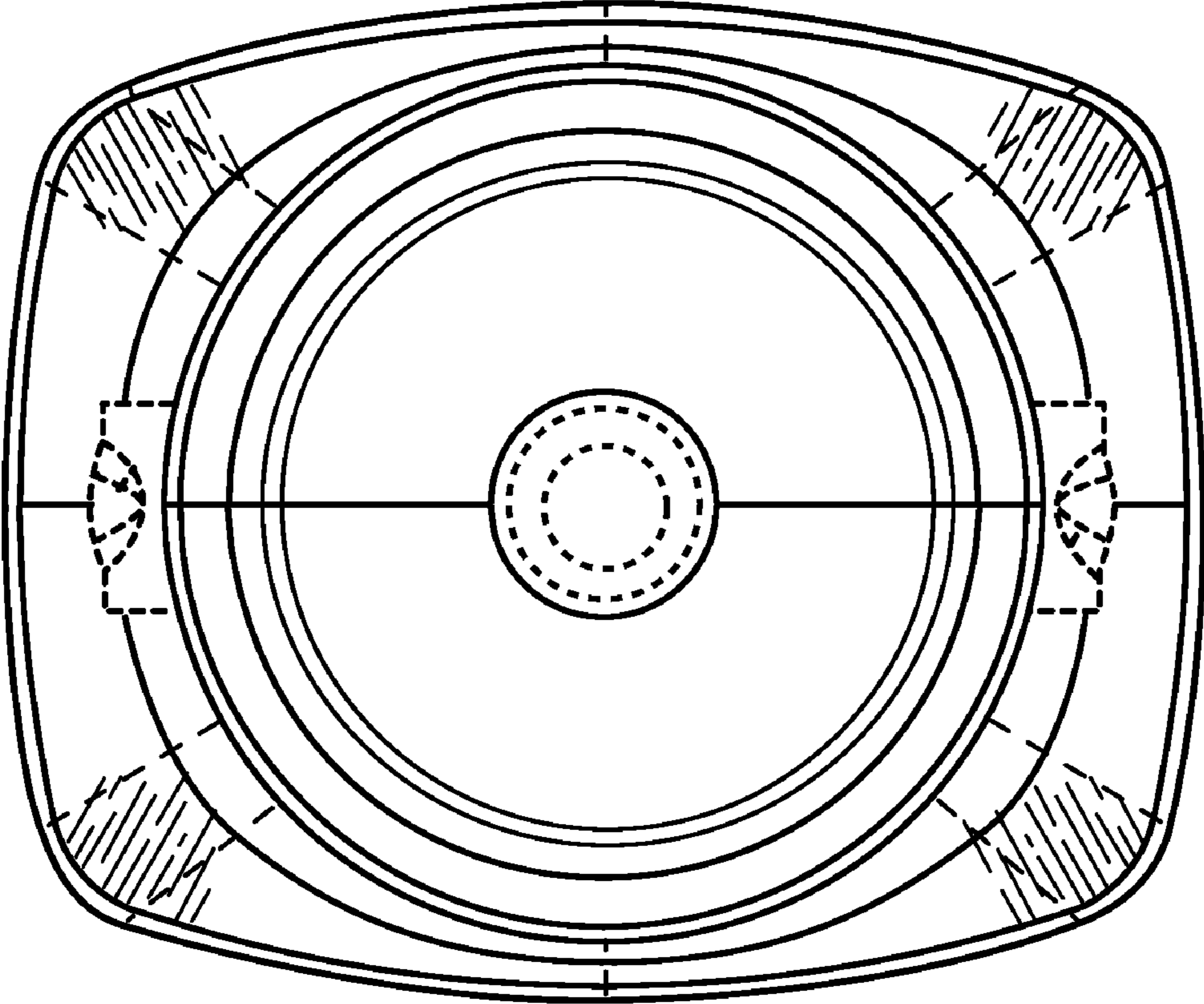

Fig. 5

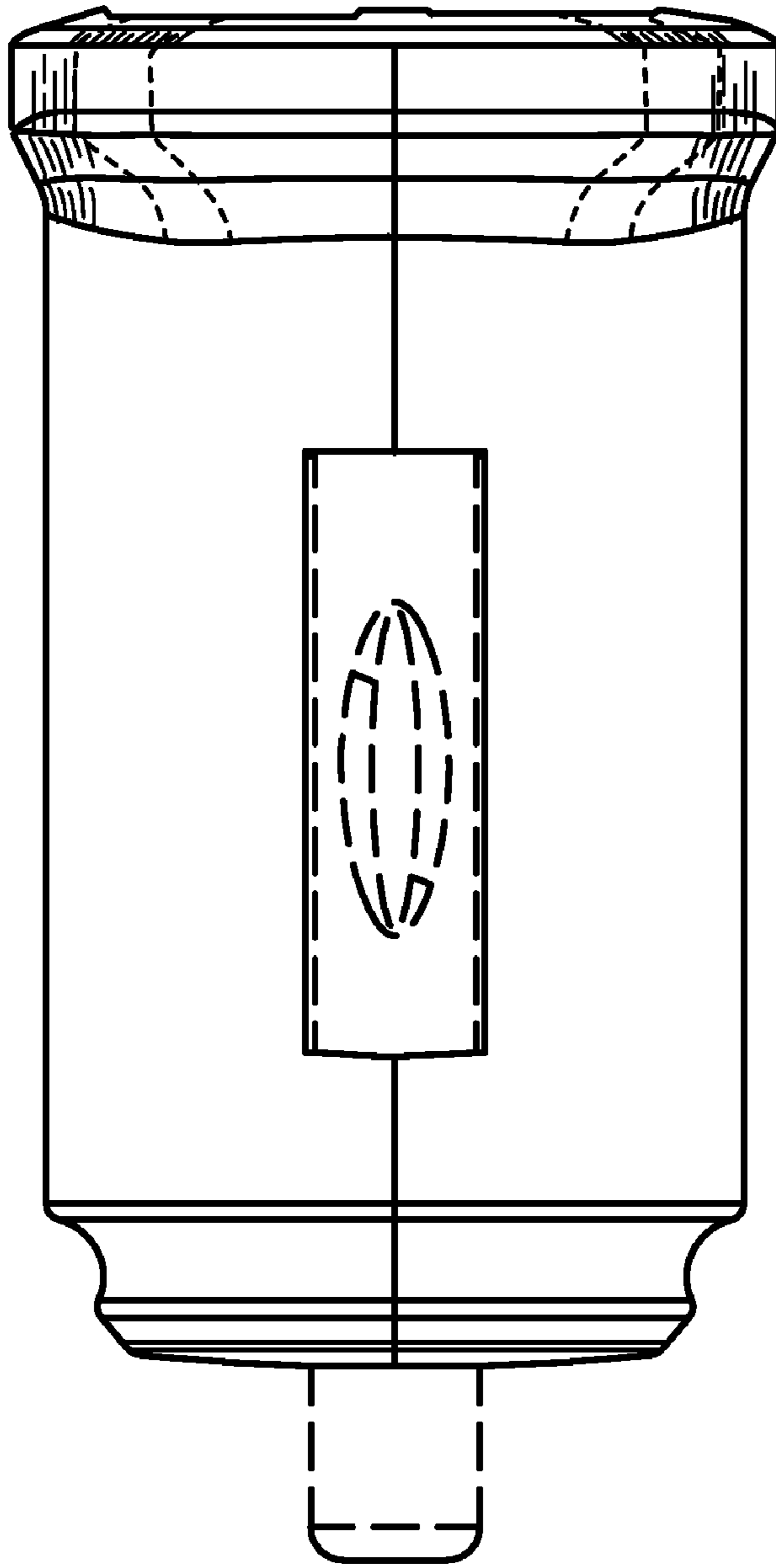

Fig. 6

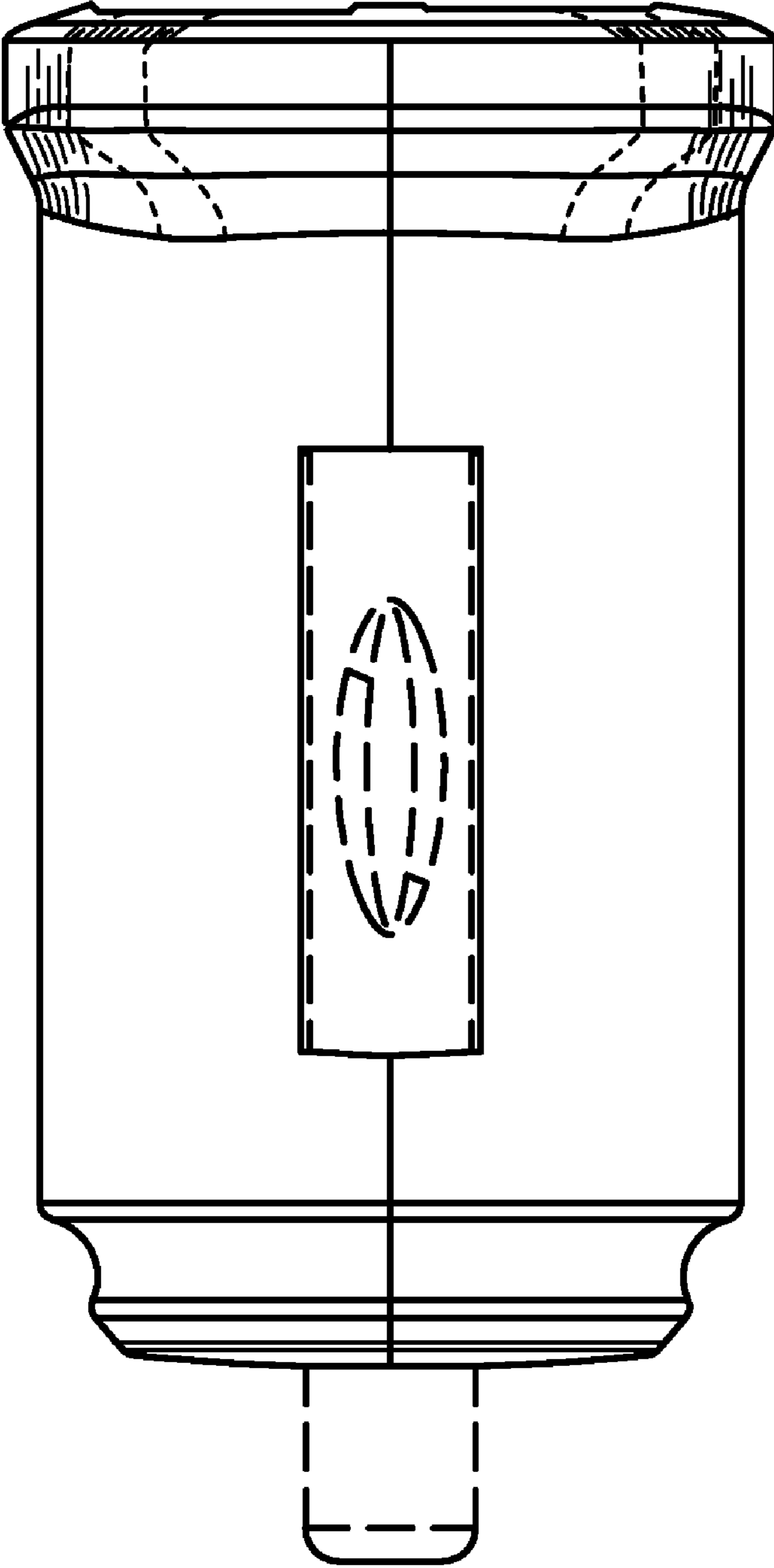

Fig. 7

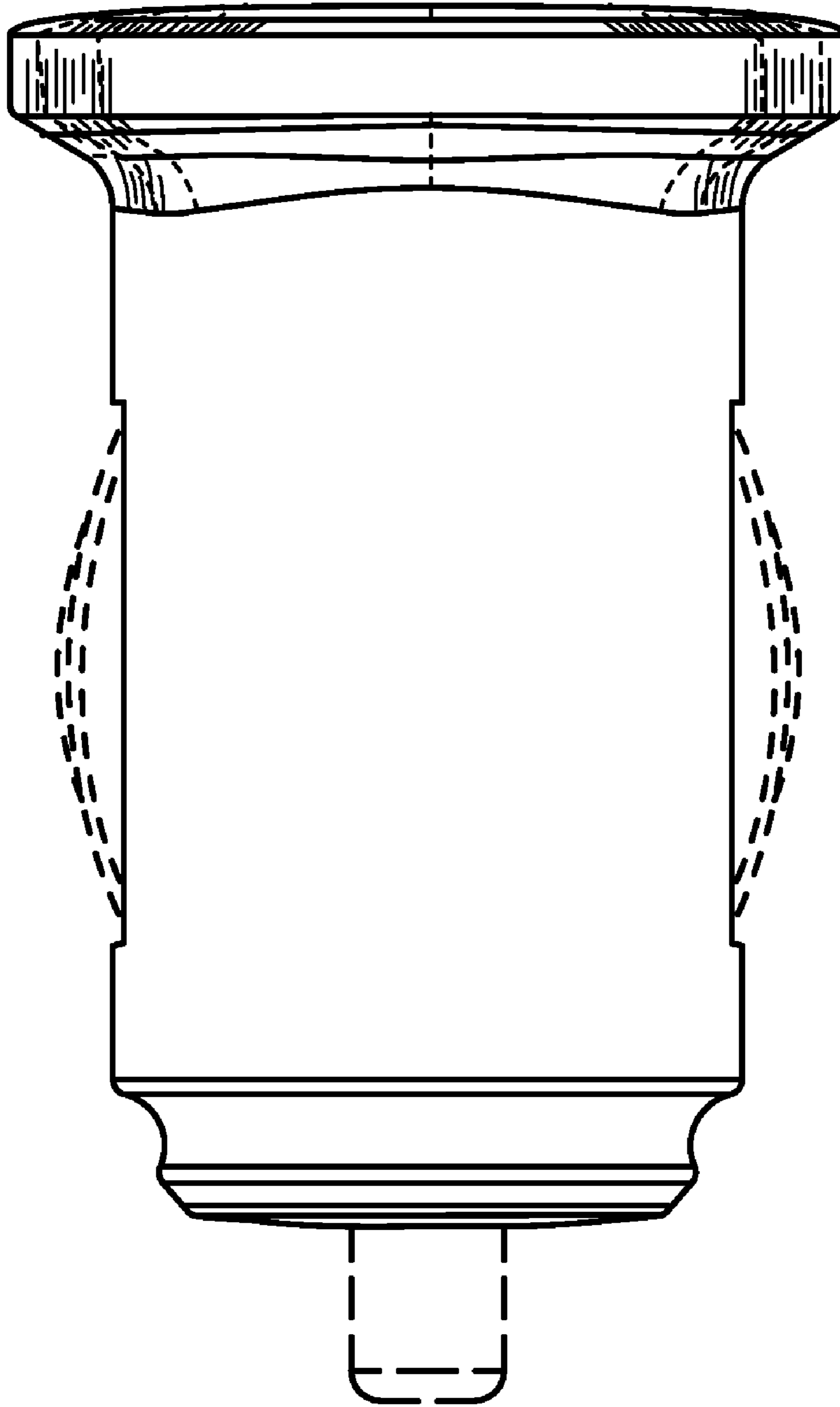

Fig. 8