



US00D654775S

(12) **United States Design Patent**  
**Higashi**

(10) **Patent No.:** **US D654,775 S**

(45) **Date of Patent:** **\*\* Feb. 28, 2012**

(54) **HANDLE GRIP FOR TWO-WHEELED MOTOR VEHICLE**

(75) Inventor: **Yumiko Higashi, Niiza (JP)**

(73) Assignee: **Honda Motor Co., Ltd. (JP)**

(\*\*) Term: **14 Years**

(21) Appl. No.: **29/356,135**

(22) Filed: **Feb. 19, 2010**

(30) **Foreign Application Priority Data**

Sep. 29, 2009 (JP) ..... 2009-022470

(51) **LOC (9) Cl.** ..... **12-11**

(52) **U.S. Cl.** ..... **D8/303**

(58) **Field of Classification Search** ..... D8/303,  
D8/300, 70; D12/110, 111, 178; 16/110.1,  
16/421, 430, 111.1, DIG. 12; 74/488, 489,  
74/502.2, 551.1-551.9, 557; 180/219, 220;  
219/201, 202, 204, 494, 497, 504, 506, 530,  
219/540, 544

See application file for complete search history.

(56) **References Cited**

**U.S. PATENT DOCUMENTS**

4,471,209 A \* 9/1984 Hollander ..... 219/204  
D429,990 S \* 8/2000 Kunkler ..... D8/303  
6,844,524 B2 \* 1/2005 Downey et al. .... 219/204  
6,984,807 B2 \* 1/2006 Richlen ..... 219/204

D520,849 S \* 5/2006 Mentasti ..... D8/303  
7,064,292 B1 \* 6/2006 Oishi et al. .... 219/204  
D533,813 S \* 12/2006 Fujiwara et al. .... D12/114  
D534,413 S \* 1/2007 Higashi ..... D8/303  
7,189,943 B2 \* 3/2007 Richlen ..... 219/204  
7,671,299 B2 \* 3/2010 Gifford et al. .... 219/204

**FOREIGN PATENT DOCUMENTS**

JP D1269328 3/2006  
JP D1269329 3/2006

\* cited by examiner

*Primary Examiner* — Susan M Lee

*Assistant Examiner* — Linda G. Brooks

(74) *Attorney, Agent, or Firm* — Akerman Senterfitt

(57) **CLAIM**

The ornamental design for a handle grip for two-wheeled motor vehicle, as shown and described.

**DESCRIPTION**

FIG. 1 is a front perspective view from above of a handle grip for two-wheeled motor vehicle, showing my new design, which includes a switch for actuating an inner grip heater and a handle grip;

FIG. 2 is a front view thereof;

FIG. 3 is a rear view thereof;

FIG. 4 is a top plan view thereof;

FIG. 5 is a bottom plan view thereof;

FIG. 6 is a left side view thereof; and,

FIG. 7 is a right side view thereof.

**1 Claim, 4 Drawing Sheets**

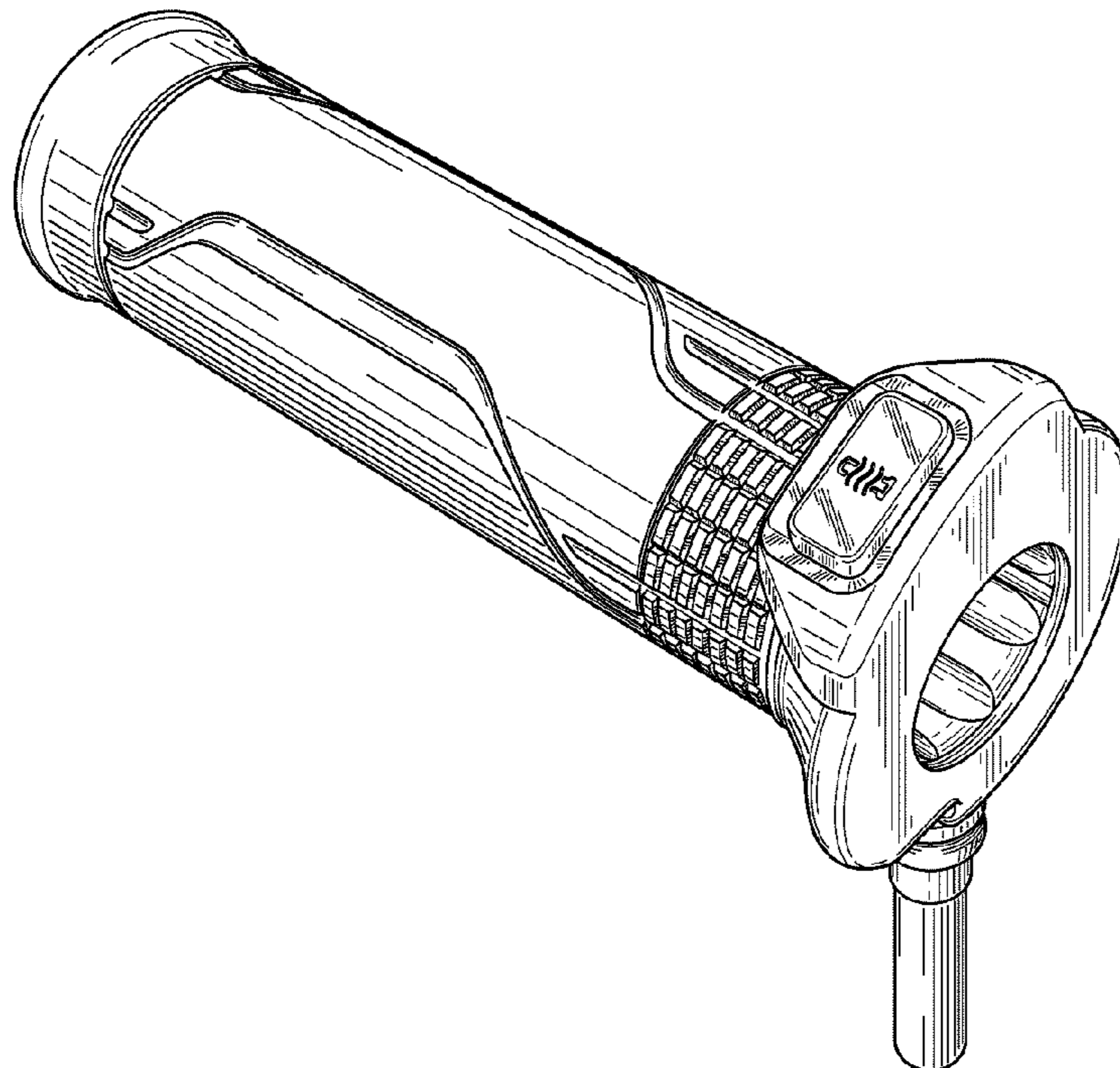

FIG.1

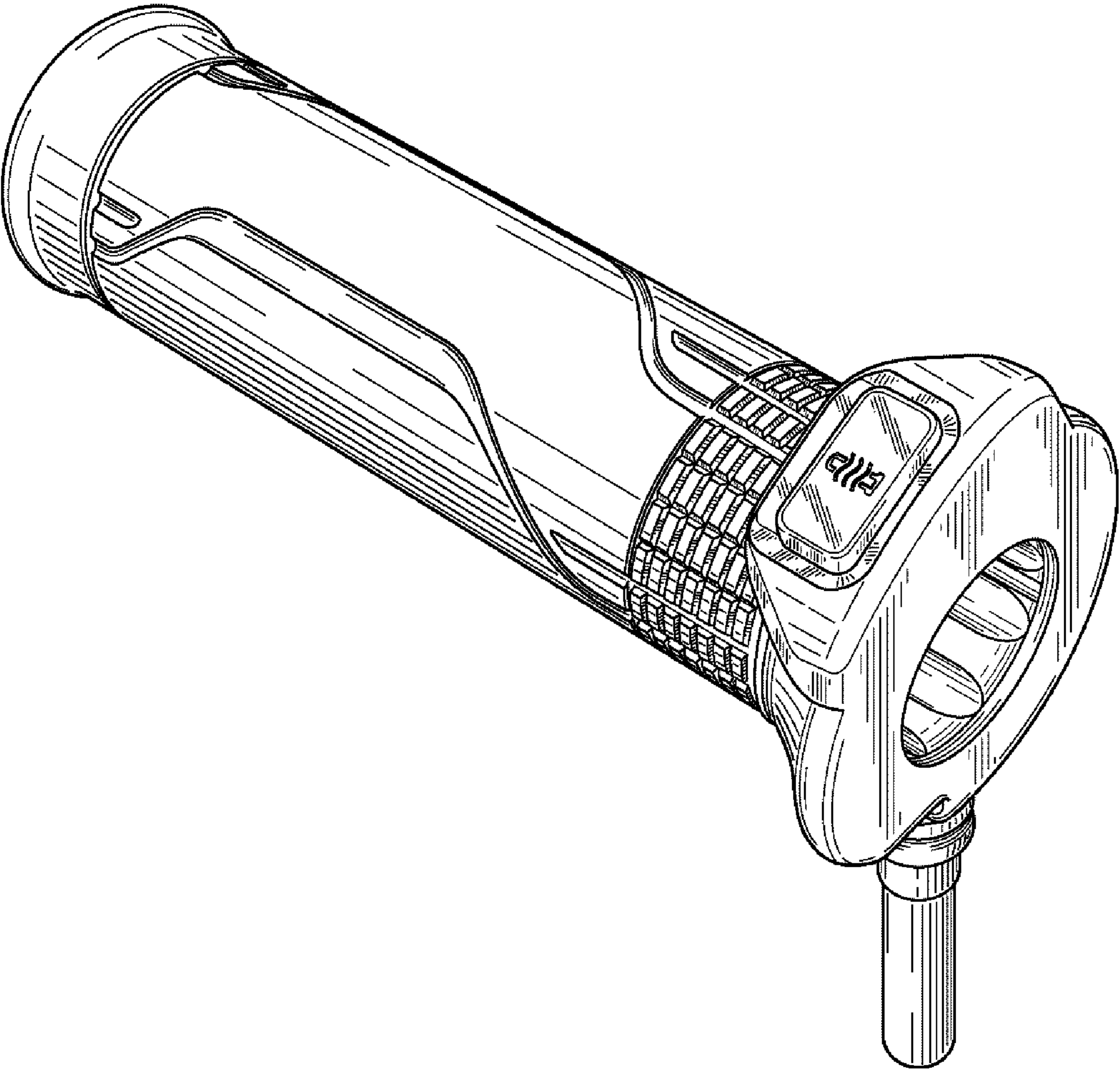

FIG.2

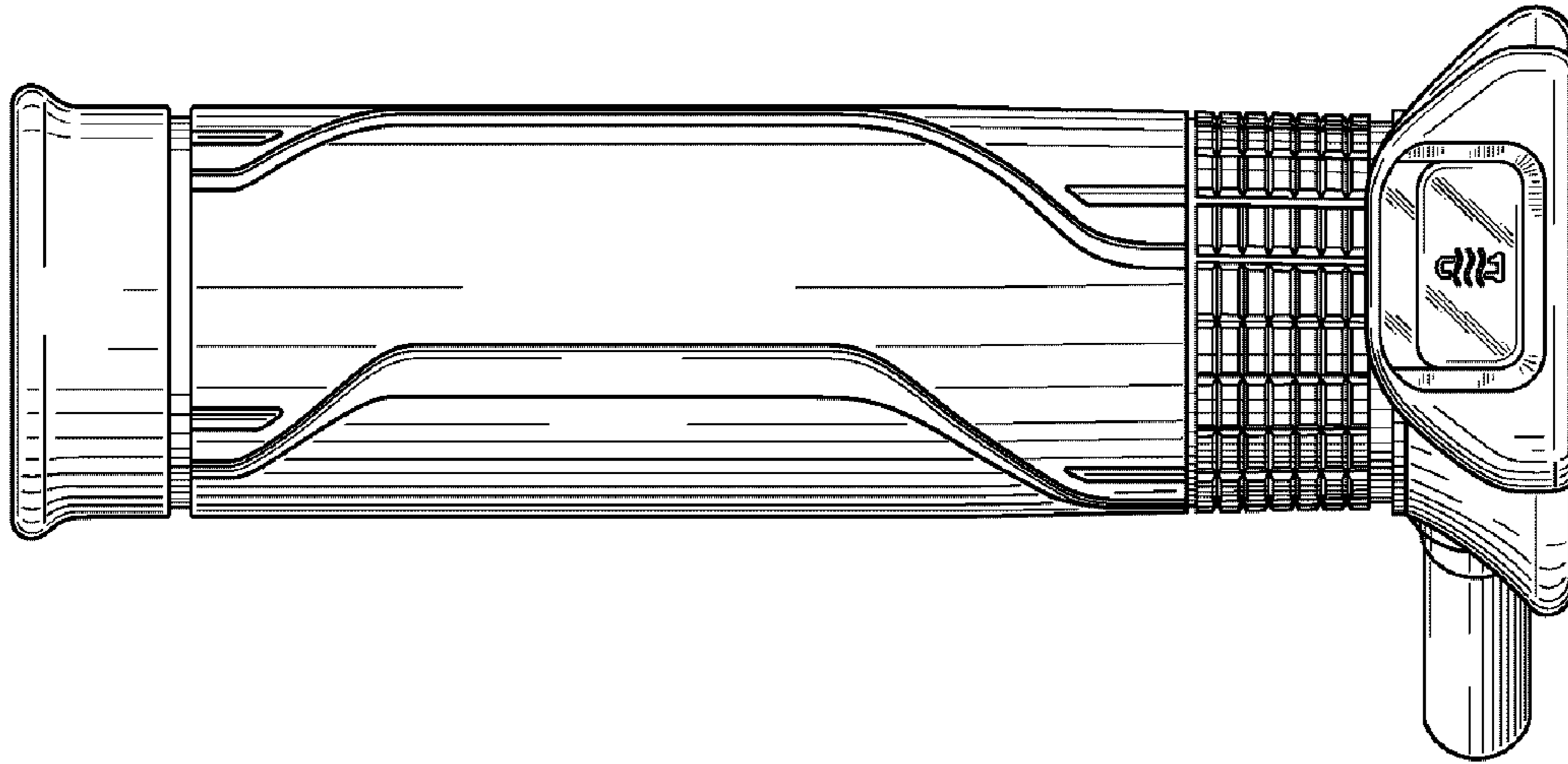

FIG.3

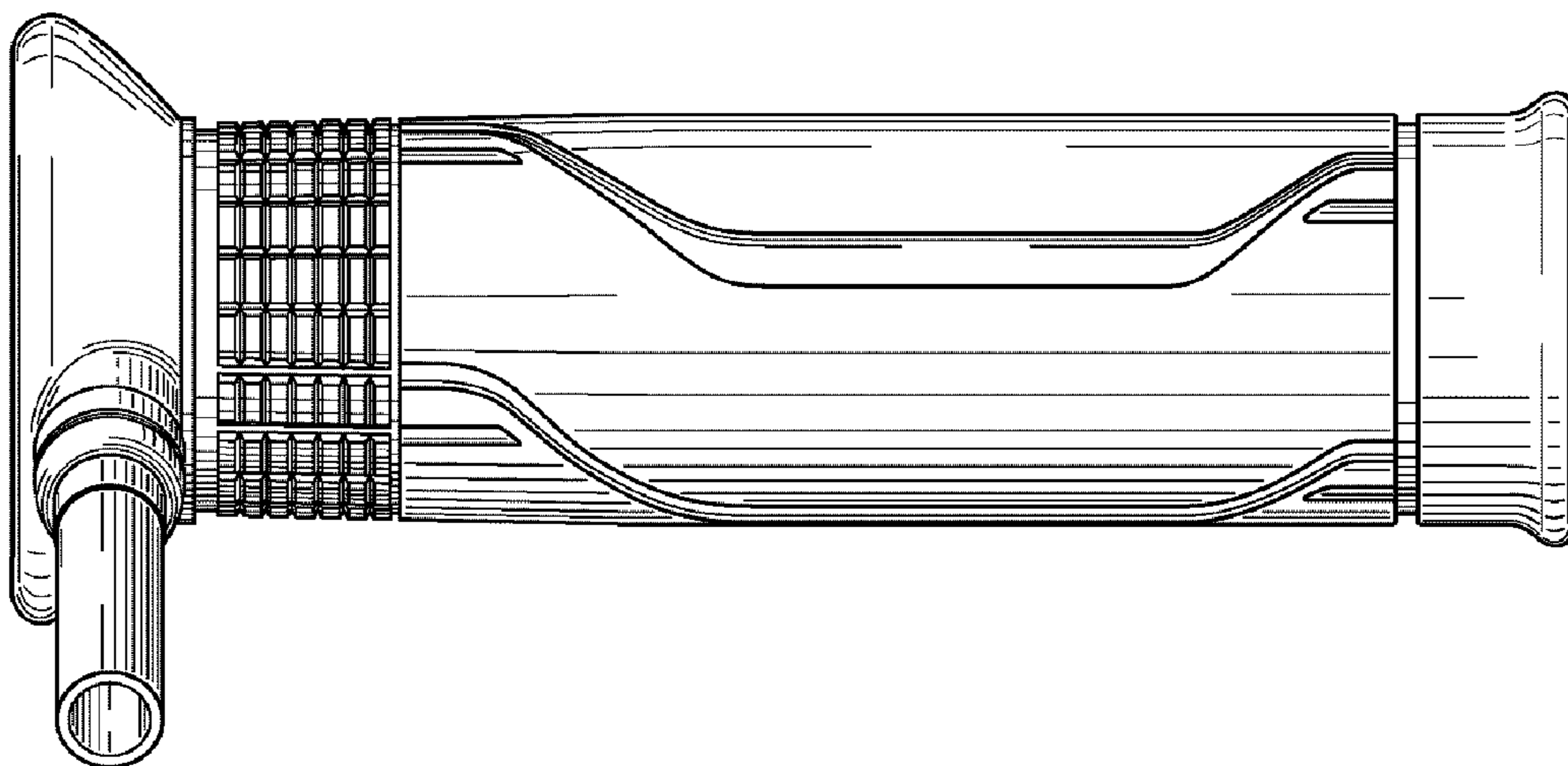

FIG.4

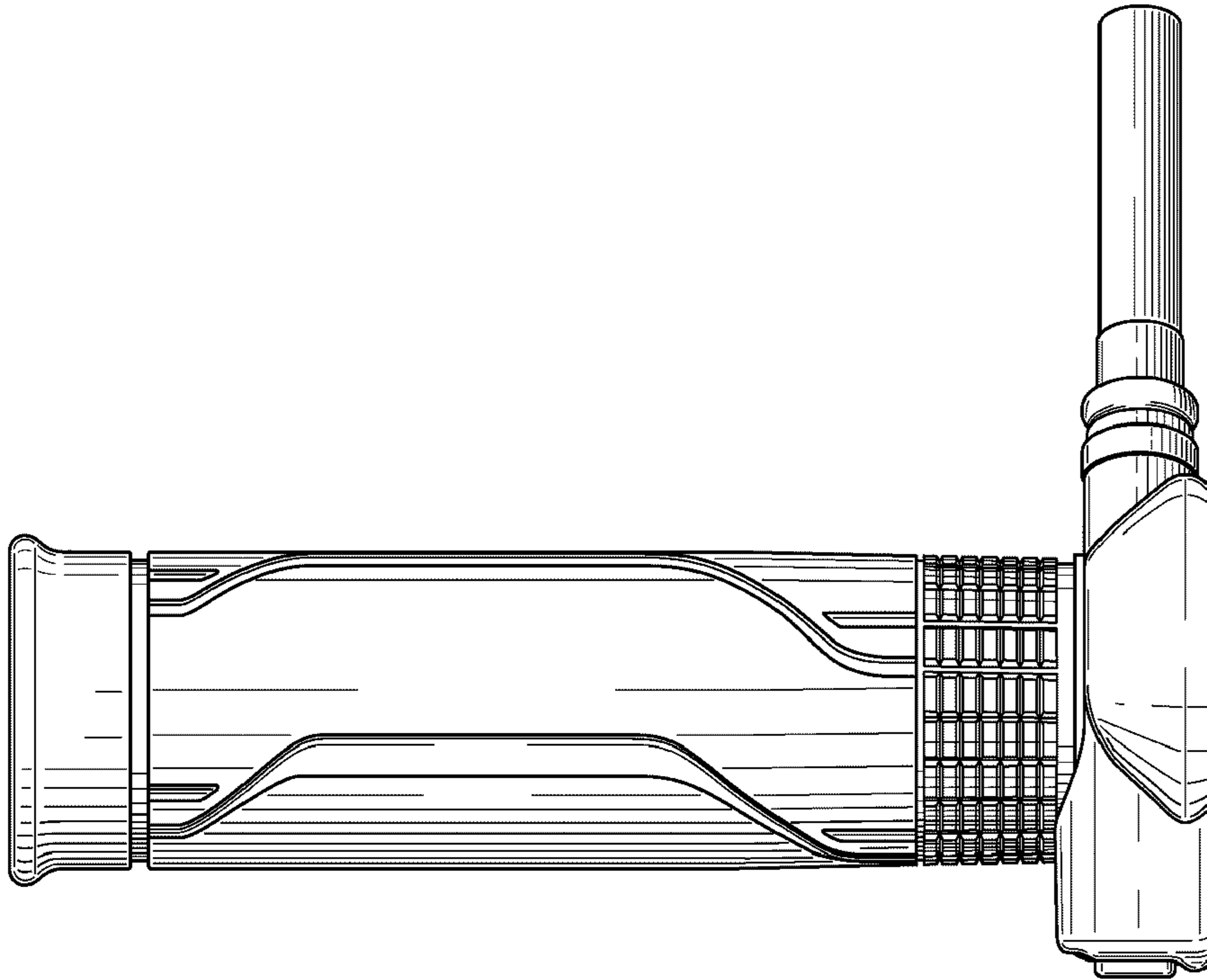

FIG.5

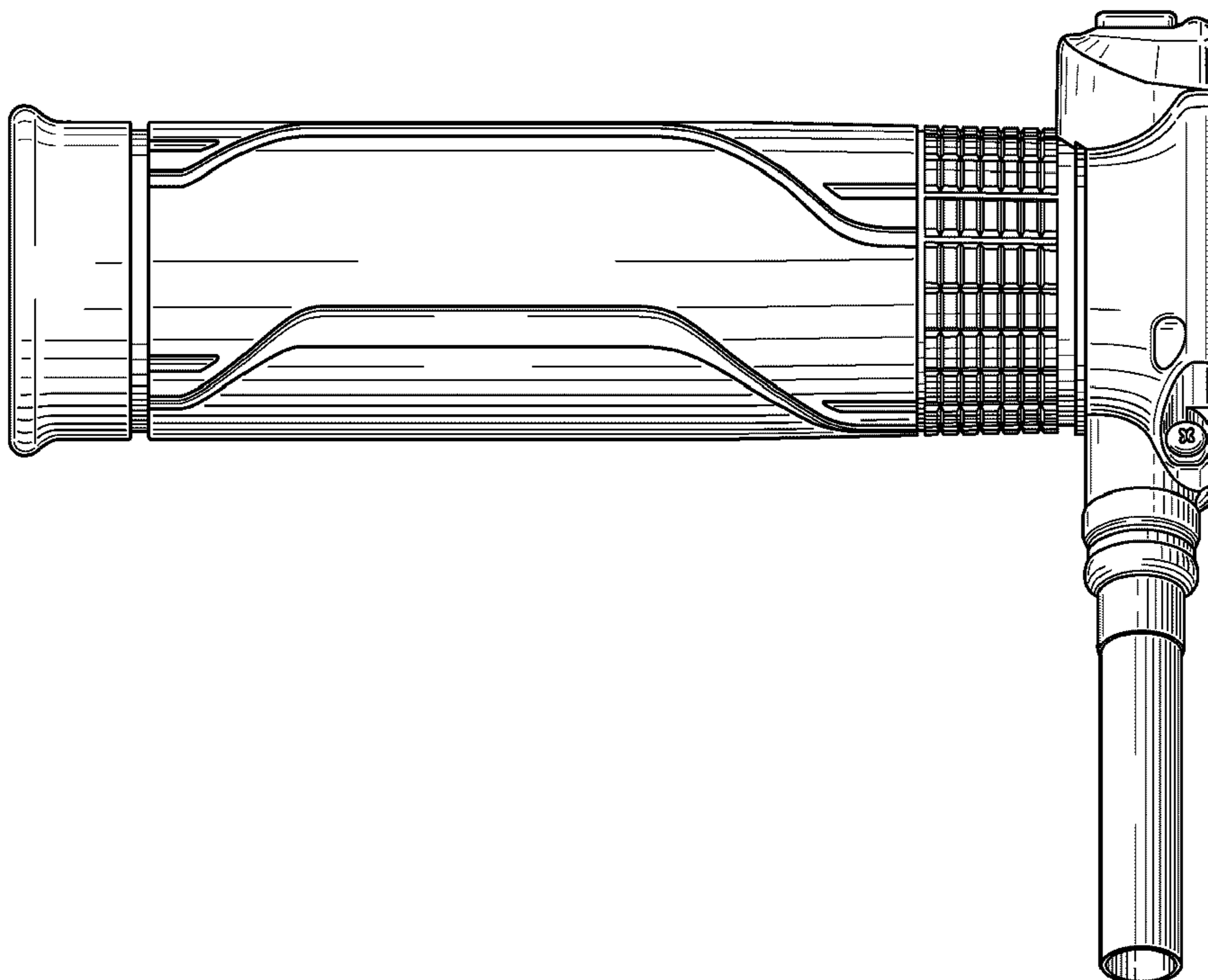

FIG.6

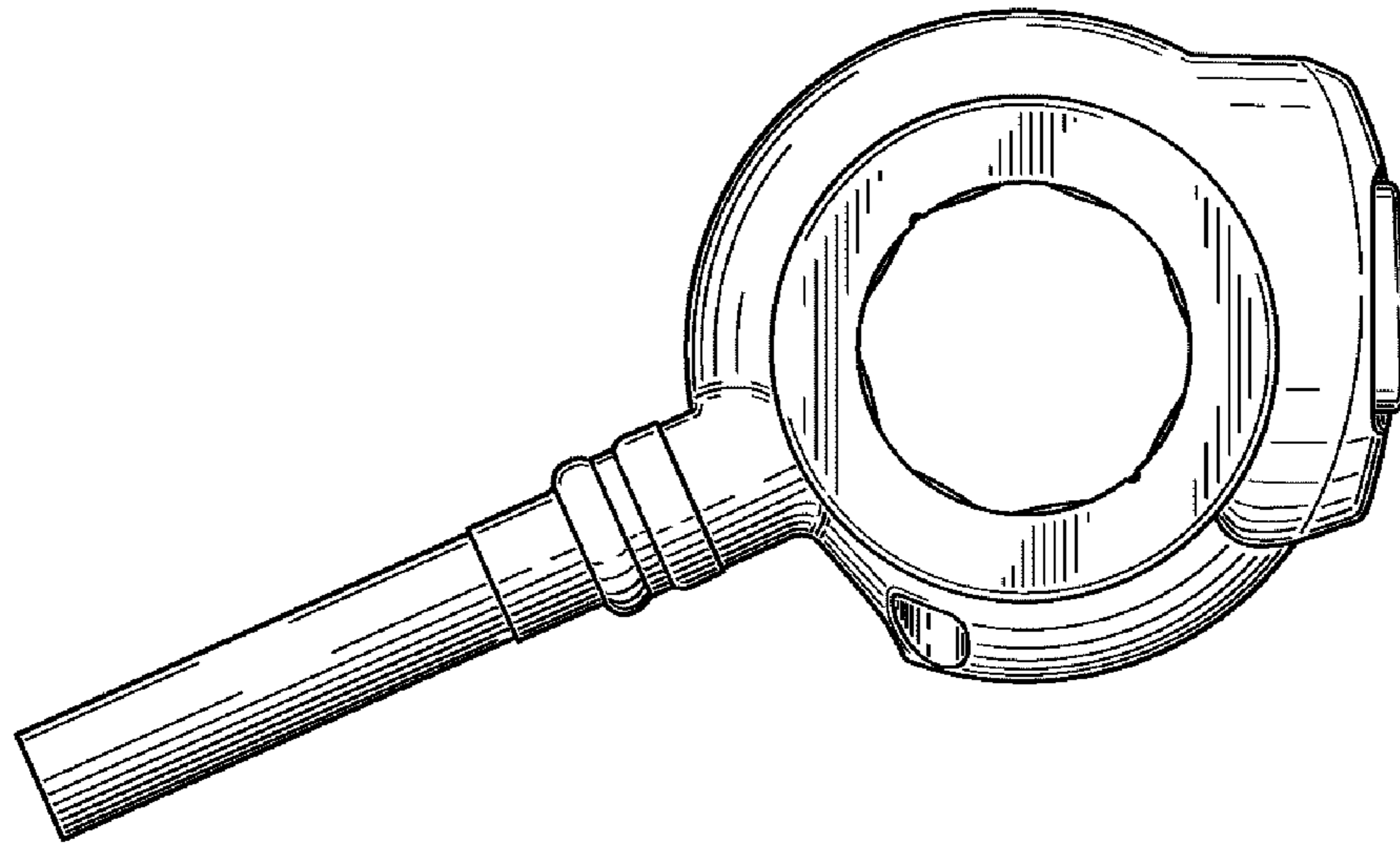

FIG.7

