



US00D654519S

(12) **United States Design Patent**
Wujczak et al.

(10) **Patent No.:** **US D654,519 S**

(45) **Date of Patent:** **** *Feb. 21, 2012**

(54) **POWER SOURCE FOR WELDING**

(75) Inventors: **Michal Wujczak**, Ostrow Wlkp (PL);
Tomasz Gramatyka, Lezajsk (PL)

(73) Assignee: **ESAB AB** (SE)

(*) Notice: This patent is subject to a terminal disclaimer.

(**) Term: **14 Years**

(21) Appl. No.: **29/349,150**

(22) Filed: **Mar. 11, 2010**

(30) **Foreign Application Priority Data**

Sep. 11, 2009 (EM) 001163984-0005

(51) **LOC (9) Cl.** **15-09**

(52) **U.S. Cl.** **D15/144**

(58) **Field of Classification Search** D8/29.1,
D8/30; D13/123, 133; D15/144, 144.1,
D15/144.2; 219/125.1, 130, 130.5, 132,
219/133, 241, 424, 606; 222/146.5, 152,
222/156, 189.06, 397; 228/8, 20, 51, 111.5
See application file for complete search history.

(56) **References Cited**

U.S. PATENT DOCUMENTS

D357,927 S * 5/1995 Soderholm D15/144.1
D386,148 S * 11/1997 Katooka et al. D13/110
5,734,148 A * 3/1998 Latvis et al. 219/133
D416,030 S * 11/1999 Weller et al. D15/144.1

D467,257 S * 12/2002 Andersson et al. D15/144
D520,038 S * 5/2006 Ljungfeldt D15/144.1
D569,884 S * 5/2008 Shu D15/144
2005/0212299 A1* 9/2005 Wang 290/1 A
2006/0027547 A1* 2/2006 Silvestro 219/133
2008/0047522 A1* 2/2008 Leisner et al. 123/198 D

* cited by examiner

Primary Examiner — Patricia Palasik

(74) *Attorney, Agent, or Firm* — Lerner, David, Littenberg,
Krumholz & Mentlik, LLP

(57) **CLAIM**

The ornamental design for a power source for welding, as shown and described.

DESCRIPTION

FIG. 1 is a perspective view of a power source for welding, in accordance with the present invention;
FIG. 2 is a front elevation view of the power source for welding shown in FIG. 1;
FIG. 3 is a rear elevation view of the power source for welding shown in FIG. 1;
FIG. 4 is a right side elevation view of the power source for welding shown in FIG. 1;
FIG. 5 is a left side elevation view of the power source for welding shown in FIG. 1;
FIG. 6 is a top plan view of the power source for welding shown in FIG. 1; and,
FIG. 7 is a bottom plan view of the power source for welding shown in FIG. 1.

1 Claim, 7 Drawing Sheets

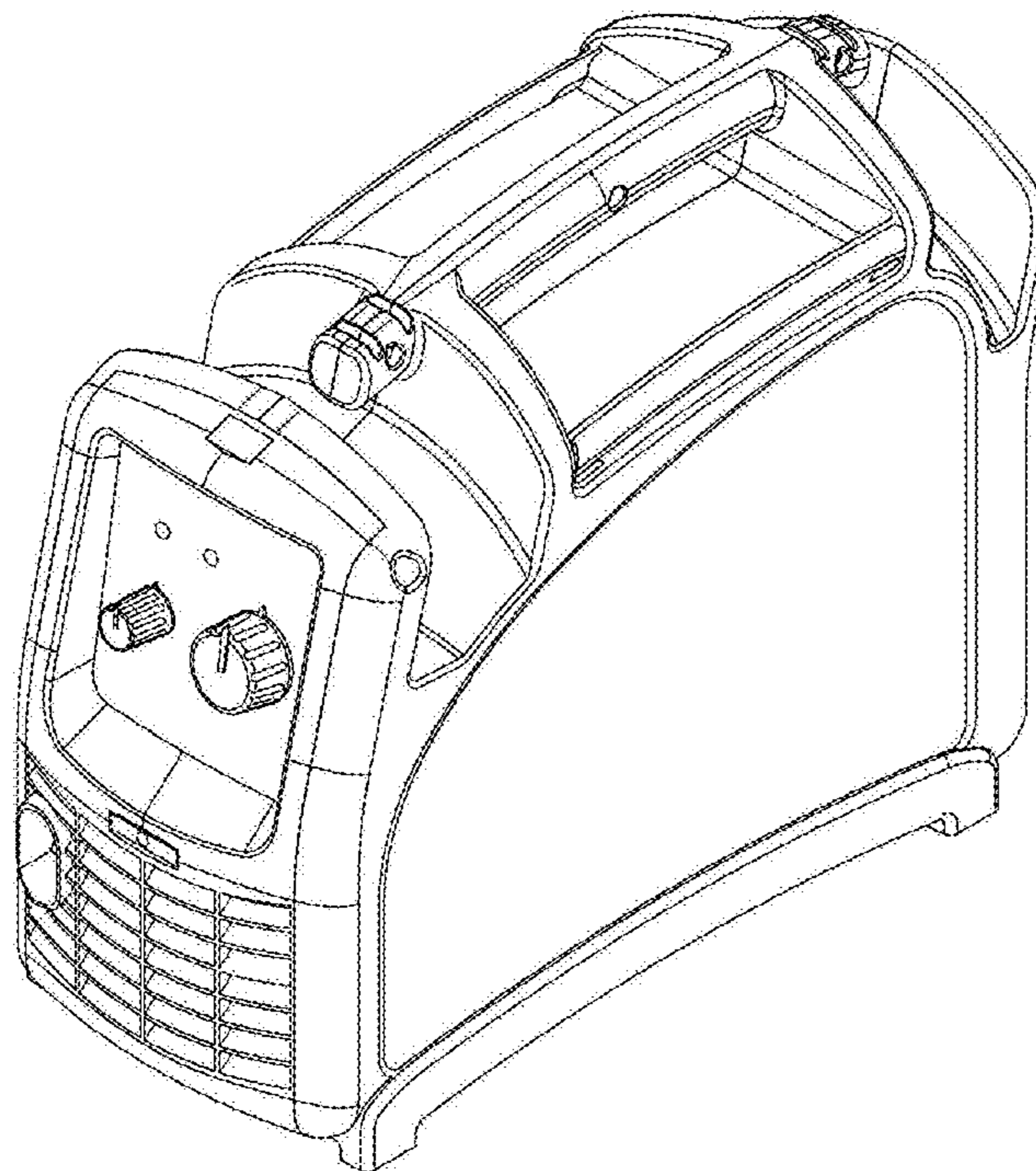

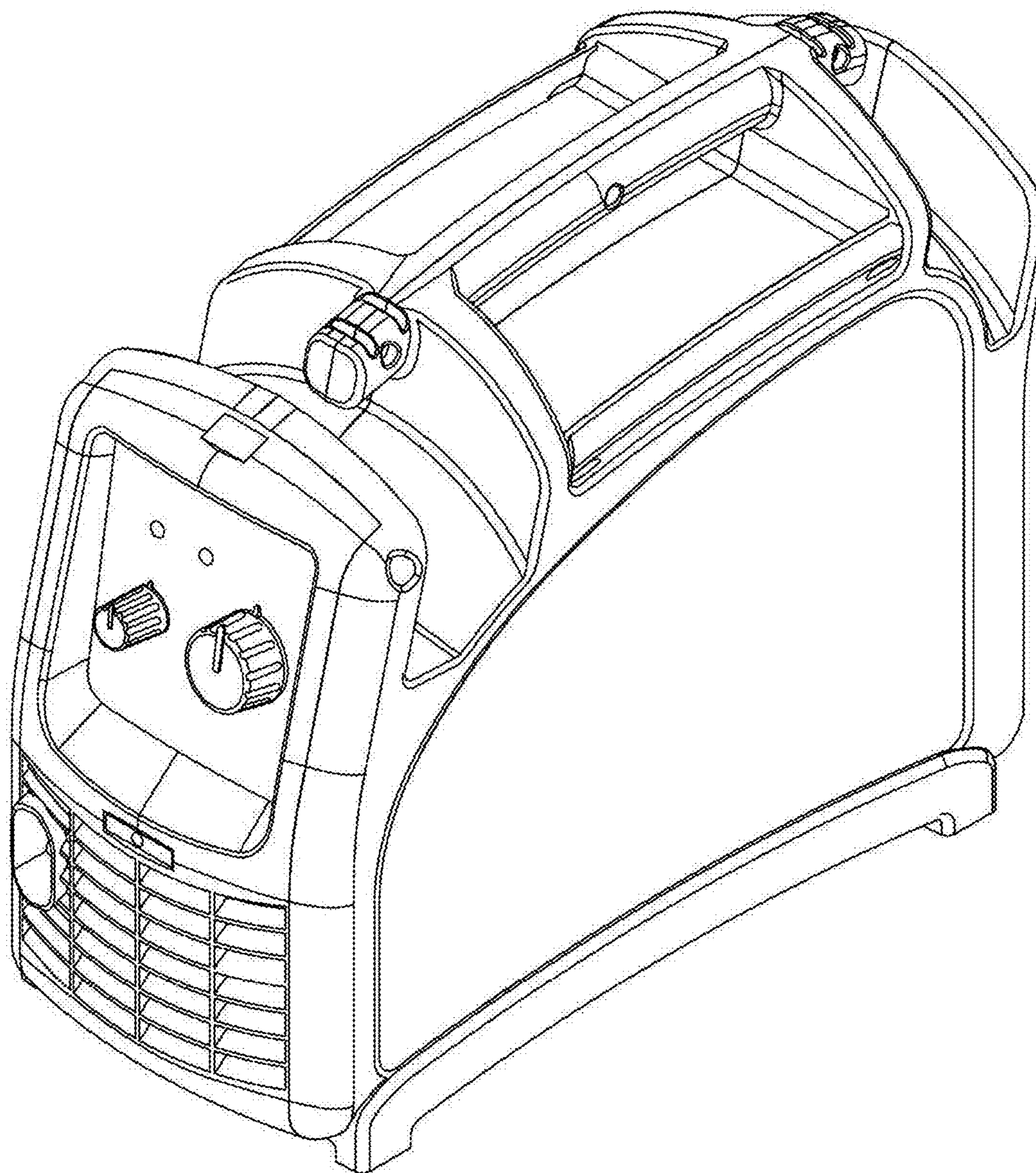

Fig. 1

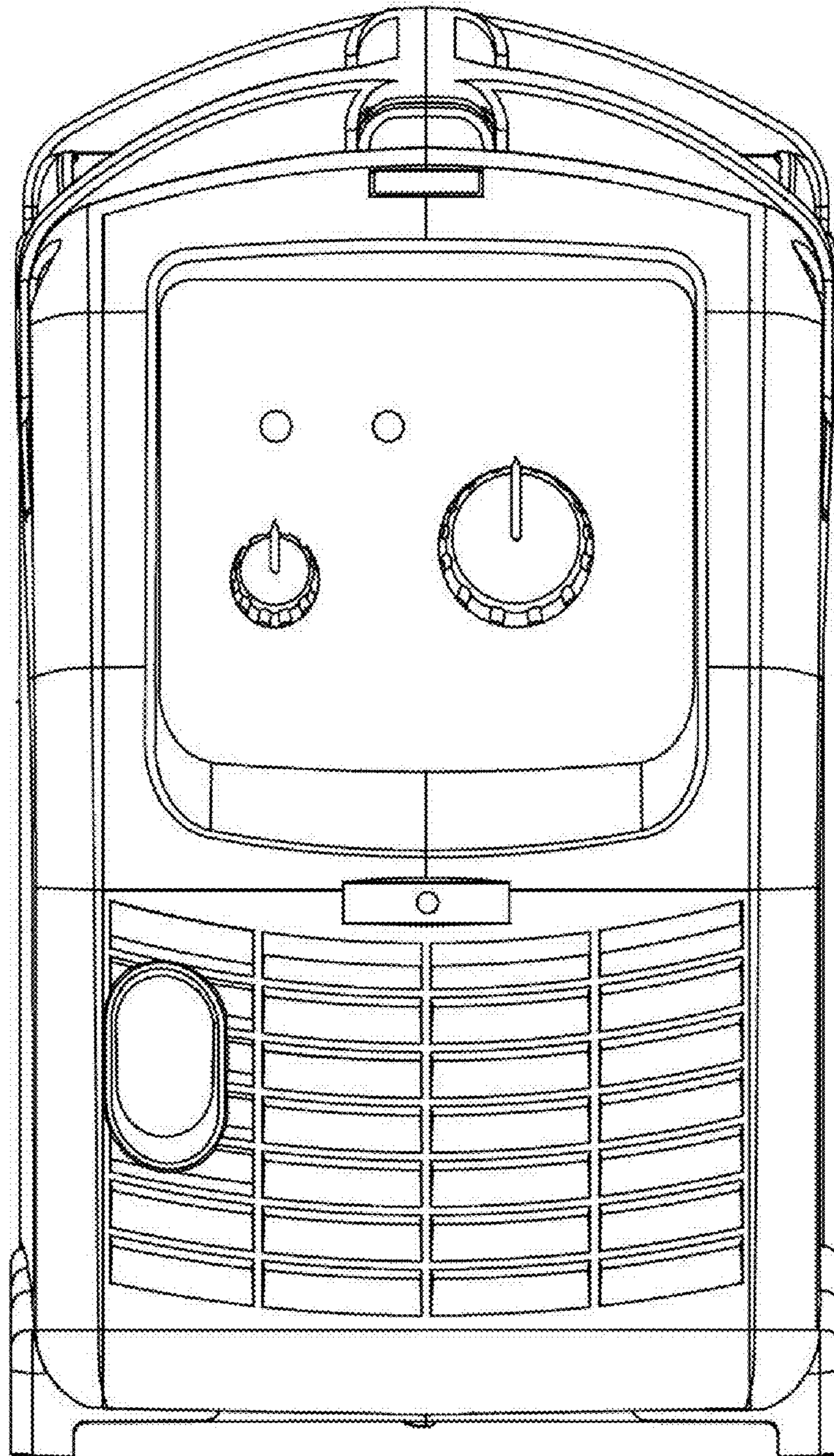

Fig. 2

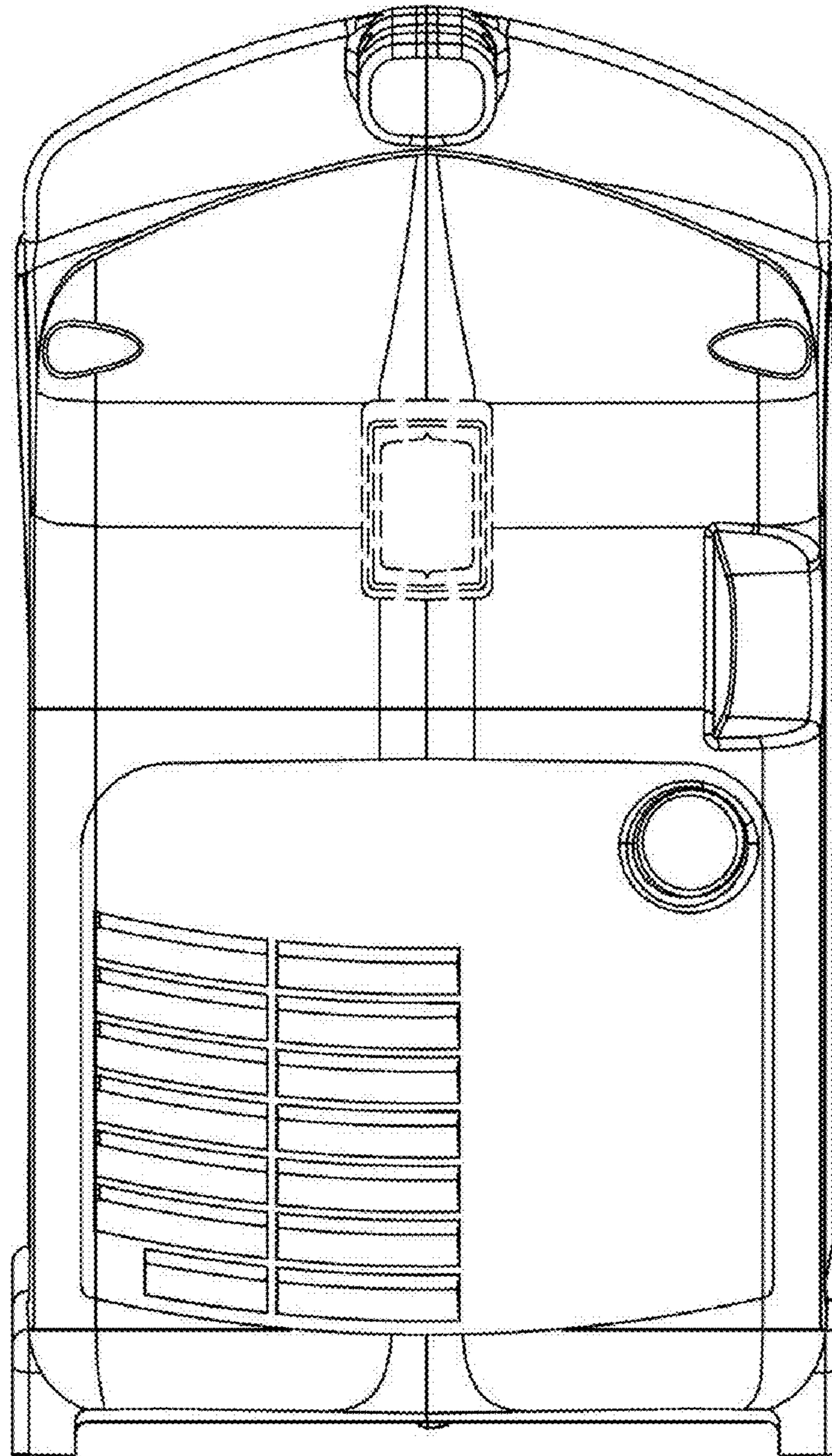

Fig. 3

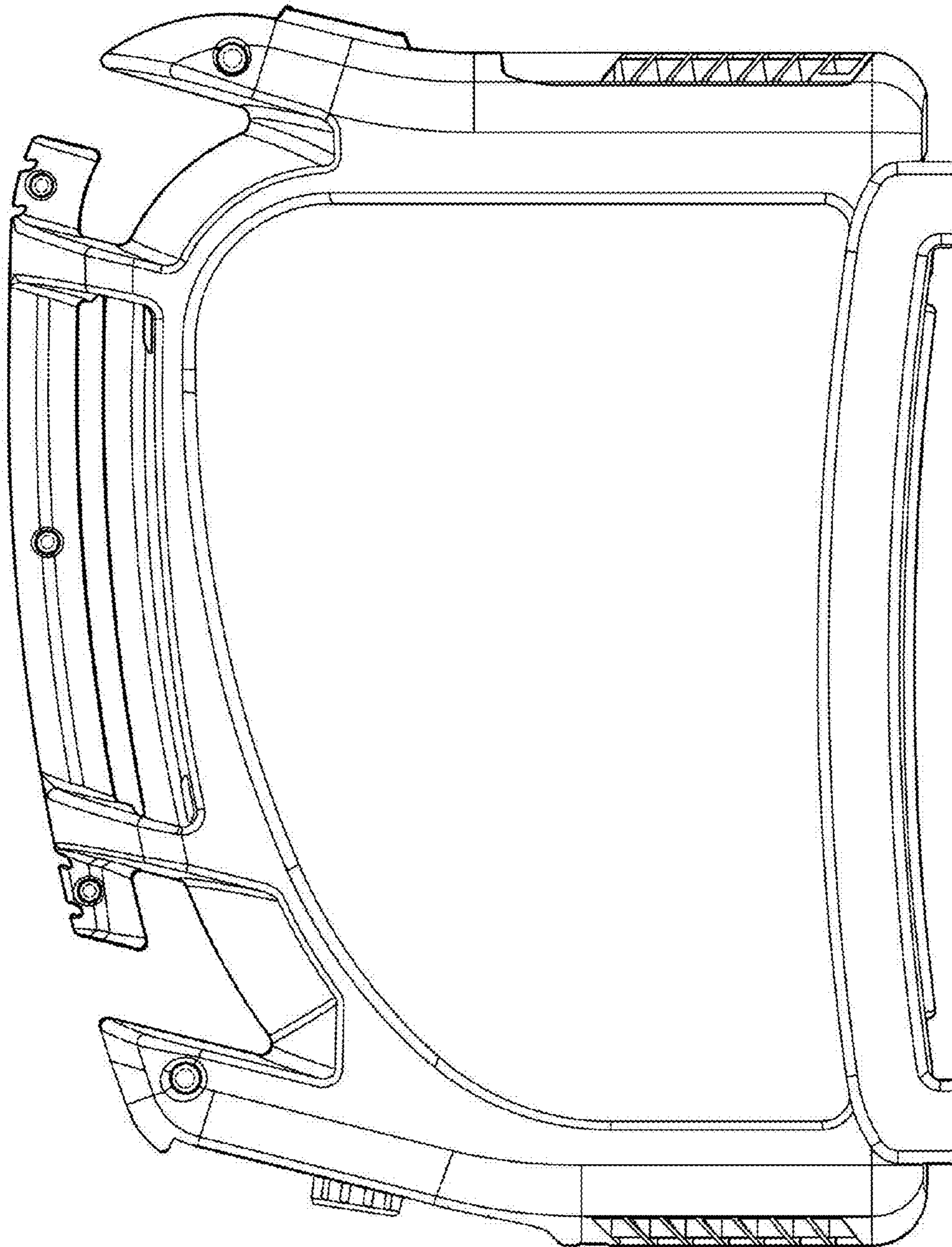

Fig. 4

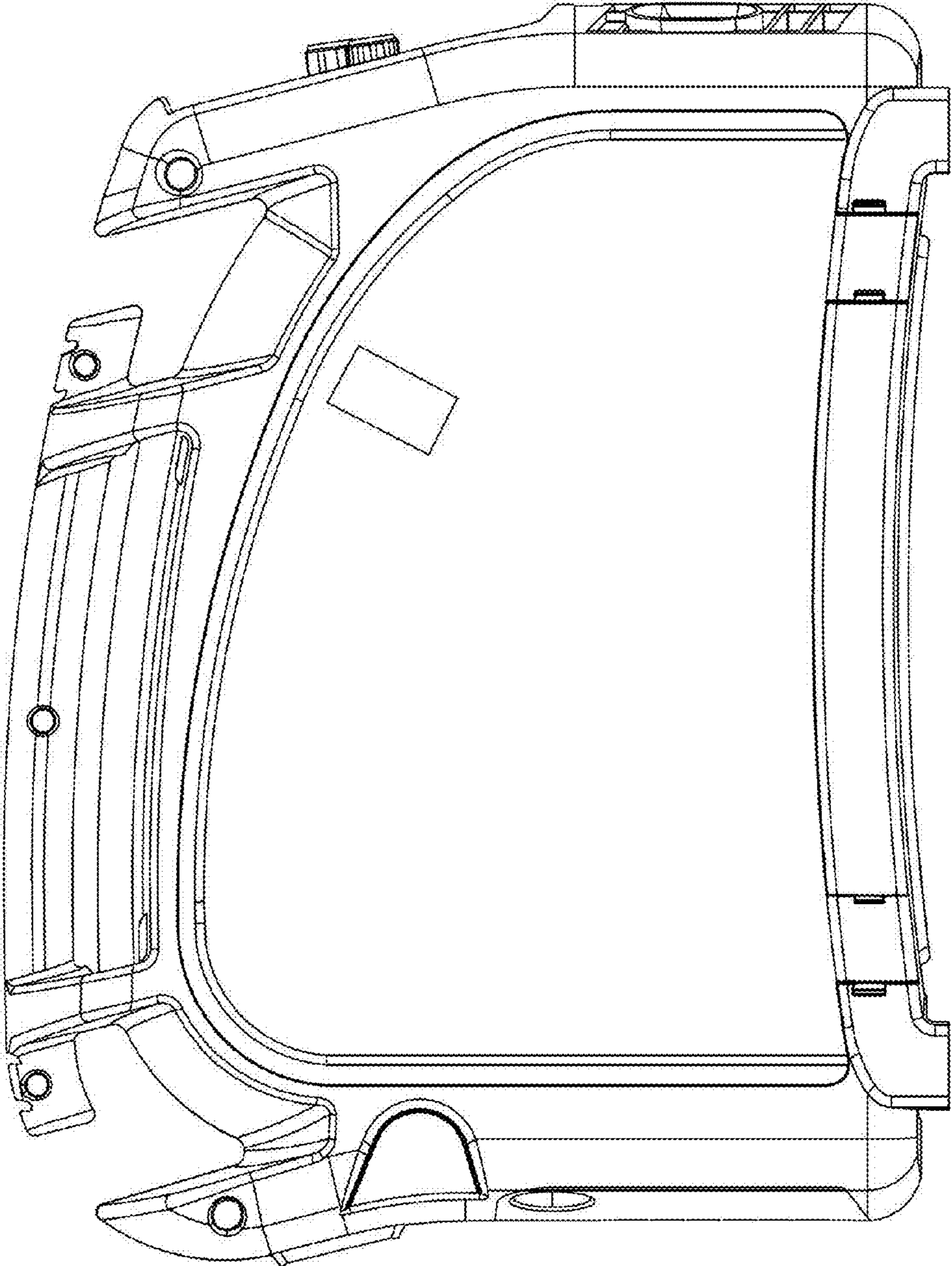

Fig. 5

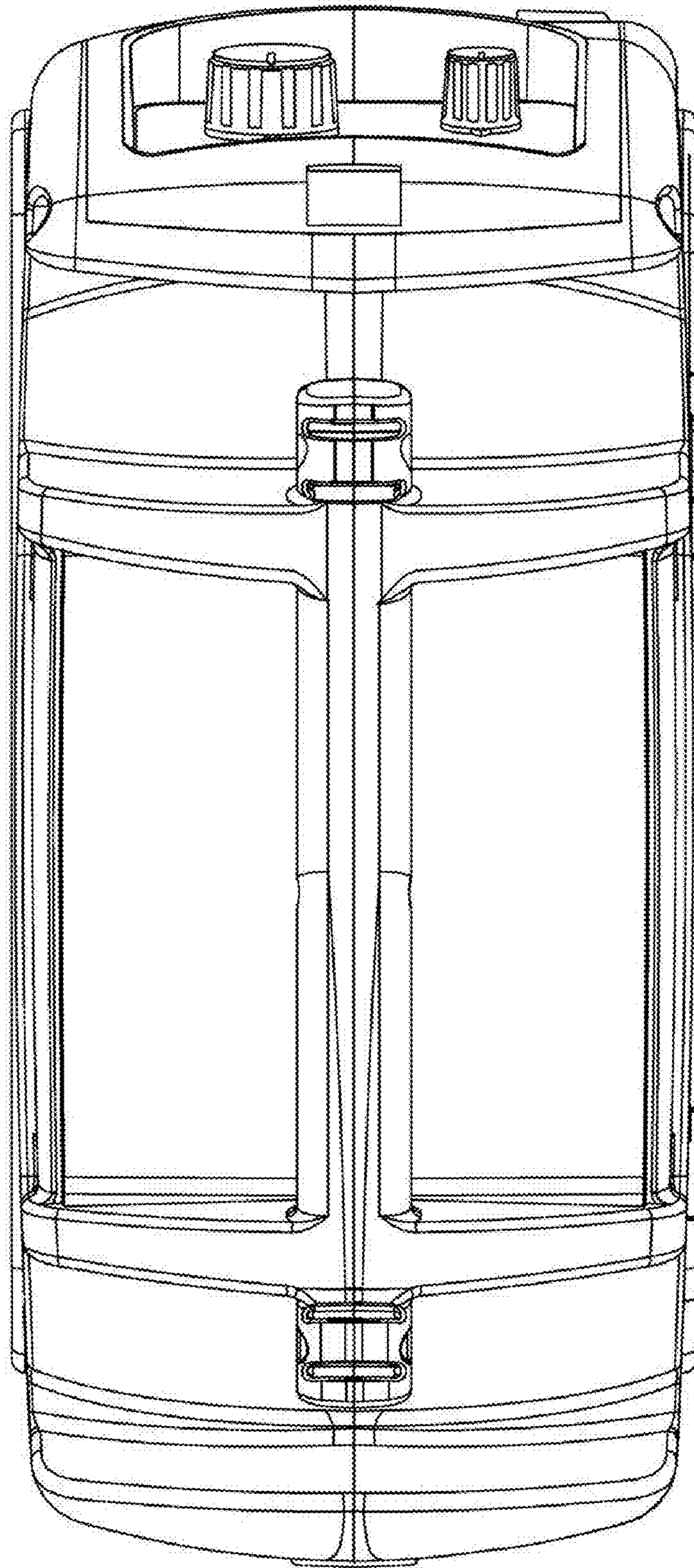

Fig. 6

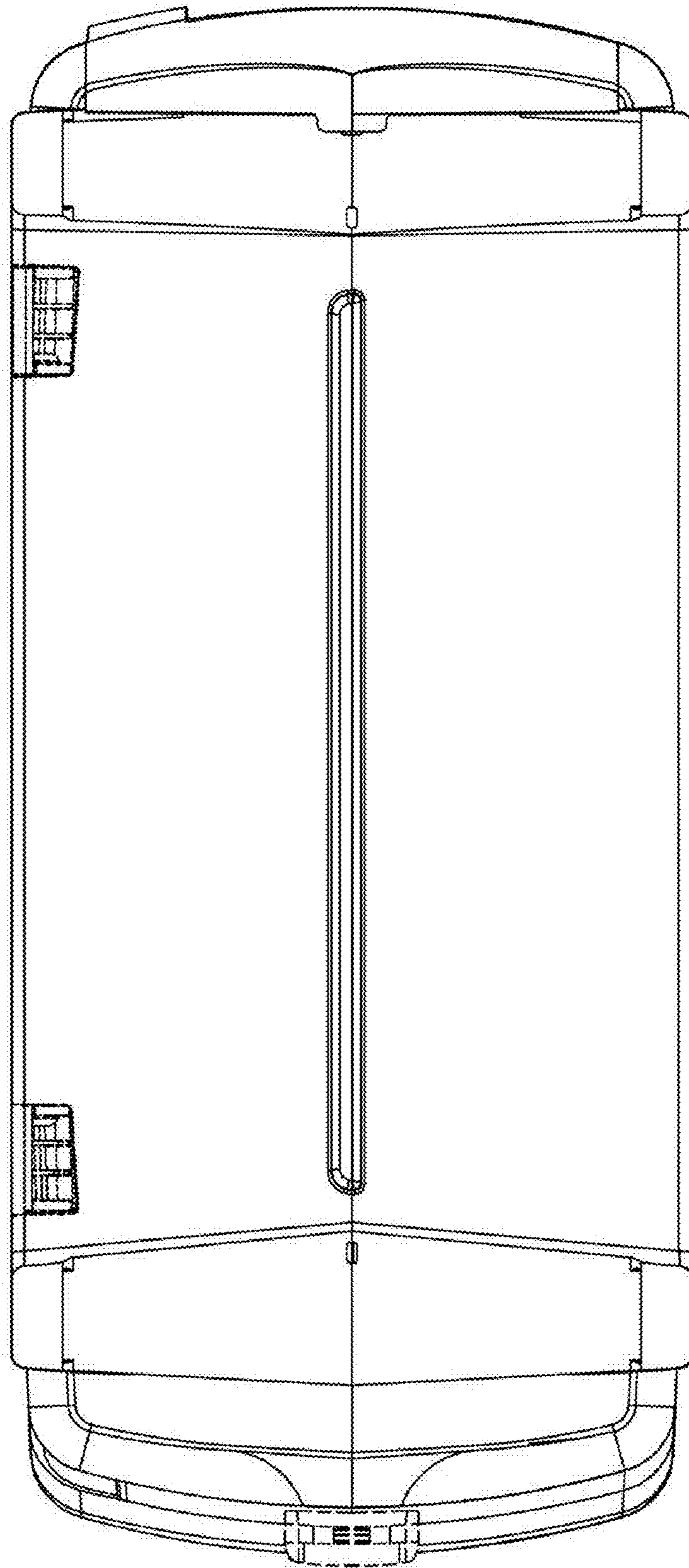

Fig. 7