



US00D654479S

(12) **United States Design Patent**
Bogdanov et al.

(10) **Patent No.:** **US D654,479 S**

(45) **Date of Patent:** **** Feb. 21, 2012**

(54) **LOUDSPEAKER DRIVER SUSPENSION**

(75) Inventors: **Oleg Bogdanov**, Toronto (CA); **Kevin Alexander Stitt**, Brampton (CA)

(73) Assignee: **Paradigm Electronics Inc.**, Mississauga (CA)

(**) Term: **14 Years**

(21) Appl. No.: **29/353,400**

(22) Filed: **Jan. 7, 2010**

(51) **LOC (9) Cl.** **14-01**

(52) **U.S. Cl.** **D14/221**

(58) **Field of Classification Search** D14/204,
D14/210–217, 221, 224, 172; 181/143–144,
181/147–148, 150–153, 157, 172, 198–199;
381/300–303, 306, 332–333, 336, 345, 361–364,
381/386–388, 398

See application file for complete search history.

(56) **References Cited**

U.S. PATENT DOCUMENTS

3,676,722	A	7/1972	Schafft	
3,997,023	A	12/1976	White	
D357,480	S	4/1995	Lumsden et al.	
5,734,132	A	3/1998	Proni	
5,862,242	A *	1/1999	Takewa et al.	381/398
6,224,801	B1	5/2001	Mango, III	
6,305,491	B2	10/2001	Iwasa et al.	
6,611,604	B1	8/2003	Irby et al.	
6,697,496	B2	2/2004	Frasl	
6,725,967	B2	4/2004	Hlibowicki	
6,851,513	B2	2/2005	Stead et al.	
6,889,796	B2	5/2005	Pocock et al.	
7,054,459	B2	5/2006	Kuze et al.	
7,174,990	B2	2/2007	Stead et al.	
7,275,620	B1	10/2007	Diedrich et al.	
7,397,927	B2	7/2008	Pircaro et al.	

7,428,946	B2 *	9/2008	Honda et al.	181/171
7,438,155	B2	10/2008	Stead et al.	
2003/0228027	A1	12/2003	Czerwinski	

* cited by examiner

Primary Examiner — Nanda Bondade

(74) *Attorney, Agent, or Firm* — Thomas Adams

(57) **CLAIM**

We claim the ornamental design for a loudspeaker driver suspension, as shown and described.

DESCRIPTION

FIG. 1 is a perspective view of a circular loudspeaker driver suspension with the surrounding flange and frame shown in broken lines;

FIG. 2 is a top plan view of the loudspeaker driver suspension shown in FIG. 1;

FIG. 3 is a side elevation view of the loudspeaker driver suspension;

FIG. 4 is a top plan view showing the loudspeaker driver suspension without the surrounding loudspeaker frame;

FIG. 5 shows a small portion of the suspension cut at a position where its height is a maximum, namely lines V-V of FIG. 2;

FIG. 6 shows a small portion of the suspension similar to that shown in FIG. 5 but cut at a position where its height is a minimum, namely at lines VI-VI of FIG. 2;

FIG. 7 is a side view of a portion of the suspension cut away at lines VII-VII of FIG. 2;

FIG. 8 is a perspective view of a variant of the design in the form of an obround loudspeaker driver suspension with the surrounding flange and frame shown in broken lines;

FIG. 9 is a top plan view of the loudspeaker suspension of FIG. 8; and,

FIG. 10 is a side elevation view of the loudspeaker suspension of FIGS. 8 and 9.

Parts of the loudspeaker driver suspension and frame shown in broken lines illustrate environment only and do not form part of the design.

1 Claim, 10 Drawing Sheets

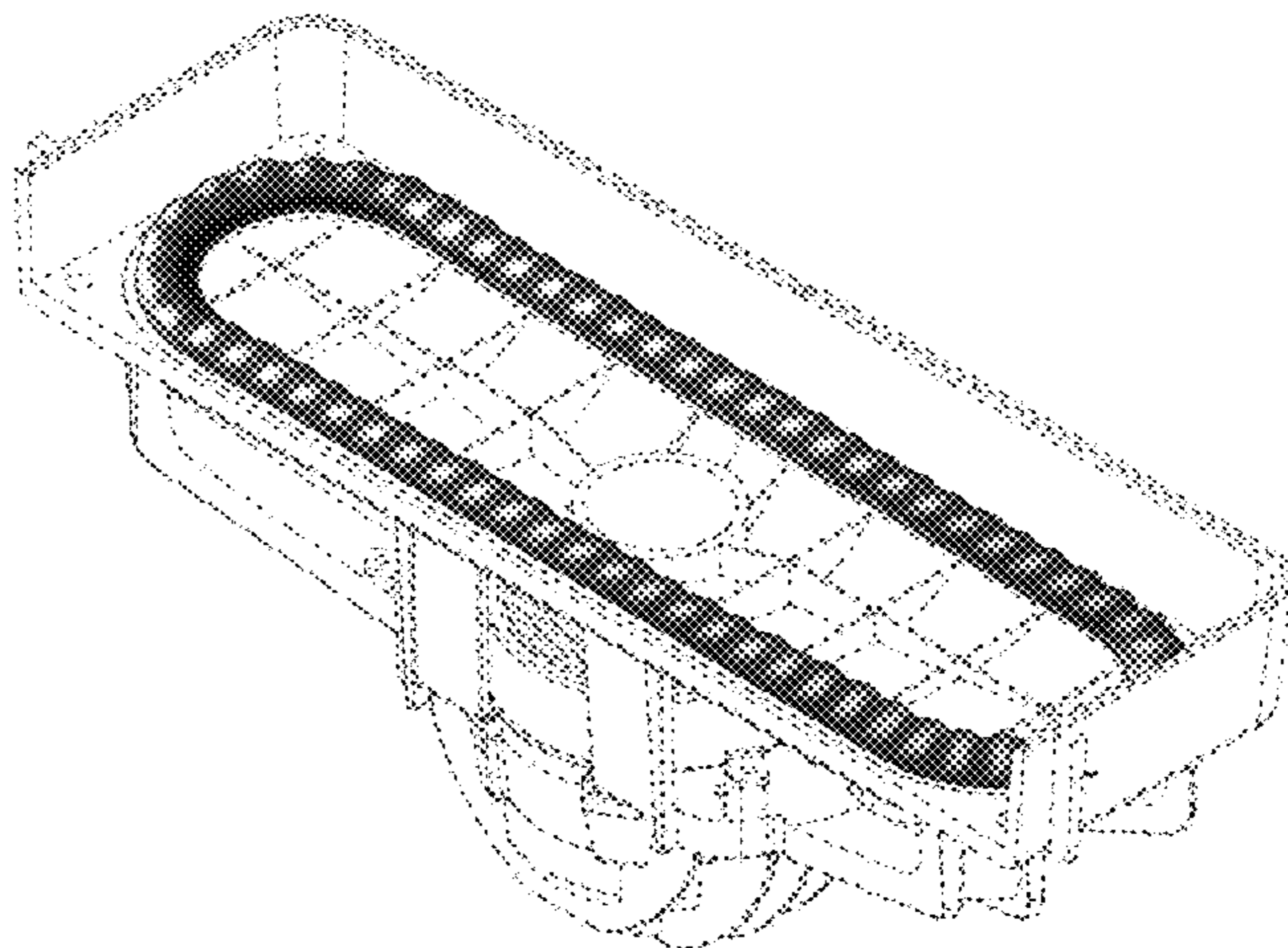
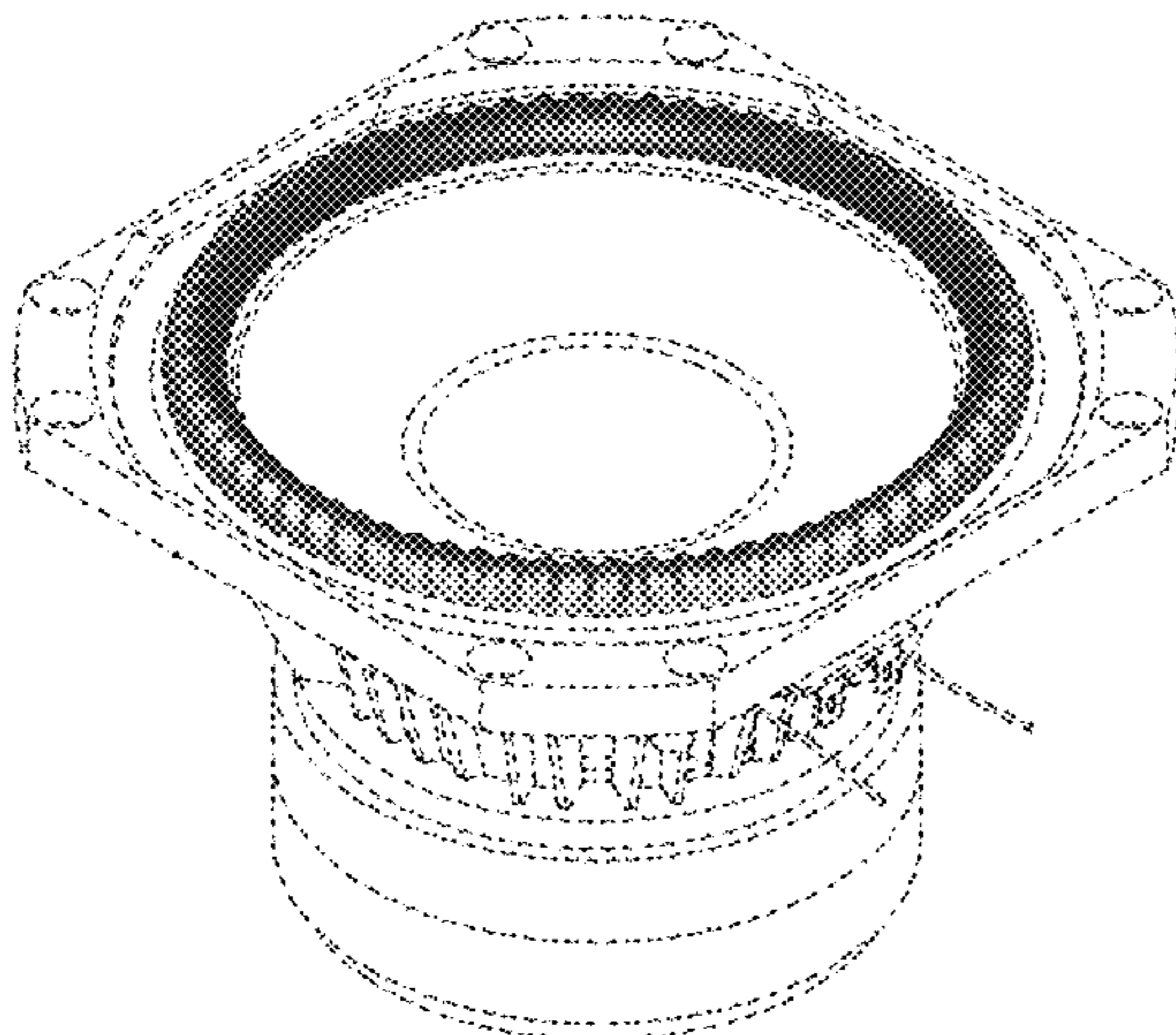

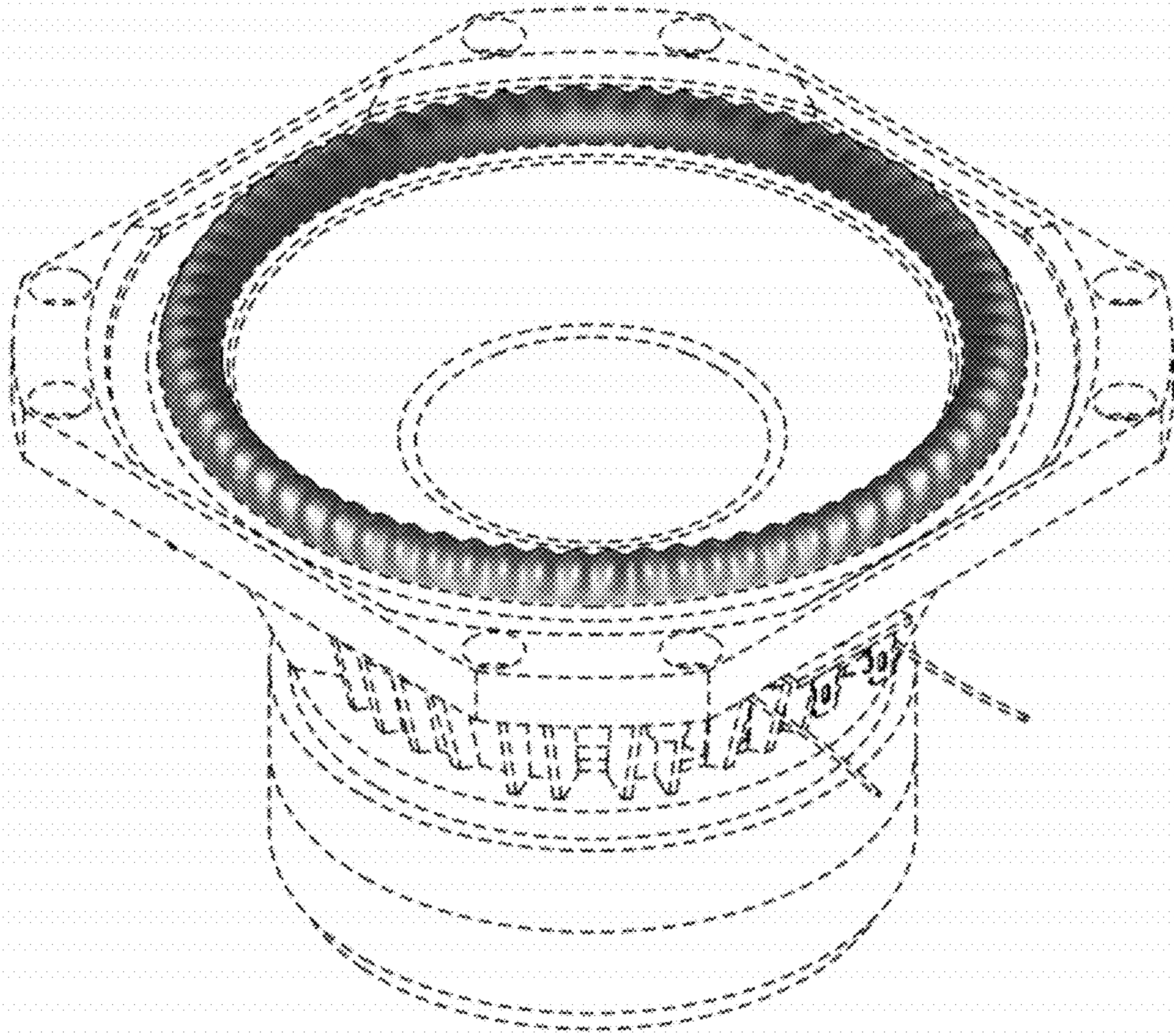

Figure 1

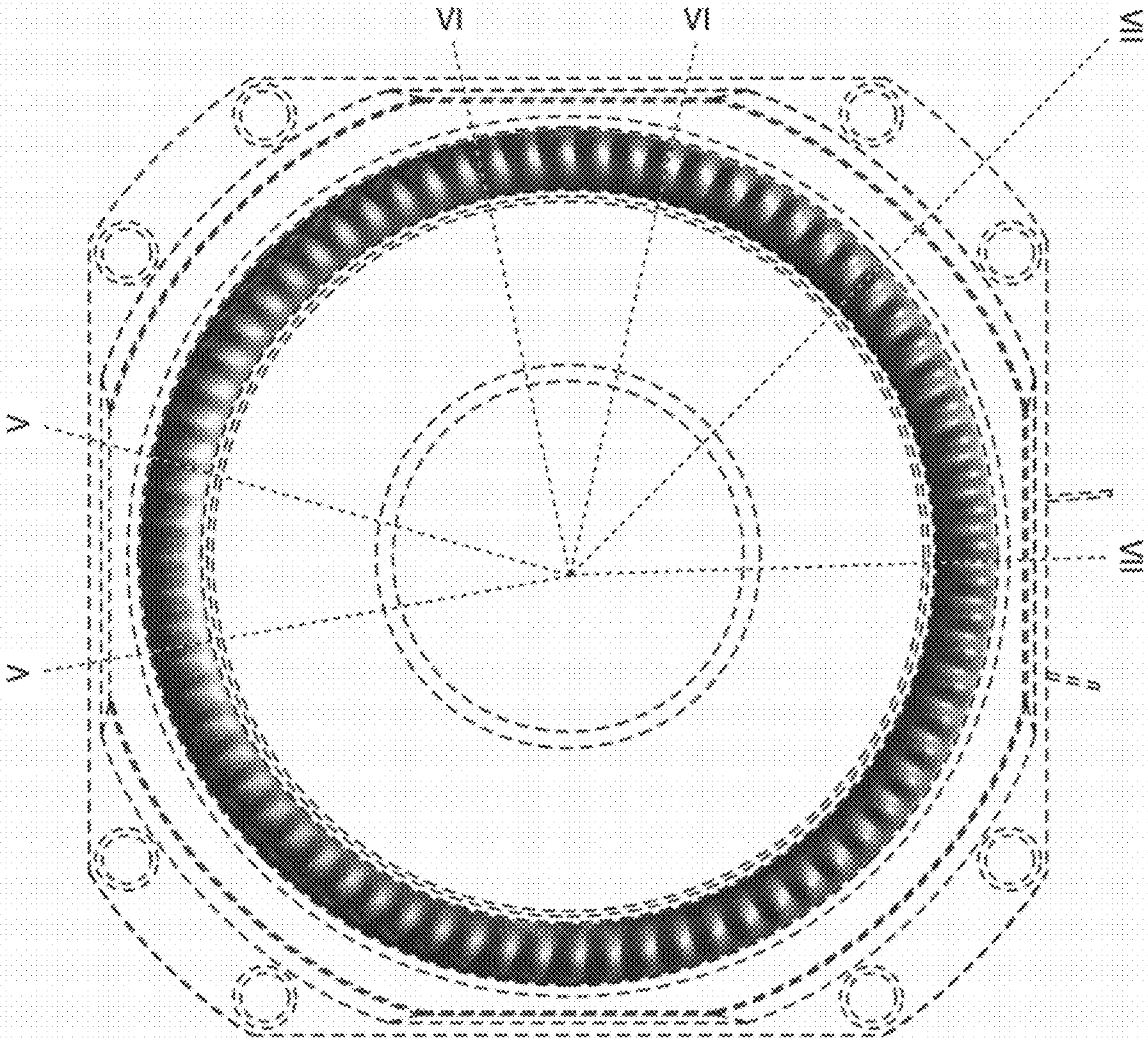

Figure 2

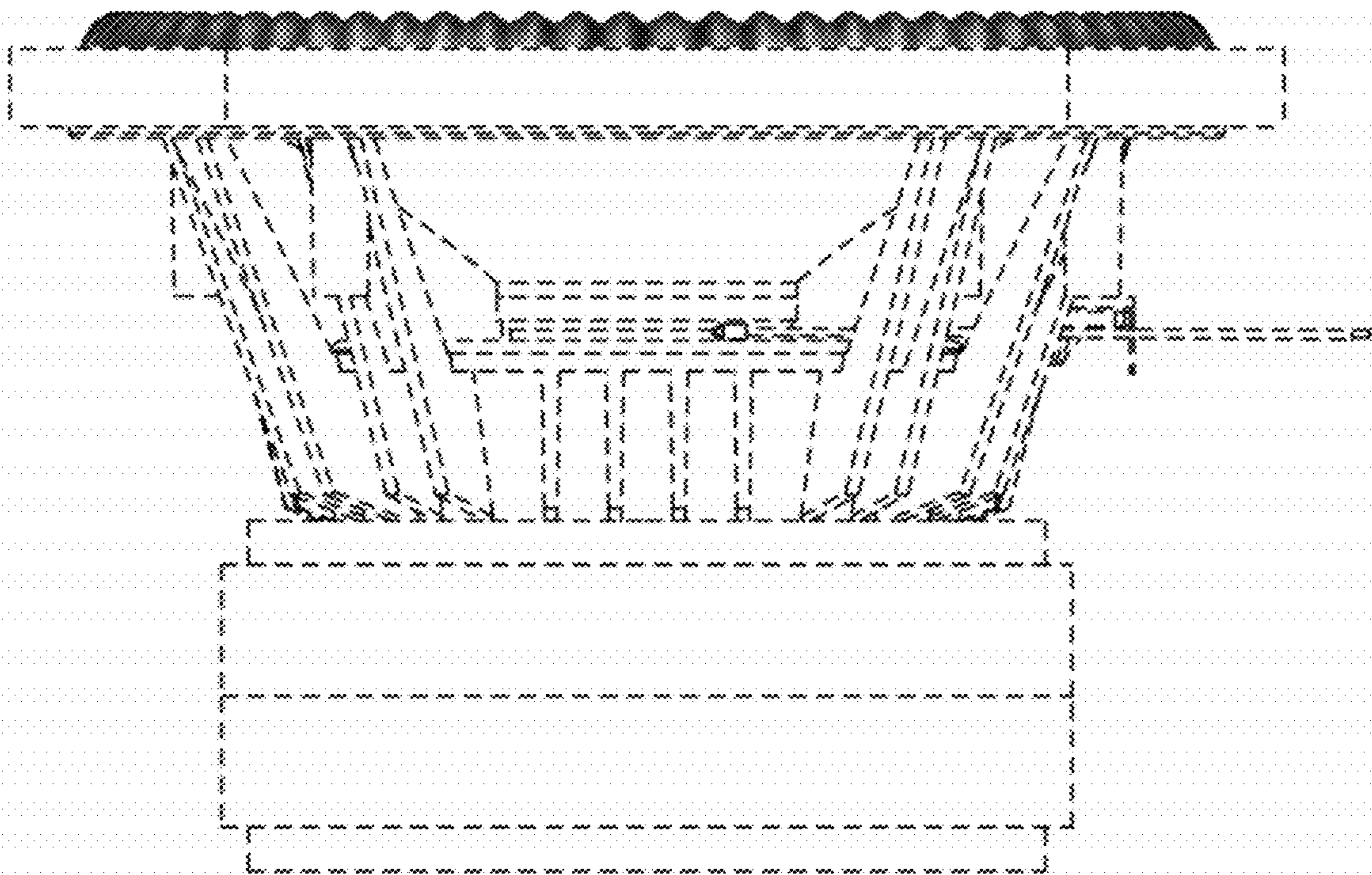

Figure 3

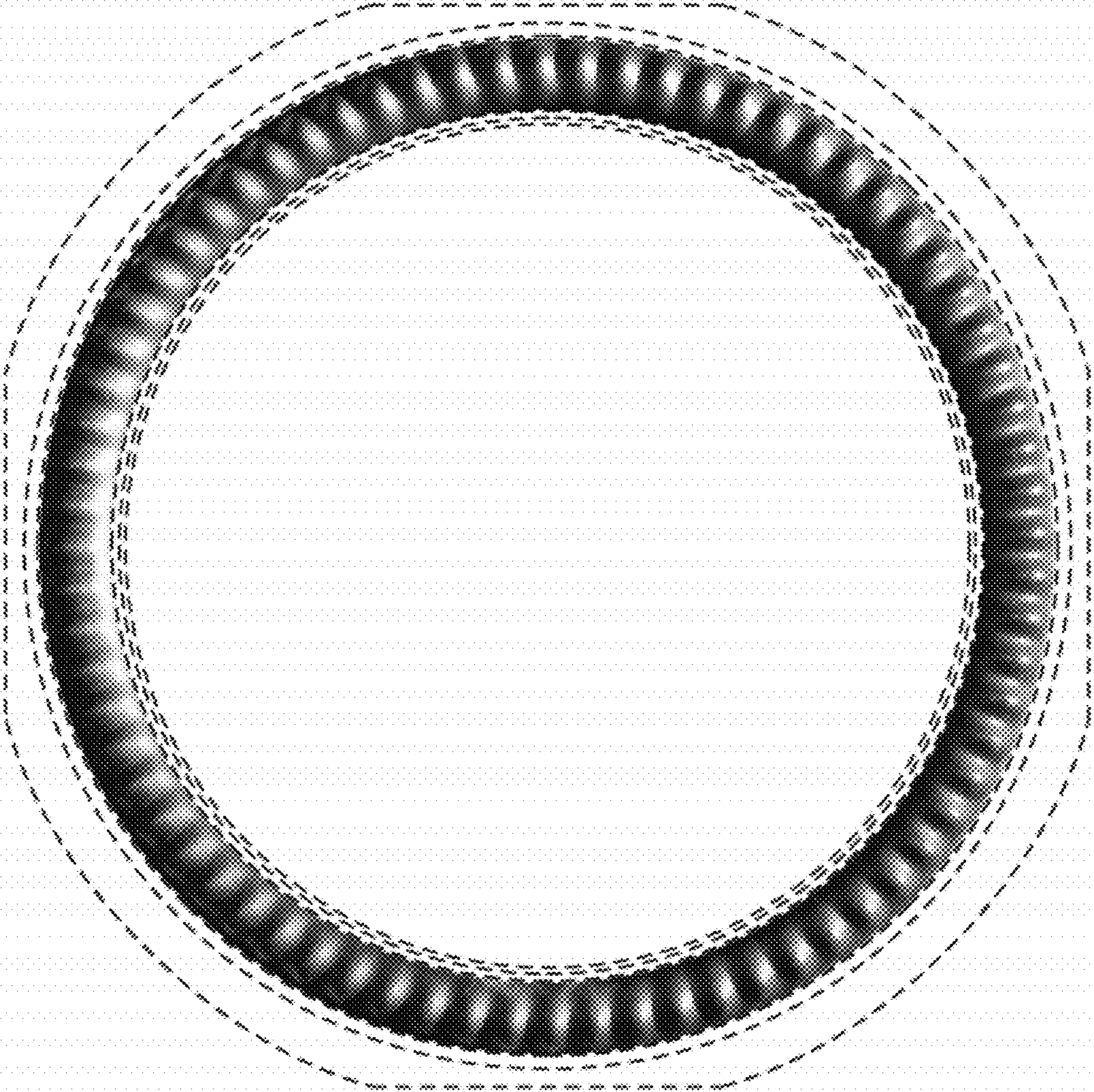

Figure 4

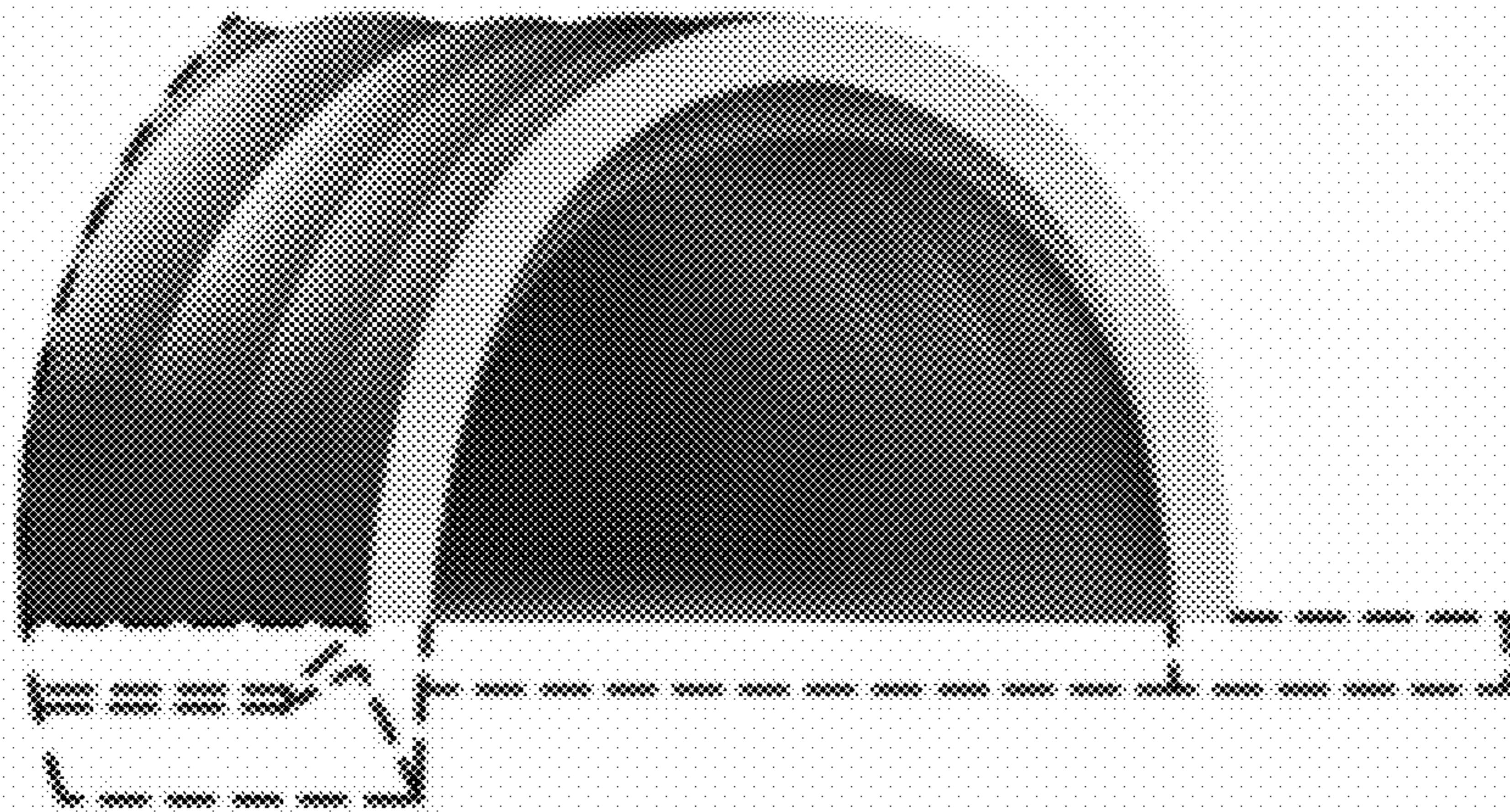

Figure 5

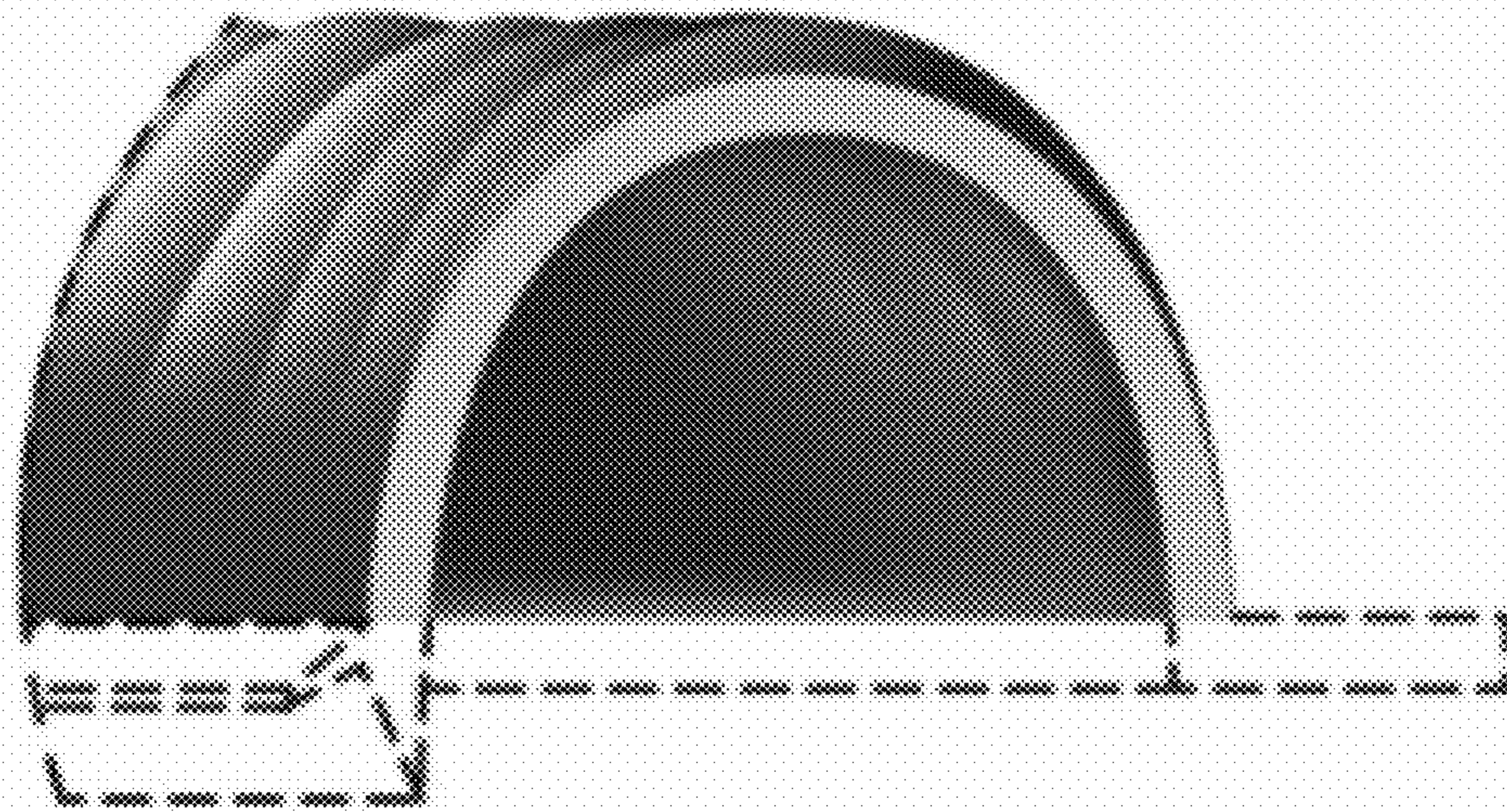

Figure 6

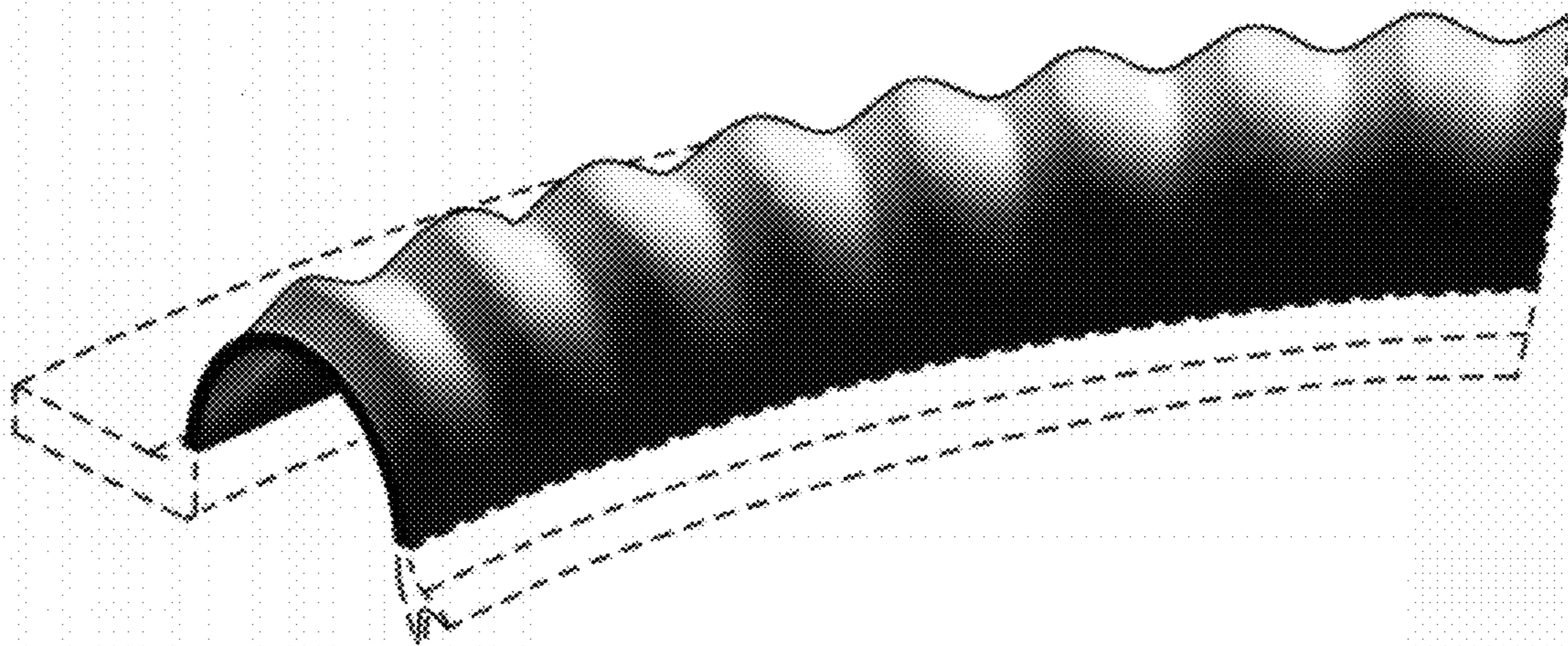

Figure 7

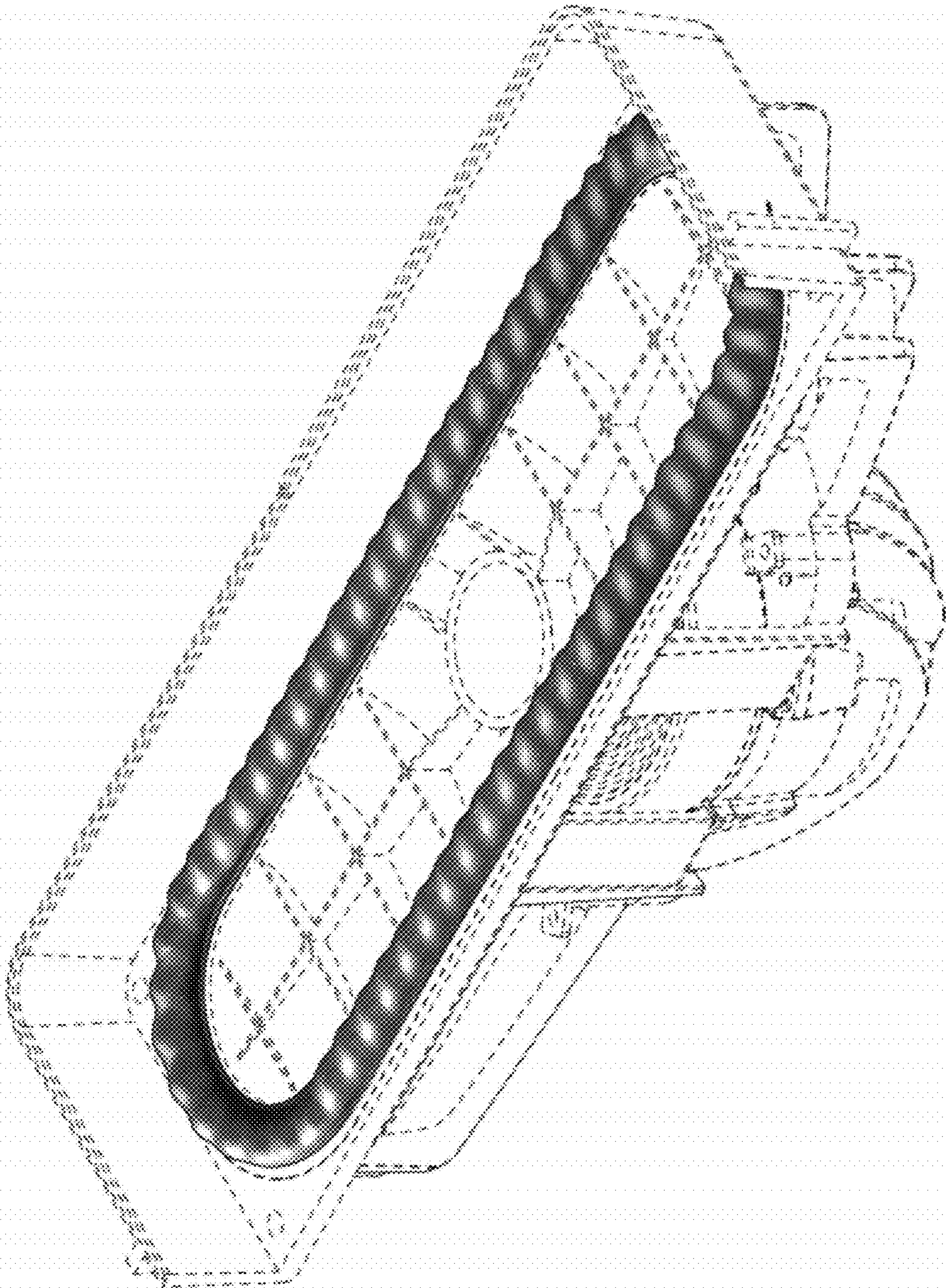

Figure 8

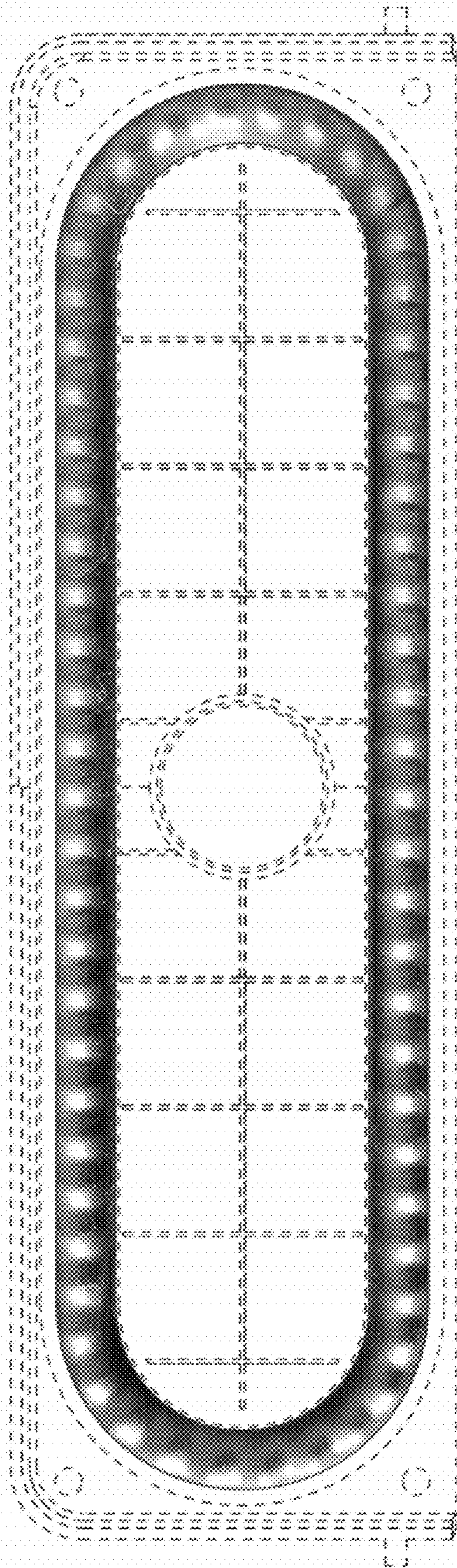

Figure 9

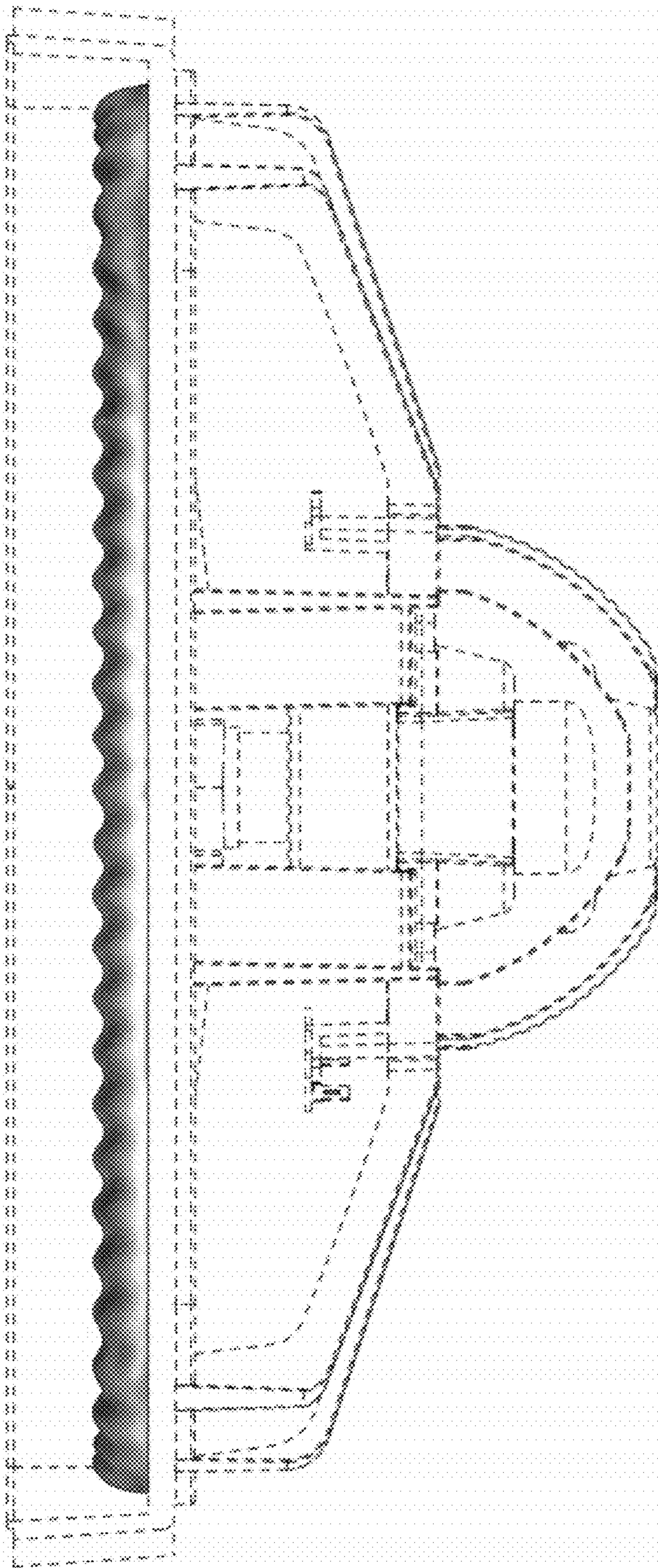

Figure 10