



US00D654191S

(12) **United States Design Patent**  
**Wink**

(10) **Patent No.:** **US D654,191 S**  
(45) **Date of Patent:** **\*\* Feb. 14, 2012**

- (54) **FLEXIBLE LANDSCAPE EDGING**
- (75) Inventor: **John S. Wink**, Tampa, FL (US)
- (73) Assignee: **Novel Ideas, Inc.**, Riverview, FL (US)
- (\*\*) Term: **14 Years**
- (21) Appl. No.: **29/371,745**
- (22) Filed: **Aug. 18, 2011**

6,085,458 A 7/2000 Gau  
 6,591,547 B1 \* 7/2003 Staten et al. .... 47/33  
 D601,274 S 9/2009 Koenig, Jr.

\* cited by examiner

*Primary Examiner* — Doris Clark

(74) *Attorney, Agent, or Firm* — Nixon IP Law, PLC;  
William F. Nixon

(57) **CLAIM**

The ornamental design for a flexible landscape edging, as shown and described.

**Related U.S. Application Data**

- (63) Continuation-in-part of application No. 12/291,315, filed on Nov. 7, 2008.
- (51) **LOC (9) Cl.** ..... **25-01**
- (52) **U.S. Cl.** ..... **D25/164; D25/119**
- (58) **Field of Classification Search** ..... D25/119,  
D25/164; 52/102; 47/33  
See application file for complete search history.

**DESCRIPTION**

FIG. 1 is a right side perspective view of a flexible landscape edging, showing my new design;  
 FIG. 2 is a front view thereof;  
 FIG. 3 is a back view thereof;  
 FIG. 4 is a top view thereof;  
 FIG. 5 is a bottom view thereof;  
 FIG. 6 is a left side view thereof;  
 FIG. 7 is a right side view thereof; and,  
 FIG. 8 is an enlarged cross-sectional view taken along line 8-8 in FIG. 2.

The broken line showing of the flexible landscape edging is for the purpose of illustrating a hole and forms no part of the claimed design.

(56) **References Cited**

**U.S. PATENT DOCUMENTS**

3,087,279 A \* 4/1963 Thompson ..... 47/33  
 4,986,042 A \* 1/1991 Richardt ..... 52/102  
 D363,788 S \* 10/1995 Caley ..... D25/119  
 D385,635 S \* 10/1997 Nebelsieck ..... D25/164

**1 Claim, 4 Drawing Sheets**

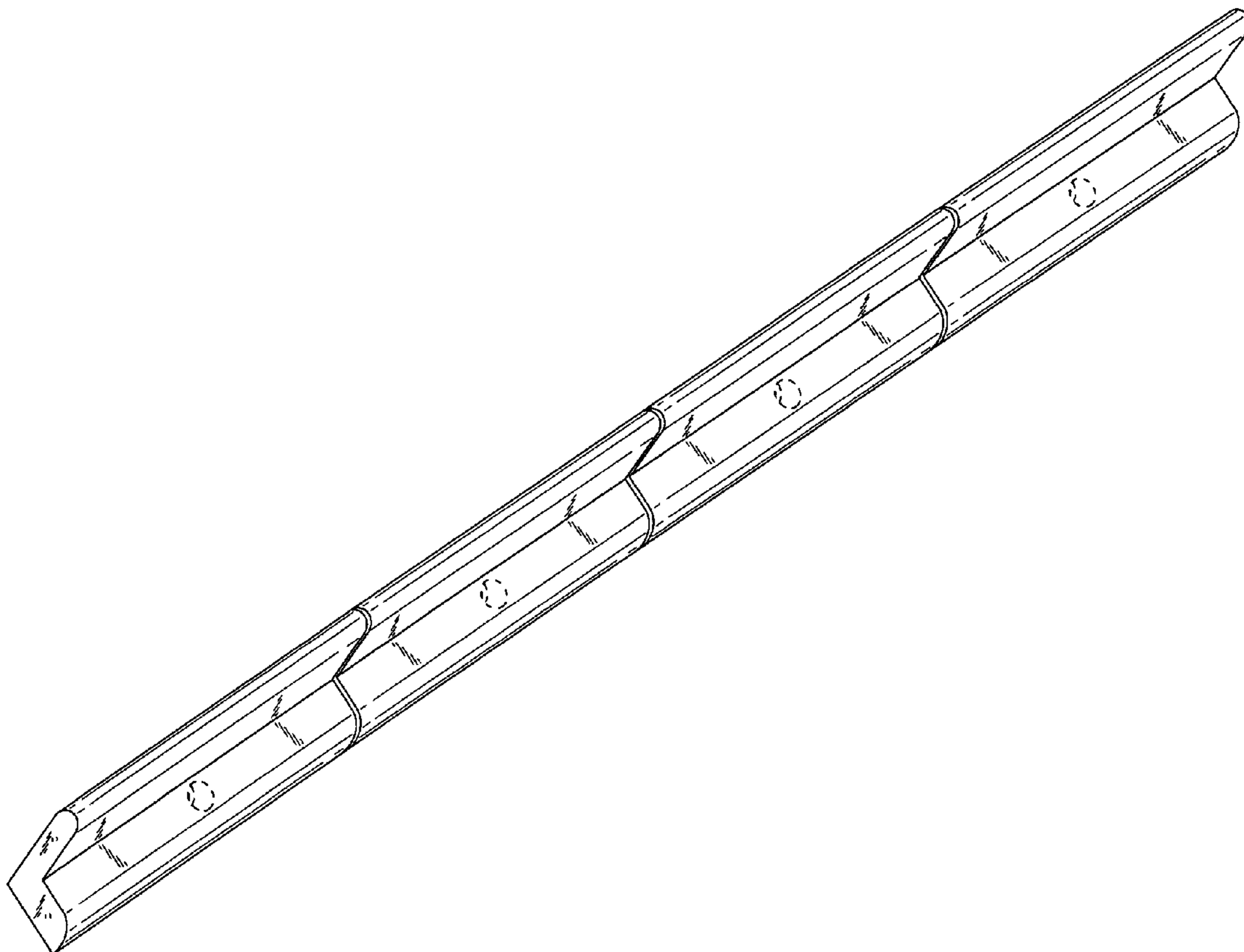

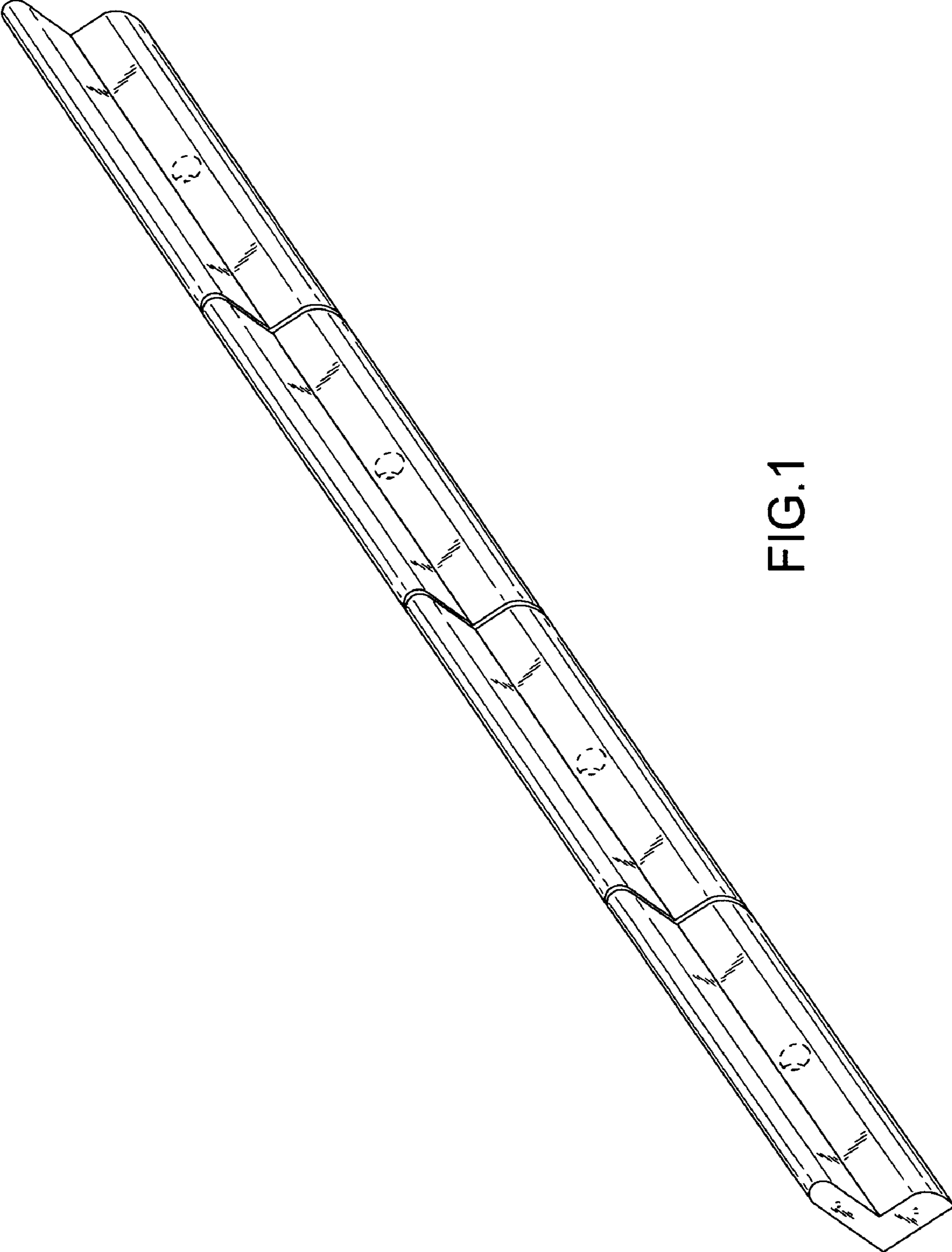

FIG.1

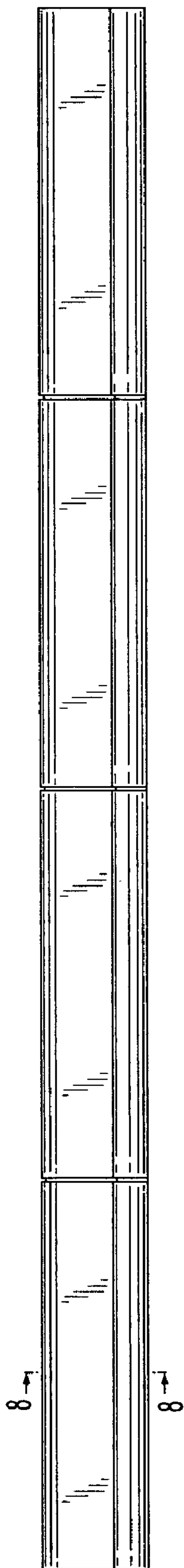

FIG. 2

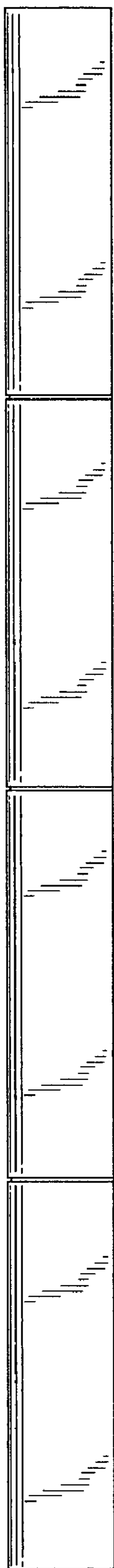

FIG. 3



FIG. 4



FIG. 5



FIG. 6



FIG. 7

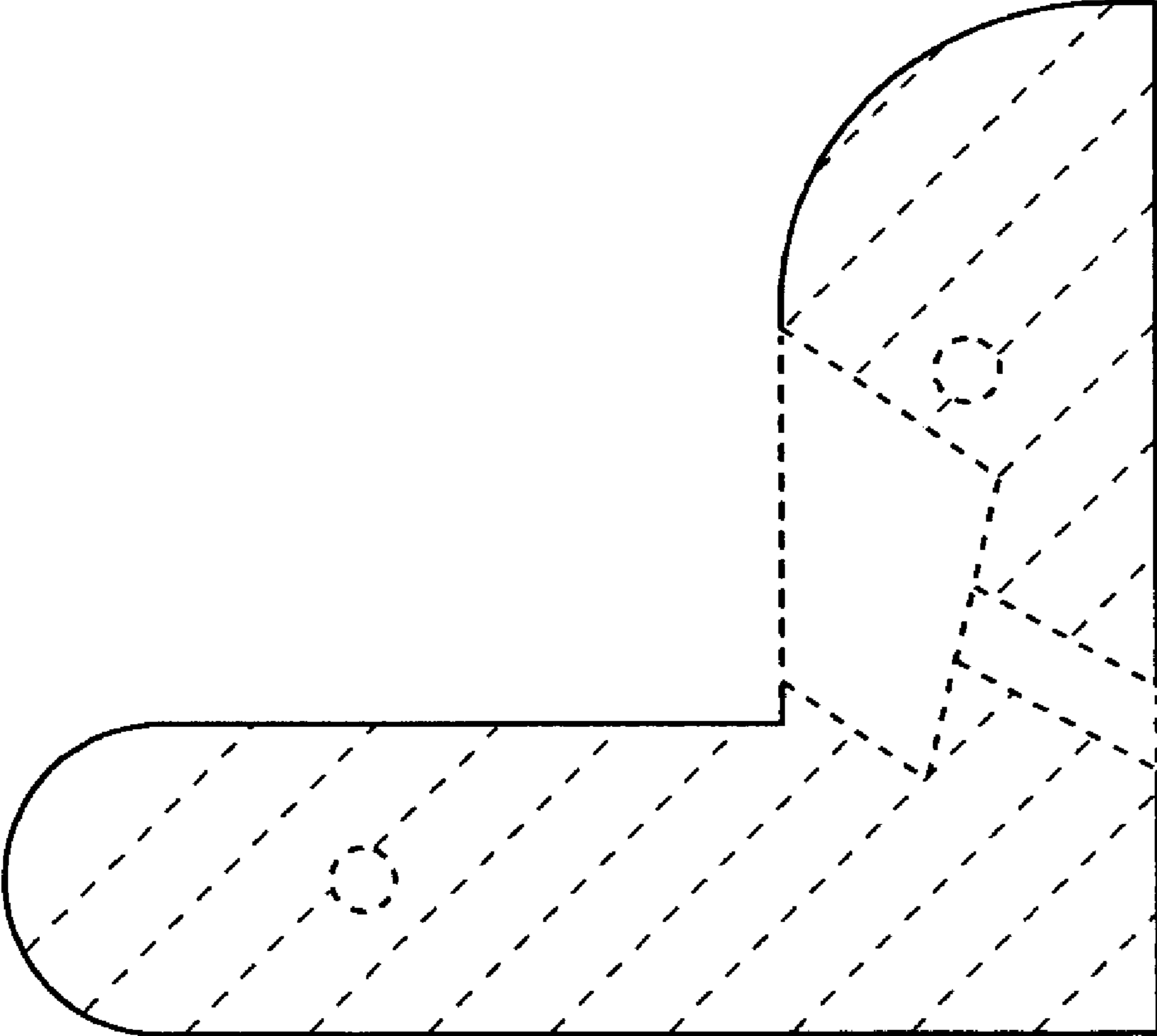

FIG.8