



US00D654104S

(12) **United States Design Patent**
Fitzpatrick et al.

(10) **Patent No.:** **US D654,104 S**
(45) **Date of Patent:** **** Feb. 14, 2012**

(54) **MECHANIZED PLASMA TORCH**

(75) Inventors: **Adam Fitzpatrick**, East Andover, NH (US); **Jonathan Mather**, Cornish, NH (US)

(73) Assignee: **Hypertherm, Inc.**, Hanover, NH (US)

(**) Term: **14 Years**

(21) Appl. No.: **29/357,891**

(22) Filed: **Mar. 18, 2010**

(51) **LOC (9) Cl.** **15-09**

(52) **U.S. Cl.** **D15/144**

(58) **Field of Classification Search** D6/524;
D15/139, 144-144.2; D23/223, 263, 373;
219/121.44-121.5; 313/231.31

See application file for complete search history.

(56) **References Cited**

U.S. PATENT DOCUMENTS

D365,345 S *	12/1995	Carkhuff	D15/144
D527,401 S *	8/2006	Mizuno et al.	D15/144
D582,950 S *	12/2008	Yamaguchi et al.	D15/144
D582,951 S *	12/2008	Yamaguchi et al.	D15/144
D636,002 S *	4/2011	Bruckner et al.	D15/144

OTHER PUBLICATIONS

Hypertherm, Inc., "HyPerformance Plasma HPR400_{XD}" Brochure, Nov. 2008 (4 pages).
Hypertherm, Inc., "HyPerformance Plasma HPR130" Brochure, Nov. 2007 (4 pages).

(Continued)

Primary Examiner — Patricia Palasik

(74) *Attorney, Agent, or Firm* — Proskauer Rose LLP

(57) **CLAIM**

The ornamental design for a mechanized plasma torch, as shown and described.

DESCRIPTION

FIG. 1 is a side view of an embodiment of a mechanized plasma torch having the new design and includes a retaining cap, a shield, and an extended torch mount all shown in broken lines, with the torch mount shown with lines broken away to indicate no particular length;

FIG. 2 is a another side view of the mechanized plasma torch of FIG. 1 in which the environment includes a retaining cap, a shield, and an extended torch mount shown in broken lines, with the torch mount shown with lines broken away to indicate no particular length in an alternate condition of use;

FIG. 3. is a side view of the mechanized plasma torch of FIG. 1 in which the environment includes a retaining cap and shield and does not include a torch mount;

FIG. 4 is a perspective view of the embodiment of a mechanized plasma torch shown in FIG. 3 in which the environment includes a retaining cap and shield shown in broken lines and does not include a torch mount;

FIG. 5 is a bottom view of the embodiment of a mechanized plasma torch shown in FIG. 4;

FIG. 6 is a top view of the embodiment of a mechanized plasma torch shown in FIG. 4;

FIG. 7 is a side view of a second embodiment of a mechanized plasma torch having the new design in which the environment does not include a torch mount, retaining cap or shield,

FIG. 8 is a perspective view of the embodiment of a mechanized plasma torch shown in FIG. 7 in which the environment does not include a torch mount, retaining cap or shield;

FIG. 9 is a bottom view of the embodiment of a mechanized plasma torch shown in FIG. 8; and,

FIG. 10 is a top view of the embodiment of a mechanized plasma torch shown in FIG. 8.

The dotted and/or broken lines depict environmental features, or the character or contour of the surfaces represented and are not a part of the claimed design.

1 Claim, 3 Drawing Sheets

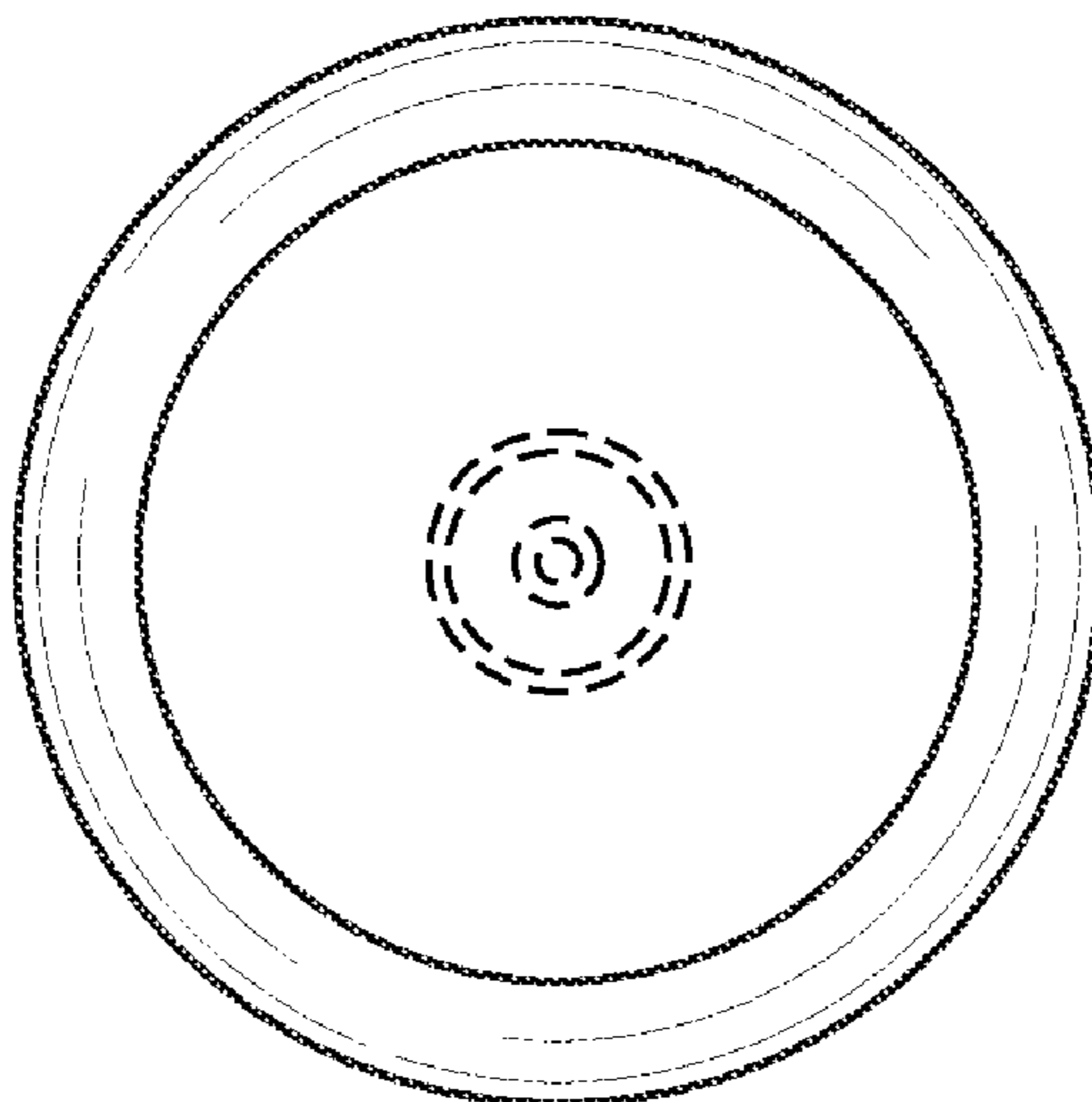

OTHER PUBLICATIONS

Hypertherm, Inc., "HyPerformance Plasma HPR400_{XD}" Brochure,
Aug. 2009 (2 pages).

Thermacut Product Catalog (*date uncertain*) (160 pages), Mar. 2010.

* cited by examiner

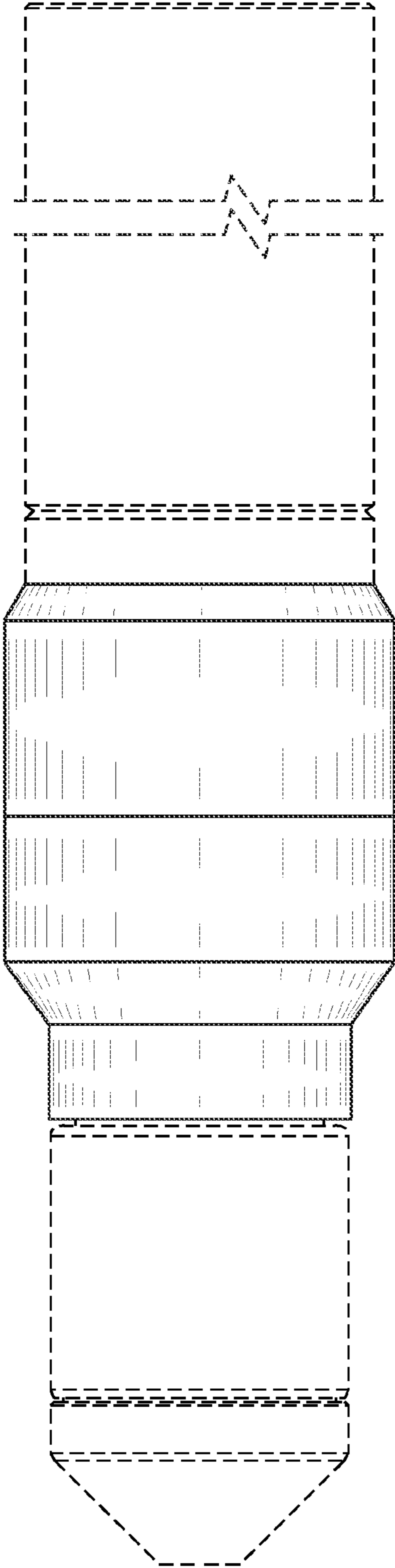

FIG. 1

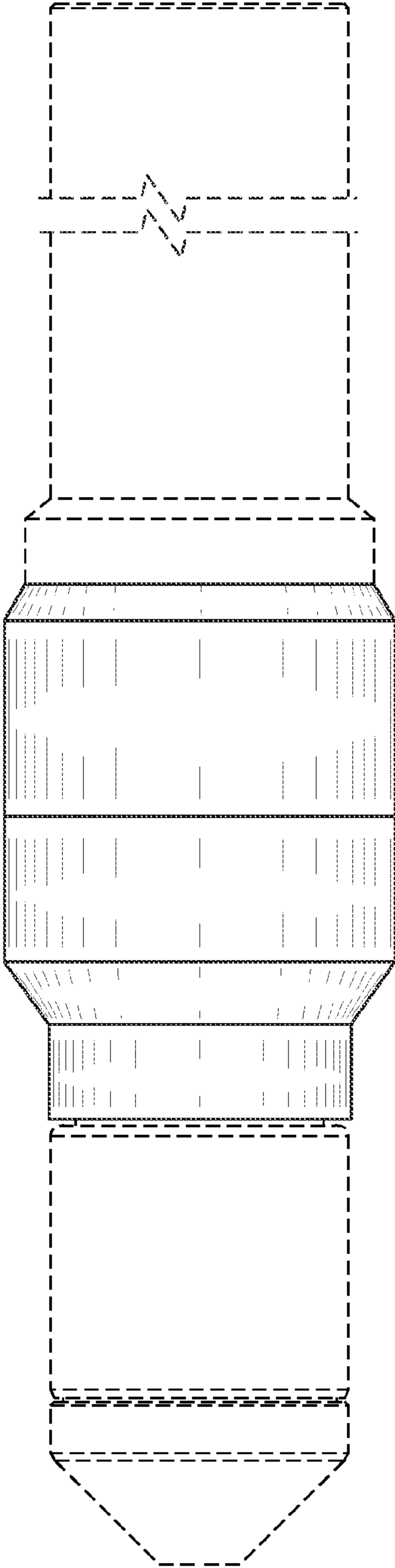

FIG. 2

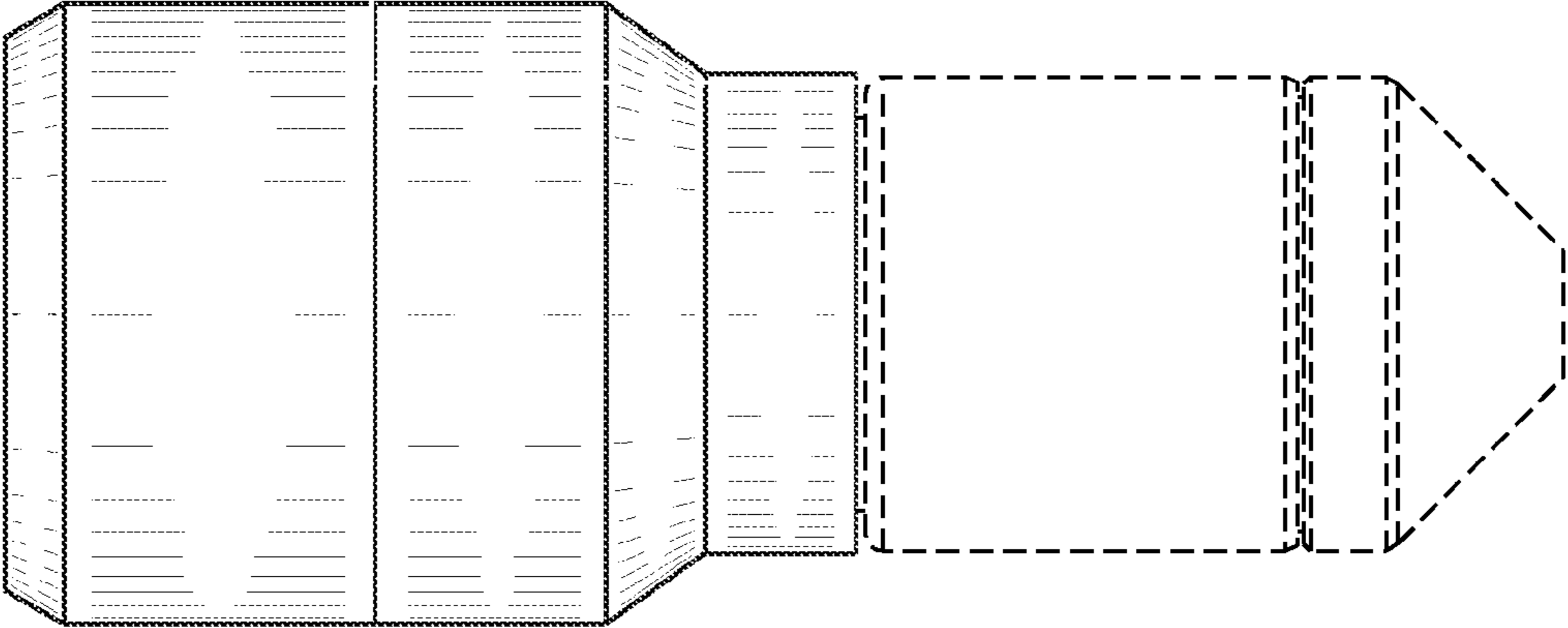

FIG. 3

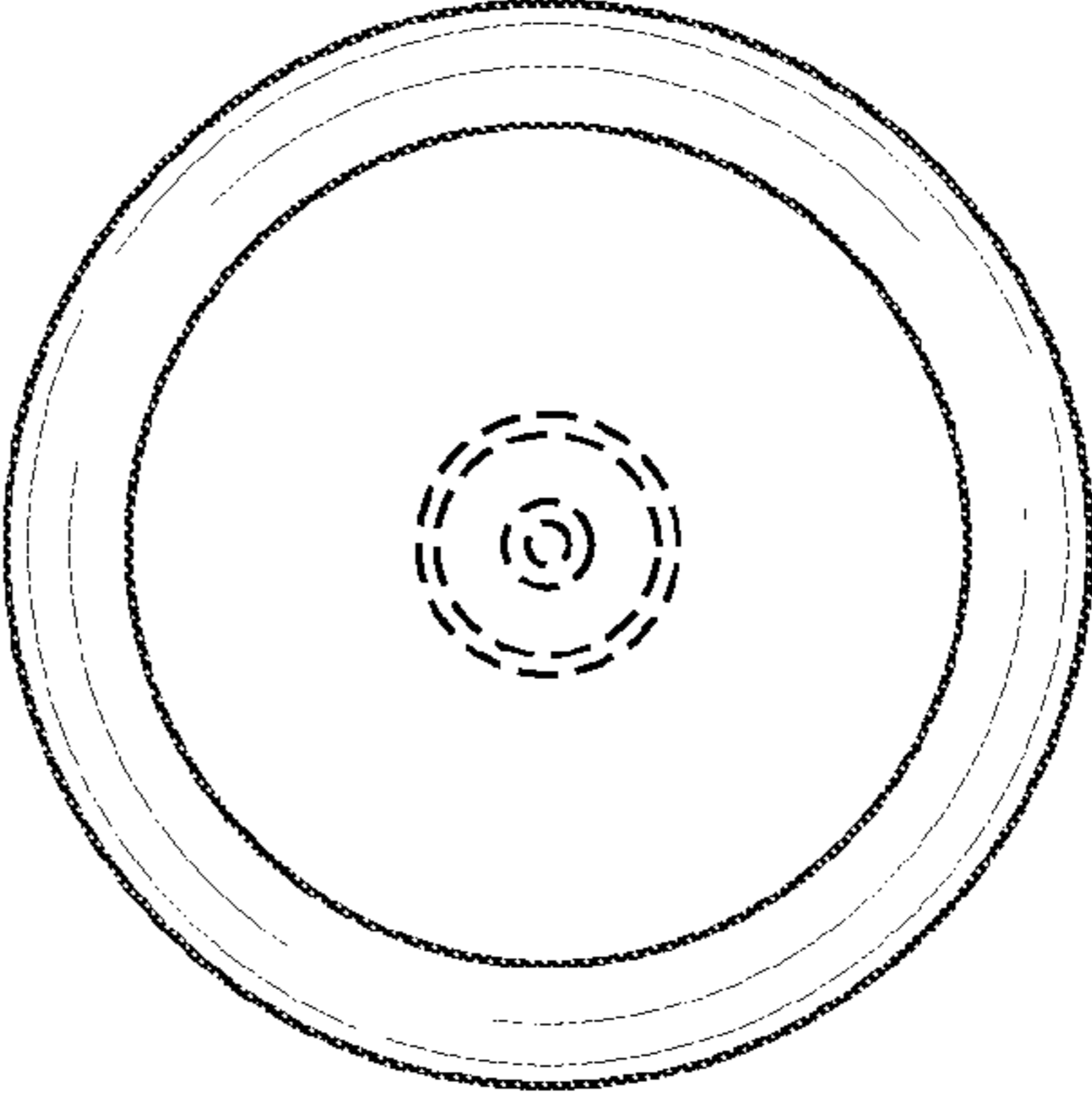

FIG. 5

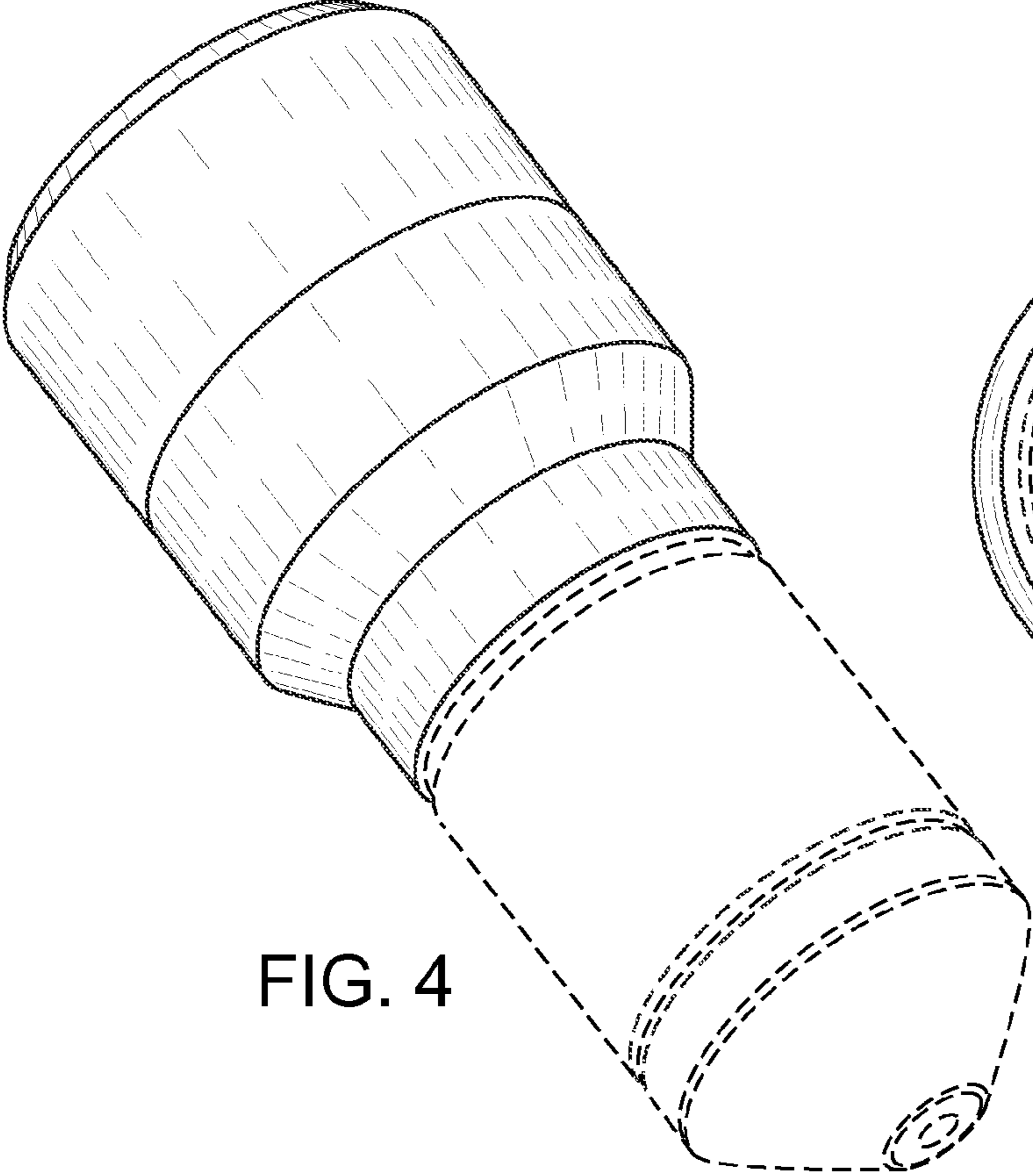

FIG. 4

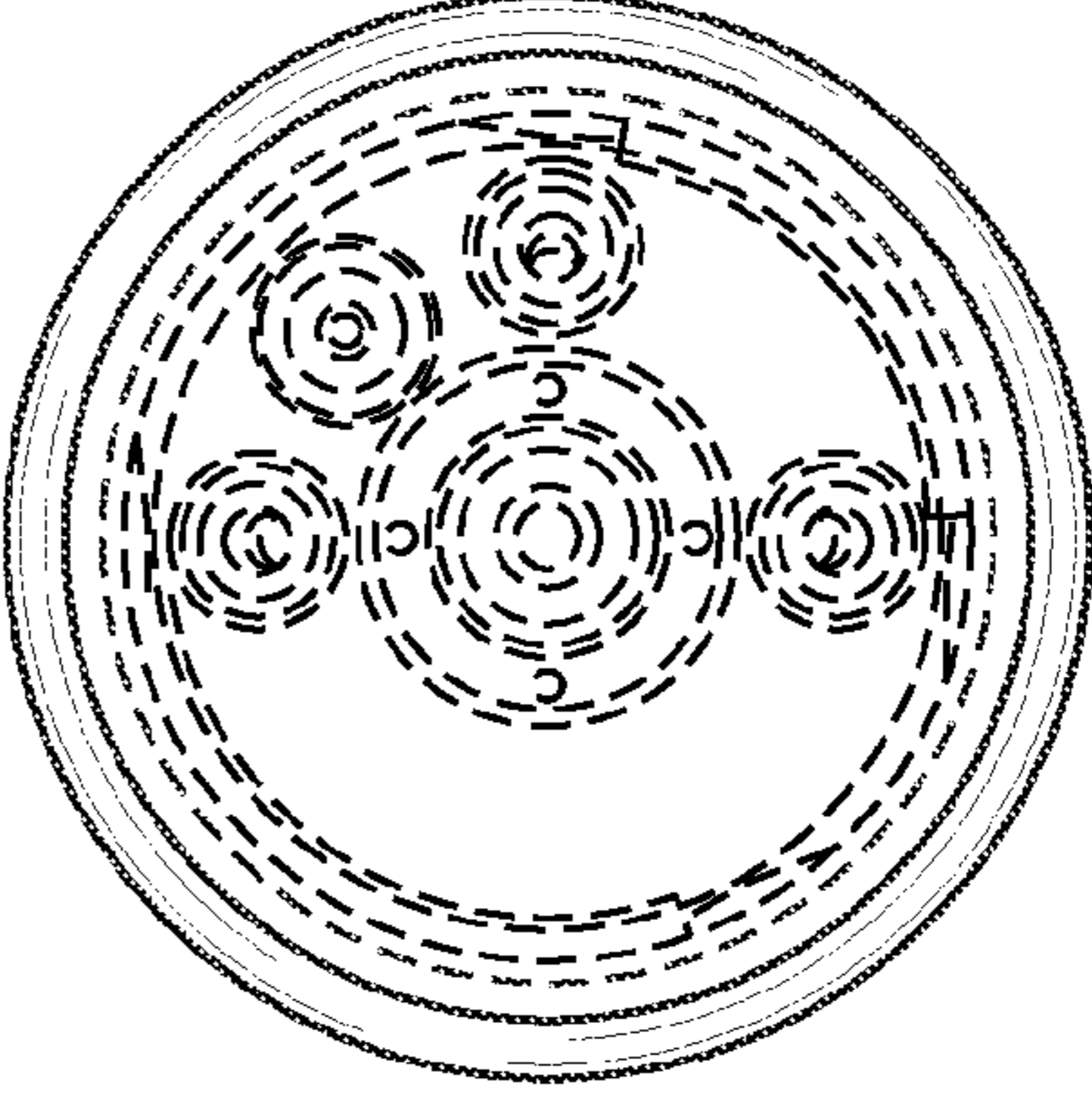

FIG. 6

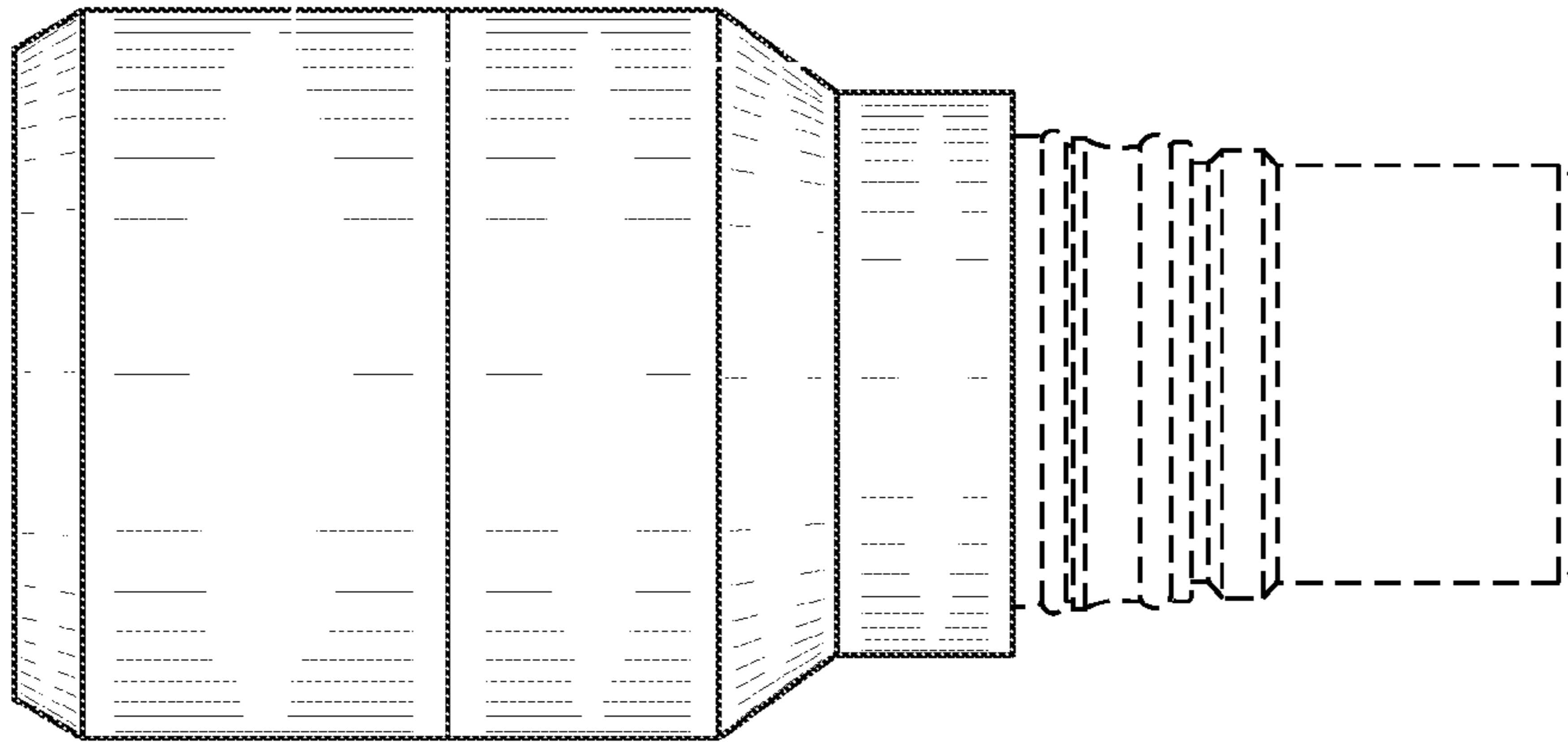

FIG. 7

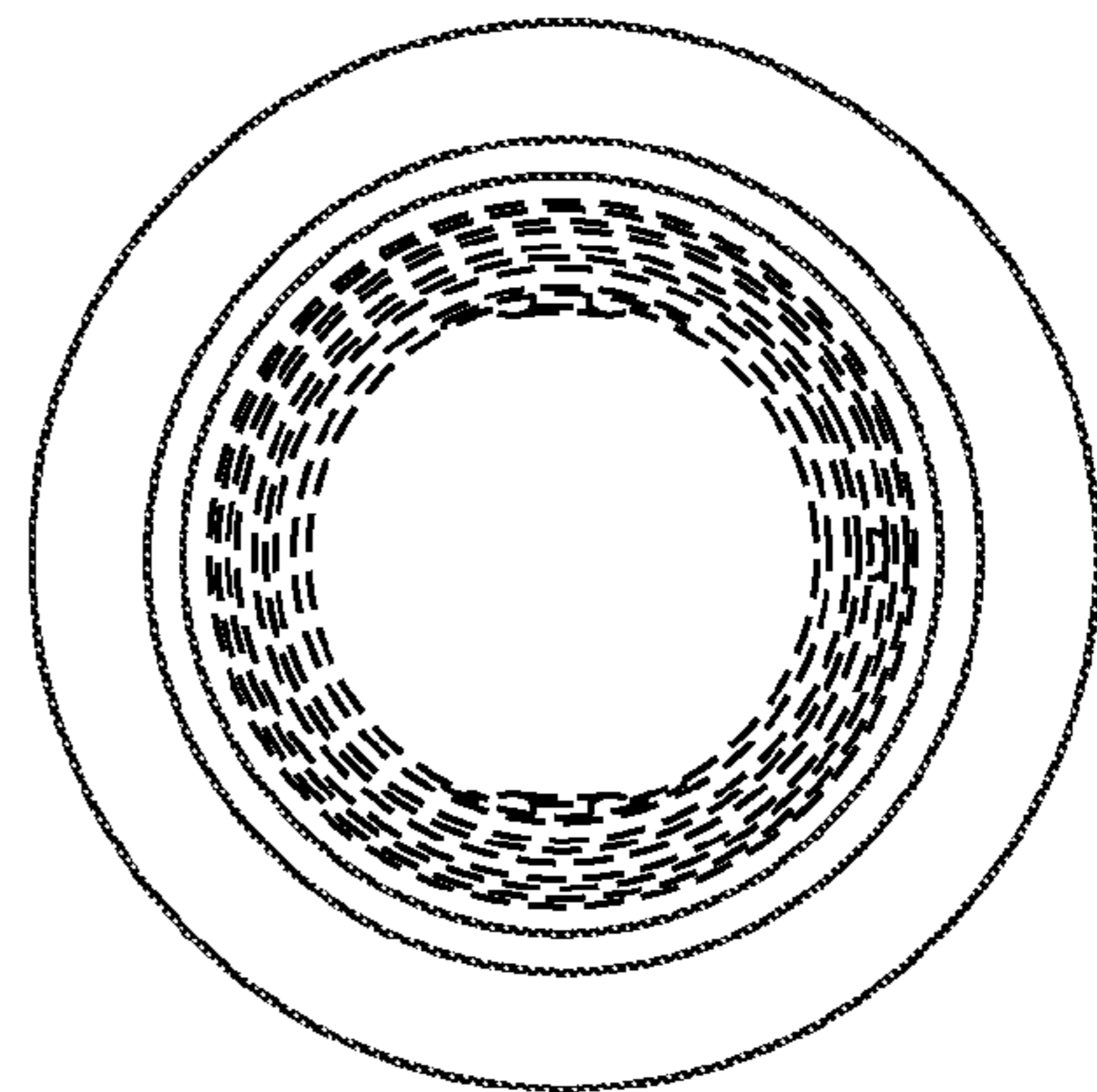

FIG. 9

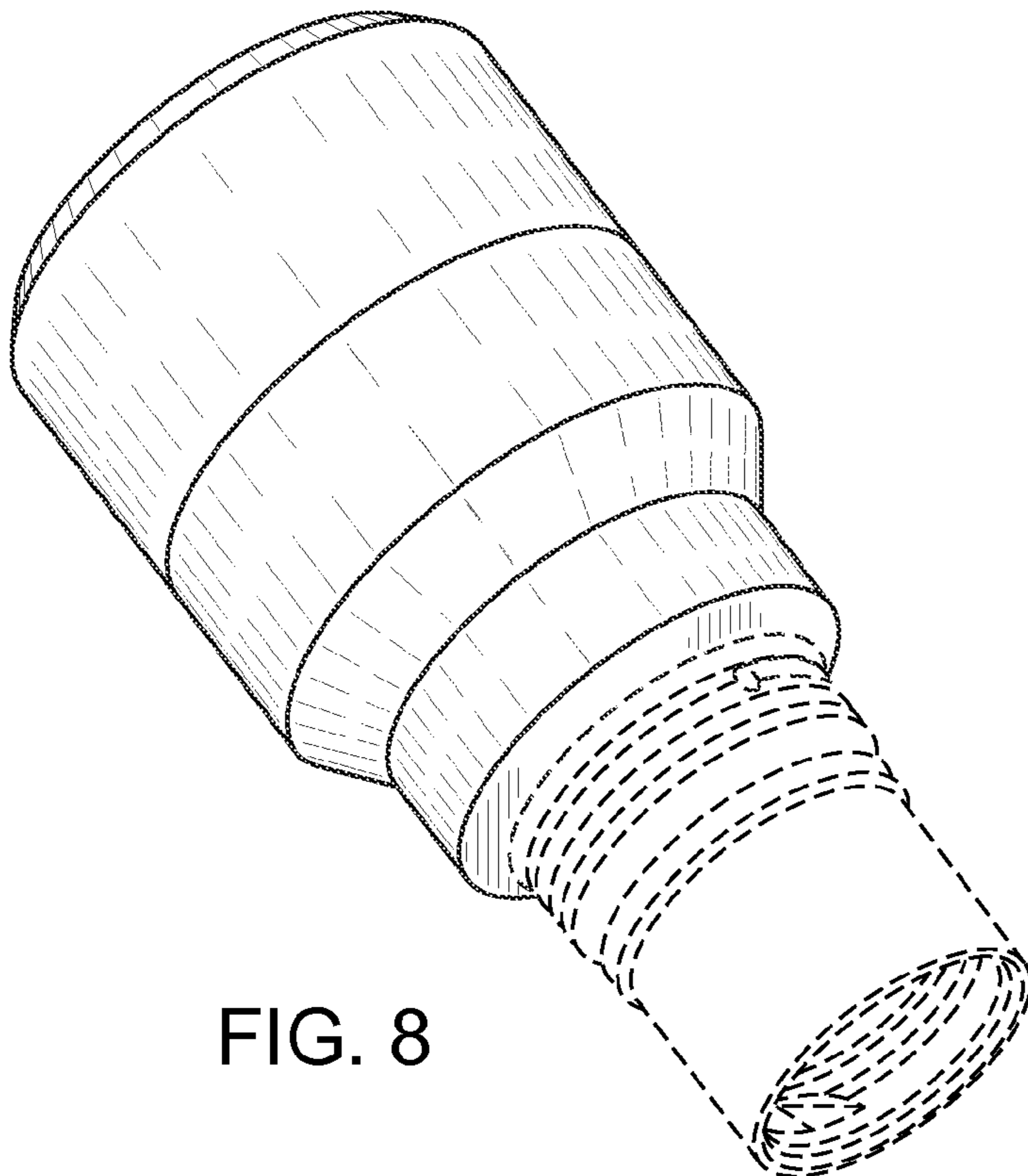

FIG. 8

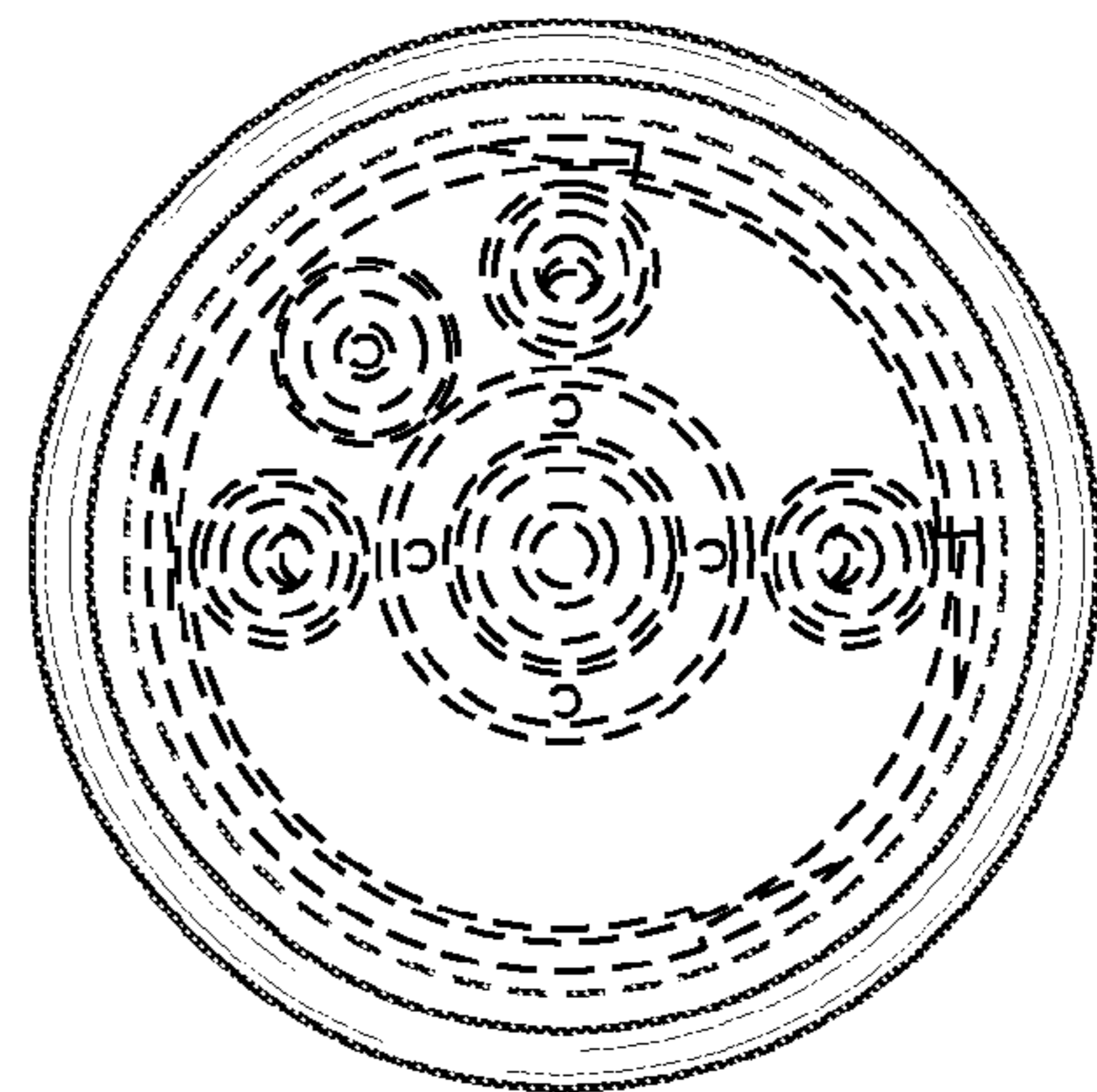

FIG. 10