



US00D654070S

(12) **United States Design Patent**  
**Silva et al.**

(10) **Patent No.:** **US D654,070 S**

(45) **Date of Patent:** **\*\* Feb. 14, 2012**

(54) **AUDIO COMPONENT FRONT FACE**

D496,031 S \* 9/2004 Ma et al. .... D14/257  
D532,006 S \* 11/2006 Kim ..... D14/258  
D566,701 S \* 4/2008 Quilling, II ..... D14/258

(75) Inventors: **Jose Jorge Silva**, Osceola, IN (US);  
**Stephen Clay**, Elkhart, IN (US); **Dai Zhi Hua**, Shenzhen (CN); **Andrew Flint**,  
Osceola, IN (US)

\* cited by examiner

*Primary Examiner* — Nanda Bondade

(73) Assignee: **Harman International Industries, Incorporated**, Northridge, CA (US)

(74) *Attorney, Agent, or Firm* — Plumsea Law Group, LLC

(\*\*) Term: **14 Years**

(57) **CLAIM**

We claim the ornamental design for an audio component front face, as shown and described.

(21) Appl. No.: **29/381,417**

(22) Filed: **Dec. 20, 2010**

**DESCRIPTION**

(51) **LOC (9) Cl.** ..... **14-01**

(52) **U.S. Cl.** ..... **D14/257**

(58) **Field of Classification Search** ..... D14/496,  
D14/498-511, 167-168, 188, 197-198, 157-158;  
360/99.02, 99.07; 369/75.11, 75.21, 77.11,  
369/77.21; 720/601, 612, 619, 649, 655;  
455/344, 347-351

FIG. 1 illustrates a perspective view of an audio component front face showing the new design;  
FIG. 2 illustrates a front elevation view thereof;  
FIG. 3 illustrates a top plan view thereof;  
FIG. 4 illustrates a bottom plan view thereof;  
FIG. 5 illustrates a back elevation view thereof; and  
FIG. 6 is a left side elevation view thereof; and,  
FIG. 7 is a right side elevation view thereof.

See application file for complete search history.

The broken lines in the drawings showing the arcs, circles, ovals, lines, rectangles and features of the rear face are for illustrative purposes only and form no part of the claimed design.

(56) **References Cited**

U.S. PATENT DOCUMENTS

D131,193 S \* 1/1942 Dean ..... D14/257  
D360,419 S \* 7/1995 Weber et al. .... D14/257

**1 Claim, 6 Drawing Sheets**

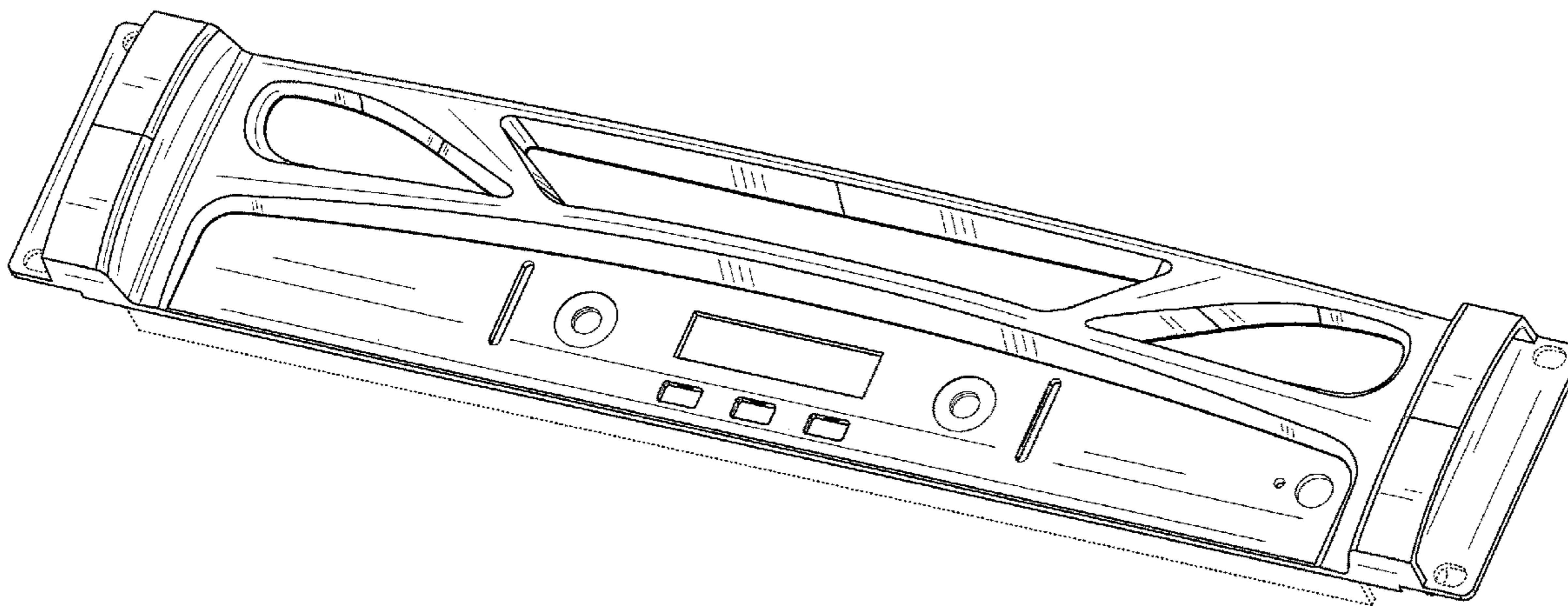

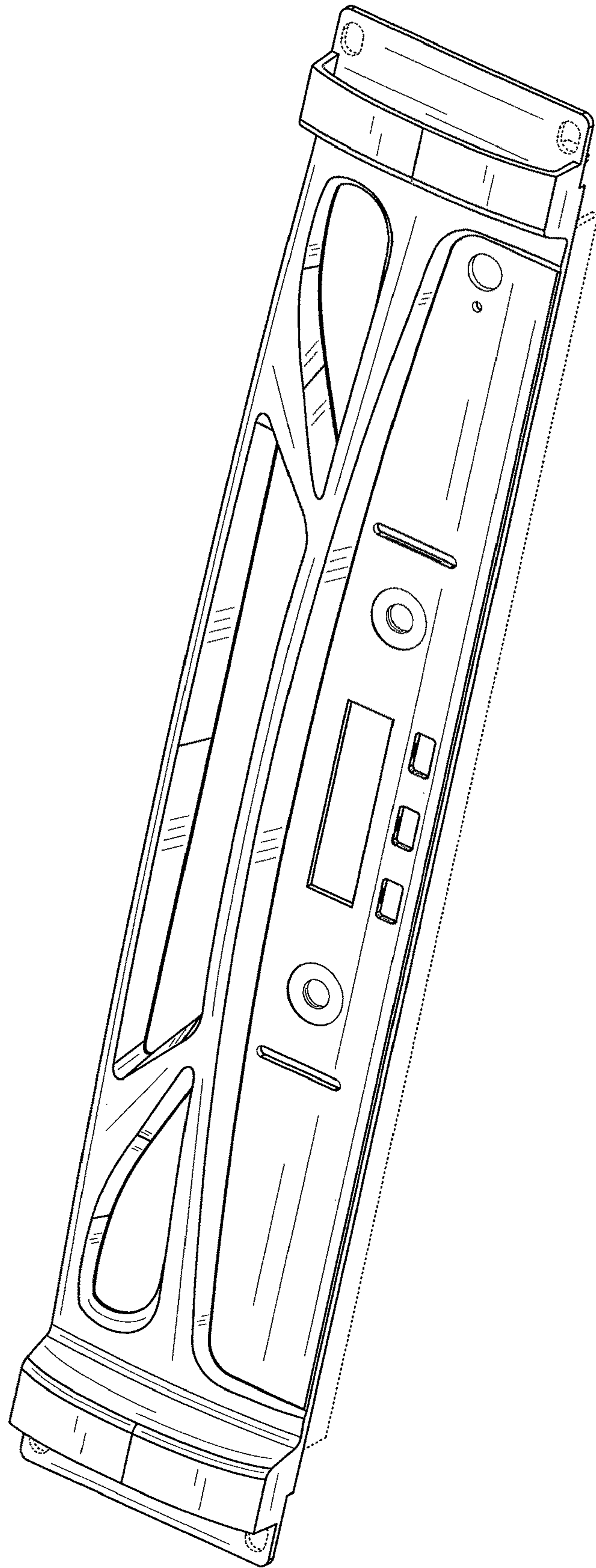

Figure 1

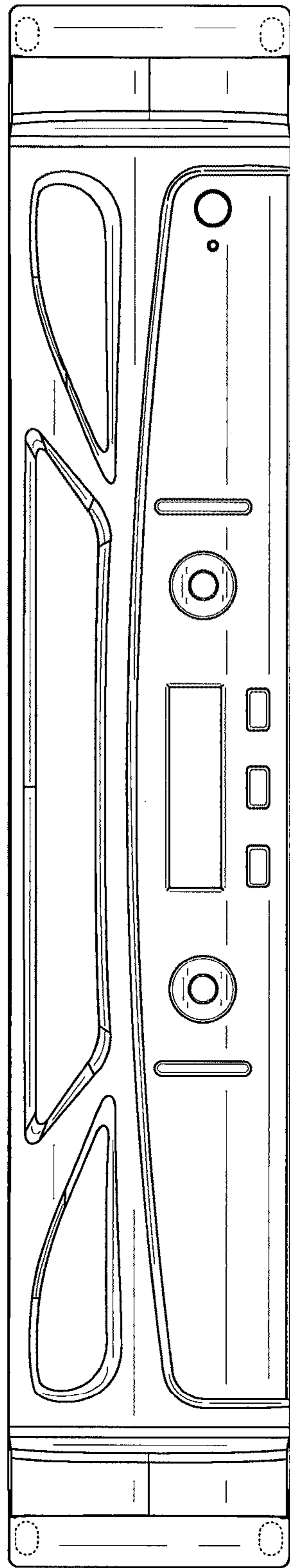

Figure 2

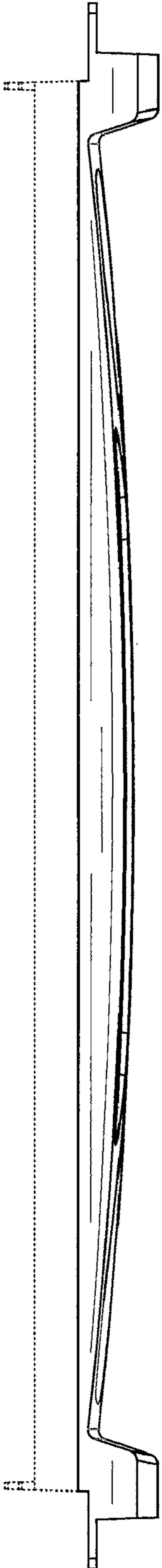

Figure 3

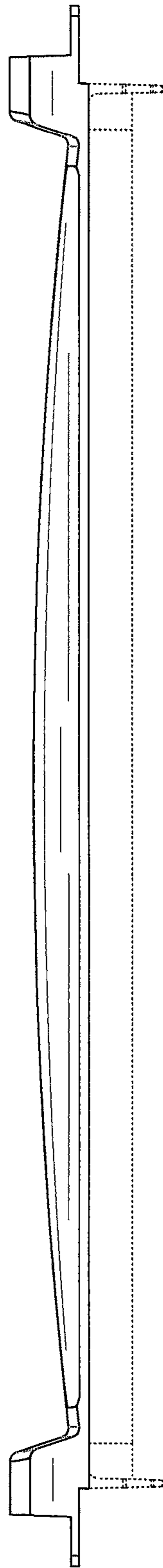

Figure 4

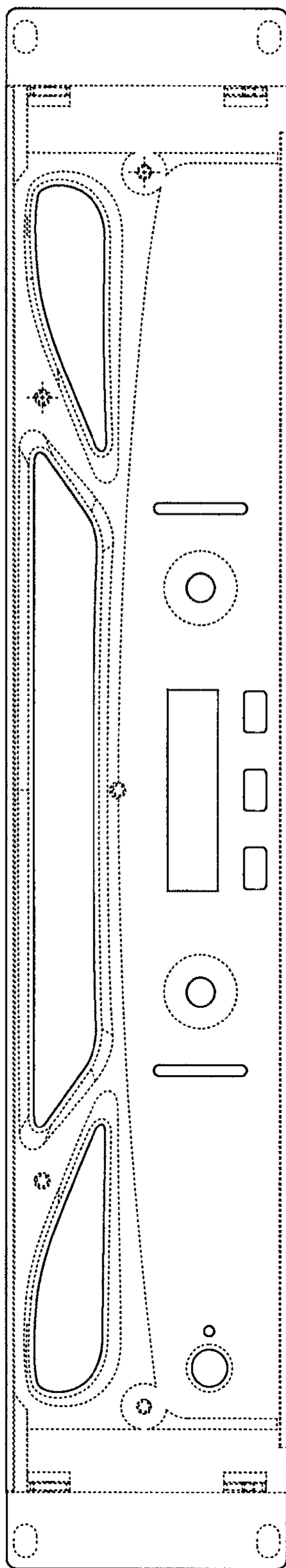

Figure 5



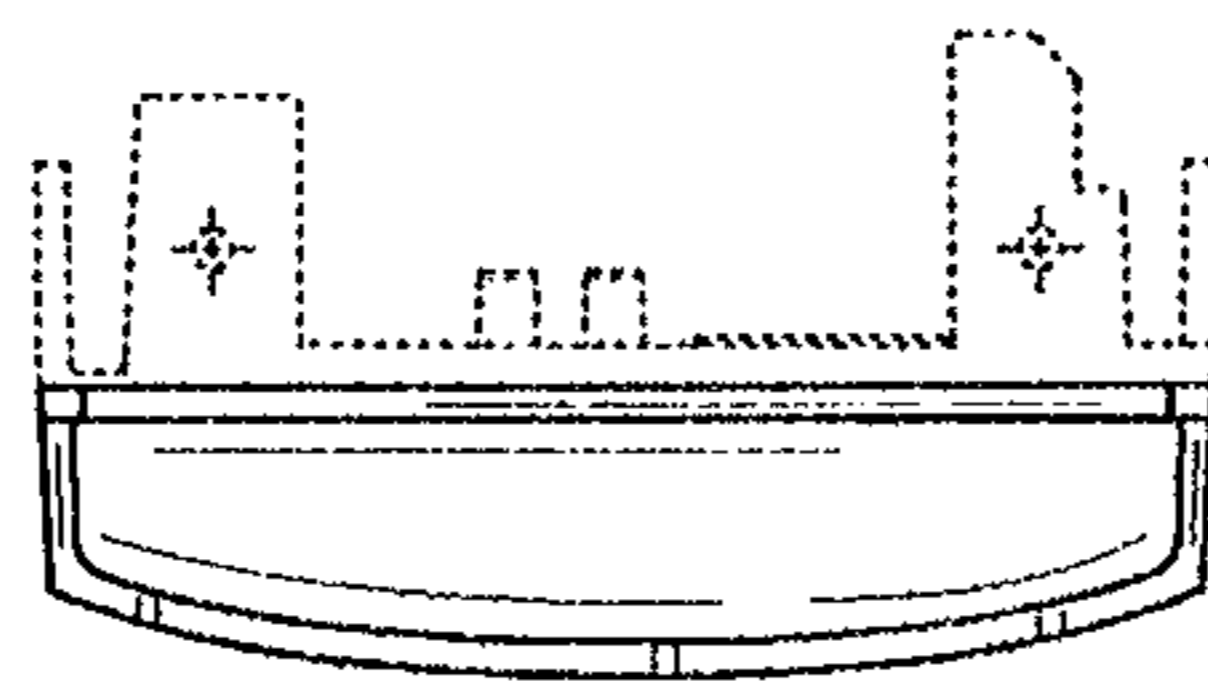

Figure 6

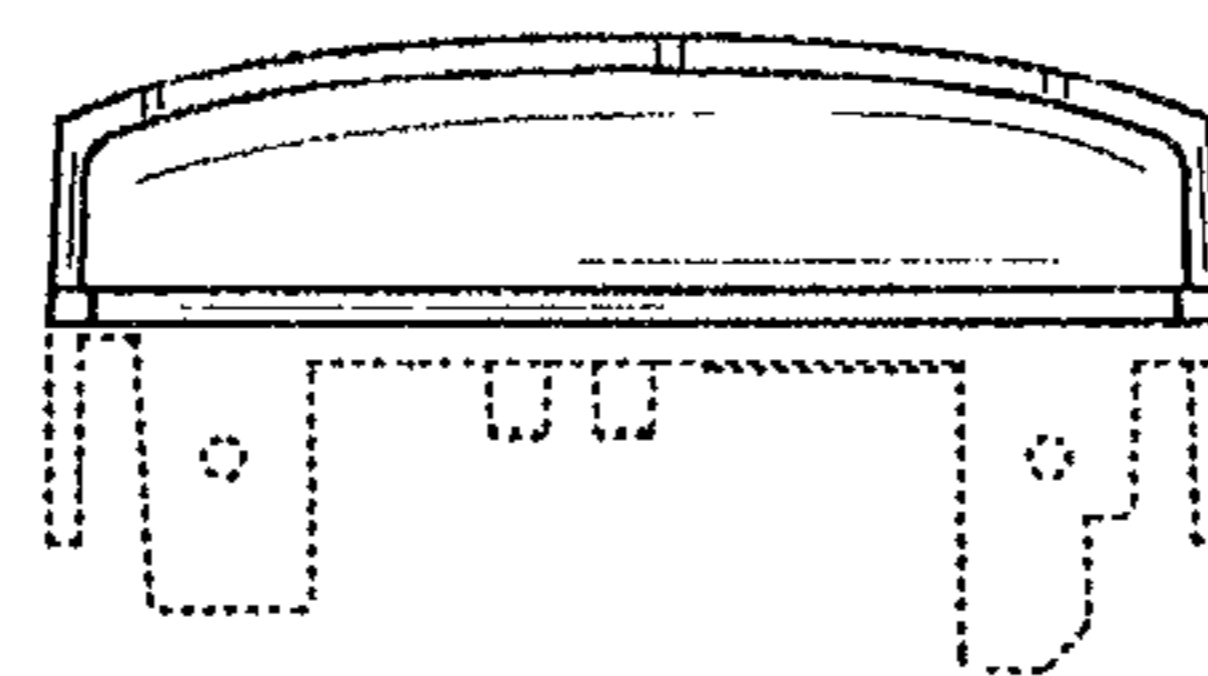

Figure 7