



US00D653993S

(12) **United States Design Patent**  
**Cohen et al.**

(10) **Patent No.:** **US D653,993 S**  
(45) **Date of Patent:** **\*\* Feb. 14, 2012**

(54) **PROMOTIONAL VEHICLE**

(75) Inventors: **Benjamin Cohen**, Brooklyn, NY (US);  
**David Hazan**, New York, NY (US)

(73) Assignee: **Bobcar Media LLP**, New York, NY  
(US)

(\*\*) Term: **14 Years**

(21) Appl. No.: **29/364,594**

(22) Filed: **Jun. 25, 2010**

**Related U.S. Application Data**

(63) Continuation-in-part of application No. 29/360,773,  
filed on Apr. 30, 2010, which is a continuation-in-part  
of application No. 12/380,989, filed on Mar. 5, 2009,  
now Pat. No. 7,942,461.

(51) **LOC (9) Cl.** ..... **12-08**

(52) **U.S. Cl.** ..... **D12/93**

(58) **Field of Classification Search** ..... D12/93,  
D12/96, 97, 99; D21/424, 434, 581; 180/89.16,  
180/89.18, 89.19; 296/183.1, 21, 24.3, 168;  
40/591, 603

See application file for complete search history.

(56) **References Cited**

**U.S. PATENT DOCUMENTS**

- 5,507,109 A \* 4/1996 Rinzler ..... 40/603
- 5,918,924 A \* 7/1999 Cowan ..... 296/21
- 5,950,173 A \* 9/1999 Perkowski ..... 705/27.1
- 6,036,250 A \* 3/2000 Glatter ..... 296/21
- 6,182,795 B1 \* 2/2001 Boerer ..... 186/52
- D466,449 S \* 12/2002 Buring et al. .... D12/93
- D466,836 S \* 12/2002 Kerouanton et al. .... D12/93
- D466,837 S \* 12/2002 Buring et al. .... D12/93
- 6,585,305 B2 \* 7/2003 Nazginov et al. .... 296/21
- 7,444,773 B2 \* 11/2008 Kolodziejczak, Sr. .... 40/591

- 7,621,576 B2 \* 11/2009 Cote ..... 296/24.3
- D614,999 S \* 5/2010 Schneider ..... D12/93
- 7,942,461 B2 \* 5/2011 Cohen et al. .... 296/21

\* cited by examiner

*Primary Examiner* — Melody N Brown

(74) *Attorney, Agent, or Firm* — Goldberg Cohen LLP

(57) **CLAIM**

I claim the ornamental design for a promotional vehicle, as shown and described.

**DESCRIPTION**

FIG. 1 is a perspective view of the promotional vehicle of the present invention, having panels in an open position;  
 FIG. 2 is a front view of the promotional vehicle, having panels in an open position;  
 FIG. 3 is a rear view of the promotional vehicle, having panels in an open position;  
 FIG. 4 is a left side view of the promotional vehicle, having panels in an open position;  
 FIG. 5 is a right side view of the promotional vehicle, having panels in an open position;  
 FIG. 6 is a bottom view of the promotional vehicle;  
 FIG. 7 is a perspective view of the promotional vehicle, having panels in a closed position;  
 FIG. 8 is a front view of the promotional vehicle, having panels in a closed position;  
 FIG. 9 is a rear view of the promotional vehicle, having panels in a closed position;  
 FIG. 10 is a left side view of the promotional vehicle, having panels in a closed position;  
 FIG. 11 is a right side view of the promotional vehicle, having panels in a closed position; and,  
 FIG. 12 is a top view of the promotional vehicle, having panels in an open or a closed position.

The broken lines shown throughout the drawing views are for illustrative purposes only and form no part of the claimed design.

**1 Claim, 10 Drawing Sheets**

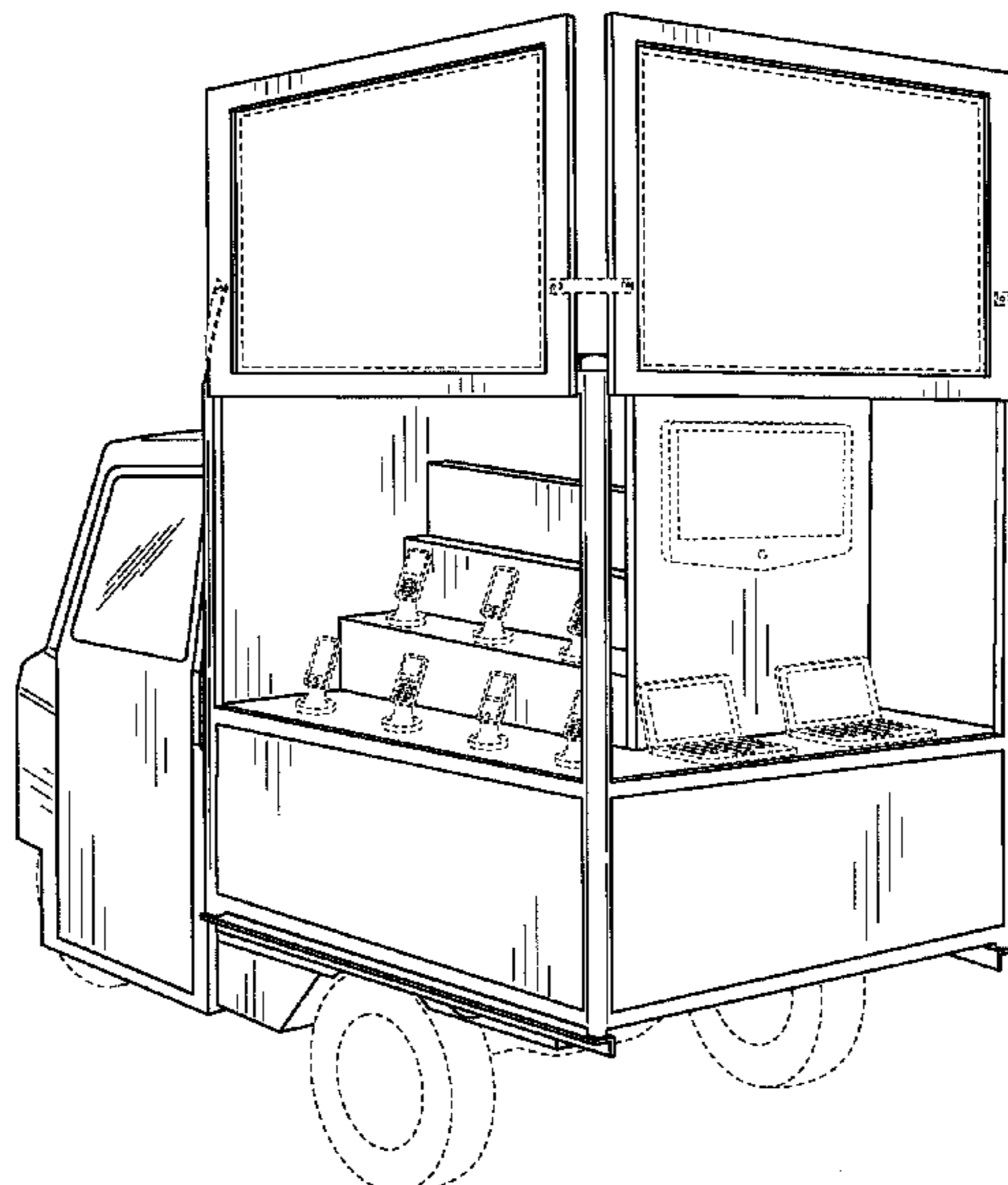

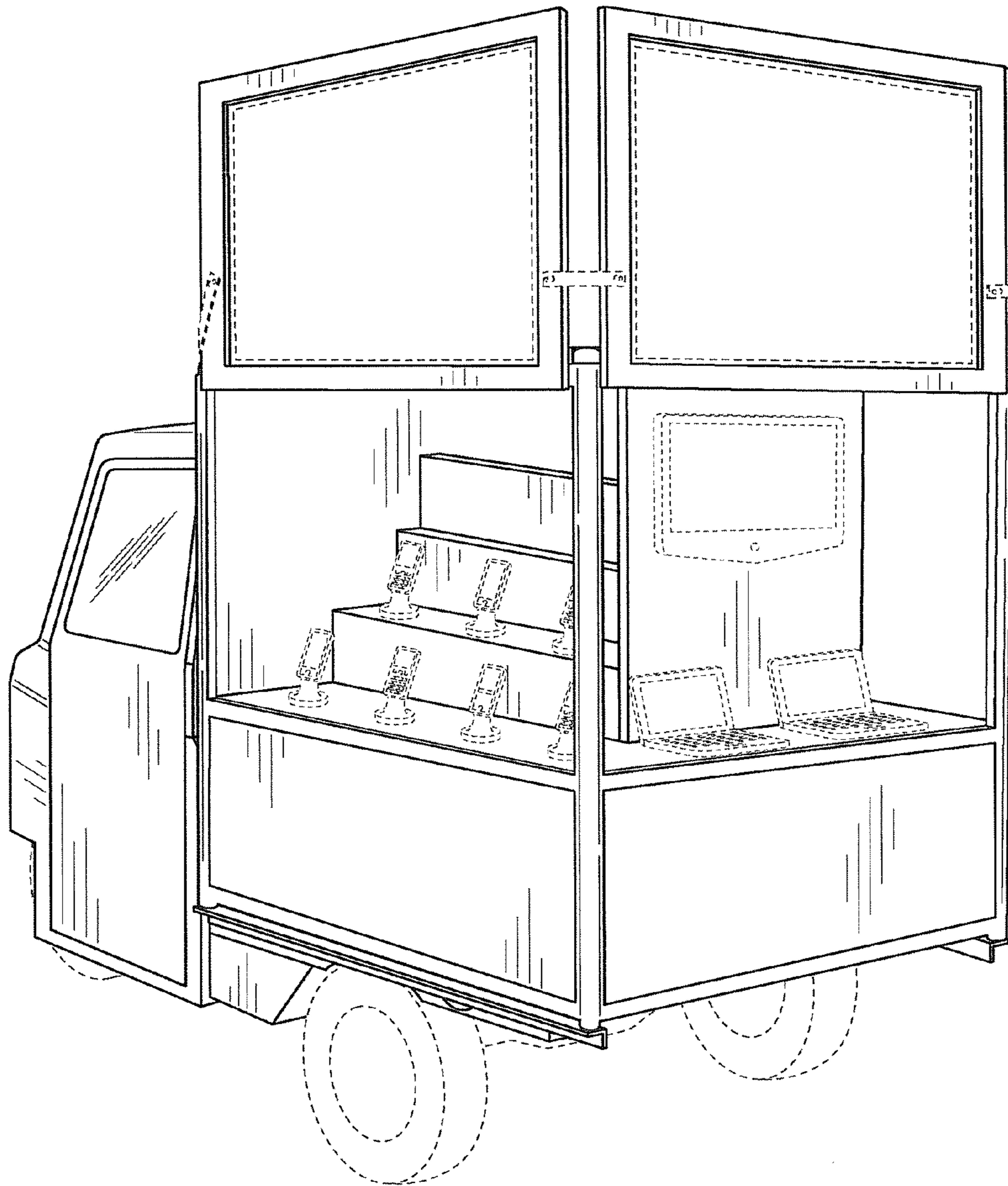

FIG. 1

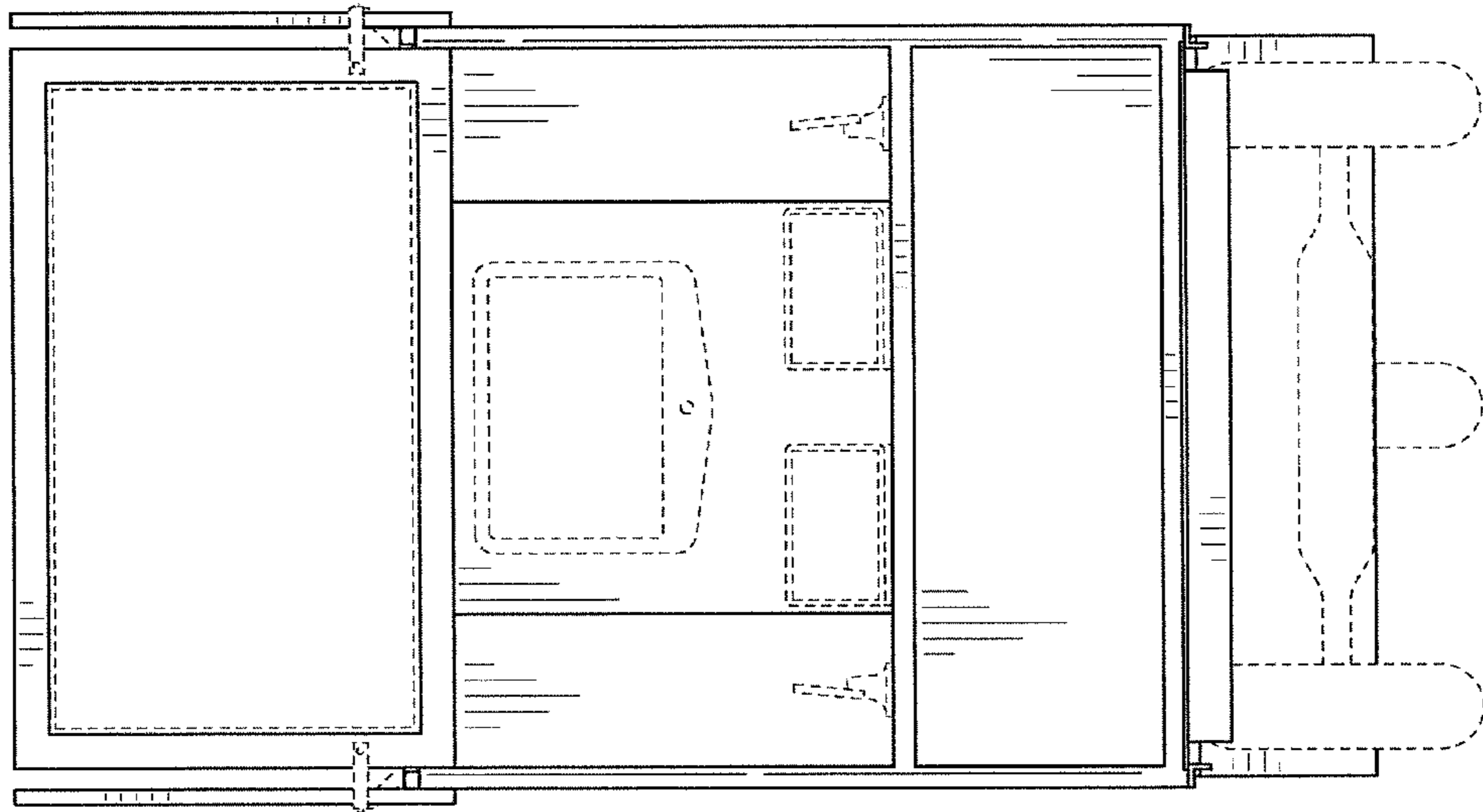

FIG. 3

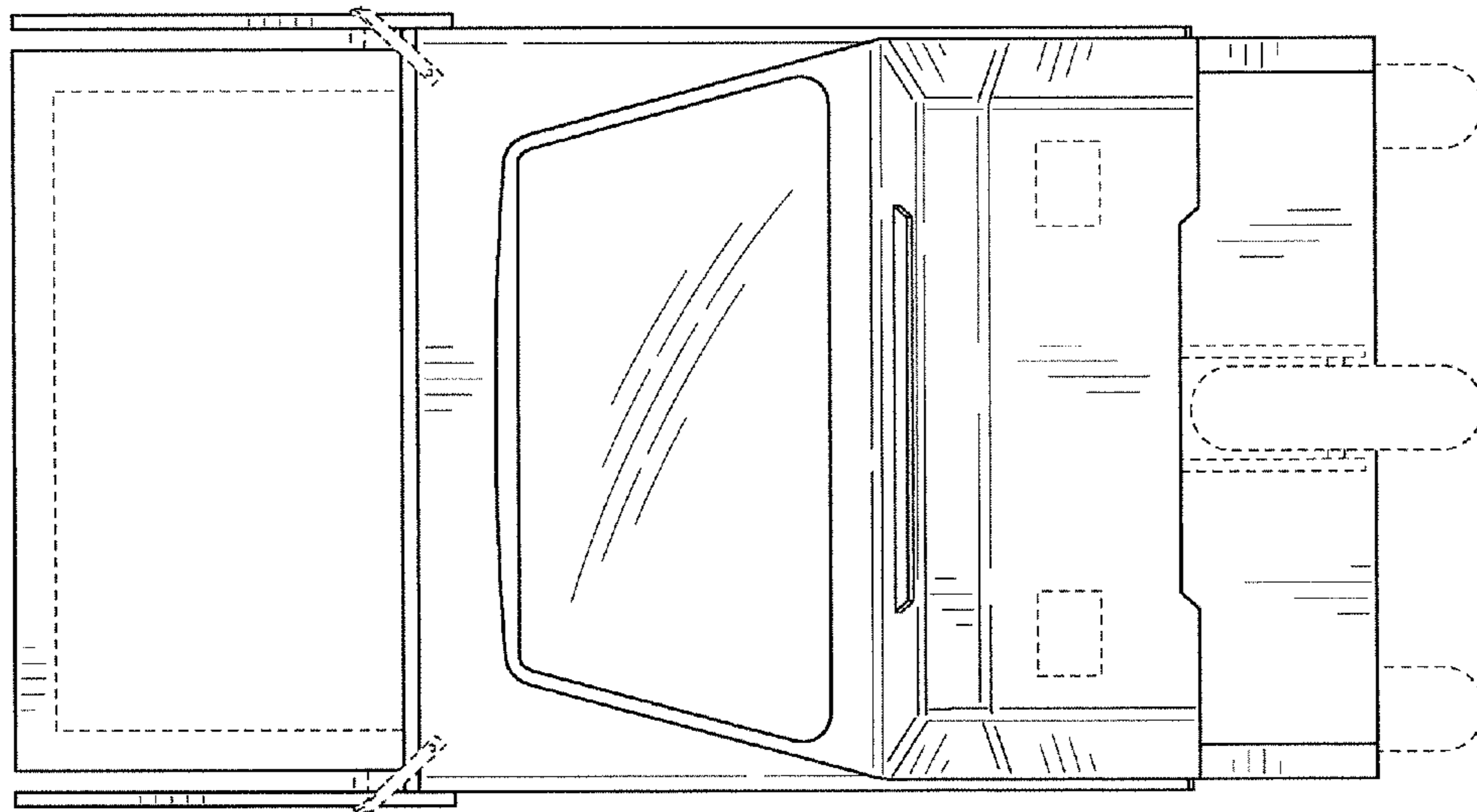

FIG. 2

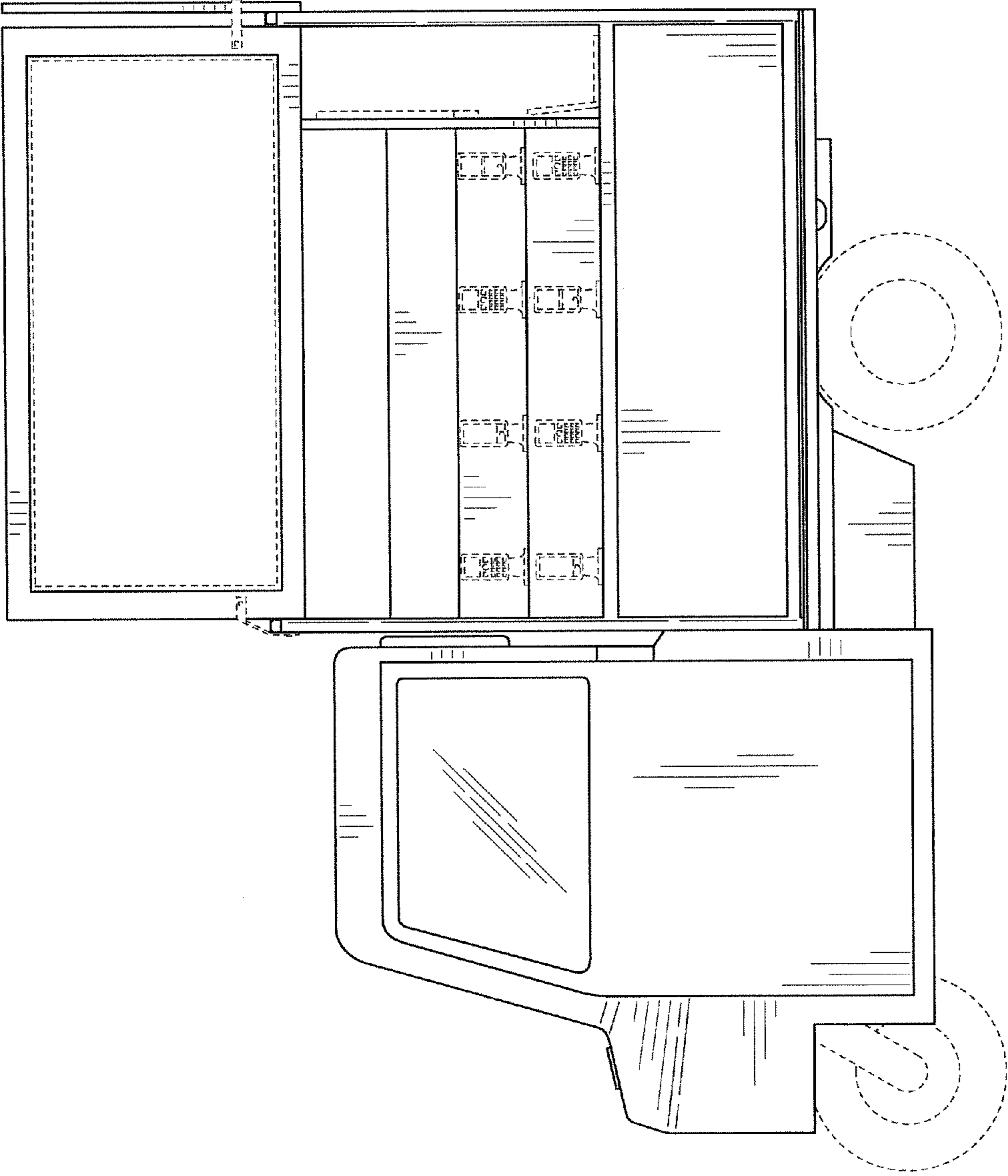

FIG. 4

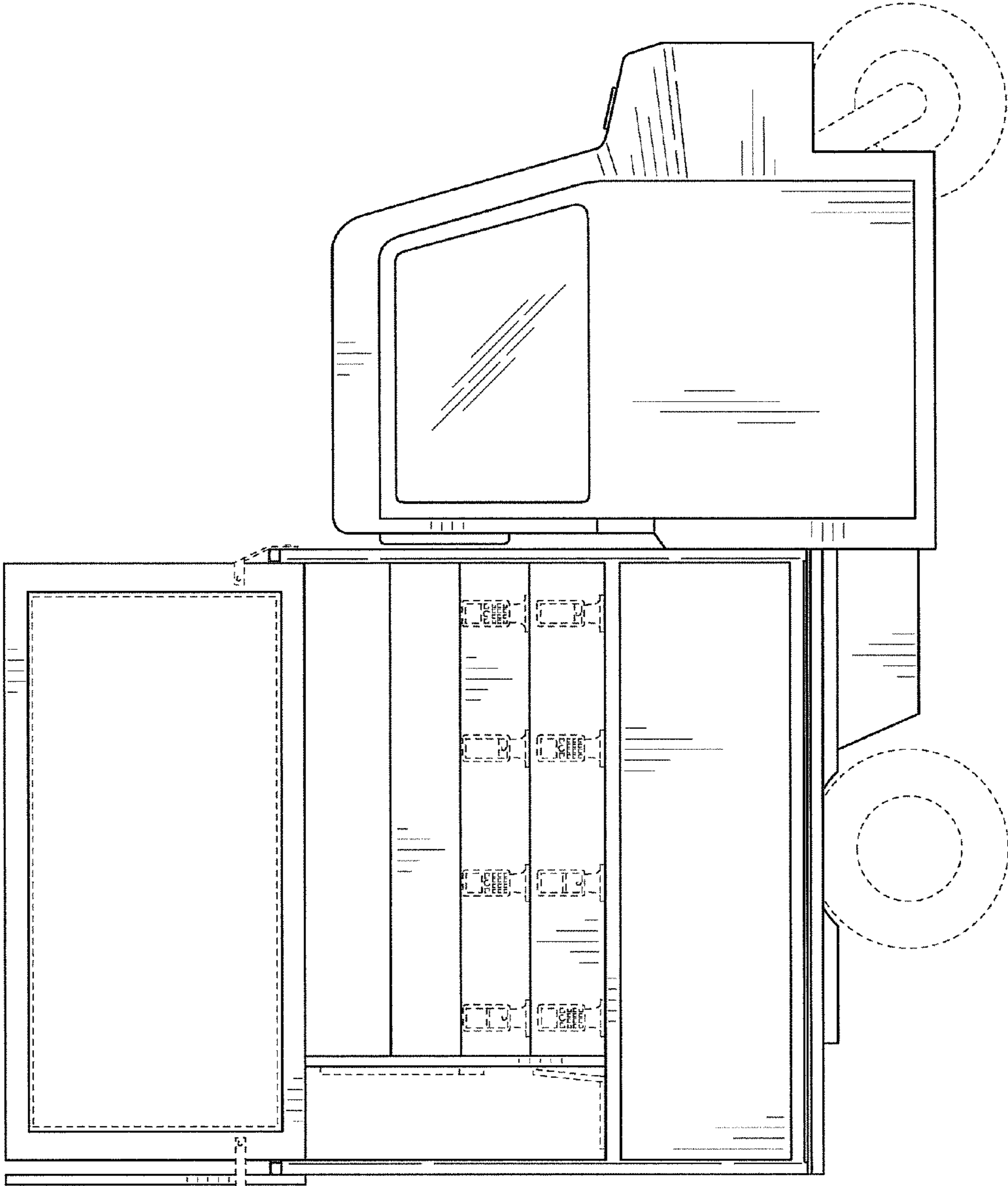

FIG. 5

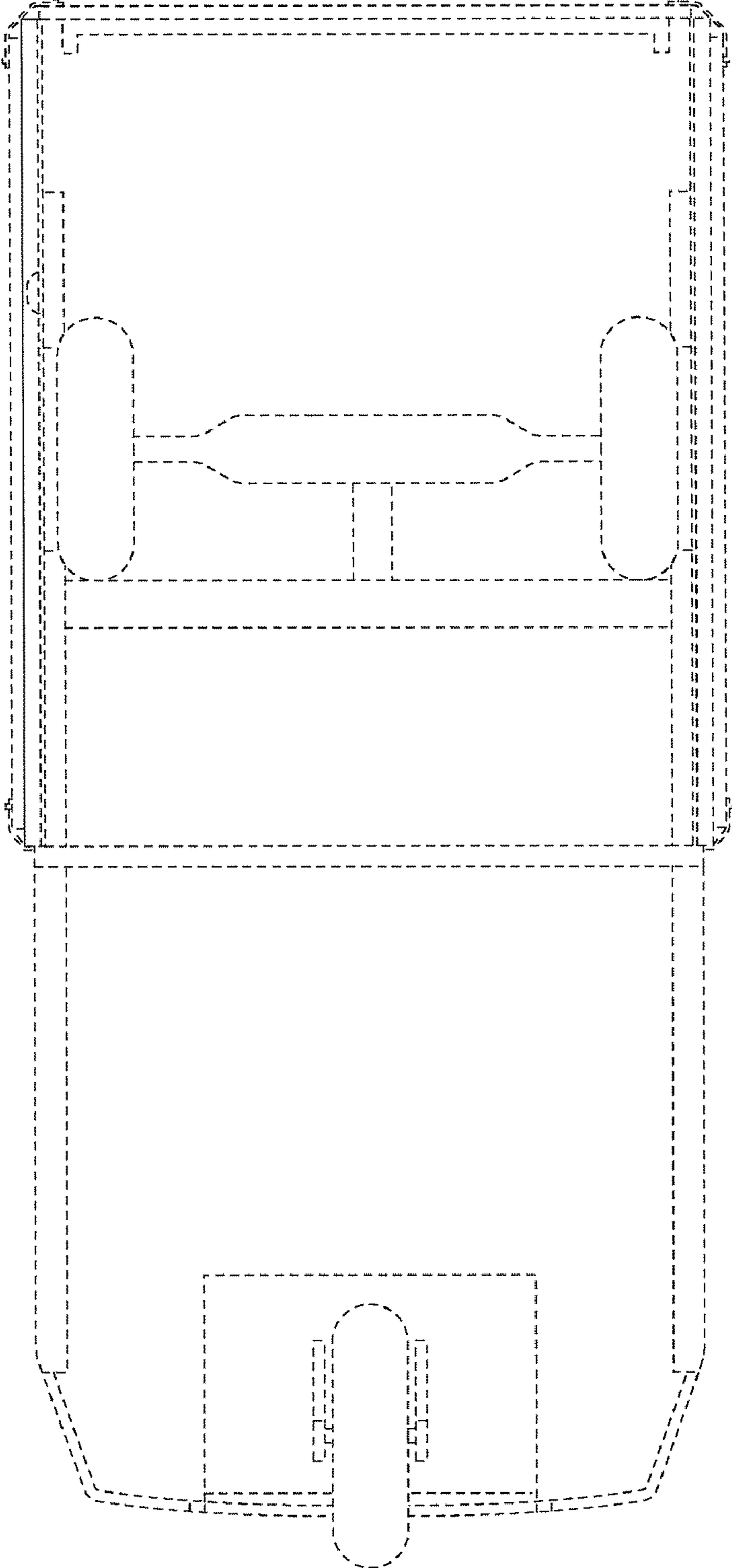

FIG. 6

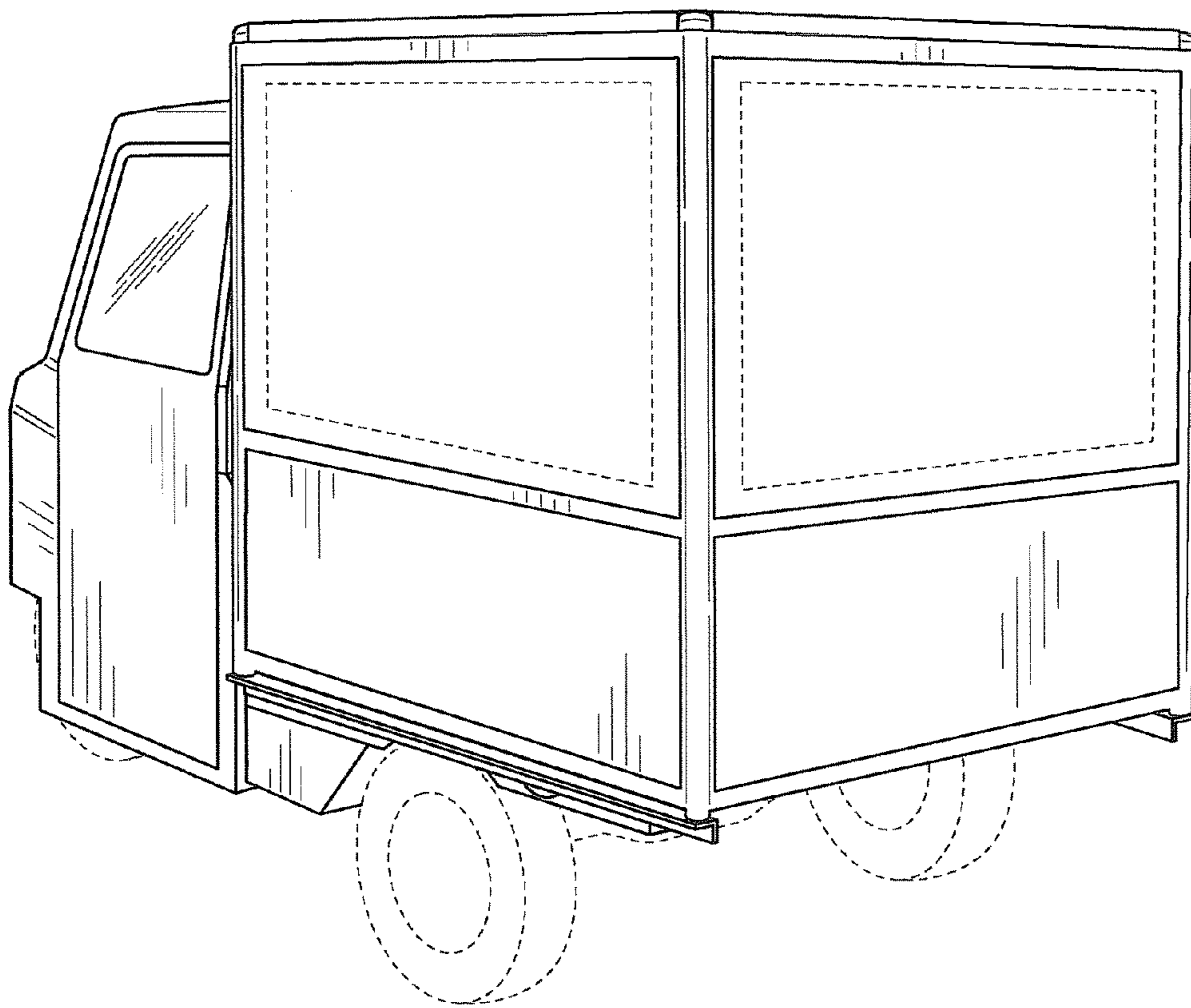

FIG. 7

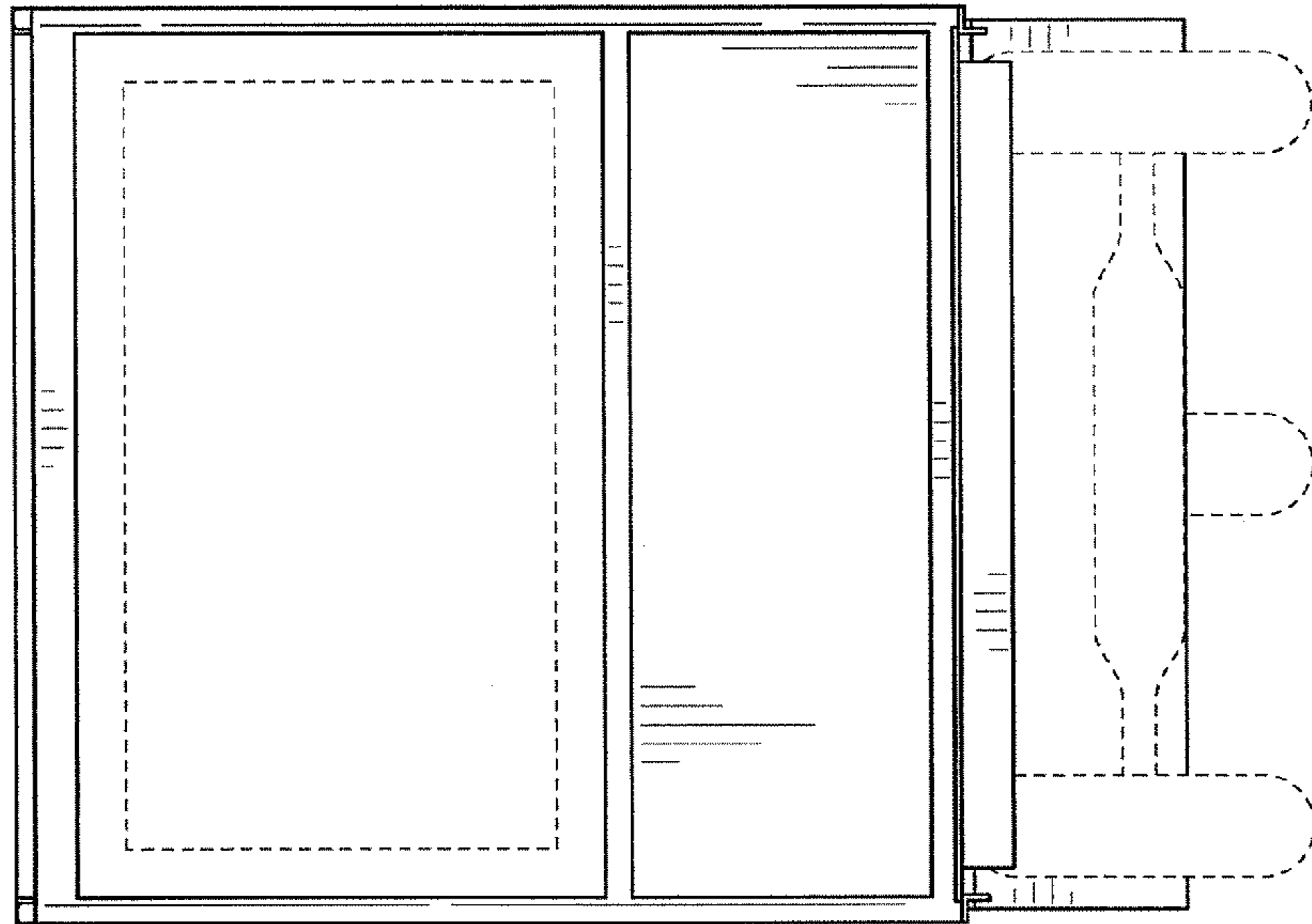

FIG. 9

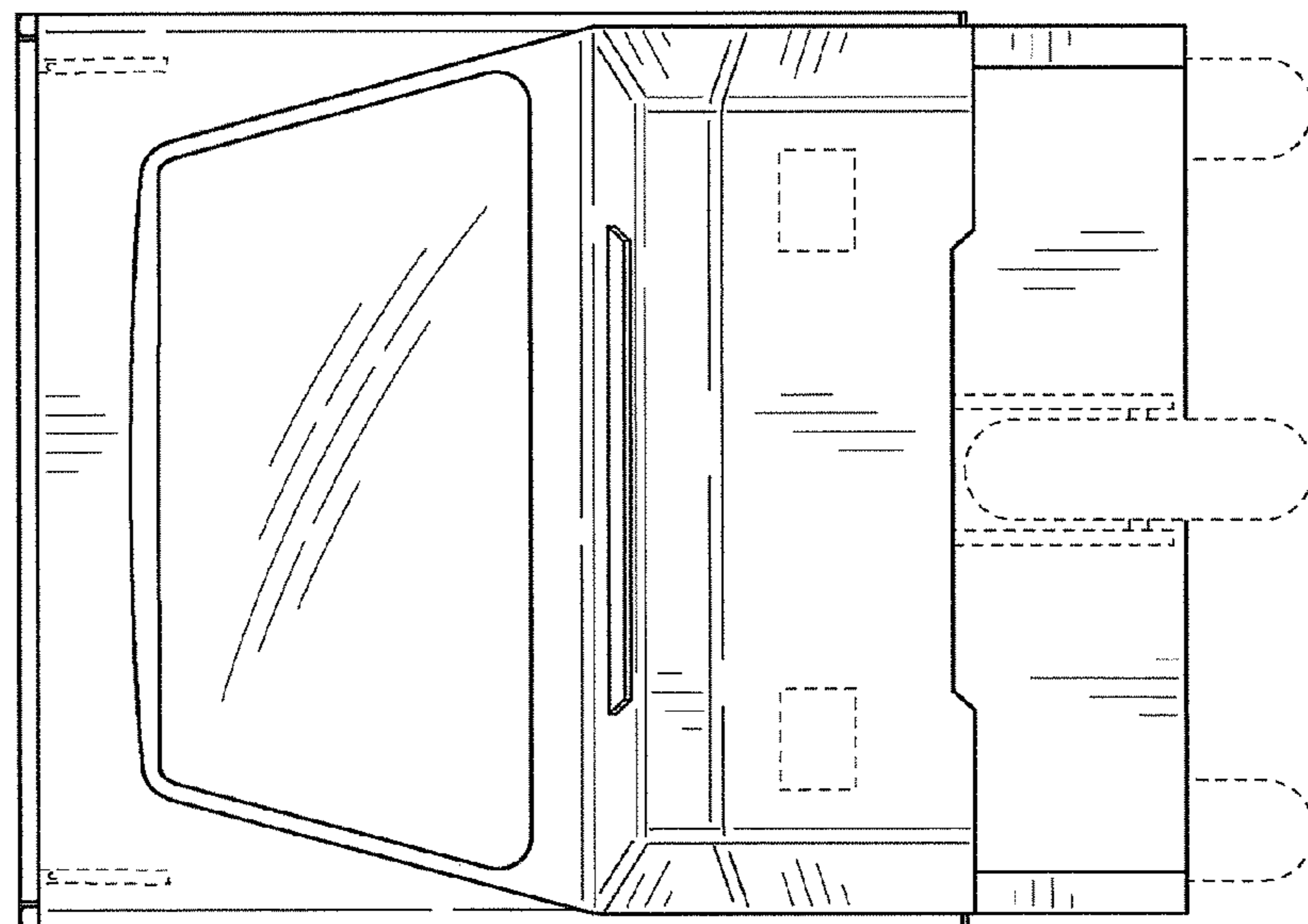

FIG. 8



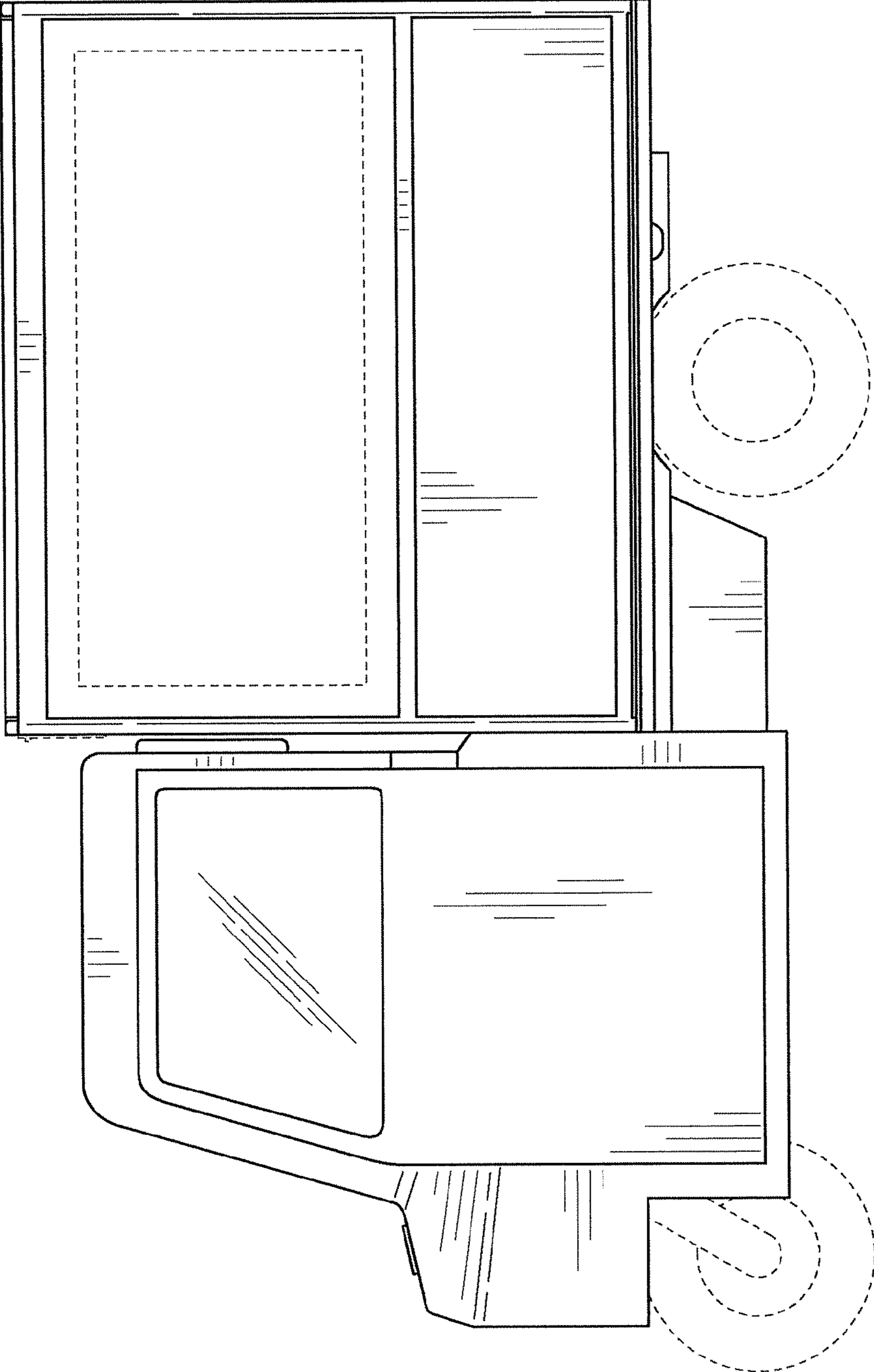

FIG. 10

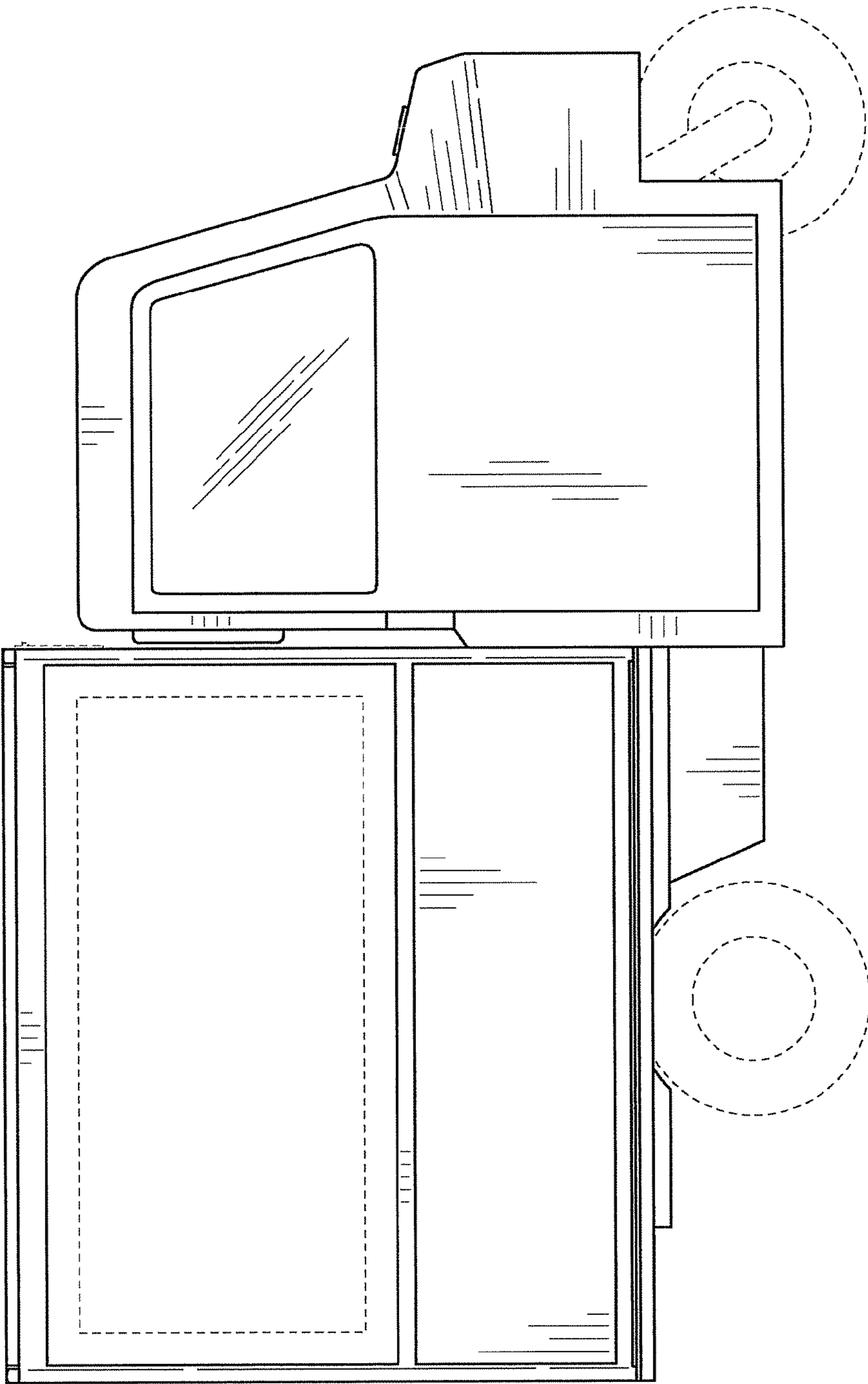

FIG. 11

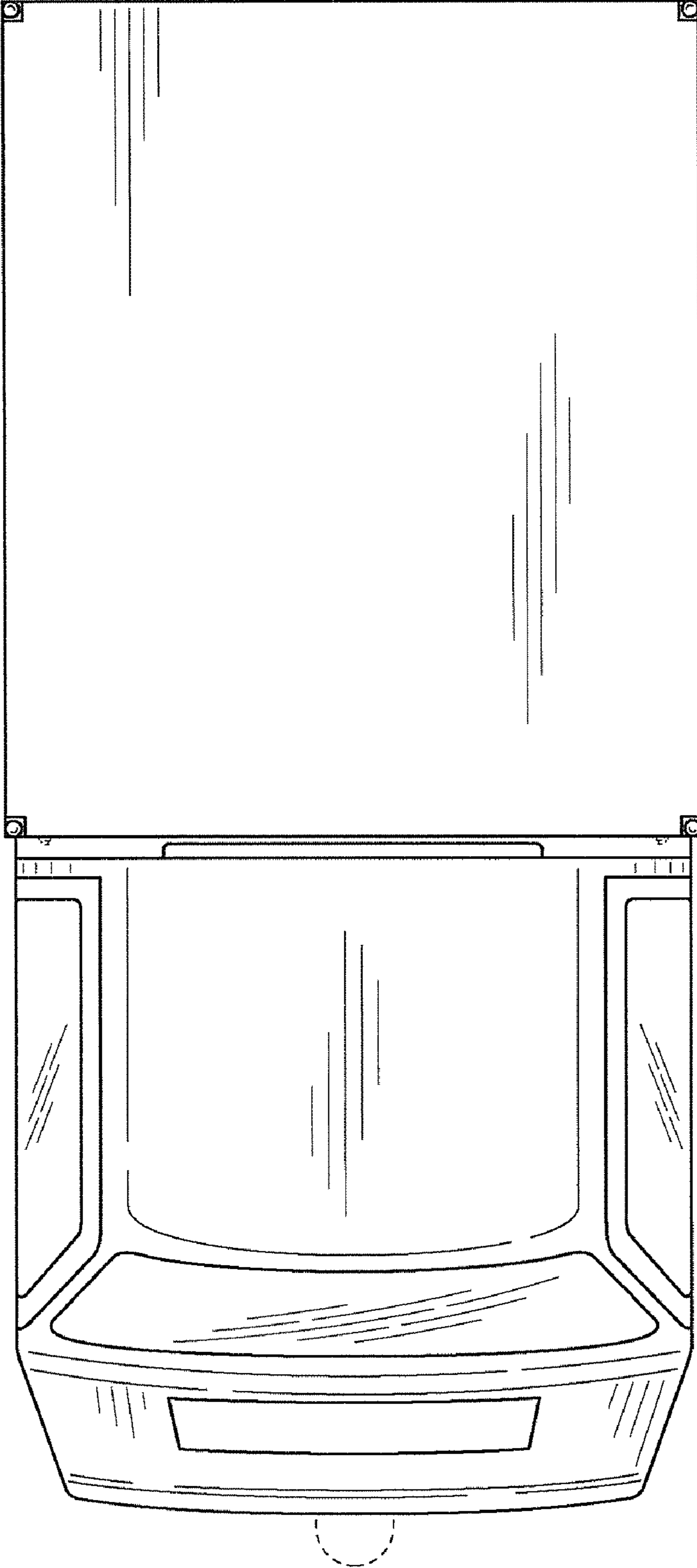

FIG. 12