



US00D653764S

(12) **United States Design Patent**
Macemon et al.

(10) **Patent No.:** **US D653,764 S**
(45) **Date of Patent:** **** Feb. 7, 2012**

(54) **THERMAL CYCLING SYSTEM FOR BIOLOGICAL ASSAYS**

(75) Inventors: **Judy Macemon**, Poway, CA (US);
David Kaplan, Carlsbad, CA (US);
Adrian Fawcett, Carlsbad, CA (US);
Kevin Simmons, San Diego, CA (US);
Andrew Zoolakis, Carlsbad, CA (US)

(73) Assignee: **Helixis, Inc.**, San Diego, CA (US)

(**) Term: **14 Years**

(21) Appl. No.: **29/358,668**

(22) Filed: **Mar. 30, 2010**

(51) **LOC (9) Cl.** **24-01**

(52) **U.S. Cl.** **D24/216**

(58) **Field of Classification Search** D24/216-232,
D24/186; D10/81; 422/500, 547, 62, 63;
435/287.1, 288.4, 303.1; 436/43, 47, 46

See application file for complete search history.

(56) **References Cited**

U.S. PATENT DOCUMENTS

D328,352	S	*	7/1992	Futatsuka	D24/232
5,169,600	A	*	12/1992	Ishizaka et al.	422/63
D457,644	S	*	5/2002	Waluszko et al.	D24/216
6,787,338	B2	*	9/2004	Wittwer et al.	435/91.2
D561,349	S	*	2/2008	Levin	D24/232
D574,280	S	*	8/2008	Wakamatsu et al.	D10/81
D591,864	S	*	5/2009	Schmidt	D24/216
D612,276	S	*	3/2010	Duffy et al.	D10/81
2008/0003649	A1		1/2008	Maltezos et al.		
2009/0269841	A1*		10/2009	Wojciechowski et al.	..	435/289.1
2009/0275014	A1		11/2009	Maltezos et al.		
2009/0275113	A1		11/2009	Maltezos et al.		

OTHER PUBLICATIONS

U.S. Appl. No. 12/753,806, filed Apr. 2, 2010 entitled "Devices and Methods for Heating Biological Samples,".

U.S. Appl. No. 12/841,725, filed Jul. 22, 2010 entitled "Optical System for Multiple Reactions,".

* cited by examiner

Primary Examiner — Anhdao Doan

(74) *Attorney, Agent, or Firm* — Tiffany B. Thomas

(57) **CLAIM**

The ornamental design for a thermal cycling system for biological assays, as shown and described.

DESCRIPTION

FIG. 1 is a perspective view of the right, front, and top sides of a thermal cycling system as described herein.

FIG. 2 is a perspective view of the left, back, and bottom sides of a thermal cycling system shown in FIG. 1.

FIG. 3 is a view of the left side of a thermal cycling system shown in FIG. 1.

FIG. 4 is a view of the right side of a thermal cycling system shown in FIG. 1.

FIG. 5 is a view of the top of a thermal cycling system shown in FIG. 1.

FIG. 6 is a view of the bottom of a thermal cycling system shown in FIG. 1.

FIG. 7 is a view of the back of a thermal cycling system shown in FIG. 1; and,

FIG. 8 is a perspective view of the front and the left side of a thermal cycling system shown in FIG. 1 wherein the lid is opened.

The broken lines in FIGS. 2 and 7 are included for the purpose of illustrating portions of the thermal cycling system for biological assays that form no part of the claimed design.

1 Claim, 8 Drawing Sheets

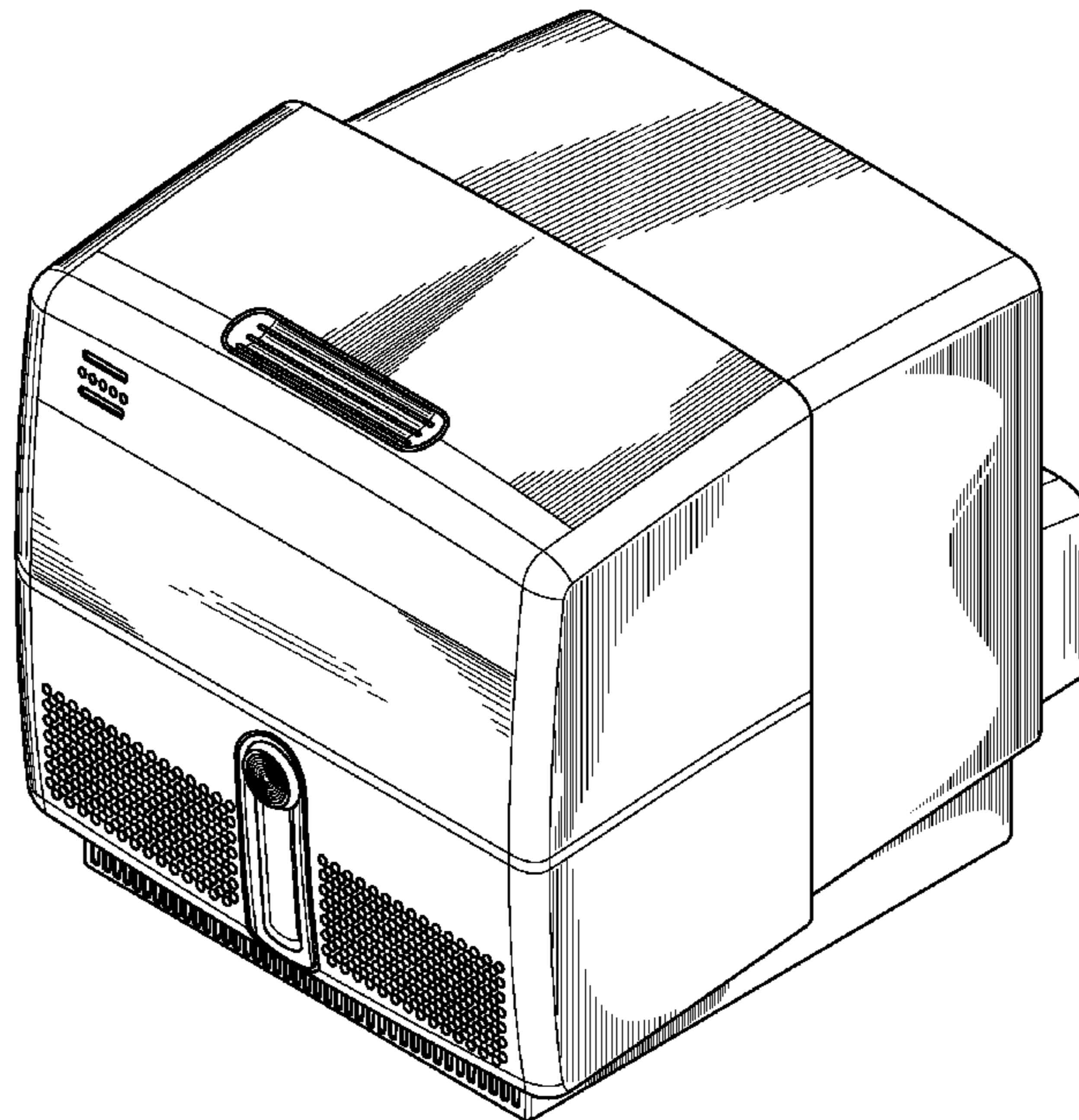

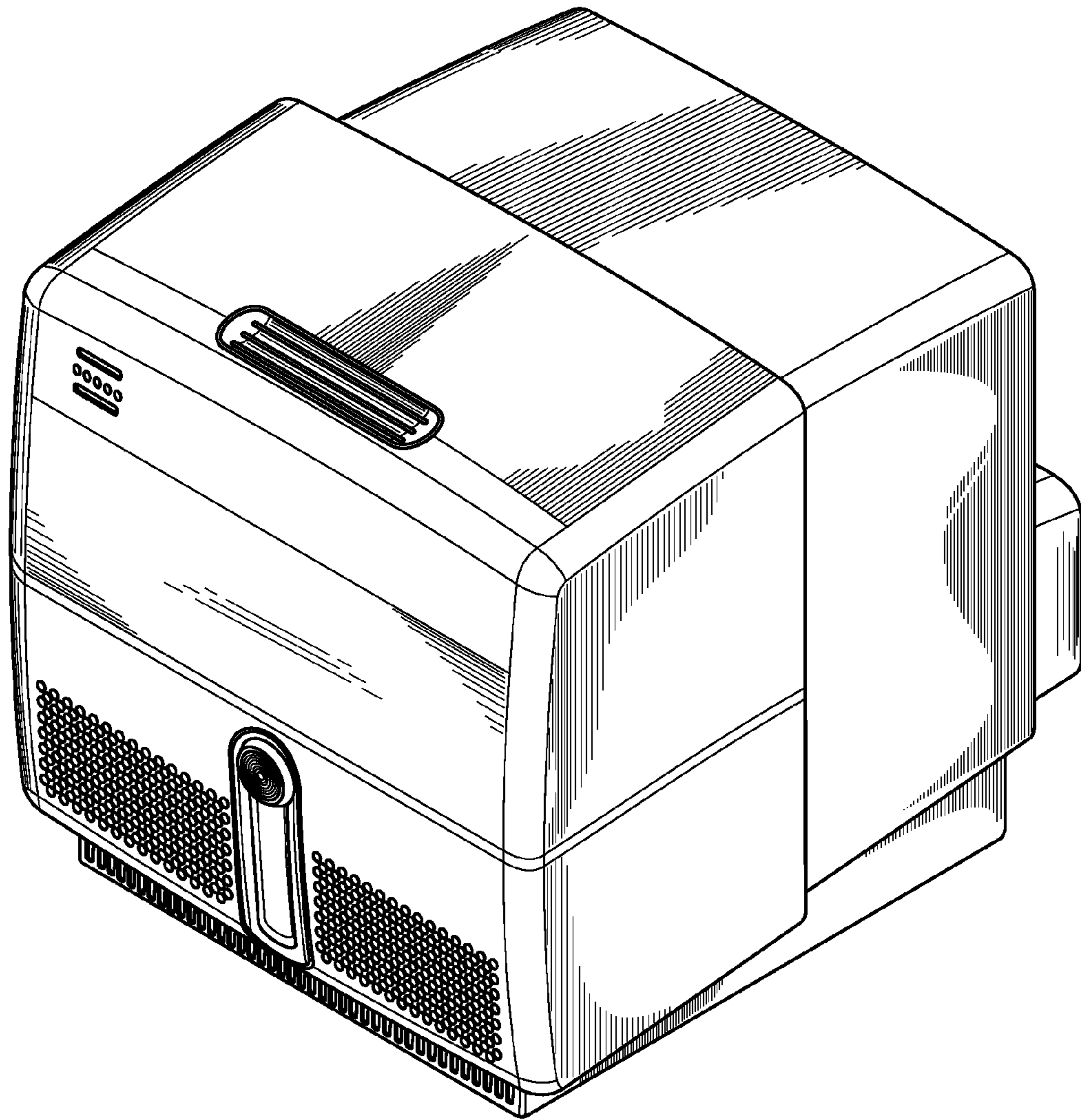

Fig. 1

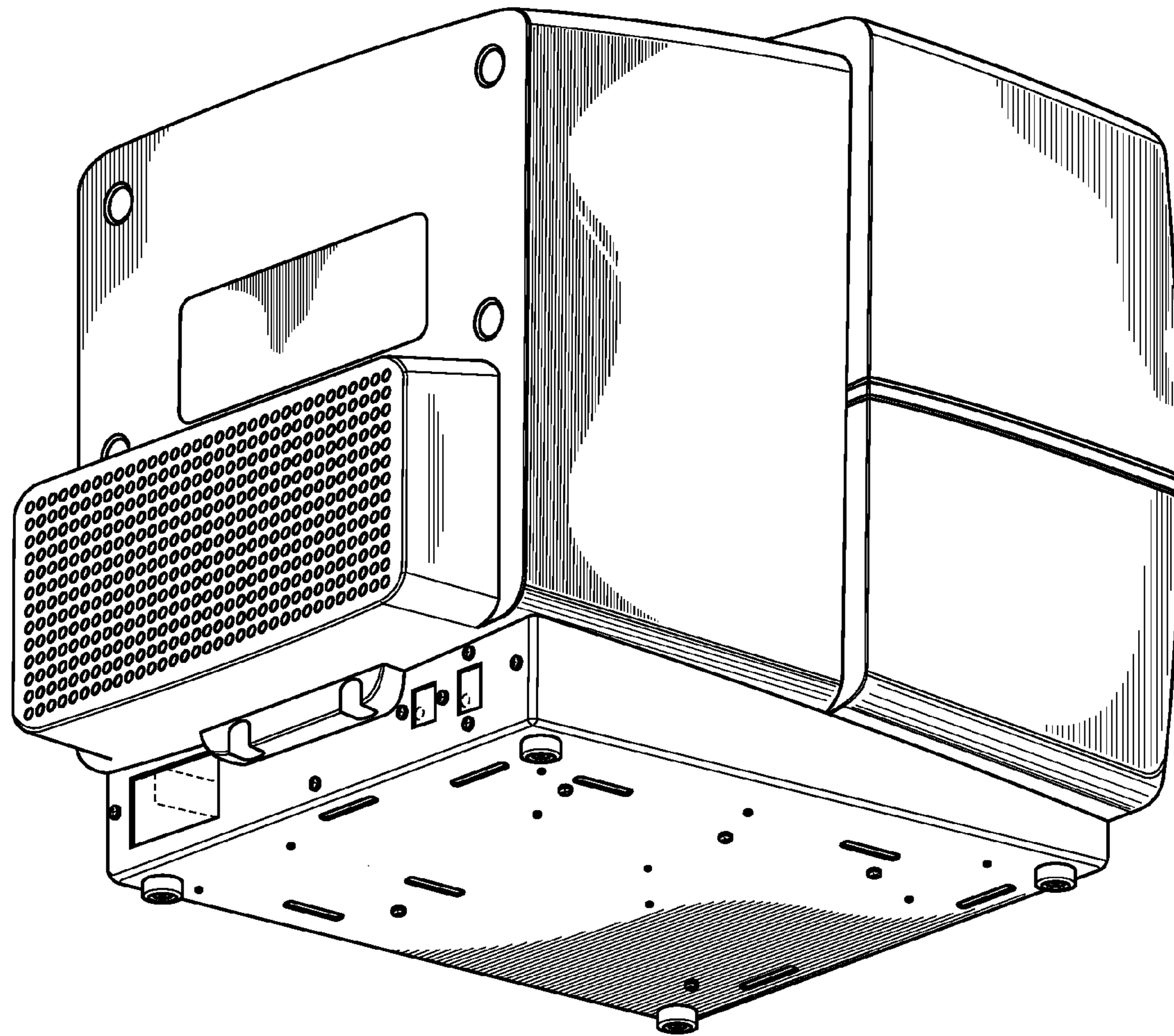

Fig. 2

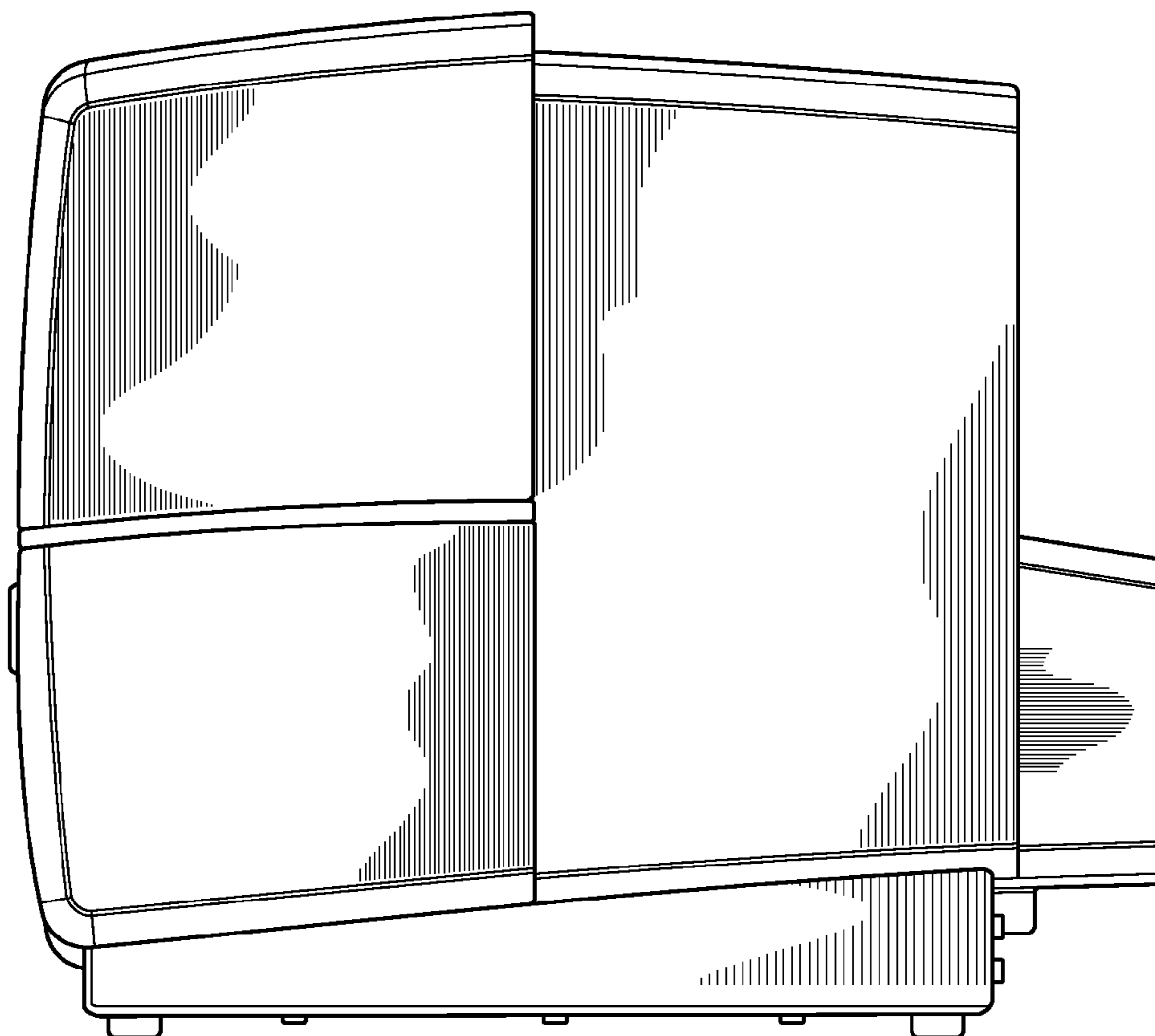

Fig. 3

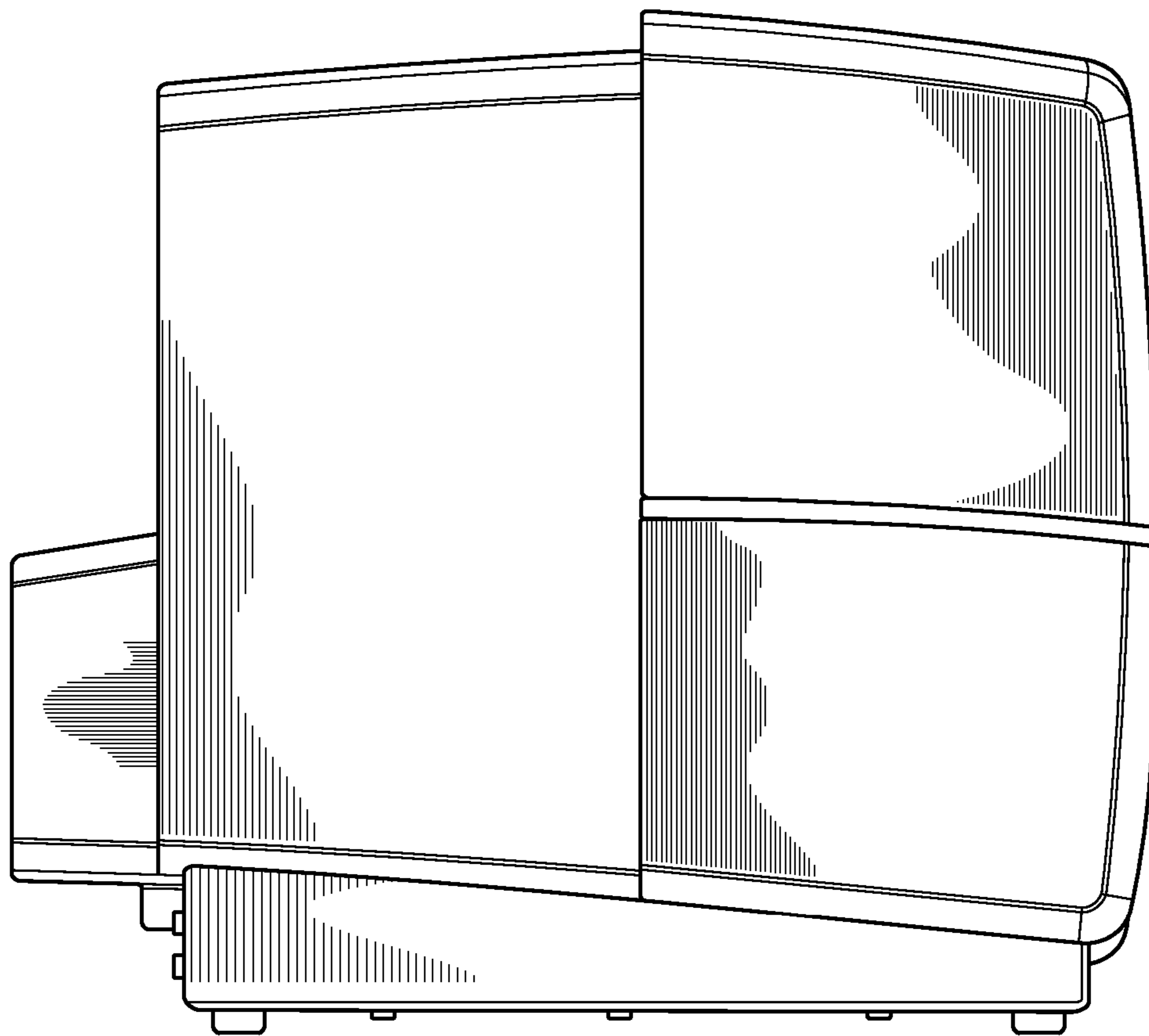

Fig. 4

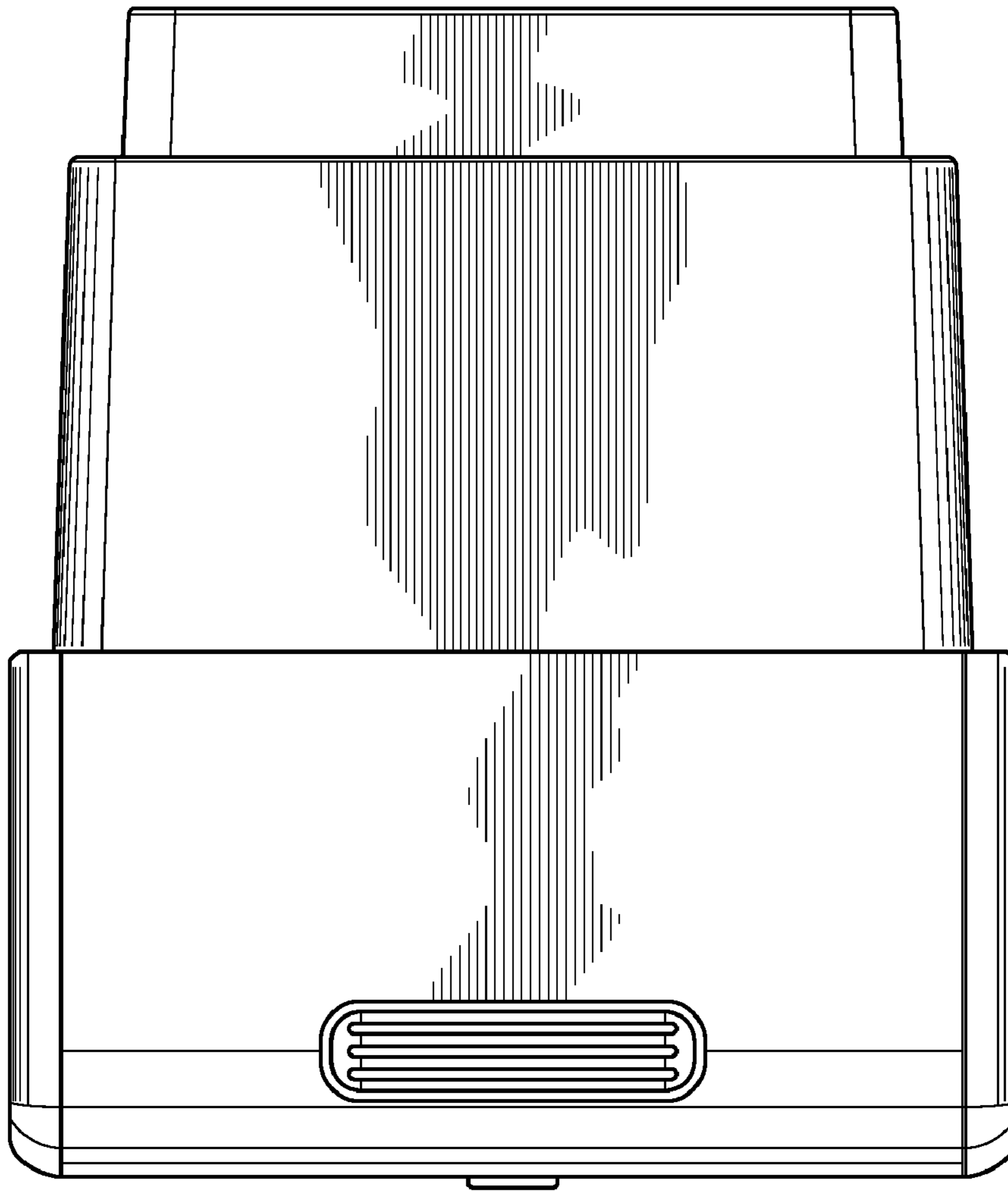

Fig. 5

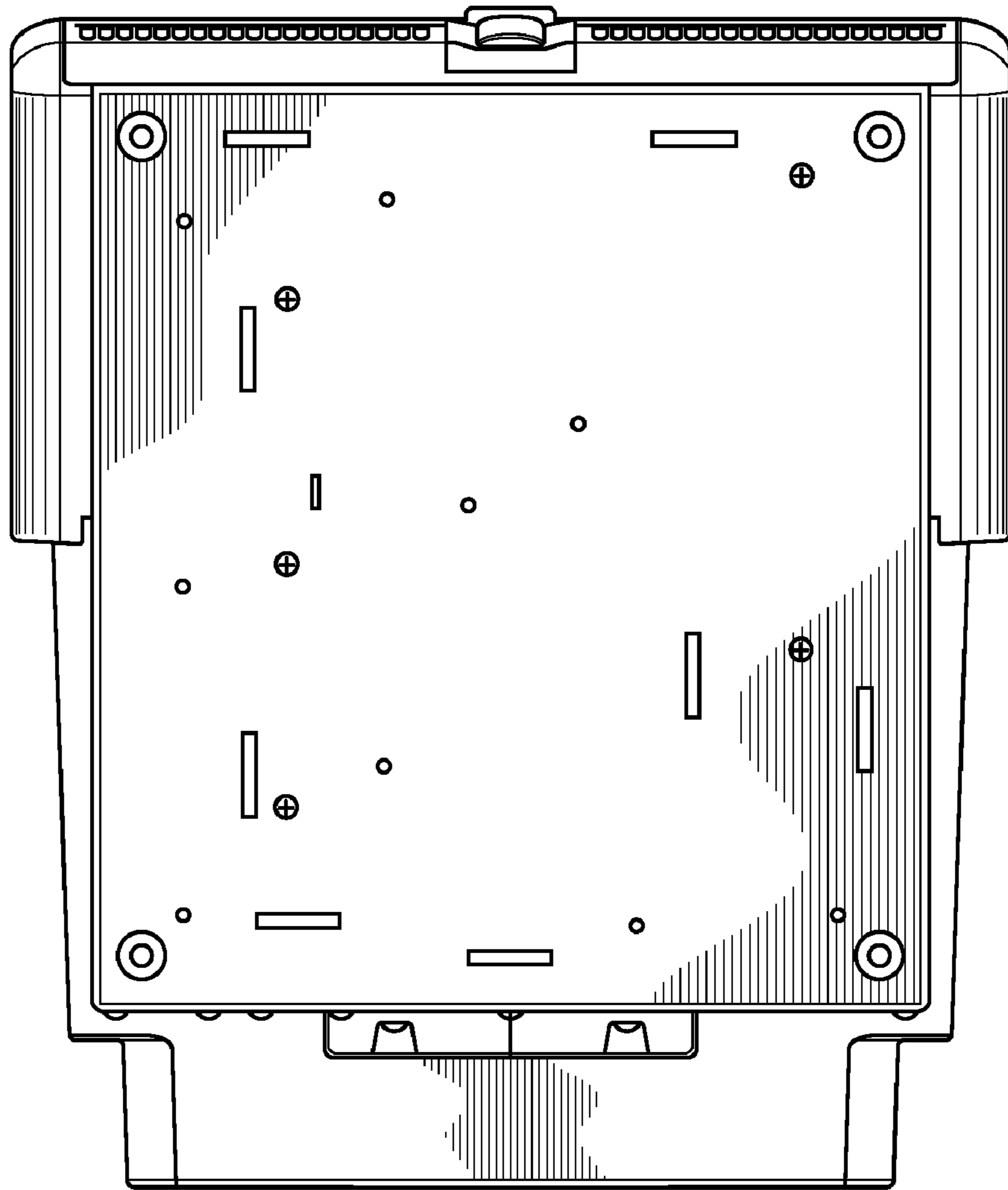

Fig. 6

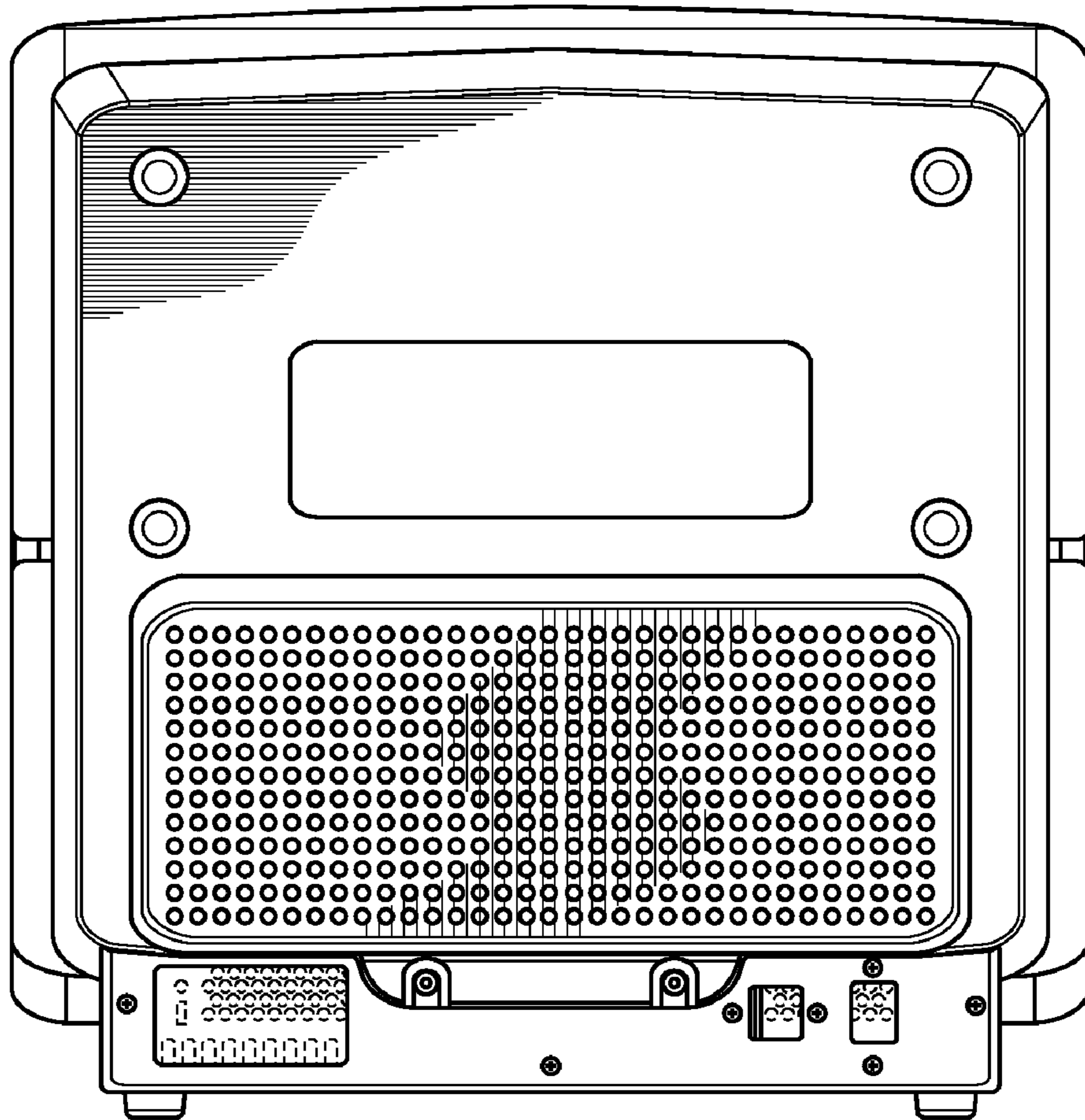

Fig. 7

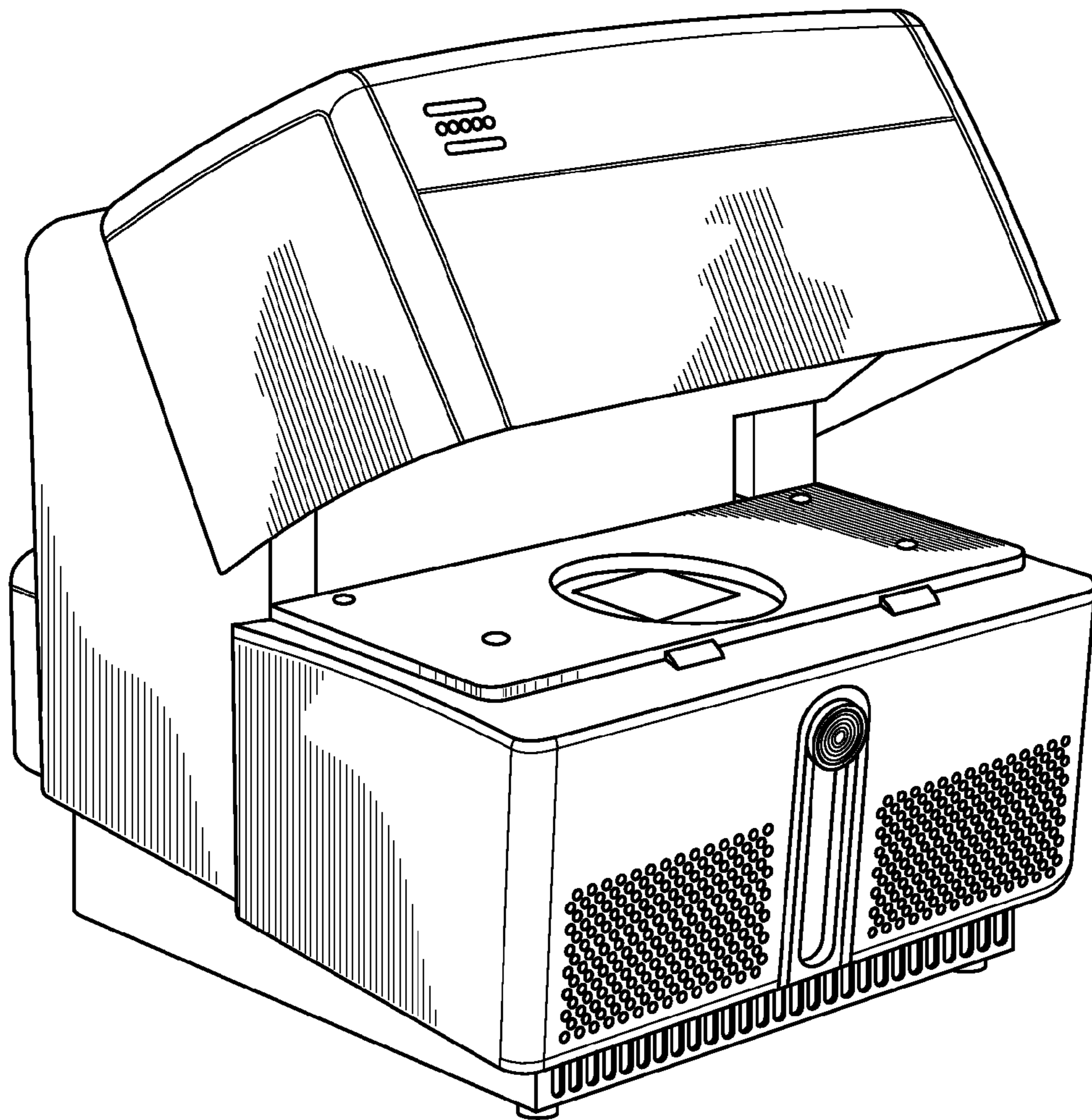

Fig. 8