



US00D653294S

(12) **United States Design Patent**  
**Loveland et al.**

(10) **Patent No.:** **US D653,294 S**  
(45) **Date of Patent:** **\*\* Jan. 31, 2012**

(54) **FOOT PROPELLED VEHICLE**

(75) Inventors: **Andrew John Loveland**, Henley on Thames (GB); **Robert Paul Upton**, Totnes (GB)

(73) Assignee: **Early Rider Limited** (GB)

(\*\*) Term: **14 Years**

(21) Appl. No.: **29/390,204**

(22) Filed: **Apr. 21, 2011**

(51) **LOC (9) Cl.** ..... **21-01**

(52) **U.S. Cl.** ..... **D21/419; D21/427**

(58) **Field of Classification Search** ..... D21/412, D21/414, 415, 419, 424, 426, 427, 428, 503, D21/592, 650, 831; 280/1.16, 1.165, 1.167, 280/1.191, 1.192, 1.22, 1.23, 827, 828, 87.01, 280/87.021, 87.03

See application file for complete search history.

(56) **References Cited**

**U.S. PATENT DOCUMENTS**

D228,400 S *	9/1973	Novak	.....	D21/428
D232,454 S *	8/1974	Wormser	.....	D21/832
D248,683 S *	7/1978	Nakao et al.	.....	D21/428
D257,375 S *	10/1980	Nottingham et al.	.....	D21/428
D257,683 S *	12/1980	Appel et al.	.....	D21/427
D283,905 S *	5/1986	Kane et al.	.....	D21/428
D352,074 S *	11/1994	Bunn, Jr.	.....	D21/428
D388,839 S *	1/1998	Hsieh	.....	D21/419
D389,533 S *	1/1998	Maxwell	.....	D21/428
D444,825 S *	7/2001	Child et al.	.....	D21/428
D449,081 S *	10/2001	Chang	.....	D21/424
D587,322 S *	2/2009	Child et al.	.....	D21/427
D606,596 S *	12/2009	Kruger	.....	D21/427

**FOREIGN PATENT DOCUMENTS**

WO W02010/116126 10/2010

\* cited by examiner

*Primary Examiner* — Cynthia M Chin

(74) *Attorney, Agent, or Firm* — McDonnell Boehnen Hulbert & Berghoff

(57) **CLAIM**

The ornamental design for a foot propelled vehicle, as shown and described.

**DESCRIPTION**

FIG. 1 is a perspective view from the front and one side of a foot propelled vehicle of a first embodiment of the invention; FIG. 2 is a perspective view from the front and the other side of the embodiment of FIG. 1; FIG. 3 is a view from one side of the embodiment of FIG. 1; FIG. 4 is a view from the other side of the embodiment of FIG. 1; FIG. 5 is a front view of the embodiment of FIG. 1; FIG. 6 is a rear view of the embodiment of FIG. 1; FIG. 7 is a top view of the embodiment of FIG. 1; FIG. 8 is a perspective view from the front and one side of a foot propelled vehicle of a second embodiment of the invention; FIG. 9 is a perspective view from the front and the other side of the embodiment of FIG. 8; FIG. 10 is a view from one side of the embodiment of FIG. 8; FIG. 11 is a view from the other side of the embodiment of FIG. 8; FIG. 12 is a front view of the embodiment of FIG. 8; FIG. 13 is a rear view of the embodiment of FIG. 8; FIG. 14 is a top view of the embodiment of FIG. 8; and, FIG. 15 is a perspective view from the rear and the other side of the embodiment of FIG. 8.

**1 Claim, 8 Drawing Sheets**

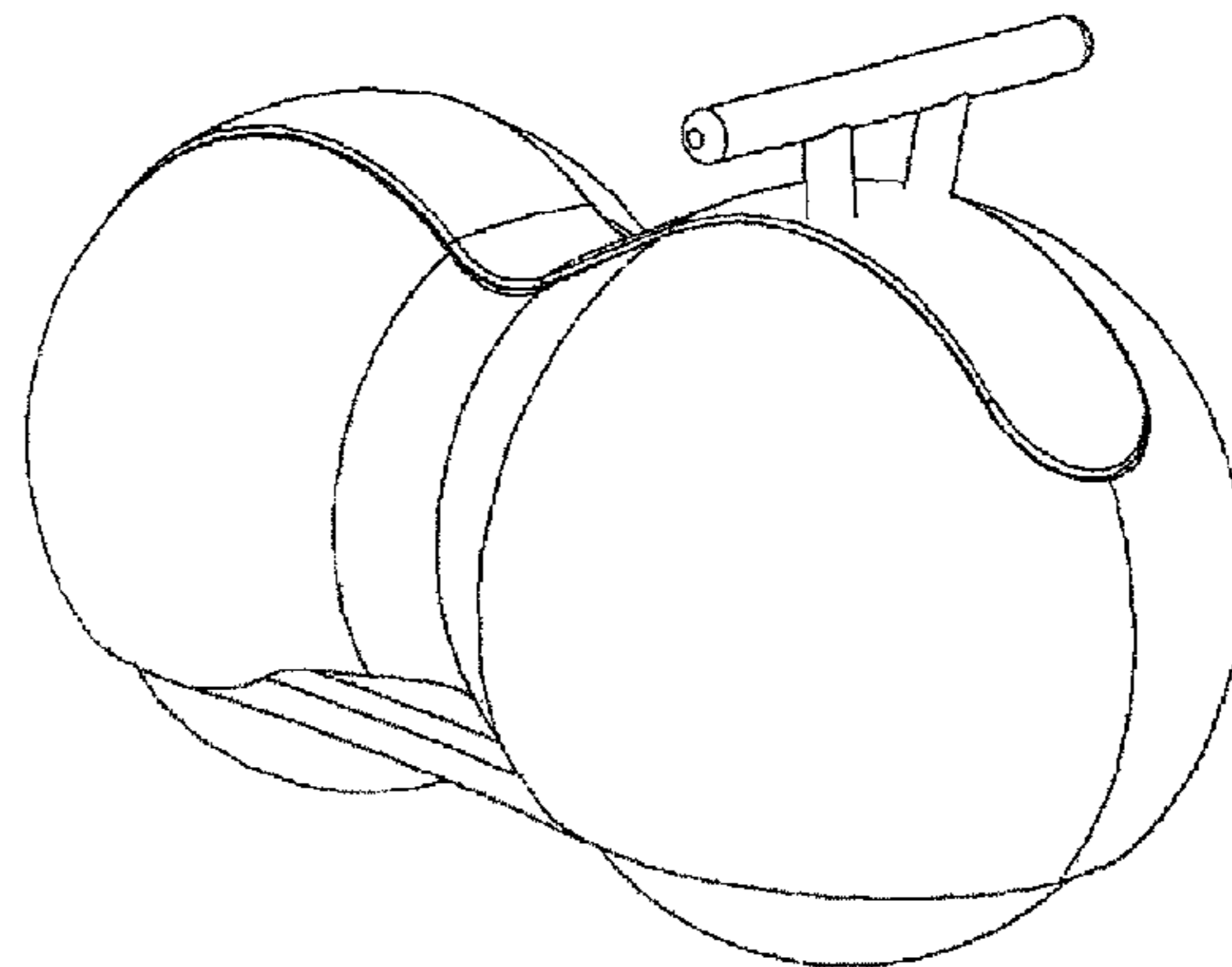
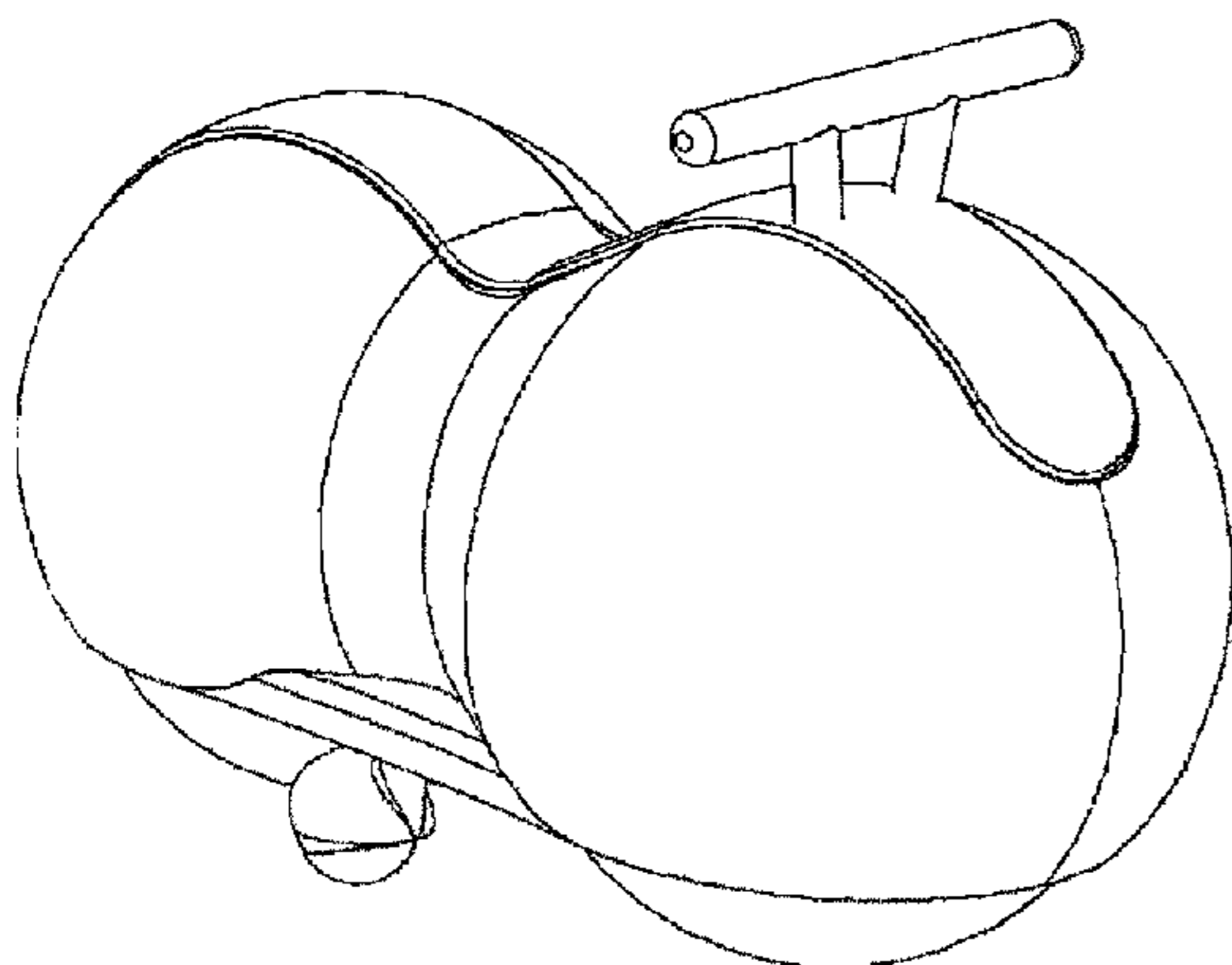

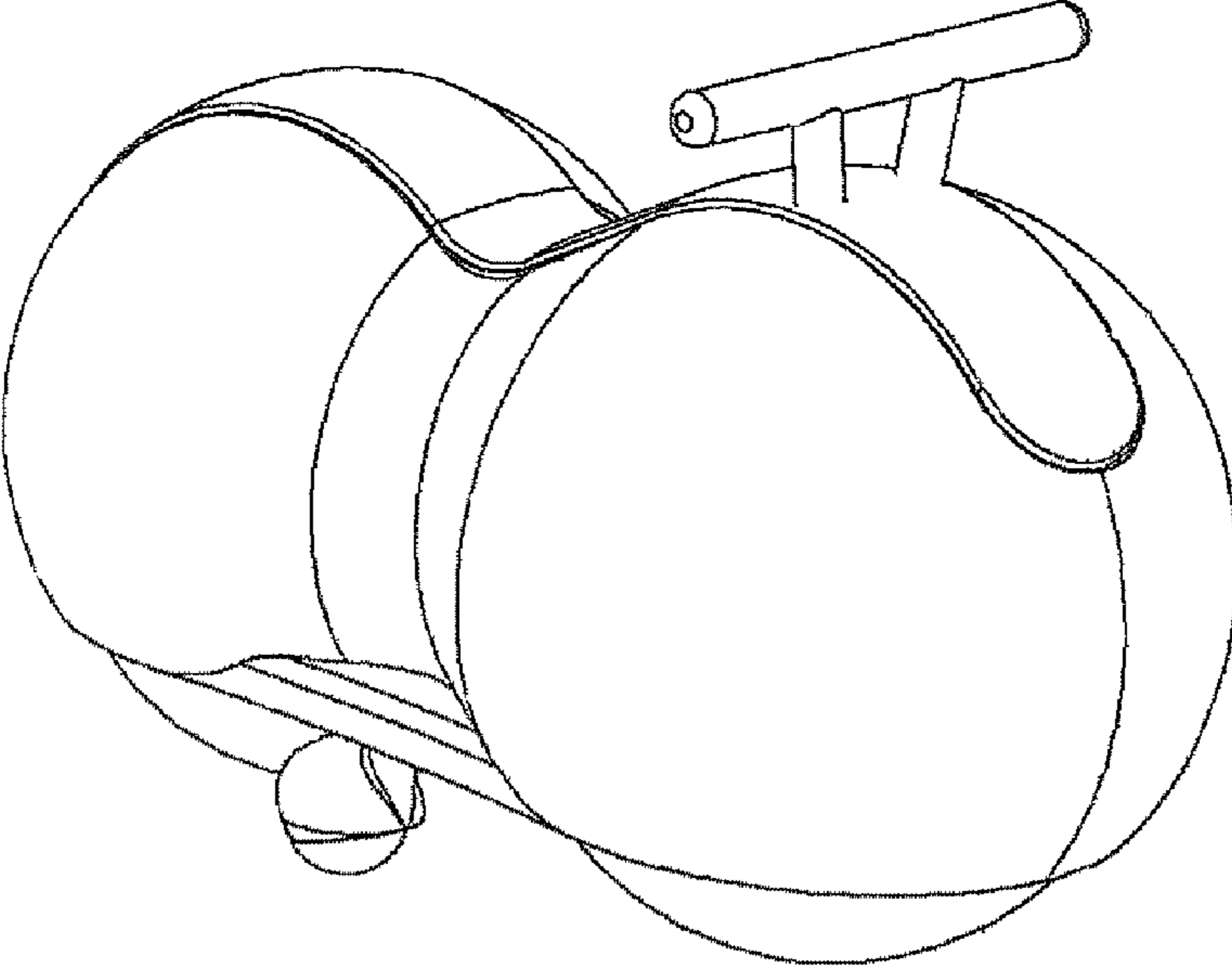

Figure 1

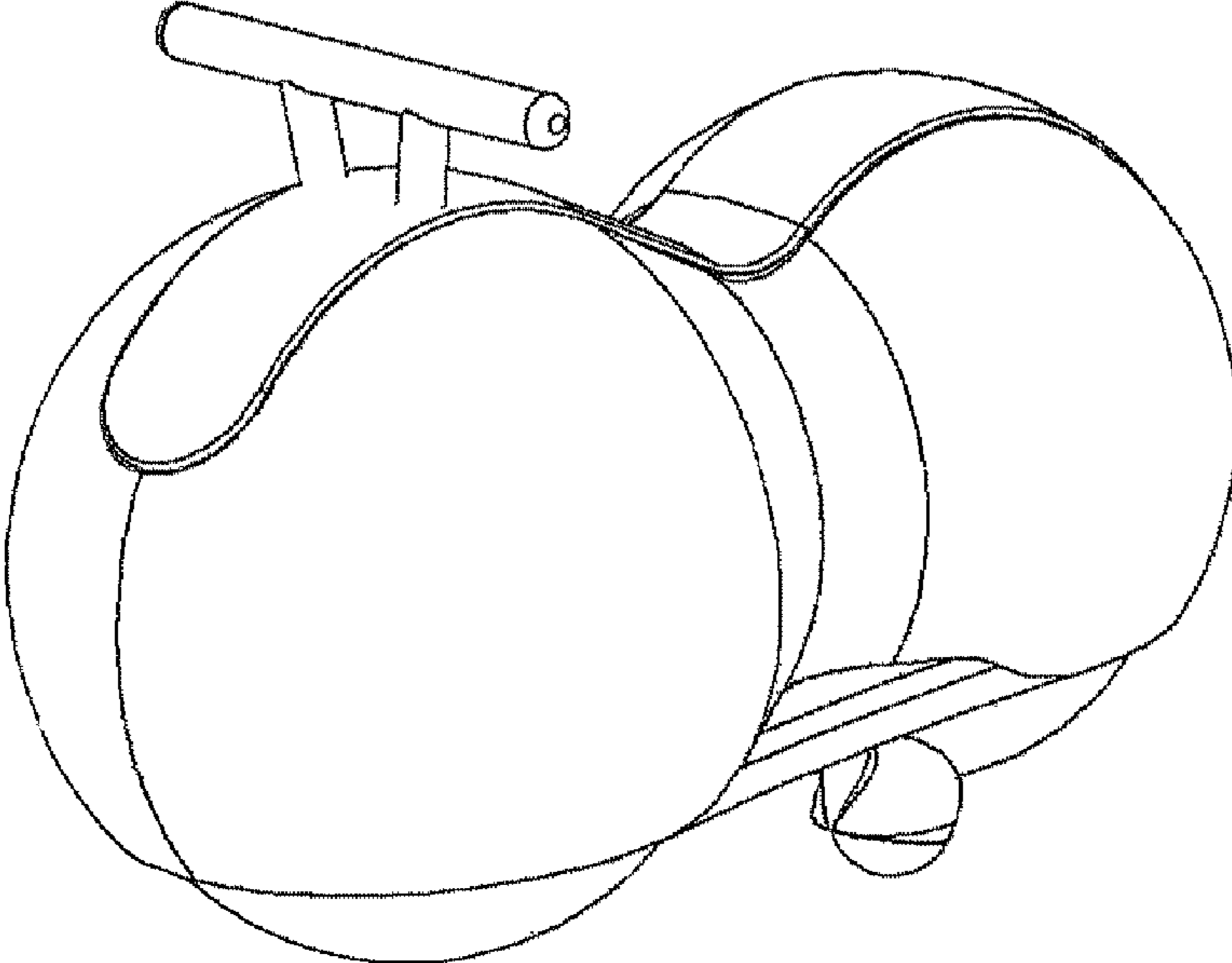

Figure 2

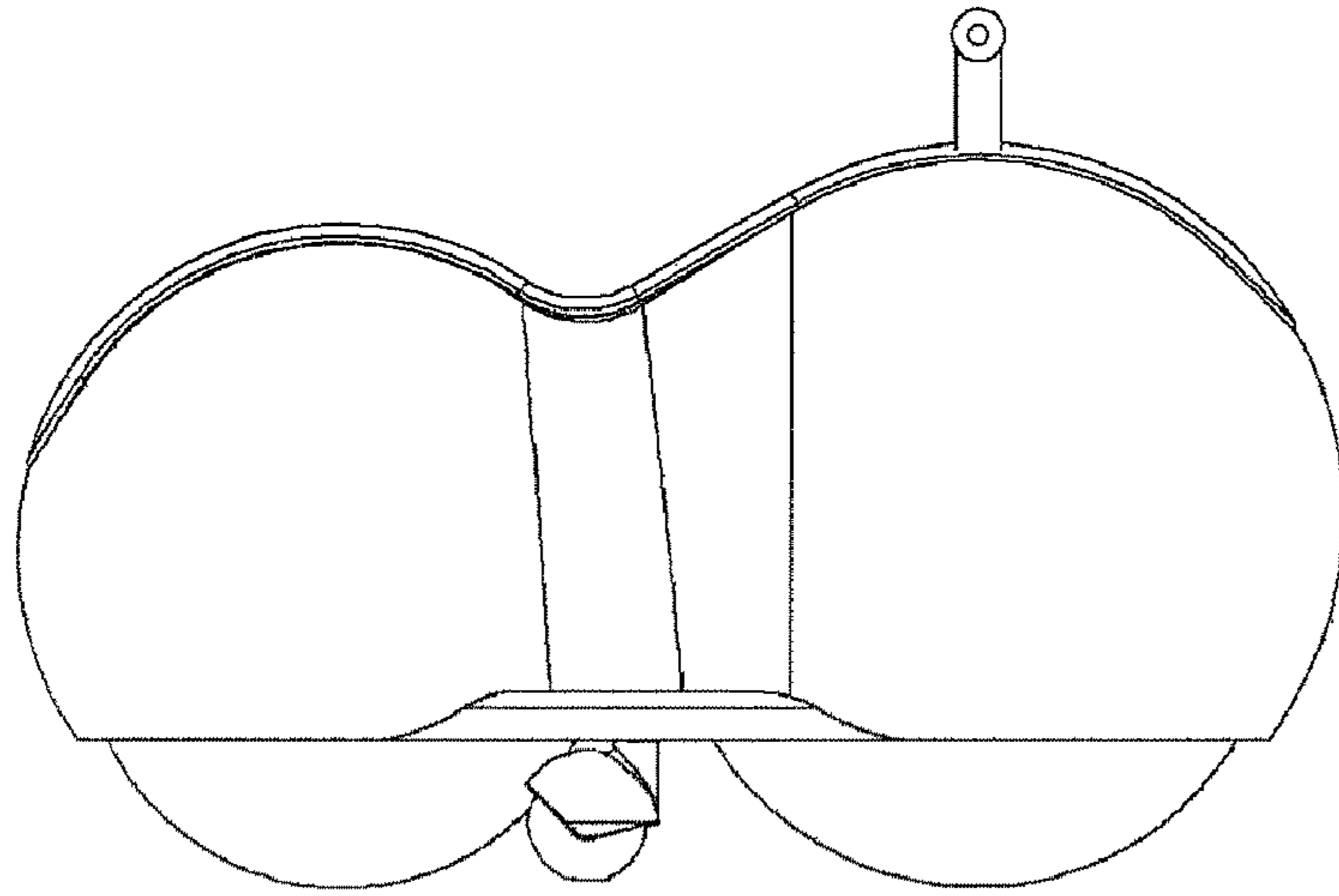

Figure 3

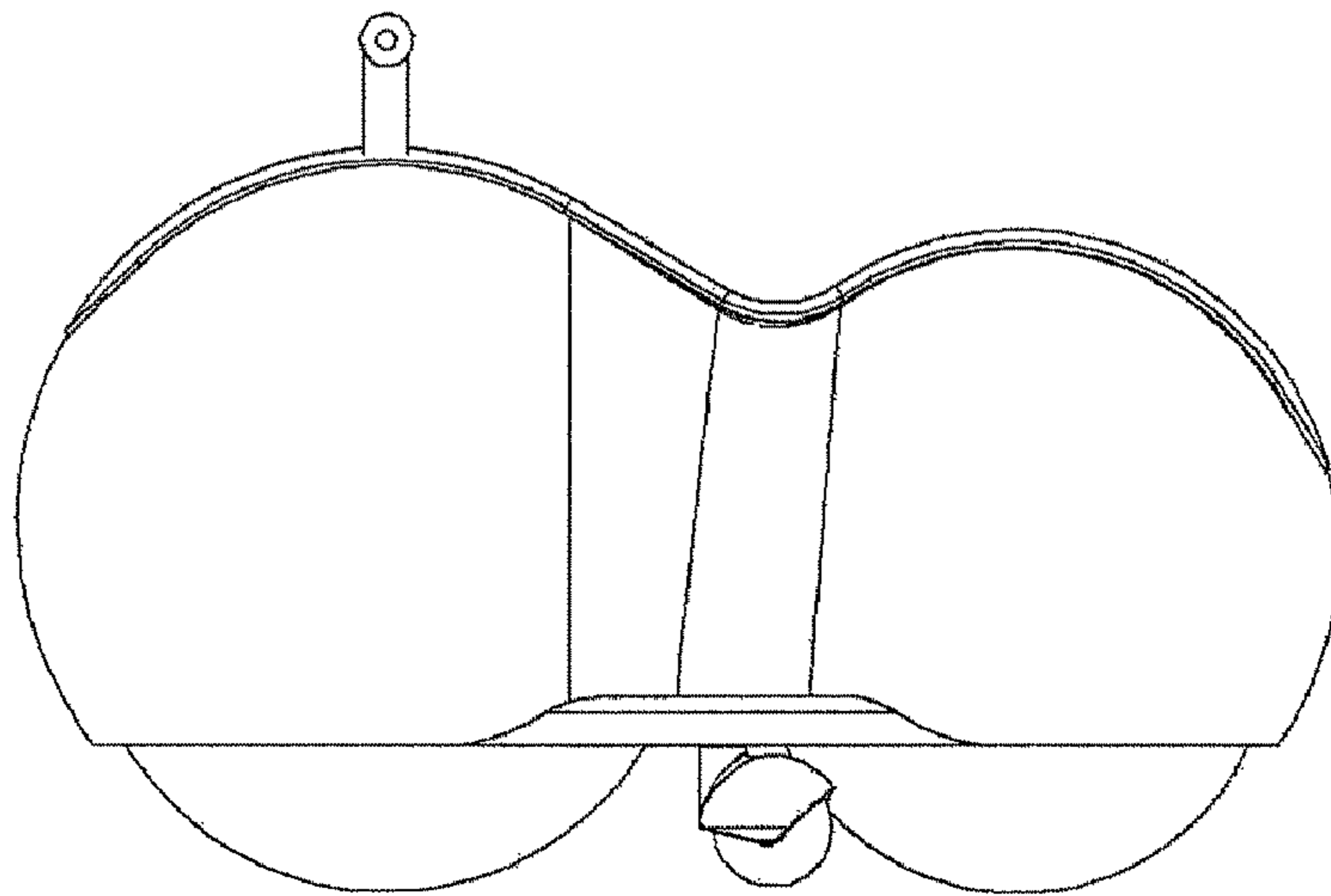

Figure 4

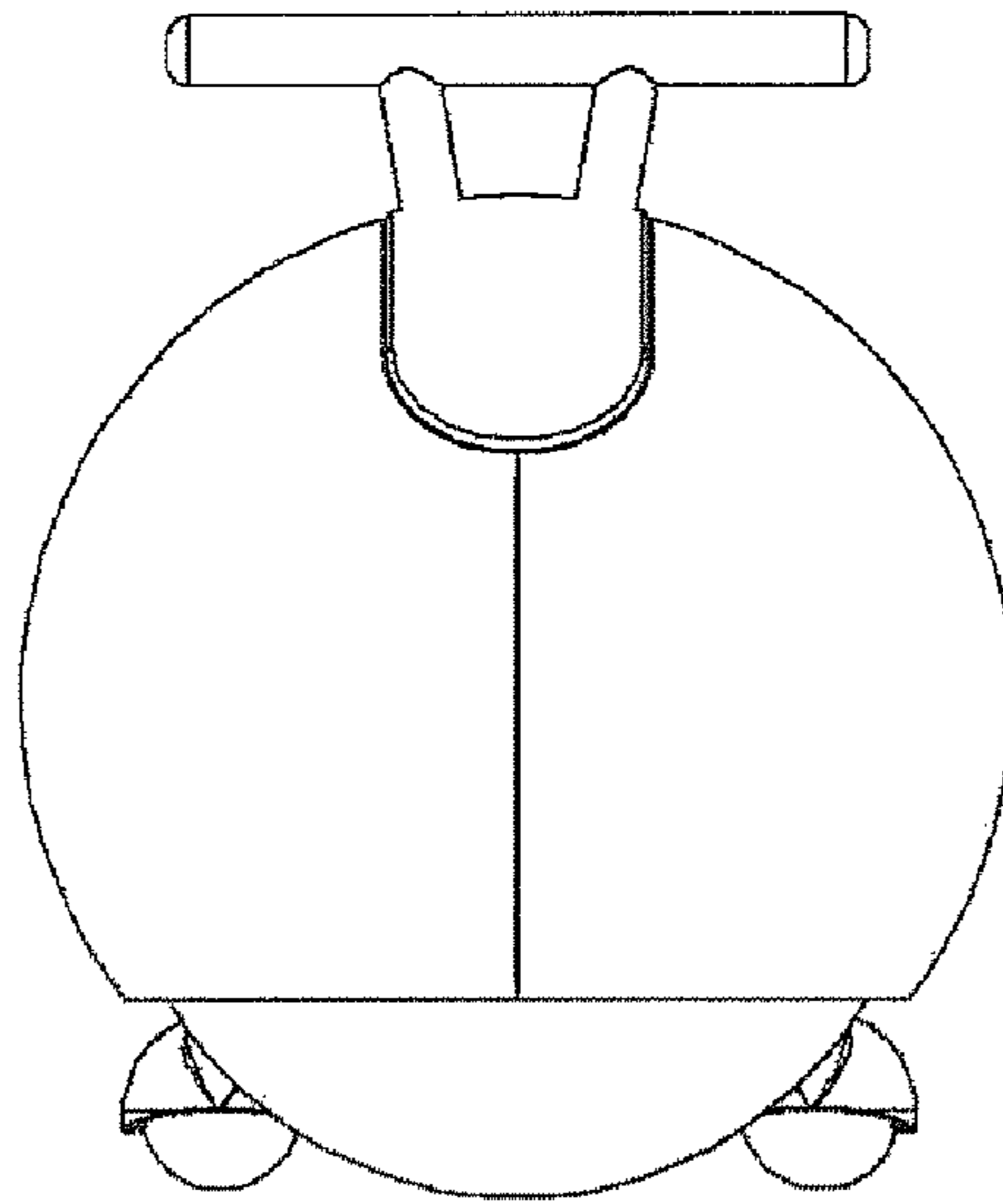

Figure 5

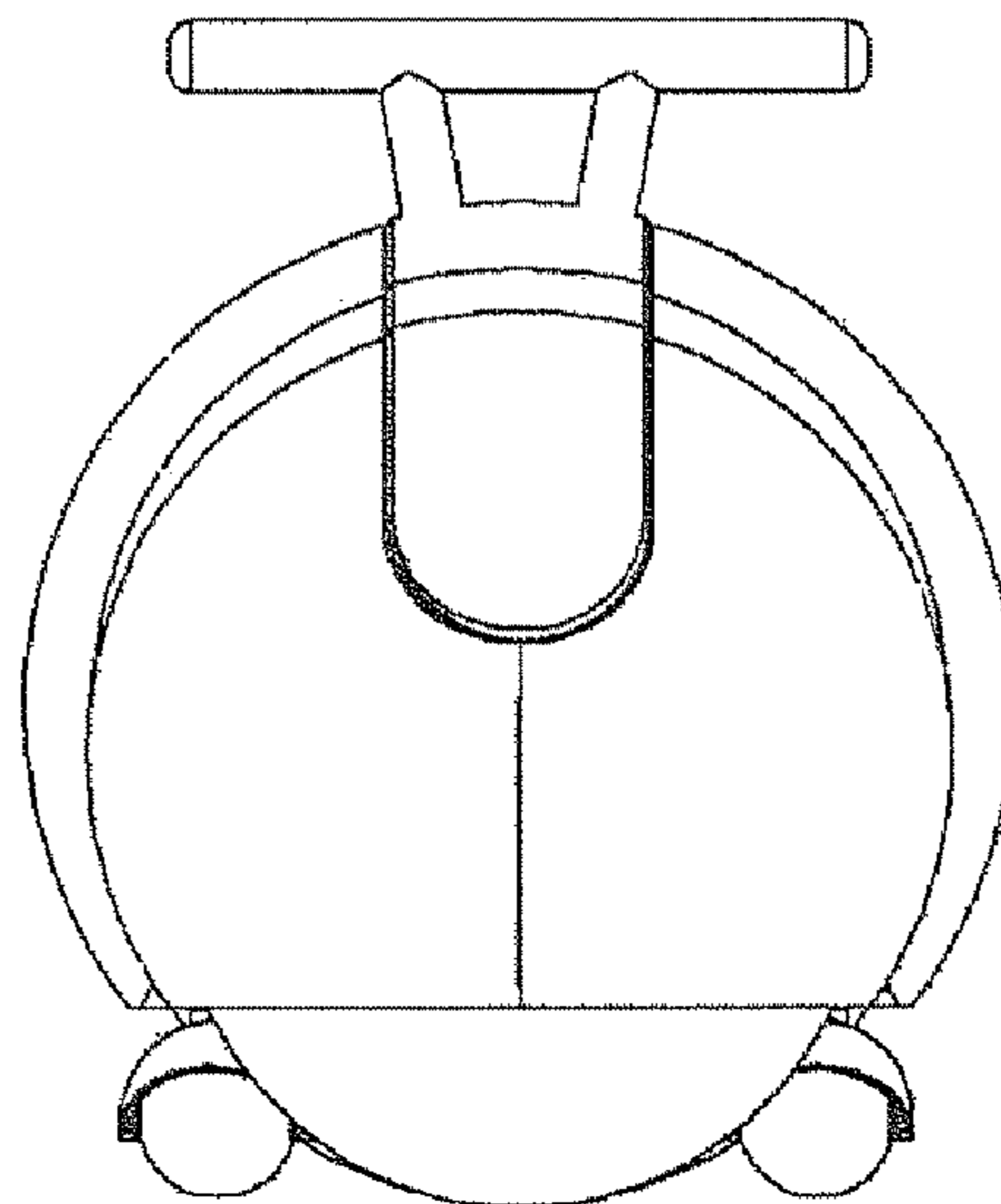

Figure 6

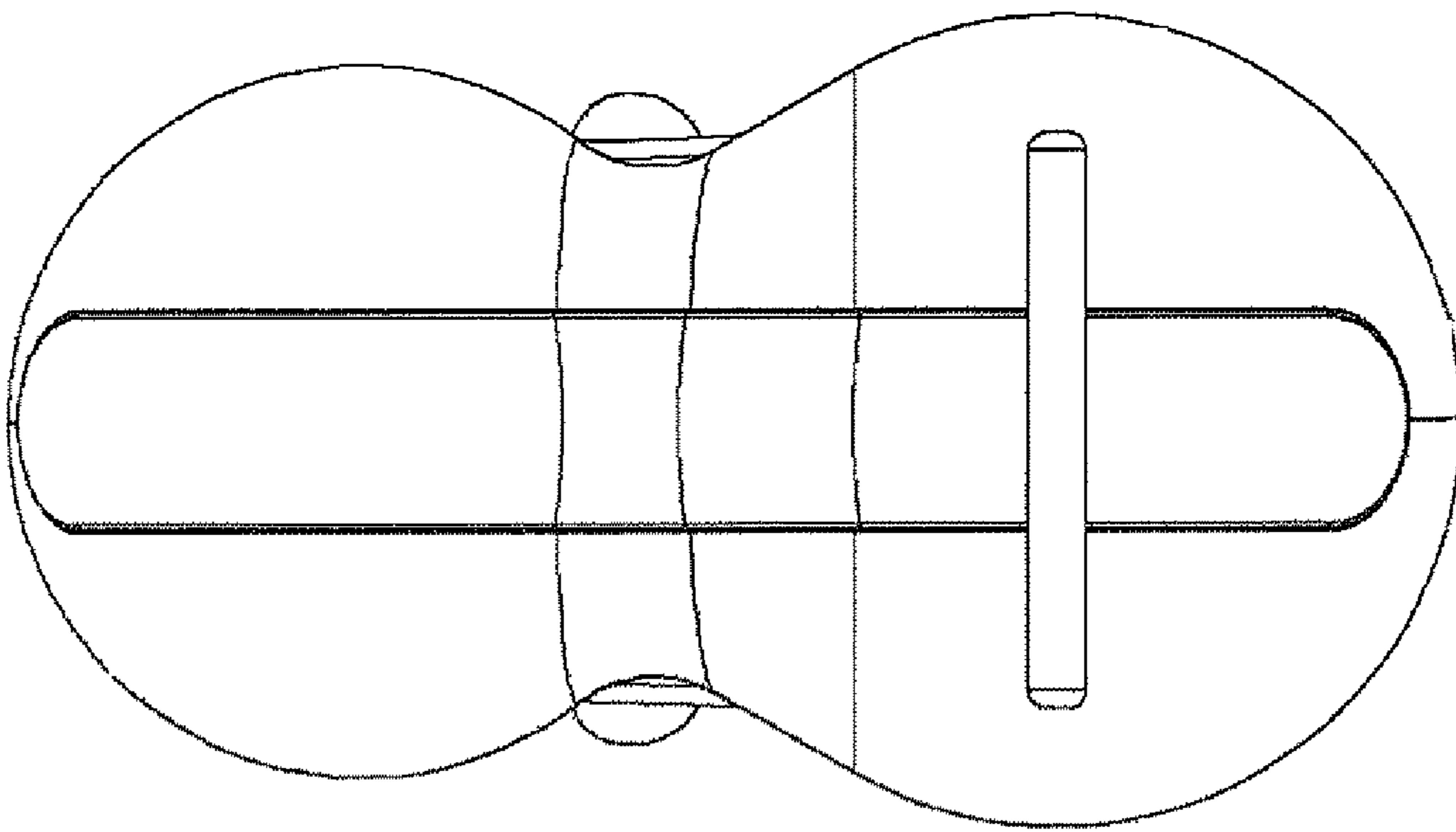

Figure 7

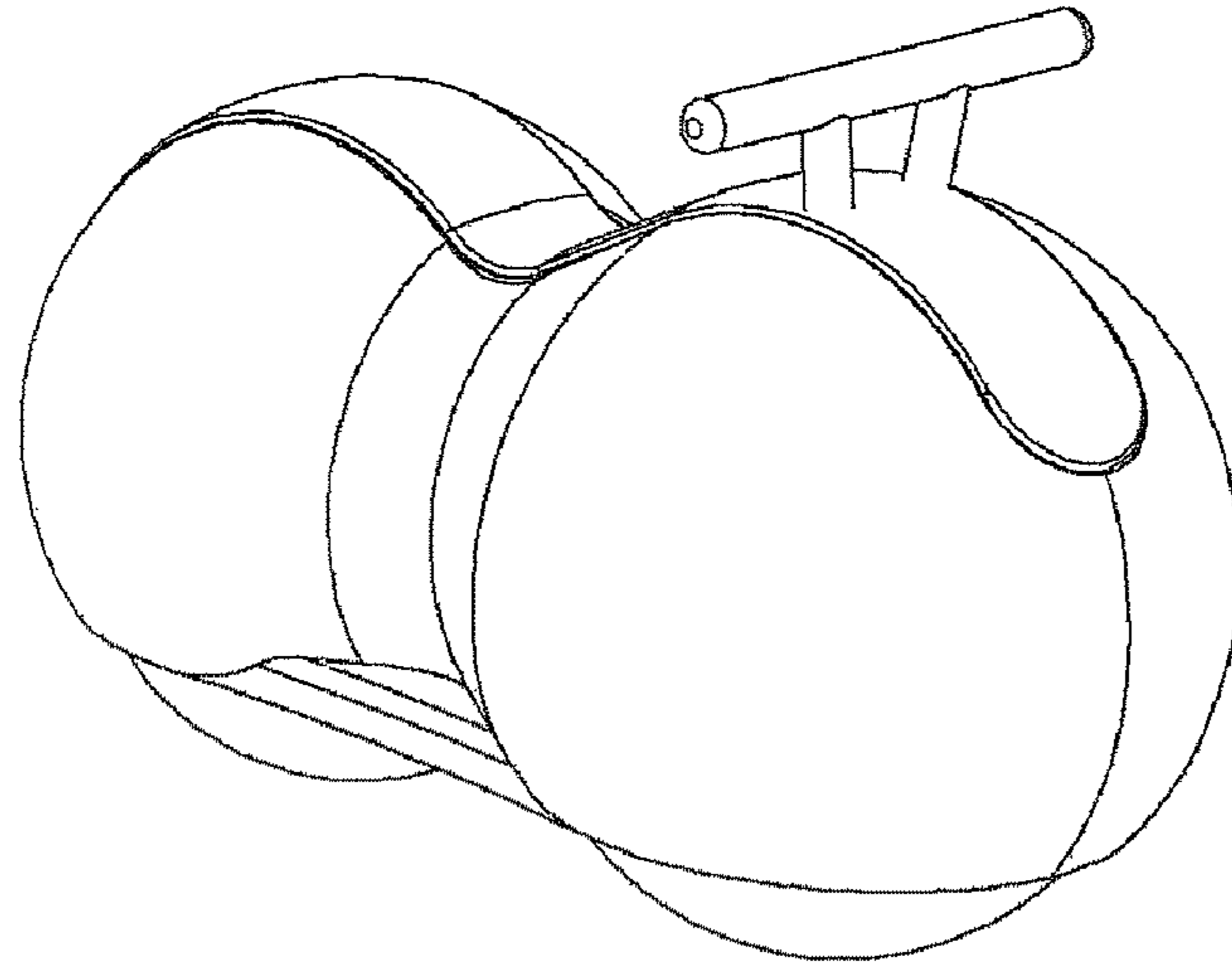

Figure 8

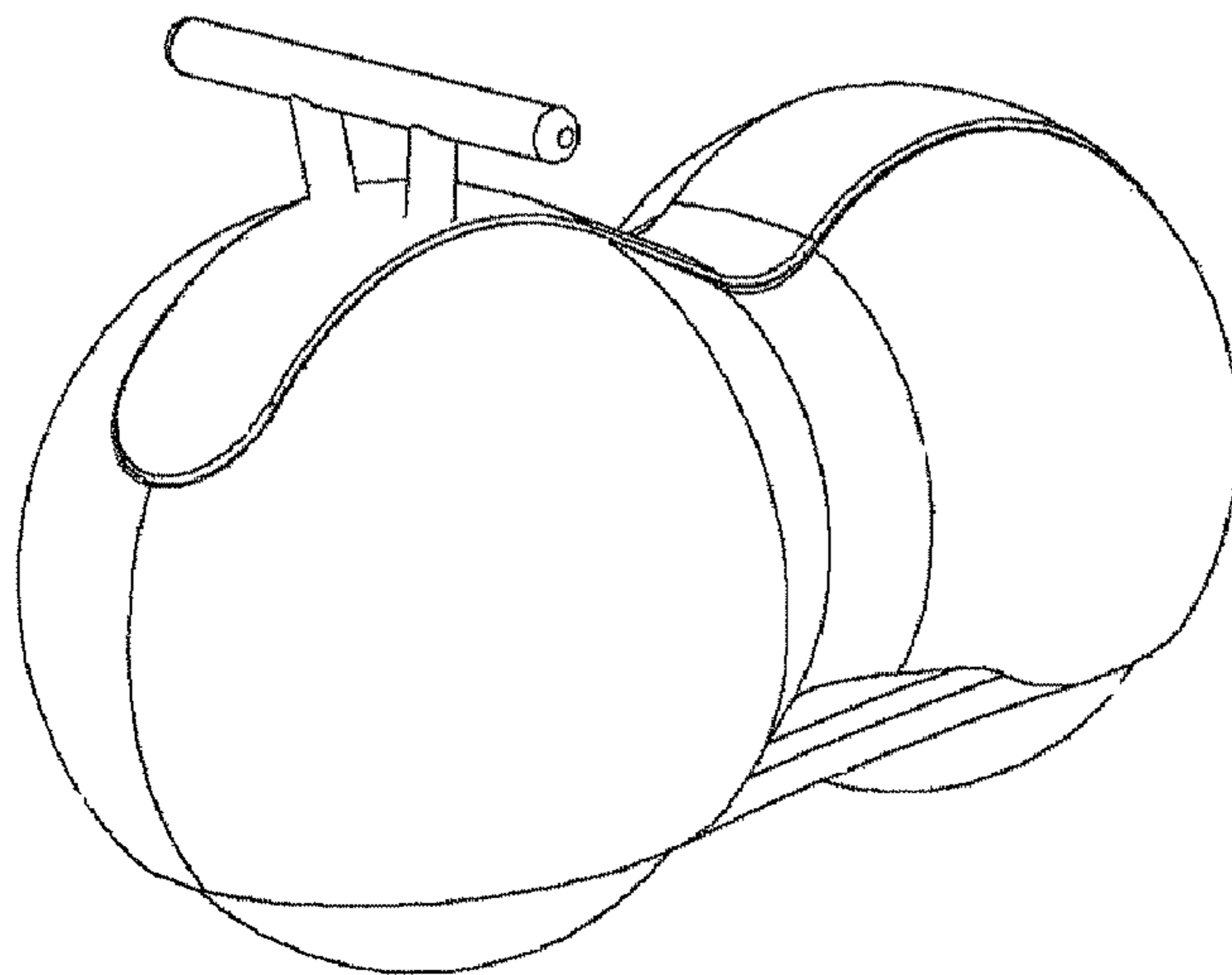

Figure 9

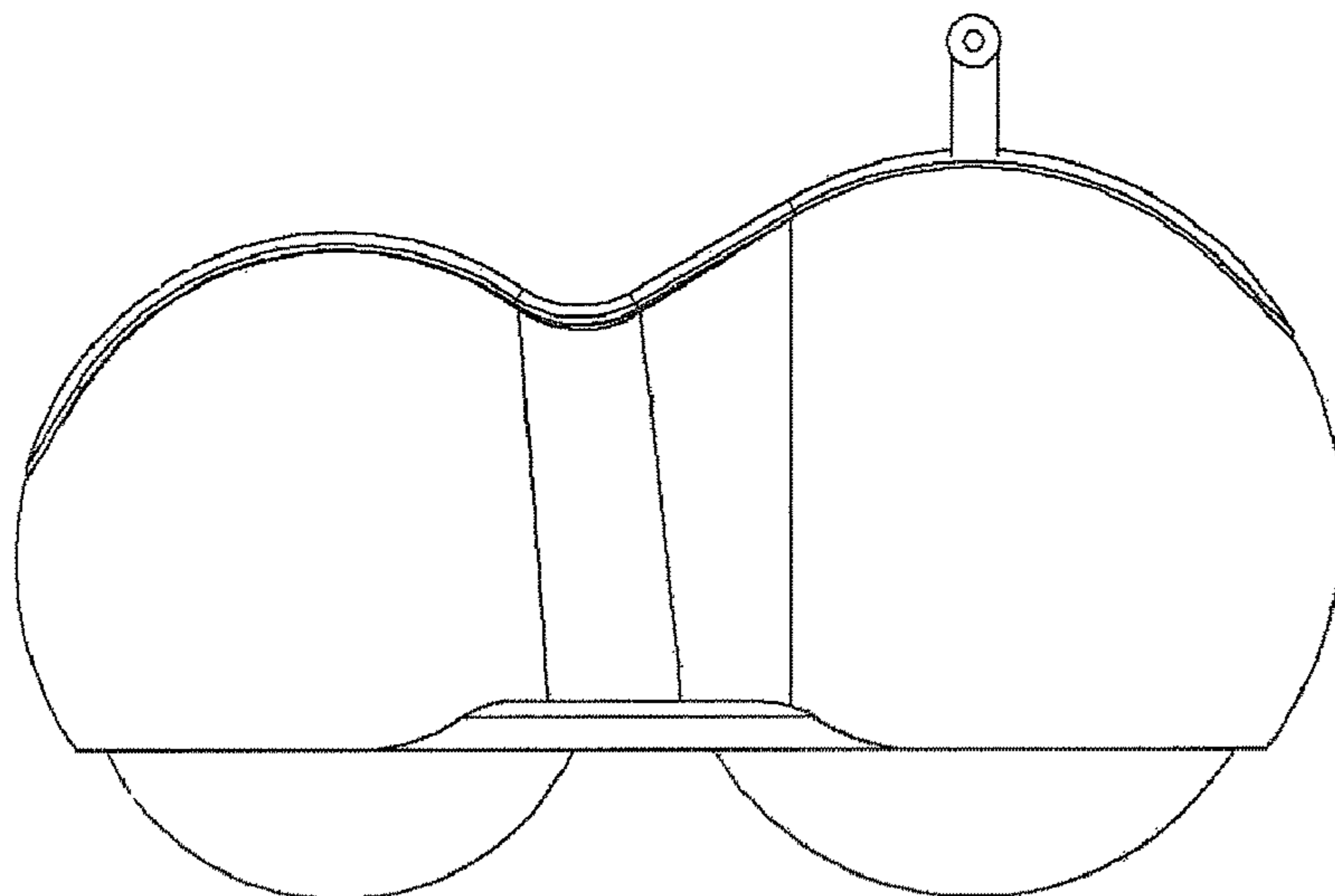

Figure 10

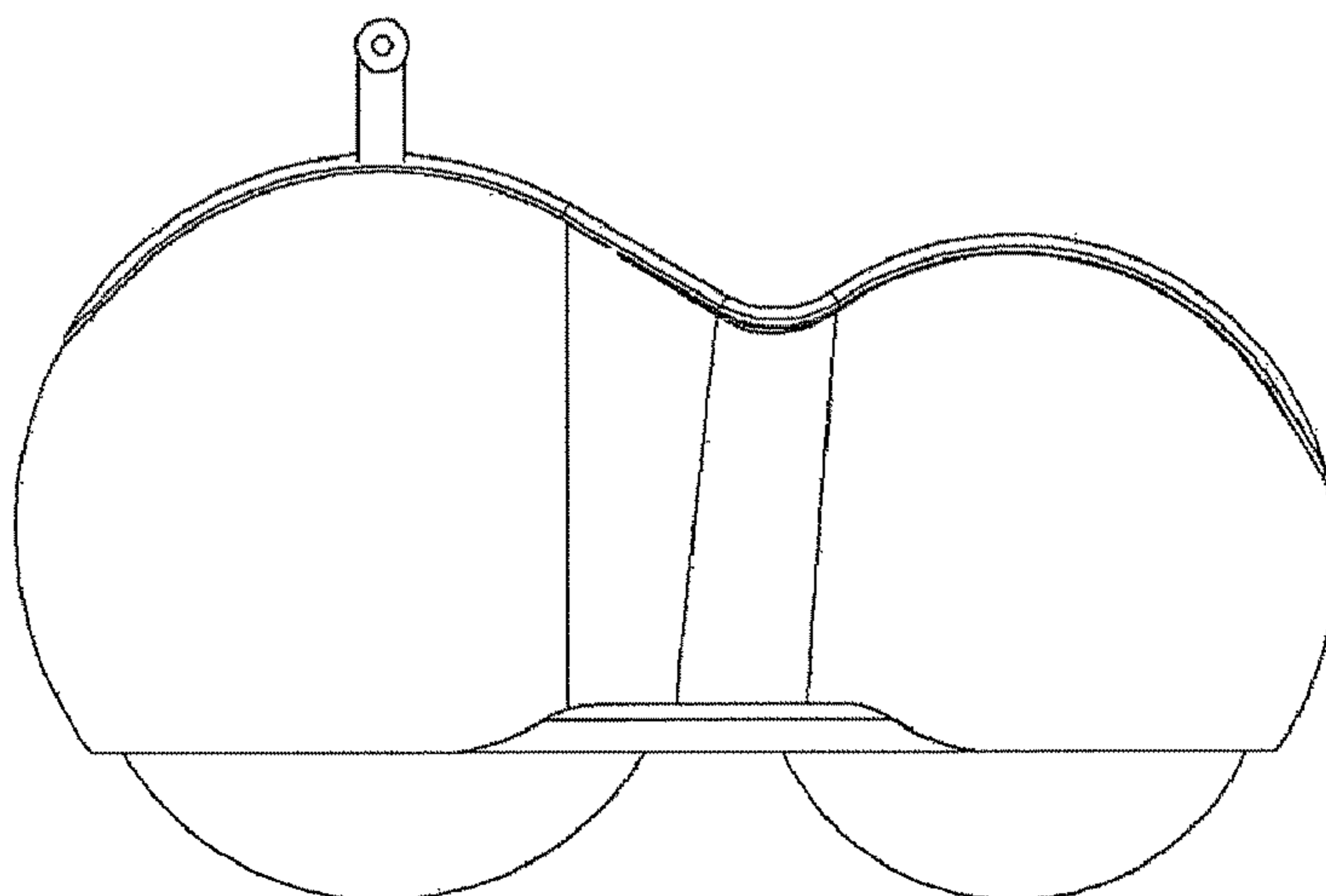

Figure 11

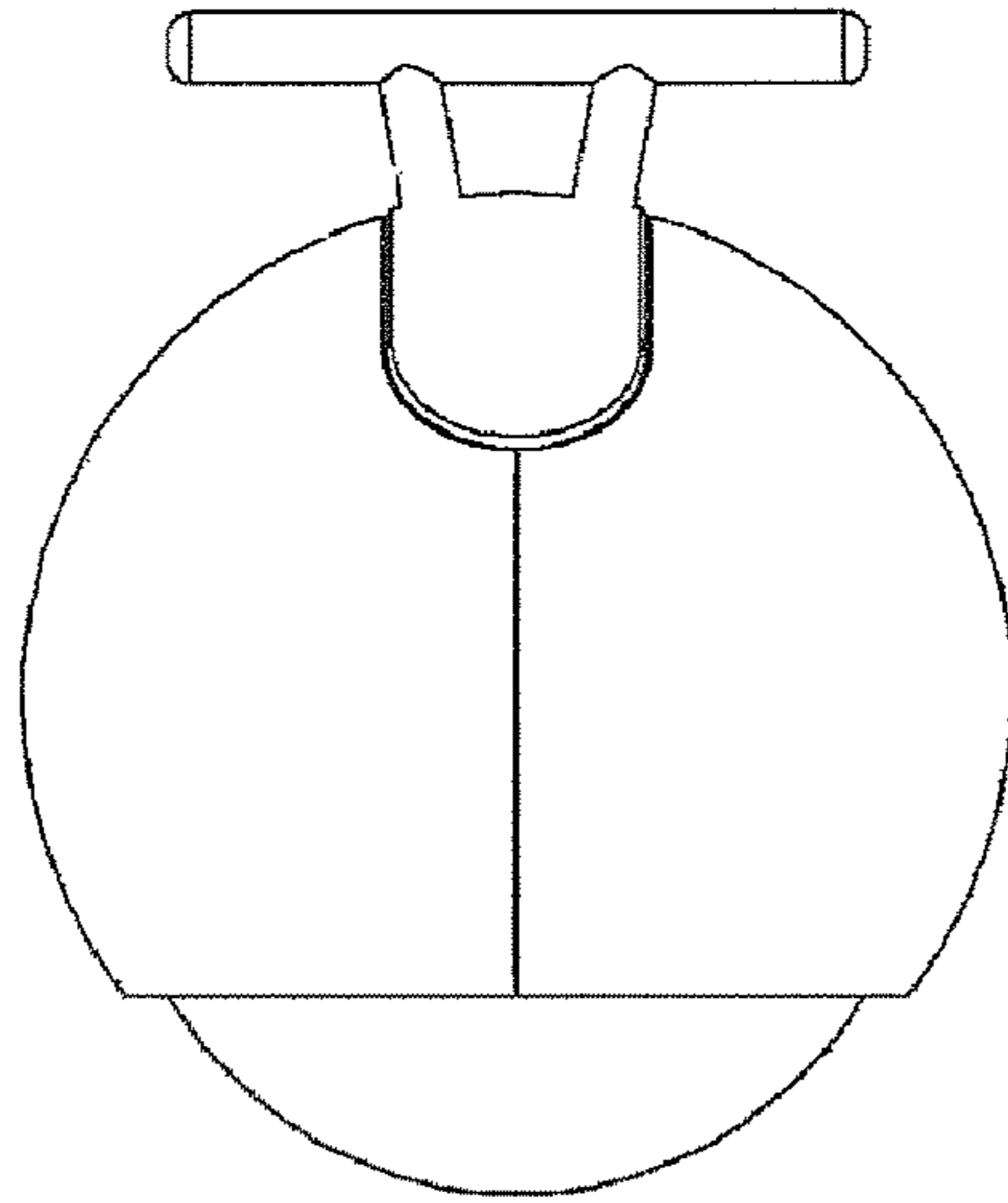

Figure 12

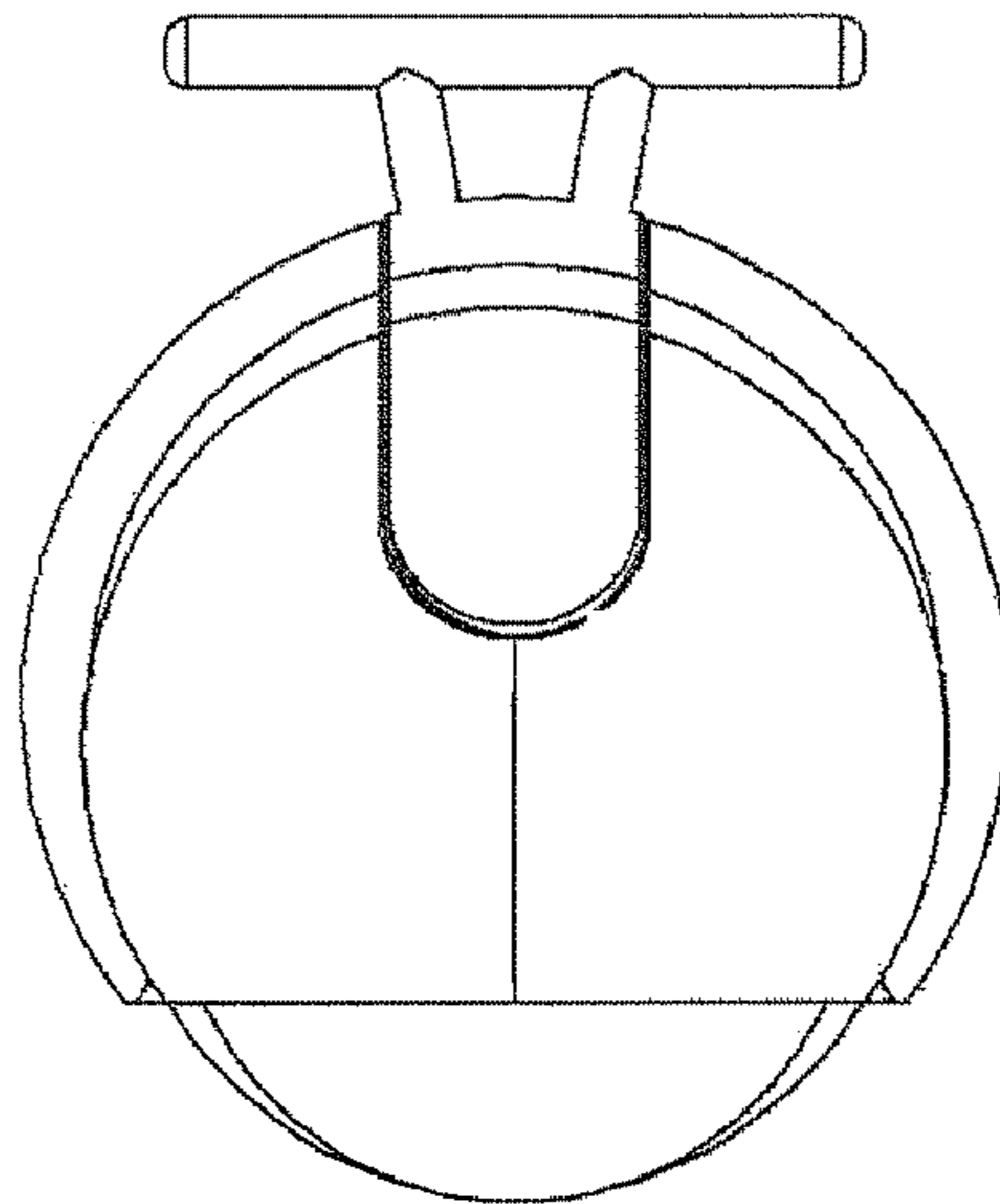

Figure 13



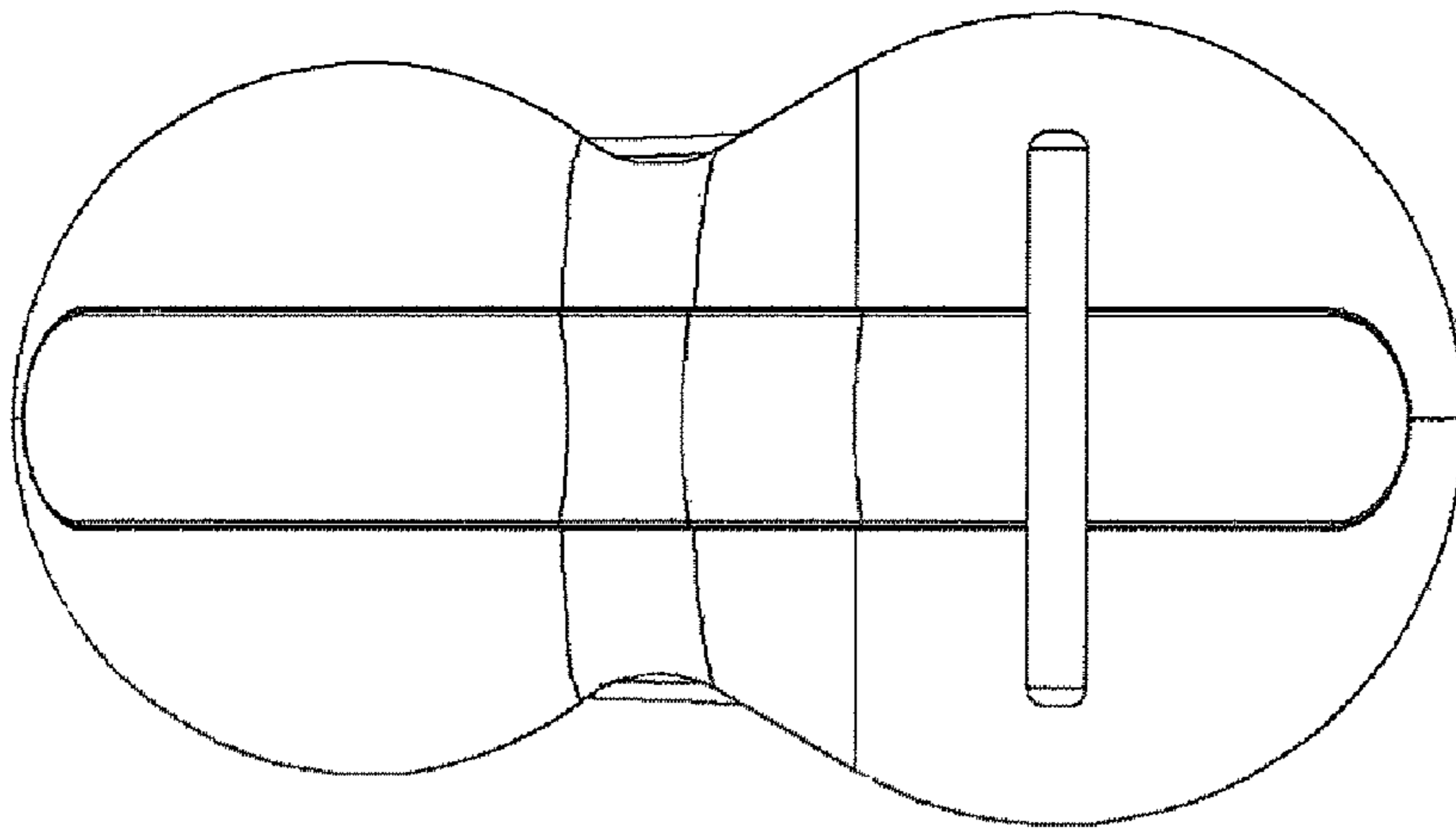

Figure 14

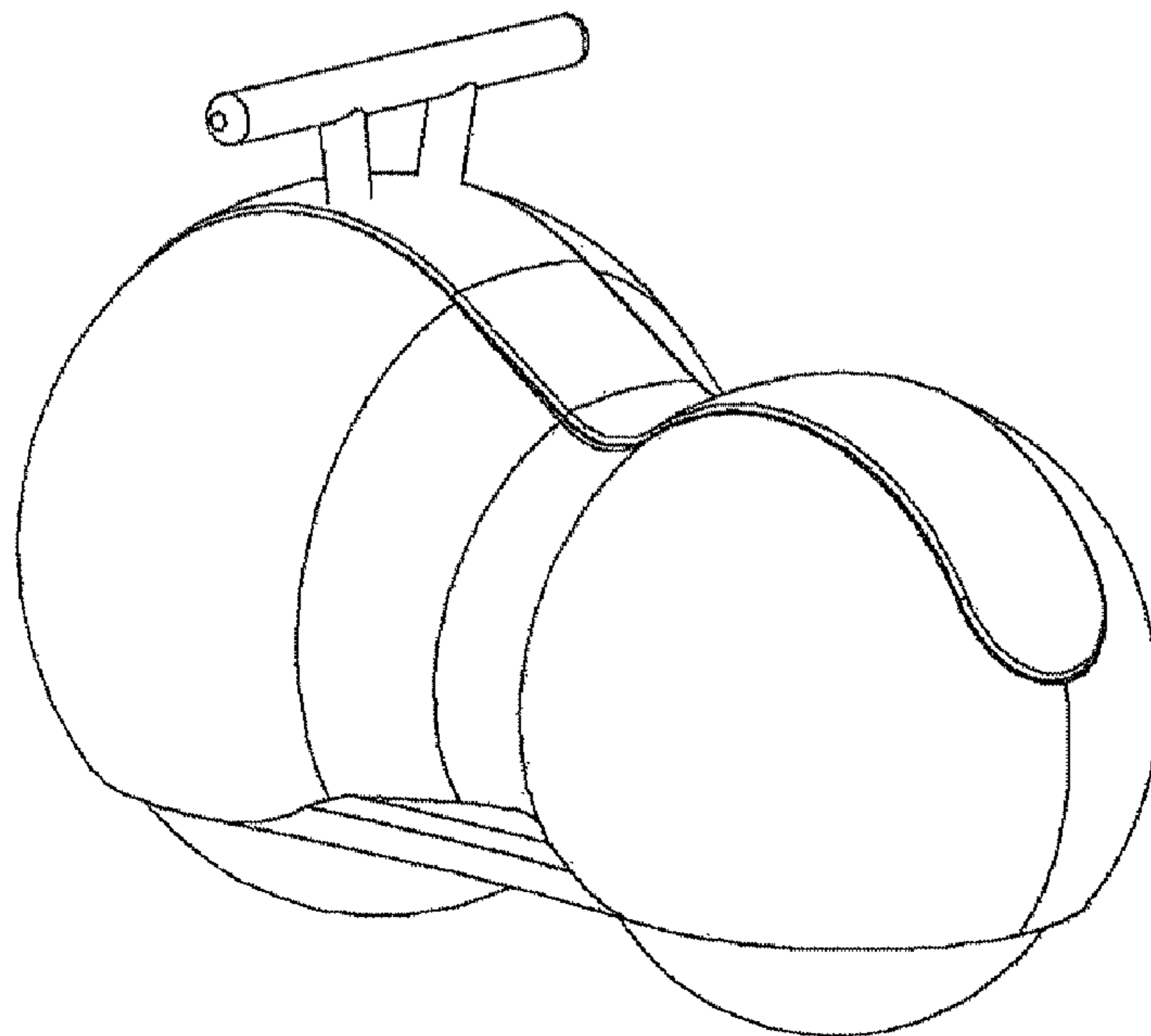

Figure 15