



US00D653270S

(12) **United States Design Patent**
Furujo et al.

(10) **Patent No.:** **US D653,270 S**
(45) **Date of Patent:** **** Jan. 31, 2012**

(54) **OUTER NOZZLE FOR PLASMA TORCH**

(75) Inventors: **Akira Furujo**, Tokyo (JP); **Masatoshi Motoyama**, Tokyo (JP); **Ryuta Hirai**, Tokyo (JP); **Kazuya Kashimata**, Isezaki (JP); **Tetsuo Koike**, Tokyo (JP)

(73) Assignee: **Koike Sanso Kogyo Co., Ltd.**, Tokyo (JP)

(**) Term: **14 Years**

(21) Appl. No.: **29/375,812**

(22) Filed: **Sep. 28, 2010**

(51) **LOC (9) Cl.** **15-09**

(52) **U.S. Cl.** **D15/144**

(58) **Field of Classification Search** D15/144-144.2;
219/121.4-121.5, 121.52, 121.57

See application file for complete search history.

(56) **References Cited**

U.S. PATENT DOCUMENTS

D369,648	S	*	5/1996	Fowler	D23/213
5,747,767	A	*	5/1998	Severance et al.	219/121.5
5,856,647	A	*	1/1999	Luo	219/121.5
D446,231	S	*	8/2001	Kuraoka et al.	D15/144
D517,577	S	*	3/2006	Conway et al.	D15/144
D527,401	S	*	8/2006	Mizuno et al.	D15/144
D535,673	S	*	1/2007	Conway et al.	D15/144
D535,674	S	*	1/2007	Conway et al.	D15/144
7,161,111	B2	*	1/2007	Schneider	219/121.4
D582,950	S	*	12/2008	Yamaguchi et al.	D15/144
D582,952	S	*	12/2008	Yamaguchi et al.	D15/144
2002/0162826	A1	*	11/2002	Eickhoff et al.	219/121.39
2005/0000948	A1	*	1/2005	Brasseur et al.	219/121.5
2005/0082263	A1	*	4/2005	Koike et al.	219/121.49
2007/0145022	A1	*	6/2007	Hewett et al.	219/121.48
2008/0251503	A1	*	10/2008	Noujaim	219/121.47

2009/0057277	A1	*	3/2009	Renault et al.	219/121.5
2009/0230095	A1	*	9/2009	Liebold et al.	219/121.5
2009/0314202	A1	*	12/2009	Zajchowski et al.	118/620
2010/0018954	A1	*	1/2010	Hussary et al.	219/121.44
2010/0206853	A1	*	8/2010	Hussary et al.	219/121.5
2010/0237050	A1	*	9/2010	Zehavi	219/121.47
2010/0264120	A1	*	10/2010	Reinke et al.	219/121.5

* cited by examiner

Primary Examiner — Patricia Palasik

(74) *Attorney, Agent, or Firm* — Townsend & Banta

(57) **CLAIM**

The ornamental design for an outer nozzle for plasma torch, as shown and described.

DESCRIPTION

FIG. 1 is a side view of an outer nozzle for a plasma torch showing our design;

FIG. 2 is a front view thereof;

FIG. 3 is a rear view thereof;

FIG. 4 is a cross-sectional view thereof, taken along line 4-4 as shown in FIG. 1;

FIG. 5 is a cross-sectional view thereof, taken along line 5-5 as shown in FIG. 3;

FIG. 6 is a perspective view of an outer nozzle for a plasma torch showing our design; and,

FIG. 7 is an exploded view of a plasma torch, inner cap therefor, inner nozzle therefor, inner cap therefor, electrode therefor, and the outer nozzle for same as claimed herein shown in broken lines, illustrating the position of the outer nozzle relative to same.

In particular, the claimed article is a body of a plasma torch used for high temperature cutting applications, such as the cutting of metal.

The broken lines in the drawings depict unclaimed environmental subject matter.

1 Claim, 7 Drawing Sheets

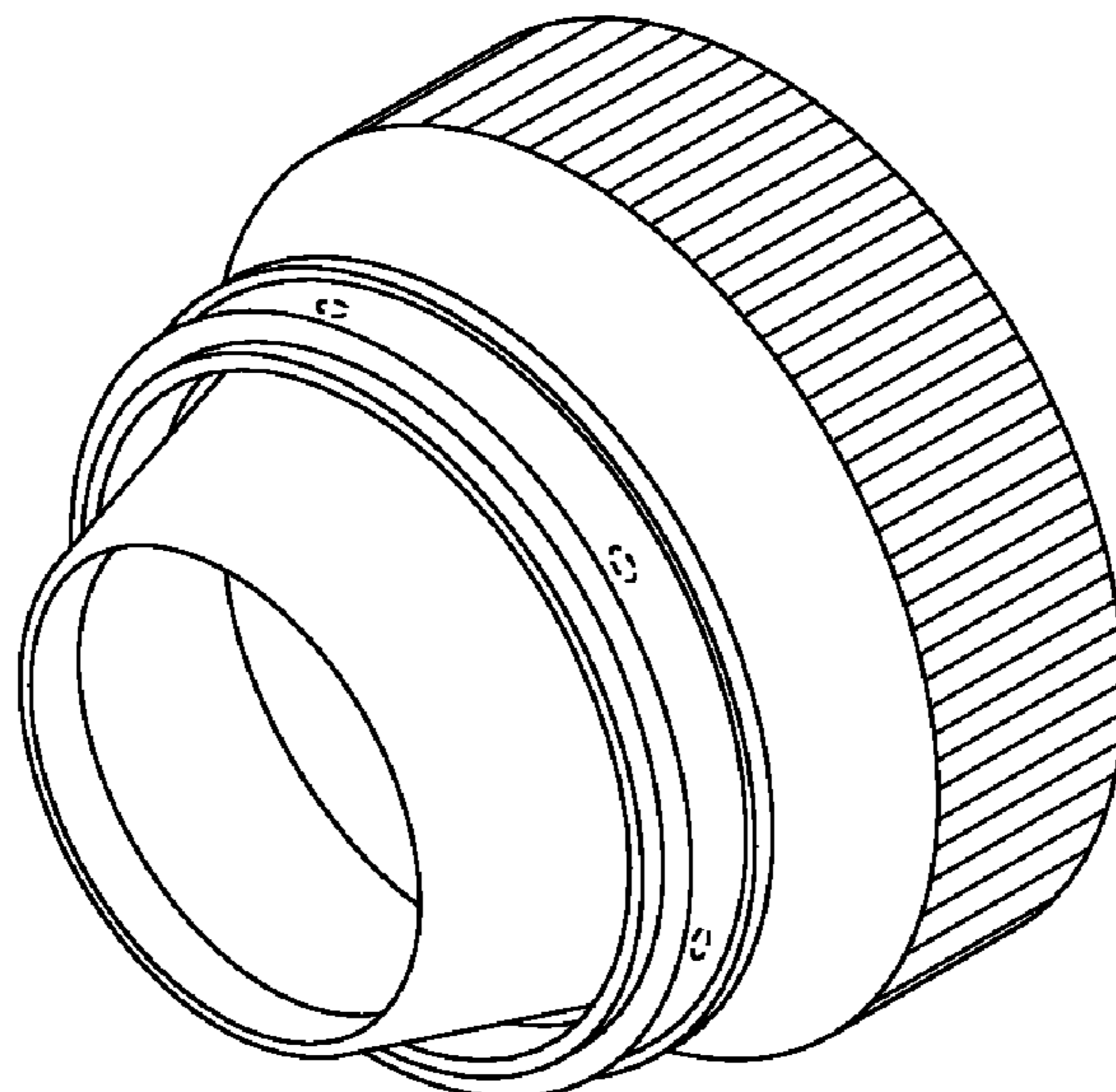

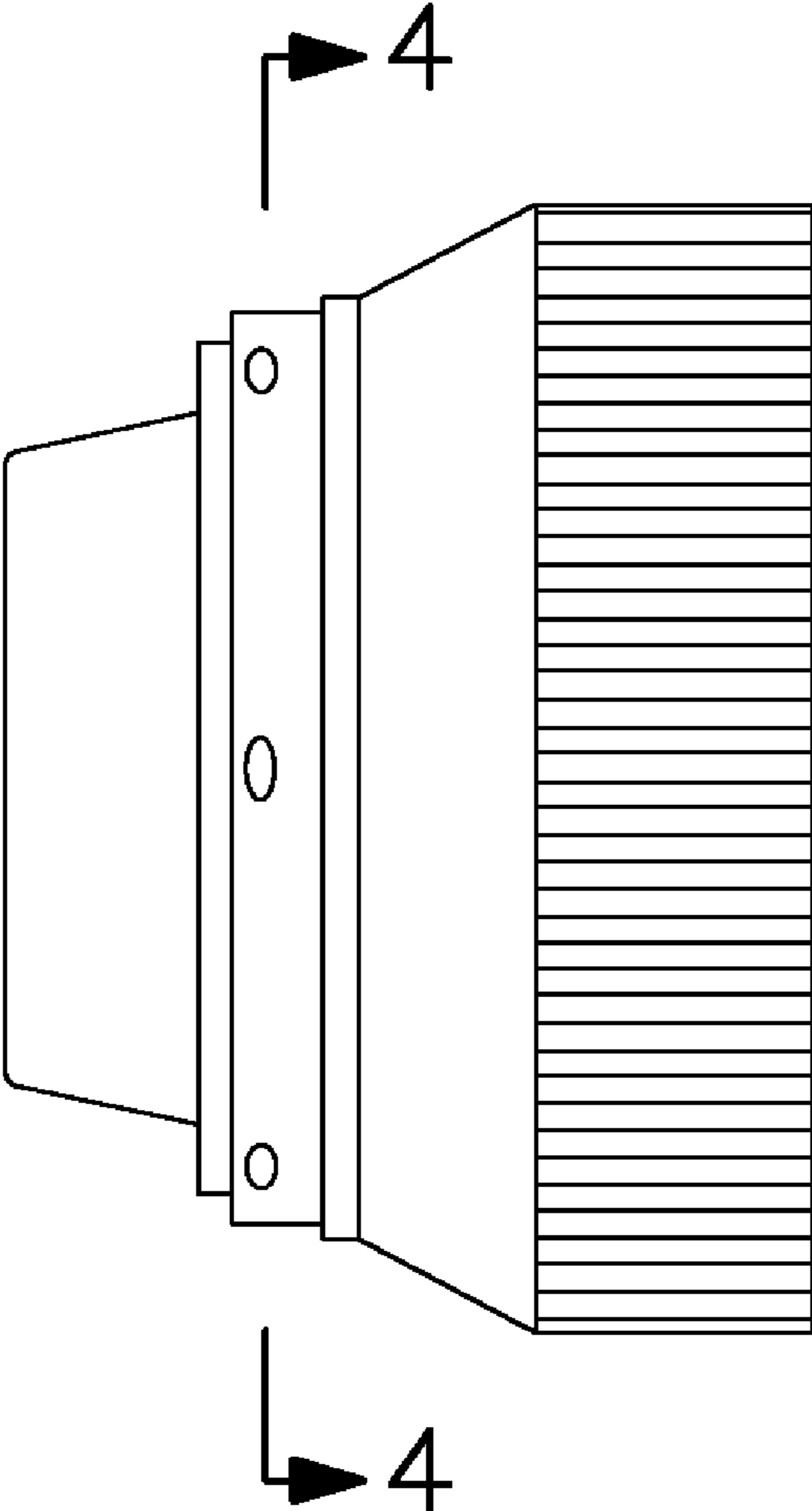

FIG. 1

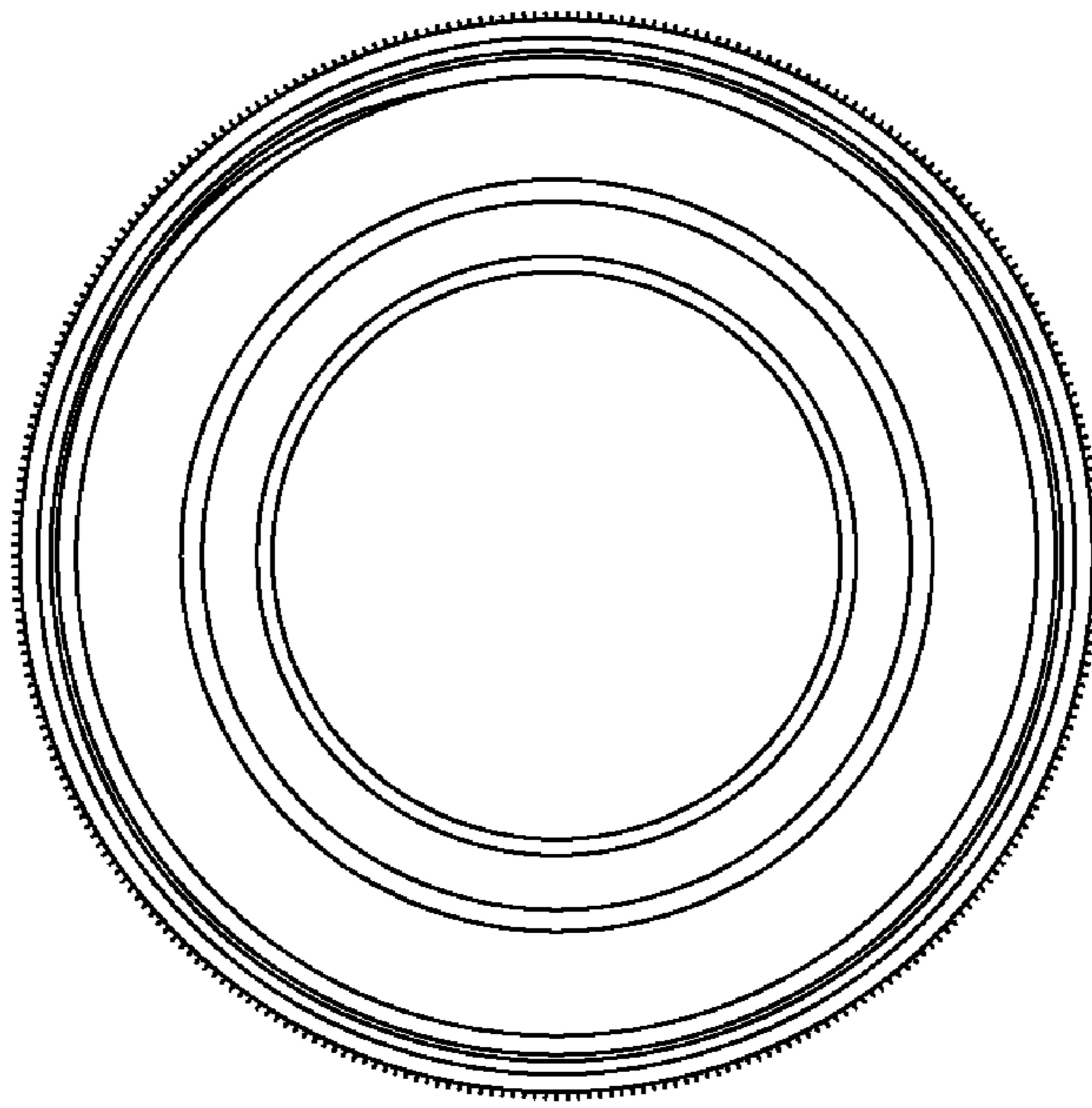

FIG. 2

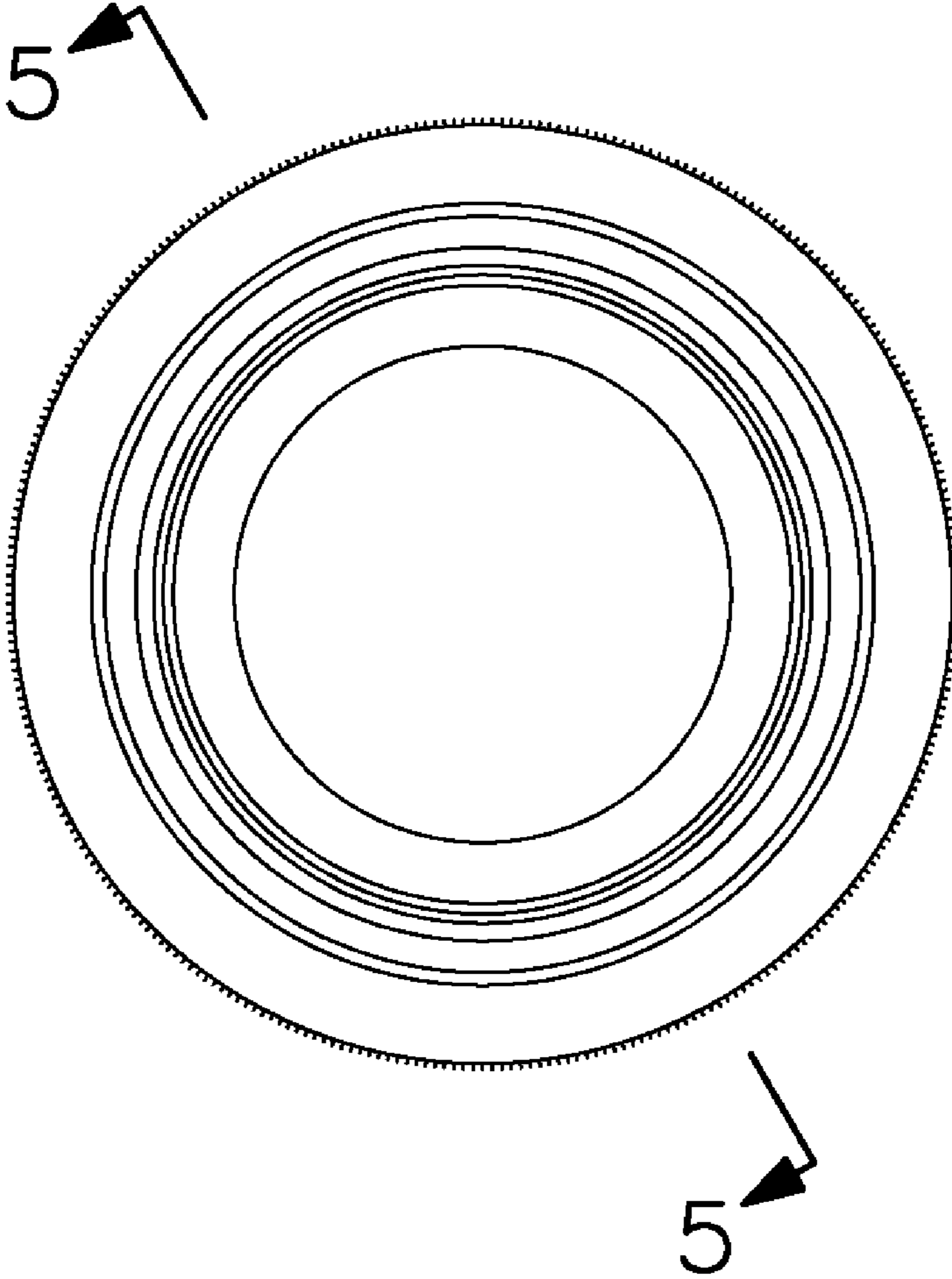

FIG. 3

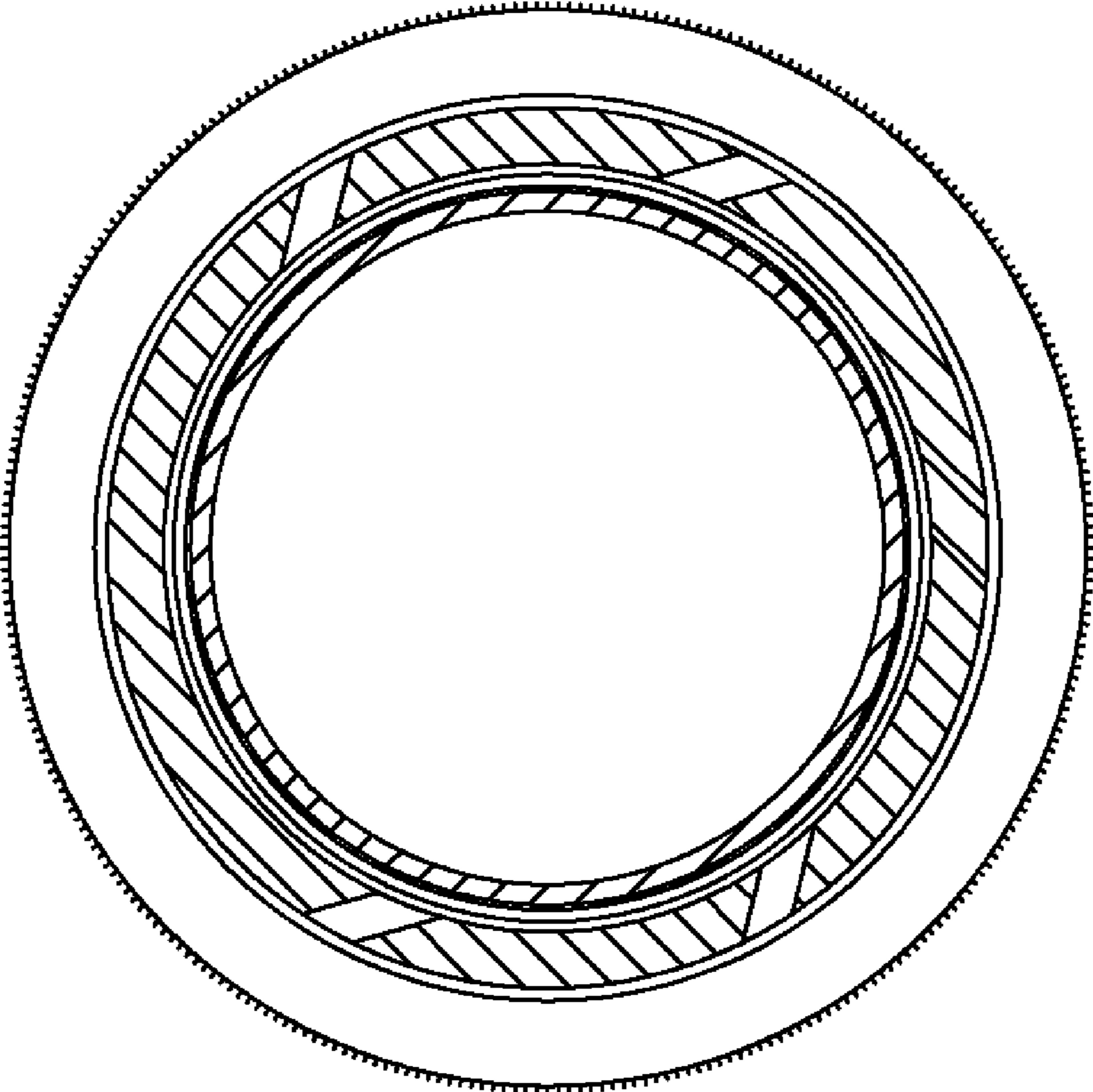

FIG. 4

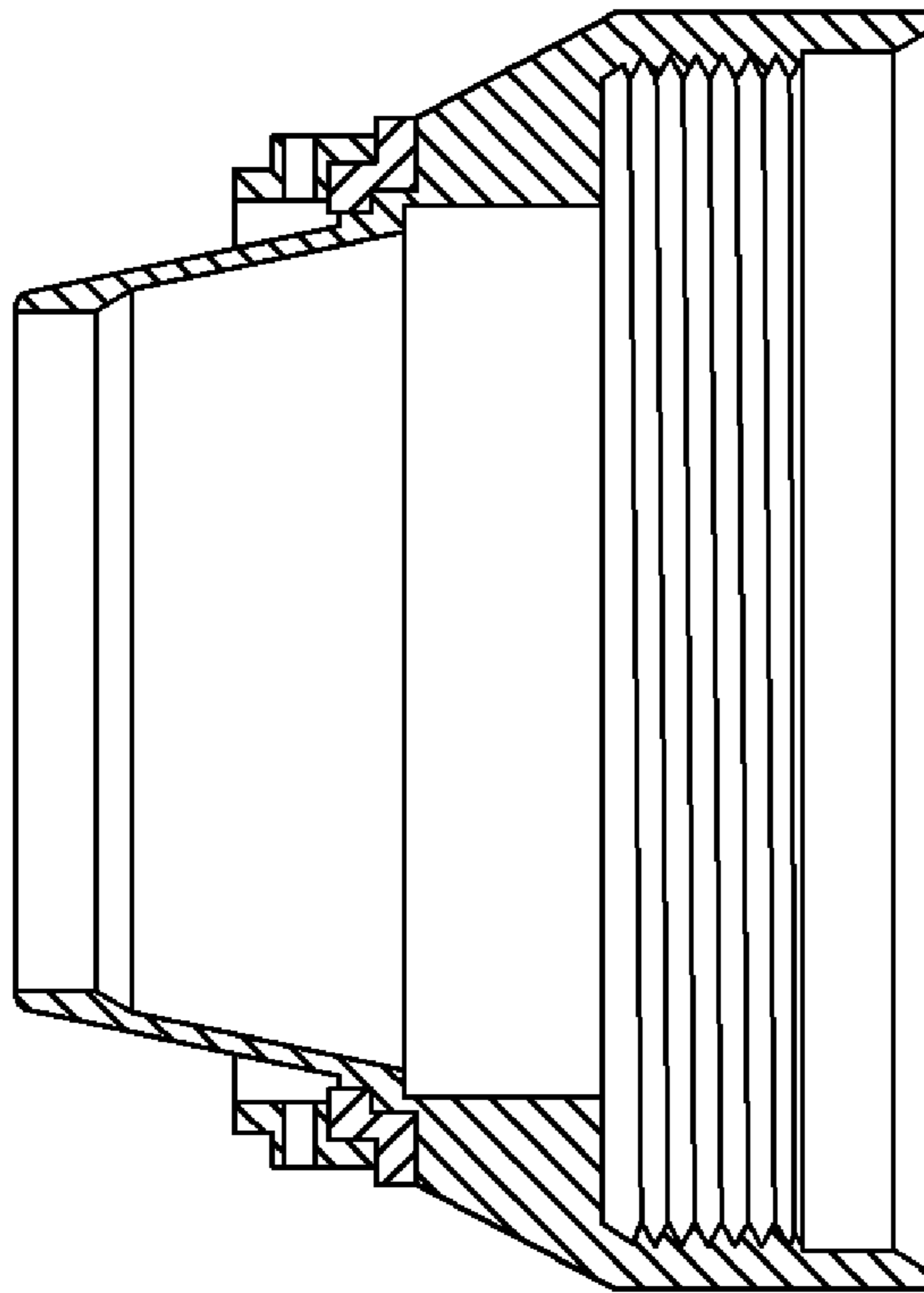

FIG. 5

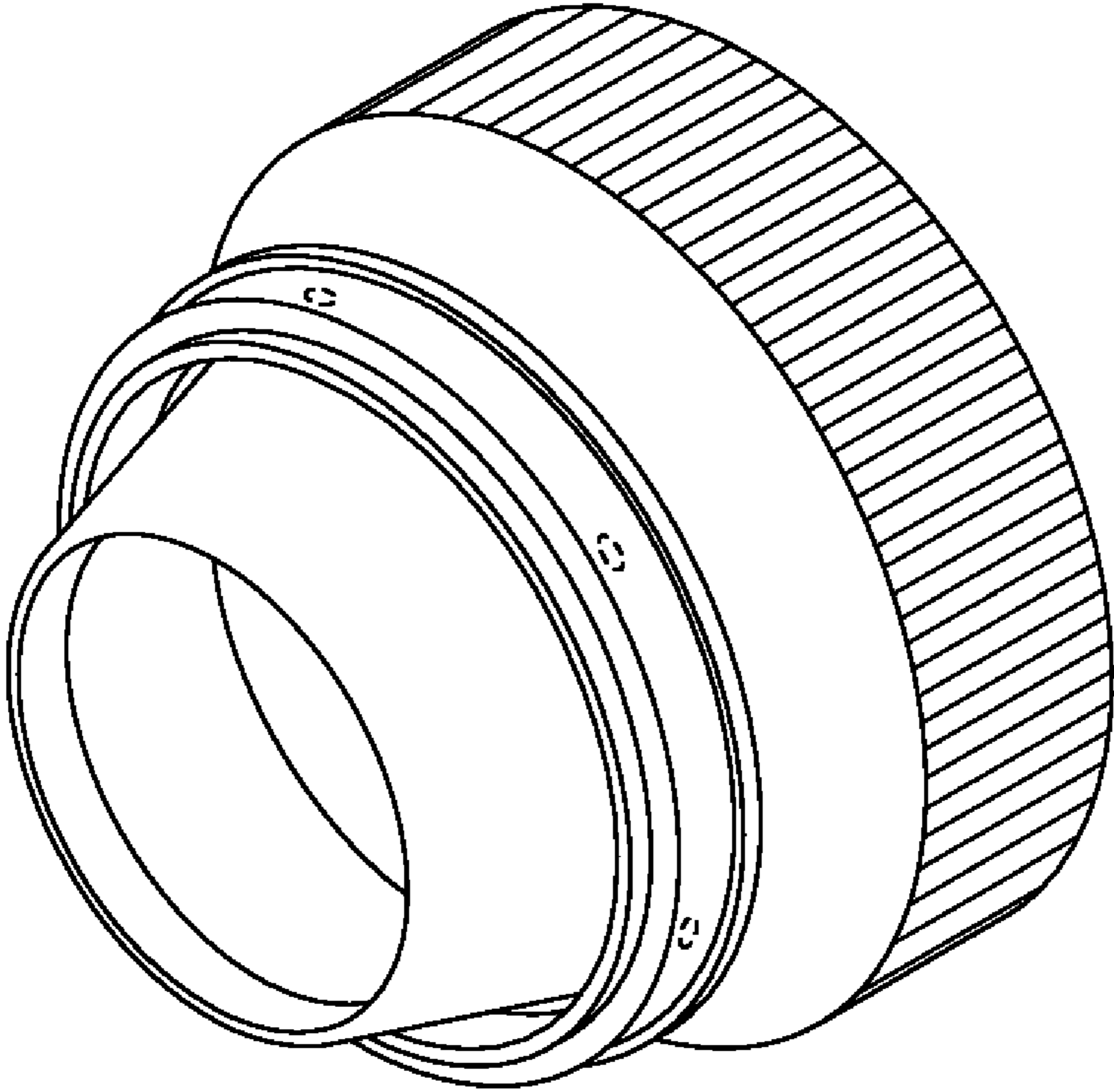

FIG. 6

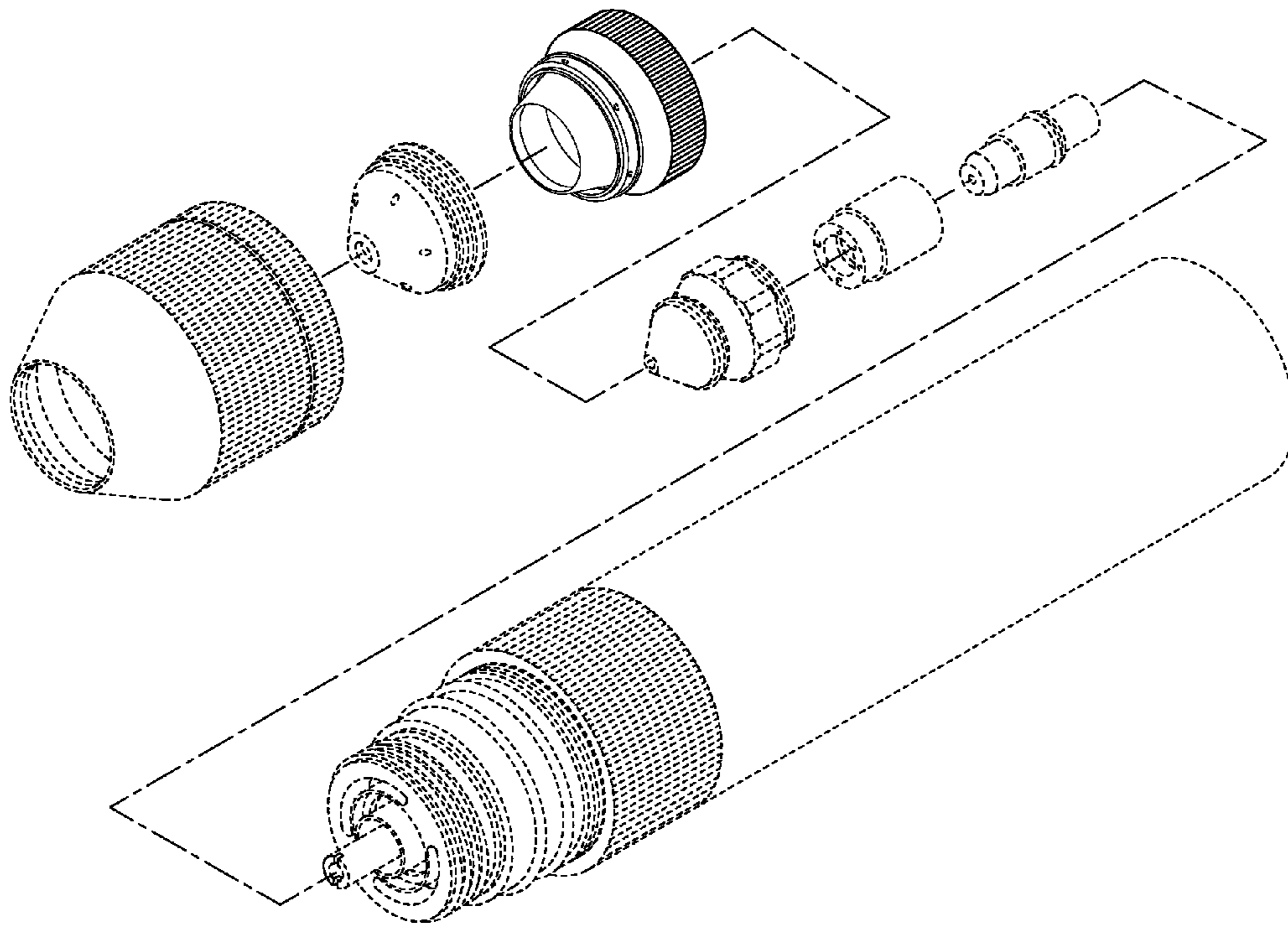

FIG. 7