



US00D653245S

(12) **United States Design Patent**  
**Buzzard et al.**

(10) **Patent No.:** **US D653,245 S**  
(45) **Date of Patent:** **\*\* Jan. 31, 2012**

(54) **VIDEO UNIT WITH INTEGRATED FEATURES**

3,909,121 A 9/1975 De Mesquita Cardoso  
(Continued)

(75) Inventors: **Kyle A. Buzzard**, San Jose, CA (US);  
**Andrew R. Church**, Oakland, CA (US);  
**Ashok T. Desai**, Fremont, CA (US);  
**Daniel K. Harden**, Palo Alto, CA (US);  
**Torence Lu**, Fremont, CA (US);  
**Richard T. Wales**, Sunnyvale, CA (US);  
**Christopher L. Whittall**, Los Gatos, CA (US)

FOREIGN PATENT DOCUMENTS  
CN 101953158(A) 1/2011  
(Continued)

(73) Assignee: **Cisco Technology, Inc.**, San Jose, CA (US)

**OTHER PUBLICATIONS**

U.S. Appl. No. 12/366,593, filed Feb. 5, 2009, entitled "System and Method for Depth Perspective Image Rendering," Inventor(s): J. William Mauchly et al.

(\*\*) Term: **14 Years**

(Continued)

(21) Appl. No.: **29/389,654**

*Primary Examiner* — Raphael Barkai  
*Assistant Examiner* — Randall Gholson  
(74) *Attorney, Agent, or Firm* — Patent Capital Group

(22) Filed: **Apr. 14, 2011**

(57) **CLAIM**

The ornamental design for a video unit with integrated features, as shown and described.

**Related U.S. Application Data**

(62) Division of application No. 29/375,458, filed on Sep. 22, 2010, now Pat. No. Des. 636,359, which is a division of application No. 29/358,008, filed on Mar. 21, 2010, now Pat. No. Des. 626,103.

**DESCRIPTION**

(51) **LOC (9) Cl.** ..... **14-03**  
(52) **U.S. Cl.** ..... **D14/239**  
(58) **Field of Classification Search** ..... D14/447,  
D14/451, 452, 239, 432, 434, 439, 448, 457,  
D14/251, 253, 224, 224.1, 126, 127, 371,  
D14/373, 374, 375; D8/363, 373, 380; 248/917,  
248/918, 919, 920, 921, 922, 923, 924, 441.1,  
248/460, 122.1, 125.7, 371, 176.1, 176.3,  
248/222.52, 276.1, 324; 361/679.06, 679.04,  
361/679.21, 679.22, 679.56

FIG. 1 is a top perspective view showing a video unit with integrated features design according to another embodiment; FIG. 2 is a front view of the video unit with integrated features design of FIG. 1; FIG. 3 is a back view of the video unit with integrated features design of FIG. 1; FIG. 4 is a side view of the video unit with integrated features design of FIG. 1; FIG. 5 is another side view of the video unit with integrated features design of FIG. 1; FIG. 6 is a top view of the video unit with integrated features design of FIG. 1; FIG. 7 is a bottom view of the video unit with integrated features design of FIG. 1; and, FIG. 8 is a rear perspective view thereof.

See application file for complete search history.

The broken lines of the preceding FIGURES illustrate a boundary and, further, the broken lines are for illustration only and form no part of the claimed design.

(56) **References Cited**

**U.S. PATENT DOCUMENTS**

2,911,462 A 11/1959 Brady  
3,793,489 A 2/1974 Sank

**1 Claim, 6 Drawing Sheets**

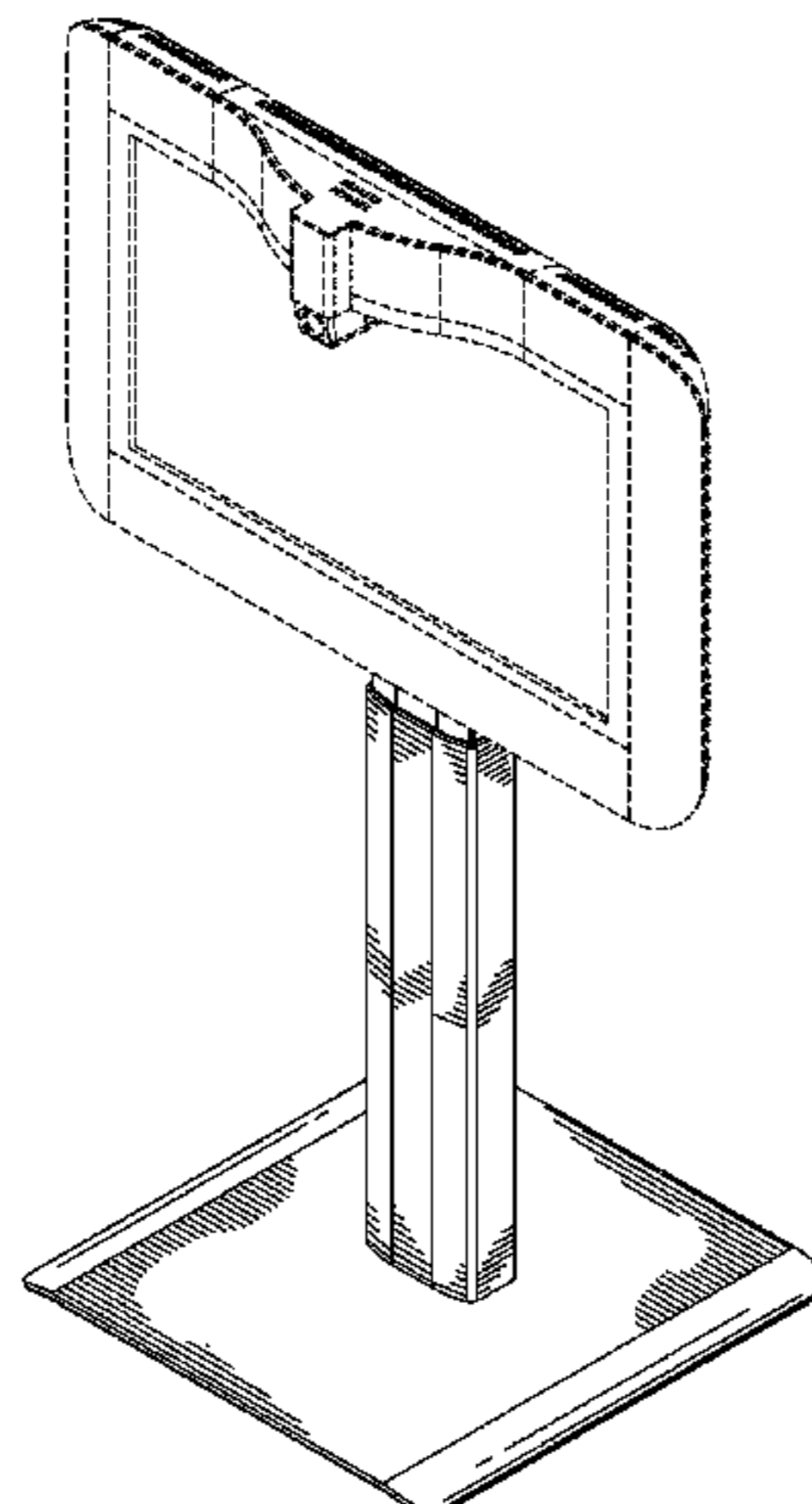

# US D653,245 S

U.S. PATENT DOCUMENTS							
4,400,724	A	8/1983	Fields	6,980,526	B2	12/2005	Jang et al.
4,494,144	A	1/1985	Brown	6,989,836	B2	1/2006	Ramsey
4,750,123	A	6/1988	Christian	6,989,856	B2	1/2006	Firestone et al.
4,815,132	A	3/1989	Minami	6,990,086	B1	1/2006	Holur et al.
4,853,764	A	8/1989	Sutter	7,002,973	B2	2/2006	MeLampy et al.
4,890,314	A	12/1989	Judd et al.	7,028,092	B2	4/2006	MeLampy et al.
4,961,211	A	10/1990	Tsugane et al.	7,031,311	B2	4/2006	MeLampy et al.
5,020,098	A	5/1991	Celli	7,043,528	B2	5/2006	Schmitt et al.
5,136,652	A	8/1992	Jibbe et al.	7,057,636	B1	6/2006	Cohen-Solal et al.
5,187,571	A	2/1993	Braun et al.	7,057,662	B2	6/2006	Malzbender
5,200,818	A	4/1993	Neta et al.	7,061,896	B2	6/2006	Jabbari et al.
5,249,035	A	9/1993	Yamanaka	7,080,157	B2	7/2006	McCanne
5,255,211	A	10/1993	Redmond	7,092,002	B2	8/2006	Ferren et al.
5,268,734	A	12/1993	Parker et al.	7,111,045	B2	9/2006	Kato et al.
5,317,405	A	5/1994	Kuriki et al.	7,136,651	B2	11/2006	Kalavade
5,337,363	A	8/1994	Platt	D533,525	S	12/2006	Arie
5,347,363	A	9/1994	Yamanaka	D533,852	S	12/2006	Ma
D357,468	S	* 4/1995	Rodd ..... D14/375	D534,511	S	1/2007	Maeda et al.
5,406,326	A	4/1995	Mowry	D535,954	S	1/2007	Hwang et al.
5,423,554	A	6/1995	Davis	7,158,674	B2	1/2007	Suh
5,446,834	A	8/1995	Deering	7,161,942	B2	1/2007	Chen et al.
5,448,287	A	9/1995	Hull	D539,243	S	3/2007	Chiu et al.
5,467,401	A	11/1995	Nagamitsu et al.	D541,773	S	5/2007	Chong et al.
5,495,576	A	2/1996	Ritchey	D542,247	S	5/2007	Kinoshita et al.
5,502,481	A	3/1996	Dentinger et al.	D545,314	S	* 6/2007	Kim ..... D14/375
5,532,737	A	7/1996	Braun	7,246,118	B2	7/2007	Chastain et al.
5,541,639	A	7/1996	Takatsuki et al.	D550,635	S	9/2007	DeMaio et al.
5,541,773	A	7/1996	Kamo et al.	D551,184	S	9/2007	Kanou et al.
5,572,248	A	11/1996	Allen et al.	7,269,292	B2	9/2007	Steinberg
5,625,410	A	4/1997	Washino et al.	7,274,555	B2	* 9/2007	Kim et al. .... 361/679.27
5,666,153	A	9/1997	Copeland	D555,610	S	11/2007	Yang et al.
5,675,374	A	10/1997	Kohda	D561,130	S	* 2/2008	Won et al. .... D14/126
5,715,377	A	2/1998	Fukushima et al.	7,336,299	B2	2/2008	Kostrzewski
D391,935	S	* 3/1998	Sakaguchi et al. .... D14/375	D567,202	S	4/2008	Rieu Piquet
5,729,471	A	3/1998	Jain et al.	7,352,809	B2	4/2008	Wenger et al.
5,737,011	A	4/1998	Lukacs	7,353,279	B2	4/2008	Durvasula et al.
5,748,121	A	5/1998	Romriell	7,359,731	B2	4/2008	Choksi
5,760,826	A	6/1998	Nayar	7,411,975	B1	8/2008	Mohaban
5,790,182	A	8/1998	Hilaire	7,413,150	B1	* 8/2008	Hsu ..... 248/123.11
5,815,196	A	9/1998	Alshawi	7,428,000	B2	9/2008	Cutler et al.
D410,447	S	* 6/1999	Chang ..... D14/375	D578,496	S	10/2008	Leonard
5,940,118	A	8/1999	Van Schyndel	7,471,320	B2	12/2008	Malkin et al.
5,940,530	A	8/1999	Fukushima et al.	7,477,657	B1	1/2009	Murphy et al.
5,953,052	A	9/1999	McNelley et al.	D588,560	S	3/2009	Mellingen et al.
5,956,100	A	9/1999	Gorski	7,518,051	B2	4/2009	Redmann
6,101,113	A	8/2000	Paice	D592,621	S	* 5/2009	Han ..... D14/126
6,124,896	A	9/2000	Kurashige	7,532,232	B2	5/2009	Shah et al.
6,148,092	A	11/2000	Qian	7,545,761	B1	6/2009	Kalbag
6,167,162	A	12/2000	Jacquin et al.	D602,453	S	10/2009	Ding et al.
6,172,703	B1	1/2001	Lee	7,616,226	B2	11/2009	Roessler et al.
6,173,069	B1	1/2001	Daly et al.	D610,560	S	2/2010	Chen
6,226,035	B1	5/2001	Korein et al.	7,679,639	B2	3/2010	Harrell et al.
6,243,130	B1	6/2001	McNelley et al.	7,692,680	B2	4/2010	Graham
6,249,318	B1	6/2001	Girod et al.	7,707,247	B2	4/2010	Dunn et al.
6,266,082	B1	7/2001	Yonezawa et al.	D615,514	S	5/2010	Mellingen et al.
6,285,392	B1	9/2001	Satoda et al.	7,710,448	B2	5/2010	De Beer et al.
6,356,589	B1	3/2002	Gebler et al.	7,710,450	B2	5/2010	Dhuey et al.
6,424,377	B1	7/2002	Driscoll, Jr.	D626,102	S	10/2010	Buzzard et al.
6,430,222	B1	8/2002	Okadia	D626,103	S	10/2010	Buzzard et al.
6,493,032	B1	12/2002	Wallerstein et al.	D628,175	S	11/2010	Desai et al.
6,507,356	B1	1/2003	Jackel et al.	D628,968	S	12/2010	Desai et al.
6,583,808	B2	6/2003	Boulanger et al.	7,889,851	B2	2/2011	Shah et al.
6,593,956	B1	7/2003	Potts et al.	D635,569	S	* 4/2011	Park ..... D14/374
6,680,856	B2	1/2004	Schreiber	D635,975	S	* 4/2011	Seo et al. .... D14/374
6,704,048	B1	3/2004	Malkin et al.	7,939,959	B2	5/2011	Wagoner
6,710,797	B1	3/2004	McNelley et al.	7,990,422	B2	8/2011	Ahiska et al.
6,751,106	B2	6/2004	Zhang et al.	2002/0140804	A1	10/2002	Colmenarez et al.
6,771,303	B2	8/2004	Zhang et al.	2002/0149672	A1	10/2002	Clapp et al.
6,774,927	B1	8/2004	Cohen et al.	2002/0186528	A1	12/2002	Huang
6,795,108	B2	9/2004	Jarboe et al.	2003/0048218	A1	3/2003	Milnes et al.
6,798,834	B1	9/2004	Murakami et al.	2003/0072460	A1	4/2003	Gonopolskiy et al.
6,806,898	B1	10/2004	Toyama et al.	2003/0149724	A1	8/2003	Chang
6,807,280	B1	10/2004	Stroud et al.	2003/0160861	A1	8/2003	Barlow et al.
6,882,358	B1	4/2005	Schuster et al.	2004/0061787	A1	4/2004	Liu et al.
6,888,358	B2	5/2005	Lechner et al.	2004/0091232	A1	5/2004	Appling, III
6,917,271	B2	7/2005	Zhang et al.	2004/0118984	A1	* 6/2004	Kim et al. .... 248/149
6,922,718	B2	7/2005	Chang	2004/0119814	A1	6/2004	Clisham et al.
6,963,653	B1	11/2005	Miles	2004/0164858	A1	8/2004	Lin
				2004/0165060	A1	8/2004	McNelley et al.

2004/0178955	A1	9/2004	Menache et al.
2004/0246962	A1	12/2004	Kopeikin et al.
2004/0254982	A1	12/2004	Hoffman et al.
2004/0260796	A1	12/2004	Sundqvist et al.
2005/0007954	A1	1/2005	Sreemanthula et al.
2005/0024484	A1	2/2005	Leonard
2005/0050246	A1	3/2005	Lakkakorpi et al.
2005/0081160	A1	4/2005	Wee et al.
2005/0110867	A1	5/2005	Schulz
2005/0117022	A1	6/2005	Marchant
2005/0147257	A1	7/2005	Melchior et al.
2005/0248652	A1	11/2005	Firestone et al.
2005/0268823	A1	12/2005	Bakker et al.
2006/0017807	A1	1/2006	Lee et al.
2006/0028983	A1	2/2006	Wright
2006/0056056	A1	3/2006	Ahiska et al.
2006/0066717	A1	3/2006	Miceli
2006/0082643	A1	4/2006	Richards
2006/0093128	A1	5/2006	Oxford
2006/0100004	A1	5/2006	Kim et al.
2006/0104470	A1	5/2006	Akino
2006/0120307	A1	6/2006	Sahashi
2006/0125691	A1	6/2006	Menache et al.
2006/0126878	A1	6/2006	Takumai et al.
2006/0152489	A1	7/2006	Sweetser et al.
2006/0152575	A1	7/2006	Amiel et al.
2006/0170769	A1	8/2006	Zhou
2006/0256187	A1	11/2006	Sheldon et al.
2006/0284786	A1	12/2006	Takano et al.
2007/0039030	A1	2/2007	Romanowich et al.
2007/0121353	A1	5/2007	Zhang et al.
2007/0140337	A1	6/2007	Lim et al.
2007/0206556	A1	9/2007	Yegani et al.
2007/0217406	A1	9/2007	Riedel et al.
2008/0077390	A1	3/2008	Nagao
2008/0240237	A1	10/2008	Tian et al.
2008/0240571	A1	10/2008	Tian et al.
2008/0303901	A1	12/2008	Variyath et al.
2009/0009593	A1	1/2009	Cameron et al.
2009/0051756	A1	2/2009	Trachtenberg
2009/0122867	A1	5/2009	Mauchly et al.
2009/0207233	A1	8/2009	Mauchly et al.
2009/0207234	A1	8/2009	Chen et al.
2009/0244257	A1	10/2009	MacDonald et al.
2009/0256901	A1	10/2009	Mauchly et al.
2009/0322082	A1	12/2009	Wagoner
2009/0324023	A1	12/2009	Tian et al.
2010/0082557	A1	4/2010	Gao et al.
2010/0123770	A1	5/2010	Friel et al.
2010/0171808	A1	7/2010	Harrell et al.
2010/0208078	A1	8/2010	Tian et al.
2010/0225732	A1	9/2010	De Beer et al.
2010/0225735	A1	9/2010	Shaffer et al.
2010/0283829	A1	11/2010	De Beer et al.
2010/0302345	A1	12/2010	Baldino et al.
2011/0037636	A1	2/2011	Alexander

FOREIGN PATENT DOCUMENTS

CN	102067593	5/2011
EP	0 650 299	10/1994
EP	0 714 081	11/1995
EP	0 740 177	4/1996
EP	1 178 352 A1	6/2002
EP	1 589 758 A1	10/2005
EP	1701308 A2	9/2006
EP	1768058 A2	3/2007
EP	2073543 A1	6/2009
EP	2255531	12/2010
EP	22777308	1/2011
GB	2 294 605 A	5/1996
GB	2355876 A	5/2001
WO	WO 94/16517	7/1994
WO	WO 96/21321	7/1996
WO	WO 97/08896	3/1997
WO	WO 98/47291	10/1998
WO	WO 99/59026	11/1999
WO	WO 2005/013001 A2	2/2005
WO	WO 2005/031001 A3	2/2005
WO	WO2007/106157	9/2007

WO	WO2007/123946	11/2007
WO	WO 2007/123960 A2	11/2007
WO	WO 2007/123960 A3	11/2007
WO	WO 2008/040258	4/2008
WO	WO 2008/101117 A1	8/2008
WO	WO 2008/118887 A2	10/2008
WO	WO 2008/118887 A3	10/2008
WO	WO 2009/102503 A2	8/2009
WO	WO 2009/102503 A3	8/2009
WO	WO 2009/120814 A2	10/2009
WO	WO 2009/120814 A3	10/2009
WO	WO 2010/059481	5/2010
WO	WO2010/096342	8/2010
WO	WO 2010/104765	9/2010
WO	WO 2010/132271	11/2010

OTHER PUBLICATIONS

U.S. Appl. No. 12/727,089, filed Mar. 18, 2010, entitled "System and Method for Enhancing Video Images in a Conferencing Environment," Inventor: Joseph T. Friel.

U.S. Appl. No. 12/781,722, filed May 17, 2010, entitled "System and Method for Providing Retracting Optics in a Video Conferencing Environment," Inventor(s): Joseph T. Friel, et al.

U.S. Appl. No. 12/877,833, filed Sep. 8, 2010, entitled "System and Method for Skip Coding During Video Conferencing in a Network Environment," Inventor[s]: Dihong Tian, et al.

U.S. Appl. No. 12/870,687, filed Aug. 27, 2010, entitled "System and Method for Producing a Performance Via Video Conferencing in a Network Environment," Inventor(s): Michael A. Arnao et al.

U.S. Appl. No. 12/912,556, filed Oct. 26, 2010, entitled "System and Method for Provisioning Flows in a Mobile Network Environment," Inventors: Balaji Vankat Vankataswami, et al.

U.S. Appl. No. 12/949,614, filed Nov. 18, 2010, entitled "System and Method for Managing Optics in a Video Environment," Inventors: Torrence Lu, et al.

U.S. Appl. No. 12/873,100, filed Aug. 31, 2010, entitled "System and Method for Providing Depth Adaptive Video Conferencing," Inventor(s): J. William Mauchly et al.

U.S. Appl. No. 12/946,679, filed Nov. 15, 2010, entitled "System and Method for Providing Camera Functions in a Video Environment," Inventors: Peter A.J. Fornell, et al.

U.S. Appl. No. 12/946,695, filed Nov. 15, 2010, entitled "System and Method for Providing Enhanced Audio in a Video Environment," Inventors: Wei Li, et al.

U.S. Appl. No. 12/907,914, filed Oct. 19, 2010, entitled "System and Method for Providing Videomail in a Network Environment," Inventors: David J. Mackie et al.

U.S. Appl. No. 12/950,786, filed Nov. 19, 2010, entitled "System and Method for Providing Enhanced Video Processing in a Network Environment," Inventor[s]: David J. Mackie.

U.S. Appl. No. 12/907,919, filed Oct. 19, 2010, entitled "System and Method for Providing Connectivity in a Network Environment," Inventors: David J. Mackie et al.

U.S. Appl. No. 12/946,704, filed Nov. 15, 2010, entitled "System and Method for Providing Enhanced Graphics in a Video Environment," Inventors: John M. Kanalakis, Jr., et al.

U.S. Appl. No. 12/957,116, filed Nov. 30, 2010, entitled "System and Method for Gesture Interface Control," Inventors: Shuan K. Kirby, et al.

U.S. Appl. No. 13/036,925, filed Feb. 28, 2011, entitled "System and Method for Selection of Video Data in a Video Conference Environment," Inventor(s) Sylvia Olayinka Aya Manfa N'guessan.

U.S. Appl. No. 12/907,925, filed Oct. 19, 2010, entitled "System and Method for Providing a Pairing Mechanism in a Video Environment," Inventors: Gangfeng Kong et al.

U.S. Appl. No. 12/939,037, filed Nov. 3, 2010, entitled "System and Method for Managing Flows in a Mobile Network Environment," Inventors: Balaji Venkat Vankataswami et al.

U.S. Appl. No. 12/946,709, filed Nov. 15, 2010, entitled "System and Method for Providing Enhanced Graphics in a Video Environment," Inventors: John M. Kanalakis, Jr., et al.

U.S. Appl. No. 12/784,257, filed May 20, 2010, entitled "Implementing Selective Image Enhancement," Inventors: Dihong Tian et al.

- U.S. Appl. No. 29/375,624, filed Sep. 24, 2010, entitled "Mounted Video Unit," Inventor(s): Ashok T. Desai et al.
- U.S. Appl. No. 29/375,627, filed Sep. 24, 2010, entitled "Mounted Video Unit," Inventor(s): Ashok T. Desai et al.
- U.S. Appl. No. 29/369,951, filed Sep. 15, 2010, entitled "Video Unit With Integrated Features," Inventor(s): Kyle A. Buzzard et al.
- U.S. Appl. No. 29/375,458, filed Sep. 22, 2010, entitled "Video Unit With Integrated Features," Inventor(s): Kyle A. Buzzard et al.
- U.S. Appl. No. 29/375,619, filed Sep. 24, 2010, entitled "Freestanding Video Unit," Inventor(s): Ashok T. Desai et al.
- U.S. Appl. No. 29/381,245, filed Dec. 16, 2010, entitled "Interface Element," Inventor(s): John M. Kanalakis, Jr., et al.
- U.S. Appl. No. 29/381,250, filed Dec. 16, 2010, entitled "Interface Element," Inventor(s): John M. Kanalakis, Jr., et al.
- U.S. Appl. No. 29/381,254, filed Dec. 16, 2010, entitled "Interface Element," Inventor(s): John M. Kanalakis, Jr., et al.
- U.S. Appl. No. 29/381,256, filed Dec. 16, 2010, entitled "Interface Element," Inventor(s): John M. Kanalakis, Jr., et al.
- U.S. Appl. No. 29/381,259, filed Dec. 16, 2010, entitled "Interface Element," Inventor(s): John M. Kanalakis, Jr., et al.
- U.S. Appl. No. 29/381,260, filed Dec. 16, 2010, entitled "Interface Element," Inventor(s): John M. Kanalakis, Jr., et al.
- U.S. Appl. No. 29/381,262, filed Dec. 16, 2010, entitled "Interface Element," Inventor(s): John M. Kanalakis, Jr., et al.
- U.S. Appl. No. 29/381,264, filed Dec. 16, 2010, entitled "Interface Element," Inventor(s): John M. Kanalakis, Jr., et al.
- PCT "International Search Report and the Written Opinion of the International Searching Authority, or the Declaration," PCT/US2010/026456, dated Jun. 29, 2010; 11 pages.
- PCT "Notification of Transmittal of the International Search Report and the Written Opinion of the International Searching Authority, or the Declaration," PCT/US2009/001070, dated Apr. 4, 2009; 14 pages.
- PCT "Notification of Transmittal of the International Search Report and the Written Opinion of the International Searching Authority, or the Declaration," PCT/US2009/038310; dated Oct. 10, 2009; 17 pages.
- PCT "International Preliminary Report on Patentability and Written Opinion of the International Searching Authority," PCT/US2009/038310; dated Sep. 28, 2010; 10 pages.
- PCT "International Preliminary Report on Patentability dated Sep. 29, 2009, International Search Report, and Written Opinion," for PCT International Application PCT/US2008/058079; dated Sep. 18, 2008, 10 pages.
- "3D Particles Experiments in AS3 and Flash CS3," [retrieved and printed on Mar. 18, 2010]; 2 pages; <http://www.flashandmath.com/advanced/fourparticles/notes.html>.
- 3G, "World's First 3G Video Conference Service with New TV Commercial," Apr. 28, 2005, 4 pages; <http://www.3g.co.uk/PR/April2005/1383.htm>.
- Digital Video Enterprises, "DVE Eye Contact Silhouette," 1 page, © DVE 2008; <http://www.dvetelepresence.com/products/eyeContactSilhouette.asp>.
- France Telecom R&D, "France Telecom's Magic Telepresence Wall—Human Productivity Lab," 5 pages, retrieved and printed on May 17, 2010; [http://www.humanproductivitylab.com/archive\\_blogs/2006/07/11/france\\_telecoms\\_magic\\_telepres\\_1.php](http://www.humanproductivitylab.com/archive_blogs/2006/07/11/france_telecoms_magic_telepres_1.php).
- Joshua Gluckman and S.K. Nayar, "Rectified Catadioptric Stereo Sensors," 8 pages, retrieved and printed on May 17, 2010; <http://cis.poly.edu/~gluckman/papers/cvpr00.pdf>.
- R.V. Kollarits, et al., "34.3: An Eye Contact Camera/Display System for Videophone Applications Using a Conventional Direct-View LCD," © 1995 SID, ISSN0097-0966X/95/2601, pp. 765-768; <http://citeseerx.ist.psu.edu/viewdoc/download;jsessionid=47A1E7E028-C26503975E633895D114EC?doi=10.1.1.42.1772&rep=rep1&type=pdf>.
- Trevor Darrell, "A Real-Time Virtual Mirror Display," 1 page, Sep. 9, 1998; <http://people.csail.mit.edu/trevor/papers/1998-021/node6.html>.
- Video on TED.com, Pranav Mistry: the Thrilling Potential of SixthSense Technology (5 pages) and Interactive Transcript (5 pages), retrieved and printed on Nov. 30, 2010; [http://www.ted.com/talks/pranav\\_mistry\\_the\\_thrilling\\_potential\\_of\\_sixthsense\\_technology.html](http://www.ted.com/talks/pranav_mistry_the_thrilling_potential_of_sixthsense_technology.html).
- "Eye Tracking," from Wikipedia, (printed on Aug. 31, 2011) 12 pages; [http://en.wikipedia.org/wiki/Eye\\_tracker](http://en.wikipedia.org/wiki/Eye_tracker).
- "RoundTable, 360 Degrees Video Conferencing Camera unveiled by Microsoft," TechShout, Jun. 30, 2006, 1 page; <http://www.techshout.com/gadgets/2006/30/roundtable-360-degrees-video-conferencing-camera-unveiled-by-microsoft/#>.
- Dornaika F., et al., "Head and Facial Animation Tracking Using Appearance-Adaptive Models and Particle Filters," 20040627; 20040627-20040602, Jun. 27, 2004, 22 pages; Heudiasy Research Lab, [http://eprints.pascal-network.org/archive/00001231/01/rvhci\\_chapter8.pdf](http://eprints.pascal-network.org/archive/00001231/01/rvhci_chapter8.pdf).
- Eisert, Peter, "Immersive 3-D Video Conferencing: Challenges, Concepts and Implementations," Proceedings of SPIE Visual Communications and Image Processing (VCIP), Lugano, Switzerland, Jul. 2003; 11 pages; <http://iphone.hhi.de/eisert/papers/vcip03.pdf>.
- EPO Aug. 15, 2011 Response to EPO Communication mailed Feb. 25, 2011 from European Patent Application No. 09725288.6; 15 pages.
- Geys et al., "Fast Interpolated Cameras by Combining a GPU Based Plane Sweep With a Max-Flow Regularisation Algorithm," Sep. 9, 2004; 3D Data Processing, Visualization and Transmission 2004, pp. 534-541.
- Hammadi, Nait Charif et al., "Tracking the Activity of Participants in a Meeting," Machine Vision and Applications, Springer, Berlin, De LnkD—DOI:10.1007/S00138-006-0015-5, vol. 17, No. 2, May 1, 2006, pp. 83-93, XP019323925 <http://citeseerx.ist.psu.edu/viewdoc/summary?doi=10.1.1.106.9832>.
- Kwolek, B., "Model Based Facial Pose Tracking Using a Particle Filter," Geometric Modeling and Imaging—New Trends, 2006 London, England Jul. 5-6, 2005, Piscataway, NJ, USA, IEEE LNKD-DOI: 10.1109/GMAI.2006.34 Jul. 5, 2006, pp. 203-208; XP010927285 [Abstract Only].
- PCT Sep. 25, 2007 Notification of Transmittal of the International Search Report from PCT/US06/45895.
- PCT Sep. 2, 2008 International Preliminary Report on Patentability (1 page) and the Written Opinion of the ISA (4 pages) from PCT/US2006/045895.
- PCT Sep. 11, 20089 Notification of Transmittal of the International Search Report from PCT/US07/09469.
- PCT Nov. 4, 2008 International Preliminary Report on Patentability (1 page) and the Written Opinion of the ISA (8 pages) from PCT/US2007/009469.
- PCT May 11, 2010 International Search Report from PCT/US2010/024059; 4 pages.
- PCT Aug. 23, 2011 International Preliminary Report on Patentability and Written Opinion of the ISA from PCT/US2010/024059; 6 pages.
- U.S. Appl. No. 13/096,772, filed Apr. 28, 2011, entitled "System and Method for Providing Enhanced Eye Gaze in a Video Conferencing Environment," Inventor(s): Charles C. Byers.
- U.S. Appl. No. 13/106,002, filed May 12, 2011, entitled "System and Method for Video Coding in a Dynamic Environment," Inventors; Dihong Tian et al.
- U.S. Appl. No. 13/098,430, filed Apr. 30, 2011, entitled "System and Method for Transferring Transparency Information in a Video Environment," Inventors: Eddie Collins et al.
- U.S. Appl. No. 13/096,795, filed Apr. 28, 2011, entitled "System and Method for Providing Enhanced Eye Gaze in a Video Conferencing Environment," Inventors: Charles C. Byers.
- EPO Feb. 25, 2011 Communication for EP09725288.6; 4 pages.
- Cumming, Jonathan, "Session Border Control in IMS, An Analysis of the Requirements for Session Border Control in IMS Networks," Sections 1.1, 1.1.1, 1.1.3, 1.1.4, 2.1.1, 3.2, 3.3.1, 5.2.3 and pp. 7-8, Data Connection, 2005.
- Jong-Good Ko et al., "Facial Feature Tracking and Head Orientation-Based Gaze Tracking," ITC-CSCC 2000, International Technical Conference on Circuits/Systems, Jul. 11-13, 2000, 4 pages, <http://www.umiacs.umd.edu/~knkim/paper/itc-cscc-2000-jgko.pdf>.
- Veratech Corp., "Phantom Sentinel," © VeratechAero 2006, 1 page; <http://www.veratechcorp.com/phantom.html>.

- U.S. Appl. No. 29/389,651, filed Apr. 14, 2011, entitled "Video Unit With Integrated Features," Inventor(s): Kyle A. Buzzard et al. Active8-3D—Holographic Projection—3D Hologram Retail Display & Video Project, [retrieved and printed on Feb. 24, 2009], [http://www.activ8-3d.co.uk/3d\\_holocubes](http://www.activ8-3d.co.uk/3d_holocubes); 1 page.
- Andersson, L., et al., "LDP Specification," Network Working Group, RFC 3036, Jan. 2001, 133 pages; <http://tools.ietf.org/html/rfc3036>.
- Arrington, Michael, "eJamming—Distributed Jamming," TechCrunch; Mar. 16, 2006; <http://www.techcrunch.com/2006/03/16/ejamming-distributed-jamming/>; 1 page.
- Avrithis, Y., et al., "Color-Based Retrieval of Facial Images," European Signal Processing Conference (EUSIPCO '00), Tampere, Finland; Sep. 2000; <http://www.image.ece.ntua.gr/~ntsap/presentations/eusipco00.ppt#256>; 18 pages.
- Awduche, D., et al., "Requirements for Traffic Engineering over MPLS," Network Working Group, RFC 2702, Sep. 1999, 30 pages; <http://tools.ietf.org/pdf/rfc2702.pdf>.
- Bakstein, Hynek, et al., "Visual Fidelity of Image Based Rendering," Center for Machine Perception, Czech Technical University, Proceedings of the Computer Vision, Winter 2004, <http://www.benogo.dk/publications/Bakstein-Pajdla-CVWW04.pdf>; 10 pages.
- Beesley, S.T.C., et al., "Active Macroblock Skipping in the H.264 Video Coding Standard," in Proceedings of 2005 Conference on Visualization, Imaging, and Image Processing—VIIP 2005, Sep. 7-9, 2005, Benidorm, Spain, Paper 480-261. ACTA Press, ISBN: 0-88986-528-0; 5 pages.
- Berzin, O., et al., "Mobility Support Using MPLS and MP-BGP Signaling," Network Working Group, Apr. 28, 2008, 60 pages; <http://www.potarco.net/ietf/all-ids/draft-berzin-malis-mpls-mobility-01.txt>.
- Boccaccio, Jeff; CEPro, "Inside HDMI CEC: The Little-Known Control Feature," Dec. 28, 2007; [http://www.cepro.com/article/print/inside\\_hdmi\\_cec\\_the\\_little\\_known\\_control\\_feature](http://www.cepro.com/article/print/inside_hdmi_cec_the_little_known_control_feature); 2 pages.
- Boros, S., "Policy-Based Network Management with SNMP," Proceedings of the EUNICE 2000 Summer School Sep. 13-15, 2000, p. 3.
- Bücken R: "Bildfernsprechen: Videoconferenz vom Arbeitsplatz aus" Funkshau, Weka Fachzeitschriften Verlag, Poing, DE, No. 17, Aug. 14, 1986, pp. 41-43, XP002537729; ISSN: 0016-2841, p. 43, left-hand column, line 34—middle column, line 24.
- Chan, Eric, et al., "Experiments on block-matching techniques for video coding," Multimedia Systems, 9 Springer-Verlag 1994, Multimedia Systems (1994) 2 pp. 228-241.
- Chen et al., "Toward a Compelling Sensation of Telepresence: Demonstrating a Portal to a Distant (Static) Office," Proceedings Visualization 2000; VIS 2000; Salt Lake City, UT, Oct. 8-13, 2000; Annual IEEE Conference on Visualization, Los Alamitos, CA: IEEE Comp. Soc., US, Jan. 1, 2000, pp. 327-333; <http://citeseerx.ist.psu.edu/viewdoc/summary?doi=10.1.1.35.1287>.
- Chen, Jason, "iBluetooth Lets iPhone Users Send and Receive Files Over Bluetooth," Mar. 13, 2009; <http://i.gizmodo.com/5169545/ibluetooth-lets-iphone-users-send-and-receive-files-over-bluetooth>; 1 page.
- Chen, Qing, et al., "Real-time Vision-based Hand Gesture Recognition Using Haar-like Features," Instrumentation and Measurement Technology Conference, Warsaw, Poland, May 1-3, 2007, 6 pages; <http://www.google.com/url?sa=t&source=web&cd=1&ved=0CB4QFjAA&url=http%3A%2F%2Fciteseerx.ist.psu.edu%2Fviewdoc%2Fdownload%3Fdoi%3D10.1.1.93.103%26rep%3Drep1%26type%3Dpdf&ei=A28RTLKRDefnQeXzZGRAw&usq=AFQjCNHpwj5MwjGp-3goVz5Wad6CO-Jzw>.
- Cisco: Bill Mauchly and Mod Marathe; UNC: Henry Fuchs, et al., "Depth-Dependent Perspective Rendering," Apr. 15, 2008; 6 pages. "Cisco Expo Germany 2009 Opening," Posted on YouTube on May 4, 2009; <http://www.youtube.com/watch?v=SKDsaSiz4MK>; 2 pages.
- Costa, Cristina, et al., "Quality Evaluation and Nonuniform Compression of Geometrically Distorted Images Using the Quadtree Distortion Map," EURASIP Journal on Applied Signal Processing, Jan. 7, 2004, vol. 2004, No. 12; © 2004 Hindawi Publishing Corp.; XP002536356; ISSN: 1110-8657; pp. 1899-1911; <http://downloads.hindawi.com/journals/asp/2004/470826.pdf>.
- Criminisi, A., et al., "Efficient Dense-Stereo and Novei-view Synthesis for Gaze Manipulation in One-to-one Teleconferencing," Technical Rpt MSR-TR-2003-59, Sep. 2003 [retrieved and printed on Feb. 26, 2009], [http://research.microsoft.com/pubs/67266/criminisi\\_techrep2003-59.pdf](http://research.microsoft.com/pubs/67266/criminisi_techrep2003-59.pdf), 41 pages.
- "Custom 3D Depth Sensing Prototype System for Gesture Control," 3D Depth Sensing, GestureTek, 3 pages; [retrieved and printed on Dec. 1, 2010] <http://www.gesturetek.com/3depth/introduction.php>.
- Daly, S., et al., "Face-based visually-optimized image sequence coding," Image Processing, 1998, ICIP 98, Proceedings; 1998 International Conference on Chicago, IL; Oct. 4-7, 1998, Los Alamitos; IEEE Computing; vol. 3, Oct. 4, 1998; ISBN: 978-0-8186-8821-8; XP010586786; pp. 443-447.
- Diaz, Jesus, "Zcam 3D Camera is Like Wii Without Wiimote and Minority Report Without Gloves," Dec. 15, 2007; <http://gizmodo.com/gadgets/zcam-depth-camera-could-be-wii-challenger/zcam-3d-camera-is-like-wii-without-wiimote-and-minority-report-without-gloves-334426.php>; 3 pages.
- Diaz, Jesus, iPhone Bluetooth File Transfer Coming Soon (Yes!); Jan. 26, 2009; <http://i.gizmodo.com/5138797/iphone-bluetooth-file-transfer-coming-soon-yes>; 1 page.
- DVE Digital Video Enterprises, "DVE Tele-immersion Room," [retrieved and printed on Feb. 5, 2009] [http://www.dvetelepresence.com/products/immersion\\_room.asp](http://www.dvetelepresence.com/products/immersion_room.asp); 2 pages.
- Dynamic Displays, copyright 2005-2008 [retrieved and printed on Feb. 24, 2009] [http://www.zebraimaging.com/html/lighting\\_display.html](http://www.zebraimaging.com/html/lighting_display.html), 2 pages.
- ECmag.com, "IBS Products," Published Apr. 2009; <http://www.ecmag.com/index.cfm?fa=article&articleID=10065>; 2 pages.
- eJamming Audio, Learn More; [retrieved and printed on May 27, 2010] <http://www.ejamming.com/learnmore/>; 4 pages.
- Electrophysics Glossary, "Infrared Cameras, Thermal Imaging, Night Vision, Roof Moisture Detection," [retrieved and printed on Mar. 18, 2010] [http://www.electrophysics.com/Browse/Brw\\_Glossary.asp](http://www.electrophysics.com/Browse/Brw_Glossary.asp); 11 pages.
- Farrukh, A., et al., Automated Segmentation of Skin-Tone Regions in Video Sequences, Proceedings IEEE Students Conference, ISCON\_\_apos\_02; Aug. 16-17, 2002; pp. 122-128.
- Fiala, Mark, "Automatic Projector Calibration Using Self-Identifying Patterns," National Research Council of Canada, Jun. 20-26, 2005; <http://www.procams.org/procams2005/papers/procams05-36.pdf>; 6 pages.
- Foote, J., et al., "Flycam: Practical Panoramic Video and Automatic Camera Control," in Proceedings of IEEE International Conference on Multimedia and Expo, vol. III, Jul. 30, 2000; pp. 1419-1422; <http://citeseerx.ist.psu.edu/viewdoc/versions?doi=10.1.1.138.8686>.
- Freeman, Professor Wilson T., Computer Vision Lecture Slides, "6.869 Advances in Computer Vision: Learning and Interfaces," Spring 2005; 21 pages.
- Gemmell, Jim, et al., "Gaze Awareness for Video-conferencing: A Software Approach," IEEE MultiMedia, Oct.-Dec. 2000; vol. 7, No. 4, pp. 26-35.
- Gotchev, Atanas, "Computer Technologies for 3D Video Delivery for Home Entertainment," International Conference on Computer Systems and Technologies; CompSysTech, Jun. 12-13, 2008; <http://ecet.ecs.ru.acad.bg/cst08/docs/cp/Plenary/P.1.pdf>; 6 pages.
- Gries, Dan, "3D Particles Experiments in AS3 and Flash CS3, Dan's Comments," [retrieved and printed on May 24, 2010] <http://www.flashandmath.com/advanced/fourparticles/notes.html>; 3 pages.
- Guernsey, Lisa, "Toward Better Communication Across the Language Barrier," Jul. 29, 1999; <http://www.nytimes.com/1999/07/29/technology/toward-better-communication-across-the-language-barrier.html>; 2 pages.
- Guill, D., et al., "Orchestral: A Distributed Platform for Virtual Musical Groups and Music Distance Learning over the Internet in Java™ Technology"; [retrieved and printed on Jun. 6, 2010] <http://ieeexplore.ieee.org/stamp/stamp.jsp?tp=&arnumber=778626>; 2 pages.
- Gundavelli, S., et al., "Proxy Mobile IPv6," Network Working Group, RFC 5213, Aug. 2008, 93 pages; <http://tools.ietf.org/pdf/rfc5213.pdf>.

- Gussenhoven, Carlos, "Chapter 5 Transcription of Dutch Intonation," Nov. 9, 2003, 33 pages; <http://www.ru.nl/publish/pages/516003/todisun-ah.pdf>.
- Habill, Nariman, et al., "Segmentation of the Face and Hands in Sign Language Video Sequences Using Color and Motion Cues" IEEE Transaction on Circuits and Systems for Video Technology, IEEE Service Center, vol. 14, No. 8, Aug. 1, 2004; ISSN: 1051-8215; XP011115755; pp. 1086-1097.
- He, L., et al., "The Virtual Cinematographer: A Paradigm for Autoamtic Real-Time Camera Control and Directing," Proc. SIGGRAPH, © 1996; <http://research.microsoft.com/en-us/um/people/ihe/papers/siggraph96.vc.pdf>; 8 pages.
- Hepper, D., "Efficiency Analysis and Application of Uncovered Background Prediction in a Low BitRate Image Coder." IEEE Transactions on Communications, vol. 38, No. 9, pp. 1578-1584, Sep. 1990.
- Hock, Hans Henrich, "Prosody vs. Syntax: Prosodic rebracketing of final vocatives in English," 4 pages; [retrieved and printed on Mar. 3, 2011] <http://speechprosody2010.illinois.edu/papers/100931.pdf>.
- Holographic Imaging, "Dynamic Holography for scientific uses, military heads up display and even someday HoloTV Using TI's DMD," [retrieved and printed on Feb. 26, 2009] [http://innovation.swmed.edu/reserach/instrumentation/res\\_inst\\_dev3d.html](http://innovation.swmed.edu/reserach/instrumentation/res_inst_dev3d.html); 5 pages.
- Hornbeck, Larry J., "Digital Light ProcessingTM: A New MEMS-Based Display Technology," [retrieved and printed on Feb. 26, 2009] [http://focus.ti.com/pdfs/dlpdmd/17\\_Digital\\_Light\\_Processing\\_MEMS\\_display\\_technology.pdf](http://focus.ti.com/pdfs/dlpdmd/17_Digital_Light_Processing_MEMS_display_technology.pdf); 22 pages.
- "Infrared Cameras TVS-200-EX," [retrieved and printed on May 24, 2010] [http://www.electrophysics.com/Browse/Brw\\_ProductLineCategory.asp?CategoryID=184&Area=IS](http://www.electrophysics.com/Browse/Brw_ProductLineCategory.asp?CategoryID=184&Area=IS); 2 pages.
- IR Distribution Category @ Envious Technology, "IR Distribution Category," [retrieved and printed on Apr. 22, 2009] <http://www.envioustechnology.com.au/products/product-list.php?CID=305>; 2 pages.
- IR Trans—Products and Orders—Ethernet Devices, [retrieved and printed on Apr. 22, 2009] <http://www.irtrans.de/en/shop/lan.php>; 2 pages.
- Isgro, Francesco et al., "Three-Dimensional Image Processing in the Future of Immersive Media," IEEE Transactions on Circuits and Systems for Video Technology, vol. 14, No. 3; XP011108796; ISSN: 1051-8215; Mar. 1, 2004; pp. 288-303.
- Itoh, Hiroyasu, et al., "Use of a gain modulating framing camera for time-resolved imaging of cellular phenomena," SPIE vol. 2979, 1997, pp. 733-740.
- Jamoussi, Bamil, "Constraint-Based LSP Setup Using LDP," MPLS Working Group, Sep. 1999, 34 pages; <http://tools.ietf.org/html/draft-ietf-mpls-cr-ldp-03>.
- Jeyatharan, M., et al., "3GPP TFT Reference for Flow Binding," MEXT Working Group, Mar. 2, 2010, 11 pages; <http://www.ietf.org/id/draft-jeyatharan-mext-flow-tftemp-reference-00.txt>.
- Jiang, Minqiang, et al., "On Lagrange Multiplier and Quantizer Adjustment for H.264 Frame-layer Video Rate Control," IEEE Transactions on Circuits and Systems for Video Technology, vol. 16, Issue 5, May 2006, pp. 663-669.
- Kannangara, C.S., et al., "Complexity Reduction of H.264 Using Lagrange Multiplier Methods," IEEE Int. Conf. on Visual Information Engineering, Apr. 2005; [www.rgu.ac.uk/files/h264\\_complexity\\_kannangara.pdf](http://www.rgu.ac.uk/files/h264_complexity_kannangara.pdf); 6 pages.
- Kannangara, C.S., et al., "Low Complexity Skip Prediction for H.264 through Lagrangian Cost Estimation," IEEE Transactions on Circuits and Systems for Video Technology, vol. 16, No. 2, Feb. 2006; [www.rgu.ac.uk/files/h264\\_skippredict\\_richardson\\_final.pdf](http://www.rgu.ac.uk/files/h264_skippredict_richardson_final.pdf); 20 pages.
- Kauff, Peter, et al., "An Immersive 3D Video-Conferencing System Using Shared Virtual Team User Environments," Proceedings of the 4th International Conference on Collaborative Virtual Environments, XP040139458; Sep. 30, 2002; [http://ip.hhi.de/imedia\\_G3/assets/pdfs/CVE02.pdf](http://ip.hhi.de/imedia_G3/assets/pdfs/CVE02.pdf); 8 pages.
- Kazutake, Uehira, "Simulation of 3D image depth perception in a 3D display using two stereoscopic displays at different depths," Jan. 30, 2006; <http://adsabs.harvard.edu/abs/2006SPIE.6055.408U>; 2 pages.
- Keijser, Jeroen, et al., "Exploring 3D Interaction in Alternate Control-Display Space Mappings," IEEE Symposium on 3D User Interfaces, Mar. 10-11, 2007, pp. 17-24.
- Kim, Y.H., et al., "Adaptive mode decision for H.264 encoder," Electronics letters, vol. 40, Issue 19, pp. 1172-1173, Sep. 2004; 2 pages.
- Klint, Josh, "Deferred Rendering in Leadwerks Engine," Copyright Leadwerks Corporation © 2008; [http://www.leadwerks.com/files/Deferred\\_Rendering\\_in\\_Leadwerks\\_Engine.pdf](http://www.leadwerks.com/files/Deferred_Rendering_in_Leadwerks_Engine.pdf); 10 pages.
- Kolsch, Mathias, "Vision Based Hand Gesture Interfaces for Wearable Computing and Virtual Environments," A Dissertation submitted in partial satisfaction of the requirements for the degree of Doctor of Philosophy in Computer Science, University of California, Santa Barbara, Nov. 2004, 288 pages; <http://fulfillment.umi.com/dissertations/b7afbcb56ba72fdb14d26dfccc6b470f/1291487062/3143800>.
- Koyama, S., et al. "A Day and Night Vision MOS Imager with Robust Photonic-Crystal-Based RGB-and-IR," Mar. 2008, pp. 754-759; ISSN: 0018-9383; IEE Transactions on Electron Devices, vol. 55, No. 3; <http://ieeexplore.ieee.org/stamp/stamp.jsp?tp=&arnumber=4455782&isnumber=4455723>.
- Lawson, S., "Cisco Plans TelePresence Translation Next Year," Dec. 9, 2008; [http://www.pcworld.com/article/155237/.html?tk=rss\\_news](http://www.pcworld.com/article/155237/.html?tk=rss_news); 2 pages.
- Lee, J. and Jeon, B., "Fast Mode Decision for H.264," ISO/IEC MPEG and ITU-T VCEG Joint Video Team, Doc. JVT-J033, Dec. 2003; [http://media.skku.ac.kr/publications/paper/intC/ljy\\_ICME2004.pdf](http://media.skku.ac.kr/publications/paper/intC/ljy_ICME2004.pdf); 4 pages.
- Liu, Z., "Head-Size Equalization for Better Visual Perception of Video Conferencing," Proceedings, IEEEInternational Conference on Multimedia & Expo (ICME2005), Jul. 6-8, 2005, Amsterdam, The Netherlands; <http://research.microsoft.com/users/cohen/HeadSizeEqualizationICME2005.pdf>; 4 pages.
- Mann, S., et al., "Virtual Bellows: Constructing High Quality Still from Video," Proceedings, First IEEE International Conference on Image Processing ICIP-94, Nov. 13-16, 1994, Austin, TX; <http://citeseerx.ist.psu.edu/viewdoc/summary?doi=10.1.1.50.8405>; 5 pages.
- Marvin Imaging Processing Framework, "Skin-colored pixels detection using Marvin Framework," video clip, YouTube, posted Feb. 9, 2010 by marvinproject, 1 page; <http://www.youtube.com/user/marvinproject#p/a/u/0/3ZuQHYNlcr1>.
- Miller, Gregor, et al., "Interactive Free-Viewpoint Video," Centre for Vision, Speech and Signal Processing, [retrieved and printed on Feb. 26, 2009], <http://www.ee.surrey.ac.uk/CVSSP/VMRG/Publications/miller05cvmp.pdf>, 10 pages.
- Miller, Paul, "Microsoft Research patents controller-free computer input via EMG muscle sensors," Engadget.com, Jan. 3, 2010, 1 page; <http://www.engadget.com/2010/01/03/microsoft-research-patents-controller-free-computer-input-via-em/>.
- Minoru from Novo is the worlds first consumer 3D Webcam, Dec. 11, 2008; <http://www.minoru3d.com>; 4 pages.
- Mitsubishi Electric Research Laboratories, copyright 2009 [retrieved and printed on Feb. 26, 2009], <http://www.merl.com/projects/3dtv>, 2 pages.
- National Training Systems Association Home—Main, Interservice/Industry Training, Simulation & Education Conference, Dec. 1-4, 2008; <http://ntsa.metapress.com/app/home/main.asp?referrer=default>; 1 page.
- Oh, Hwang-Seok, et al., "Block-Matching Algorithm Based on Dynamic Search Window Adjustment," Dept. of CS, KAIST, 1997, 6 pages; <http://citeseerx.ist.psu.edu/viewdoc/similar?doi=10.1.1.29.8621&type=ab>.
- Opera Over Cisco TelePresence at Cisco Expo 2009, in Hannover Germany—Apr. 28, 29, posted on YouTube on May 5, 2009; <http://www.youtube.com/watch?v=xNSjNH5E-38>; 1 page.
- OptoIQ, "Vision + Automation Products—VideometerLab 2," [retrieved and printed on Mar. 18, 2010], <http://www.optoiq.com/optoiq-2/en-us/index/machine-vision-imaging-processing/display/vsd-articles-tools-template.articles.vision-systems-design.volume-11.issue-10.departments.new-products.vision-automation-products.htmlhtml>; 11 pages.
- OptoIQ, "Anti-Speckle Techniques Uses Dynamic Optics," Jun. 1, 2009; <http://www.optoiq.com/index/photronics-technologies-applications/lfw-display/lfw-article-display/363444/articles/optoiq2/>

- photonics-technologies/technology-products/optical-components/optical-mems/2009/12/anti-speckle-technique-uses-dynamic-optics/QP129867/cmpid=EnlOptoI.FWJanuary132010.html; 2 pages.
- OptoIQ, "Smart Camera Supports Multiple Interfaces," Jan. 22, 2009; <http://www.optoiq.com/index/machine-vision-imaging-processing/display/vsd-article-display/350639/articles-vision-systems-design/daily-product-2/2009/01/smart-camera-supports-multiple-interfaces.html>; 2 pages.
- OptoIQ, "Vision Systems Design—Machine Vision and Image Processing Technology," [retrieved and printed on Mar. 18, 2010], <http://www.optoiq.com/index/machine-vision-imaging-processing.html>; 2 pages.
- Payatagooi, Chris, "Orchestral Manoeuvres in the Light of Telepresence," Telepresence Options, Nov. 12, 2008; [http://www.telepresenceoptions.com/2008/11/orchestral\\_manoeuvres](http://www.telepresenceoptions.com/2008/11/orchestral_manoeuvres); 2 pages.
- PCT International Preliminary Report on Patentability mailed Aug. 26, 2010 for PCT/US2009/001070; 10 pages.
- PCT International Report of Patentability dated May 15, 2006, for PCT International Application PCT/US2004/021585, 6 pages.
- PCT International Search Report mailed Aug. 24, 2010 for PCT/US2010033880; 4 pages.
- PCT Notification of Transmittal of the International Search Report and the Written Opinion of the International Searching Authority, or the Declaration for PCT/US2009/064061 mailed Feb. 23, 2010; 14 pages.
- Pixel Tools "Rate Control and H.264: H.264 rate control algorithm dynamically adjusts encoder parameters," [retrieved and printed on Jun. 10, 2010] [http://www.pixeltools.com/rate\\_control\\_paper.html](http://www.pixeltools.com/rate_control_paper.html); 7 pages.
- Radhika, N., et al., "Mobile Dynamic reconfigurable Context aware middleware for Adhoc smart spaces," vol. 22, 2008, <http://www.acadjournal.com/2008/V22/part6/p7>; 3 pages.
- Rayvel Business-to-Business Products, copyright 2004 [retrieved and printed on Feb. 24, 2009], <http://www.rayvel.com/b2b.html>; 2 pages.
- "Real-time Hand Motion/Gesture Detection for HCI-Demo 2," video clip, YouTube, posted Dec. 17, 2008 by smmy0705, 1 page; [www.youtube.com/watch?v=mLT4CFLli8A&feature=related](http://www.youtube.com/watch?v=mLT4CFLli8A&feature=related).
- Richardson, I.E.G., et al., "Fast H.264 Skip Mode Selection Using and Estimation Framework," Picture Coding Symposium, (Beijing, China), Apr. 2006; [www.rgu.ac.uk/files/richardson\\_fast\\_skip\\_estimation\\_pcs06.pdf](http://www.rgu.ac.uk/files/richardson_fast_skip_estimation_pcs06.pdf); 6 pages.
- Richardson, Iain, et al., "Video Encoder Complexity Reduction by Estimating Skip Mode Distortion," Image Communication Technology Group; [Retrieved and printed Oct. 21, 2010] 4 pages; [http://www4.rgu.ac.uk/files/ICIP04\\_richardson\\_zhao\\_final.pdf](http://www4.rgu.ac.uk/files/ICIP04_richardson_zhao_final.pdf).
- Robust Face Localisation Using Motion, Colour & Fusion; Proc. VIIth Digital Image Computing: Techniques and Applications, Sun C. et al (Eds.), Sydney; XP007905630; pp. 899-908; Dec. 10, 2003; <http://www.cmis.csiro.au/Hugues.Talbot/dicta2003/cdrom/pdf/0899.pdf>.
- Satoh, Kiyohide et al., "Passive Depth Acquisition for 3D Image Displays," IEICE Transactions on Information and Systems, Information Systems Society, Tokyo, JP, Sep. 1, 1994, vol. E77-D, No. 9, pp. 949-957.
- School of Computing, "Bluetooth over IP for Mobile Phones," 2005; [http://www.computing.dcu.ie/wwwadmin/fyp-abstract/list/fyp\\_details05.jsp?year=2005&number=51470574](http://www.computing.dcu.ie/wwwadmin/fyp-abstract/list/fyp_details05.jsp?year=2005&number=51470574); 1 page.
- Schroeder, Erica, "The Next Top Model—Collaboration," Collaboration, The Workspace: A New World of Communications and Collaboration, Mar. 9, 2009; [http://blogs.cisco.com/collaboration/comments/the\\_next\\_top\\_model](http://blogs.cisco.com/collaboration/comments/the_next_top_model); 3 pages.
- SENA, "Industrial Bluetooth," [retrieved and printed on Apr. 22, 2009] [http://www.sena.com/products/industrial\\_bluetooth](http://www.sena.com/products/industrial_bluetooth); 1 page.
- Shaffer, Shmuel, "Translation—Start of the Art" presentation; Jan. 15, 2009; 22 pages.
- Shi, C. et al., "Automatic Image Quality Improvement for Videoconferencing," IEEE ICASSP May 2004; <http://research.microsoft.com/pubs/69079/0300701.pdf>; 4 pages.
- Shum, H.-Y., et al., "A Review of Image-Based Rendering Techniques," in SPIE Proceedings vol. 4067(3): Proceedings of the Conference on Visual Communications and Image Processing 2000, Jun. 20-23, 2000, Perth, Australia; pp. 2-13; [https://research.microsoft.com/pubs/68826/review\\_image\\_rendering.pdf](https://research.microsoft.com/pubs/68826/review_image_rendering.pdf).
- "Simple Hand Gesture Recognition," video clip, YouTube, posted Aug. 25, 2008 by pooh8210, 1 page; <http://www.youtube.com/watch?v=F8GVeV0dYLM&feature=related>.
- SMARTHOME, "IR Extender Expands Your IR Capabilities," [retrieved and printed on Apr. 22, 2009], <http://www.smarthome.com/8121.html>; 3 pages.
- Soliman, H., et al., "Flow Bindings in Mobile IPv6 and NEMO Basic Support," IETF MEXT Working Group, Nov. 9, 2009, 38 pages; <http://tools.ietf.org/html/draft-ietf-mext-flow-binding-04>.
- Sonoma Wireworks Forums, "Jammin on RiffLink," [retrieved and printed on May 27, 2010] <http://www.sonomawireworks.com/forums/viewtopic.php?id=2659>; 5 pages.
- Sonoma Wireworks RiffLink, [retrieved and printed on Jun. 2, 2010] <http://www.sonomawireworks.com/rifflink.php>; 3 pages.
- Soohuan, Kim, et al., "Block-based face detection scheme using face color and motion estimation," Real-Time Imaging VIII; Jan. 20-22, 2004, San Jose, CA; vol. 5297, No. 1; Proceedings of the SPIE—The International Society for Optical Engineering SPIE—Int. Soc. Opt. Eng USA ISSN: 0277-786X; XP007905596; pp. 78-88.
- Sudan, Ranjeet, "Signaling in MPLS Networks with RSVP-TE Technology Information," Telecommunications, Nov. 2000, 3 pages; [http://findarticles.com/p/articles/mi\\_mOTLC/is\\_11\\_34/ai\\_67447072/](http://findarticles.com/p/articles/mi_mOTLC/is_11_34/ai_67447072/).
- Sullivan, Gary J., et al., "Video Compression—From Concepts to the H.264/AVC Standard," Proceedings IEEE, vol. 93, No. 1, Jan. 2005; [http://ip.hhi.de/imagecom\\_G1/assets/pdfs/piece\\_sullivan\\_wiegand\\_2005.pdf](http://ip.hhi.de/imagecom_G1/assets/pdfs/piece_sullivan_wiegand_2005.pdf); 14 pages.
- Sun, X., et al., "Region of Interest Extraction and Virtual Camera Control Based on Panoramic Video Capturing," IEEE Trans. Multimedia, Oct. 27, 2003; <http://vision.ece.ucsb.edu/publications/04mmXdsun.pdf>; 14 pages.
- Super Home Inspectors or Super Inspectors, [retrieved and printed on Mar. 18, 2010] <http://www.umrt.com/PageManager/Default.aspx/PageID=2120325>; 3 pages.
- Total Immersion, Video Gallery, copyright 2008-2009 [retrieved and printed on Feb. 26, 2009], <http://www.t-immersion.com/en,video-gallery,36.html>, 1 page.
- Trucco, E., et al., "Real-Time Disparity Maps for Immersive 3-D Teleconferencing by Hybrid Recursive Matching and Census Transform," [retrieved and printed on May 4, 2010] <http://server.cs.ucf.edu/~vision/papers/VidReg-final.pdf>; 9 pages.
- Tsapatsoulis, N., et al, "Face Detection for Multimedia Applications," Proceedings of the ICIP Sep. 10-13, 2000, Vancouver, BC, Canada; vol. 2, pp. 247-250.
- Tsapatsoulis, N., et al., "Face Detection in Color Images and Video Sequences," 10th Mediterranean Electrotechnical Conference (MELECON), May 29-31, 2000; vol. 2; pp. 498-502.
- "Vocative Case," from Wikipedia, [retrieved and printed on Mar. 3, 2011] 11 pages; [http://en.wikipedia.org/wiki/Vocative\\_case](http://en.wikipedia.org/wiki/Vocative_case).
- Wachs, J., et al., "A Real-time Hand Gesture System Based on Evolutionary Search," Vision, 3<sup>rd</sup> Quarter 2006, vol. 22, No. 3, 18 pages; <http://web.ics.purdue.edu/~jpwachs/papers/3q06vi.pdf>.
- Wang, Hualu, et al., "A Highly Efficient System for Automatic Face Region Detection in MPEG Video," IEEE Transactions on Circuits and Systems for Video Technology; vol. 7, Issue 4; 1977 pp. 615-628.
- Wang, Robert and Jovan Popovic, "Bimanual rotation and scaling," video clip, YouTube, posted by rkeltset on Apr. 14, 2010, 1 page; <http://www.youtube.com/watch?v=7TPFSCX79U>.
- Wang, Robert and Jovan Popovic, "Desktop virtual reality," video clip, YouTube, posted by rkeltset on Apr. 8, 2010, 1 page; <http://www.youtube.com/watch?v=9rBtm62Lklk>.
- Wang, Robert and Jovan Popovic, "Gestural user input," video clip, YouTube, posted by rkeltset on May 19, 2010, 1 page; <http://www.youtube.com/watch?v=3JWYTtBjdTE>.
- Wang, Robert and Jovan Popovic, "Manipulating a virtual yoke," video clip, YouTube, posted by rkeltset on Jun. 8, 2010, 1 page; <http://www.youtube.com/watch?v=UfgG002uM>.
- Wang, Robert and Jovan Popovic, "Real-Time Hand-Tracking with a Color Glove, ACM Transaction on Graphics," 4 pages, [Retrieved and printed on Dec. 1, 2010] <http://people.csall.mit.edu/rywang/hand>.

- Wang, Robert and Jovan Popovic, "Real-Time Hand-Tracking with a Color Glove, ACM Transaction on Graphics" (SIGGRAPH 2009), 28(3), Aug. 2009; 8 pages <http://people.csall.mit.edu/rywang/handtracking/s09-hand-tracking.pdf>.
- Wang, Robert and Jovan Popovic, "Tracking the 3D pose and configuration of the hand," video clip, YouTube, posted by rkelset on Mar. 31, 2010, 1 page; <http://www.youtube.com/watch?v=JOXwjKWP6Sw>.
- Westerink, P.H., et al., "Two-pass MPEG-2 variable-bitrate encoding," IBM Journal of Research and Development, Jul. 1991, vol. 43, No. 4; <http://citeseerx.ist.psu.edu/viewdoc/summary?doi=10.1.1.128.421>; 18 pages.
- Wiegand, T., et al., "Efficient mode selection for block-based motion compensated video coding," Proceedings, 2005 International Conference on Image Processing IIP 2005, pp. 2559-2562; [citeseer.ist.psu.edu/wiegand95efficient.html](http://citeseer.ist.psu.edu/wiegand95efficient.html).
- Wiegand, T., et al., "Rate-distortion optimized mode selection for very low bit rate video coding and the emerging H.263 standard," IEEE Trans. Circuits Syst. Video Technol., Apr. 1996, vol. 6, No. 2, pp. 182-190.
- Wi-Fi Protected Setup, from Wikipedia, Sep. 2, 2010, 3 pages [http://en.wikipedia.org/wiki/Wi-Fi\\_Protected\\_Setup](http://en.wikipedia.org/wiki/Wi-Fi_Protected_Setup).
- Wilson, Mark, "Dreamoc 3D Display Turns Any Phone Into Hologram Machine," Oct. 30, 2008; <http://gizmodo.com/5070906/dreamoc-3d-display-turns-any-phone-into-hologram-machine>; 2 pages.
- WirelessDevNet, Melody Launches Bluetooth Over IP, [retrieved and printed on Jun. 5, 2010] <http://www.wirelessdevnet.com/news/2001/155/news5.html>; 2 pages.
- Xia, F., et al., "Home Agent Initiated Flow Binding for Mobile IPv6," Network Working Group, Oct. 19, 2009, 15 pages; <http://tools.ietf.org/html/draft-xia-mext-ha-init-flow-binding-01.txt>.
- Xin, Jun, et al., "Efficient macroblock coding-mode decision for H.264/AVC video coding," Technical Report MERL 2004-079, Mitsubishi Electric Research Laboratories, Jan. 2004; [www.merl.com/publications/TR2004-079/](http://www.merl.com/publications/TR2004-079/); 12 pages.
- Yang, Jie, et al., "A Real-Time Face Tracker," Proceedings 3rd IEEE Workshop on Applications of Computer Vision; 1996; Dec. 2-4, 1996; pp. 142-147; [http://www.ri.cmu.edu/pub\\_files/pub1/yang\\_jie\\_1996\\_1/yang\\_jie\\_1996\\_1.pdf](http://www.ri.cmu.edu/pub_files/pub1/yang_jie_1996_1/yang_jie_1996_1.pdf).
- Yang, Ming-Hsuan, et al., "Detecting Faces in Images: A Survey," vol. 24, No. 1; Jan. 2002; pp. 34-58; <http://vision.ai.uiuc.edu/mhyang/papers/pami02a.pdf>.
- Yang, Ruigang, et al., "Real-Time Consensus-Based Scene Reconstruction using Commodity Graphics Hardware," Department of Computer Science, University of North Carolina at Chapel Hill; 2002; [http://www.cs.unc.edu/Research/stc/publications/yang\\_pacigra2002.pdf](http://www.cs.unc.edu/Research/stc/publications/yang_pacigra2002.pdf); 10 pages.
- Yang, Xiaokang, et al., Rate Control for H.264 with Two-Step Quantization Parameter Determination but Single-Pass Encoding, EURASIP Journal on Applied Signal Processing, Jun. 2006; <http://downloads.hindawi.com/journals/asp/2006/063409.pdf>; 13 pages.
- Yegani, P. et al., "GRE Key Extension for Mobile IPv4," Network Working Group, Feb. 2006; 11 pages; <http://tools.ietf.org/pdf/draft-yegani-gre-key-extension-01.pdf>.
- Yoo, Byounghun, et al., "Image-Based Modeling of Urban Buildings Using Aerial Photographs and Digital Maps," Transactions in GIS, 2006, 10(3): p. 377-394.
- Zhong, Ren, et al., "Integration of Mobile IP and MPLS," Network Working Group, Jul. 2000, 15 pages; <http://tools.ietf.org/html/draft-zhong-mobile-ip-mpls-01>.
- "Oblong Industries is the developer of the g-speak spatial operation environment," Oblong Industries Information Page, 2 pages, [Retrieved and printed on Dec. 1, 2010] <http://oblong.com>.
- Underkoffler, John, "G-Speak Overview 1828121108," video clip, Vimeo.com, 1 page, [Retrieved and printed on Dec. 1, 2010] <http://vimeo.com/2229299>.
- Kramer, Kwindla, "Mary Ann de Lares Norris at Thinking Digital," Oblong Industries, Inc. Web Log, Aug. 24, 2010; 1 page; <http://oblong.com/articles/0BS6hEelmoHoCwgJ.html>.
- "Mary Ann de Lares Norris," video clip, Thinking Digital 2010 Day Two, Thinking Digital Videos, May 27, 2010, 3 pages; <http://videos.thinkingdigital.co.uk/2010/05/mary-ann-de-lares-norris-oblong/>.
- Kramer, Kwindla, "Oblong at TED," Oblong Industries, Inc. Web Log, Jun. 6, 2010, 1 page; <http://oblong.com/article/OB22LFIS1NVyrOmR.html>.
- "John Underkoffler points to the future of UI," video clip and interactive transcript, Video on TED.com, Jun. 2010, 6 pages; [http://www.ted.com/talks/john\\_underkoffler\\_drive\\_3d\\_data\\_with\\_a\\_gesture.html](http://www.ted.com/talks/john_underkoffler_drive_3d_data_with_a_gesture.html).
- Kramer, Kwindla, "Oblong on Bloomberg TV," Oblong Industries, Inc. Web Log, Jan. 28, 2010, 1 page; [http://oblong.com/article/0AN\\_1KD9q990PENw.html](http://oblong.com/article/0AN_1KD9q990PENw.html).
- Kramer, Kwindla, "g-speak at RISD, Fall 2009," Oblong Industries, Inc. Web Log, Oct. 29, 2009, 1 page; <http://oblong.com/article/09uW060q6xRIZYvm.html>.
- Kramer, Kwindla, "g-speak + TMG," Oblong Industries, Inc. Web Log, Mar. 24, 2009, 1 page; <http://oblong.com/article/08mM77zpYMm7kFtv.html>.
- "G-stalt version 1," video clip, YouTube.com, posted by ziggles on Mar. 15, 2009, 1 page; <http://youtube.com/watch?v=k8ZAq14mdvk>.
- Underkoffler, John, "Carlton Sparrell speaks at MIT," Oblong Industries, Inc. Web Log, Oct. 30, 2009, 1 page; <http://oblong.com/article/09usAB411Ukb6CPw.html>.
- Underkoffler, John, "Carlton Sparrell at MIT Media Lab," video clip, Vimeo.com, 1 page, [Retrieved and printed Dec. 1, 2010] <http://vimeo.com/7355992>.
- Underkoffler, John, "Oblong at Altitude: Sundance 2009," Oblong Industries, Inc. Web Log, Jan. 20, 2009, 1 page; [http://oblong.com/article/08Sr62ron\\_2akg0D.html](http://oblong.com/article/08Sr62ron_2akg0D.html).
- Underkoffler, John, "Oblong's tamper system 1801011309," video clip, Vimeo.com, 1 page, [Retrieved and printed Dec. 1, 2010] <http://vimeo.com/2821182>.
- Feld, Brad, "Science Fact," Oblong Industries, Inc. Web Log, Nov. 13, 2008, 2 pages; <http://oblong.com/article/084H-PKISTb914T1.html>.
- Kwindla Kramer, "g-speak in slices," Oblong Industries, Inc. Web Log, Nov. 13, 2008, 6 pages; <http://oblong.com/article/0866JqfNrFg1NeuK.html>.
- Underkoffler, John, "Origins: arriving here," Oblong Industries, Inc. Web Log, Nov. 13, 2008, 5 pages; <http://oblong.com/article/085zBpRSY9JeLv2z.html>.
- Rishel, Christian, "Commercial overview: Platform and Products," Oblong Industries, Inc., Nov. 13, 2008, 3 pages; <http://oblong.com/article/086E19gPvDcktAf9.html>.
- Andreopoulos, Yiannis, et al., "In-Band Motion Compensated Temporal Filtering," Signal Processing: Image Communication 19 (2004) 653-673, 21 pages <http://medianetlab.ee.ucla.edu/papers/011.pdf>.
- Arulampalam, M. Sanjeev, et al., "A Tutorial on Particle Filters for Online Nonlinear/Non-Gaussian Bayesian Tracking," IEEE Transactions on Signal Processing, vol. 50, No. 2, Feb. 2002, 15 pages <http://www.cs.ubc.ca/~murphyk/Software/Kalman/ParticleFilterTutorial.pdf>.
- "Garg, Ashutosh, et al.," "Audio-Visual ISpeaker Detection Using Dynamic Bayesian Networks," "IEEE International Conference on Automatic Face and Gesture Recognition, 2000 Proceedings, 7 pages <http://www.ifp.illinois.edu/~ashutosh/papers/FG00.pdf>".
- Lambert, "Polycom Video Communications," © 2004 Polycom, Inc., Jun. 20, 2004 [http://www.polycom.com/global/documents/whitepapers/video\\_communications\\_h.239\\_people\\_content\\_polycom\\_patented\\_technology.pdf](http://www.polycom.com/global/documents/whitepapers/video_communications_h.239_people_content_polycom_patented_technology.pdf).

\* cited by examiner



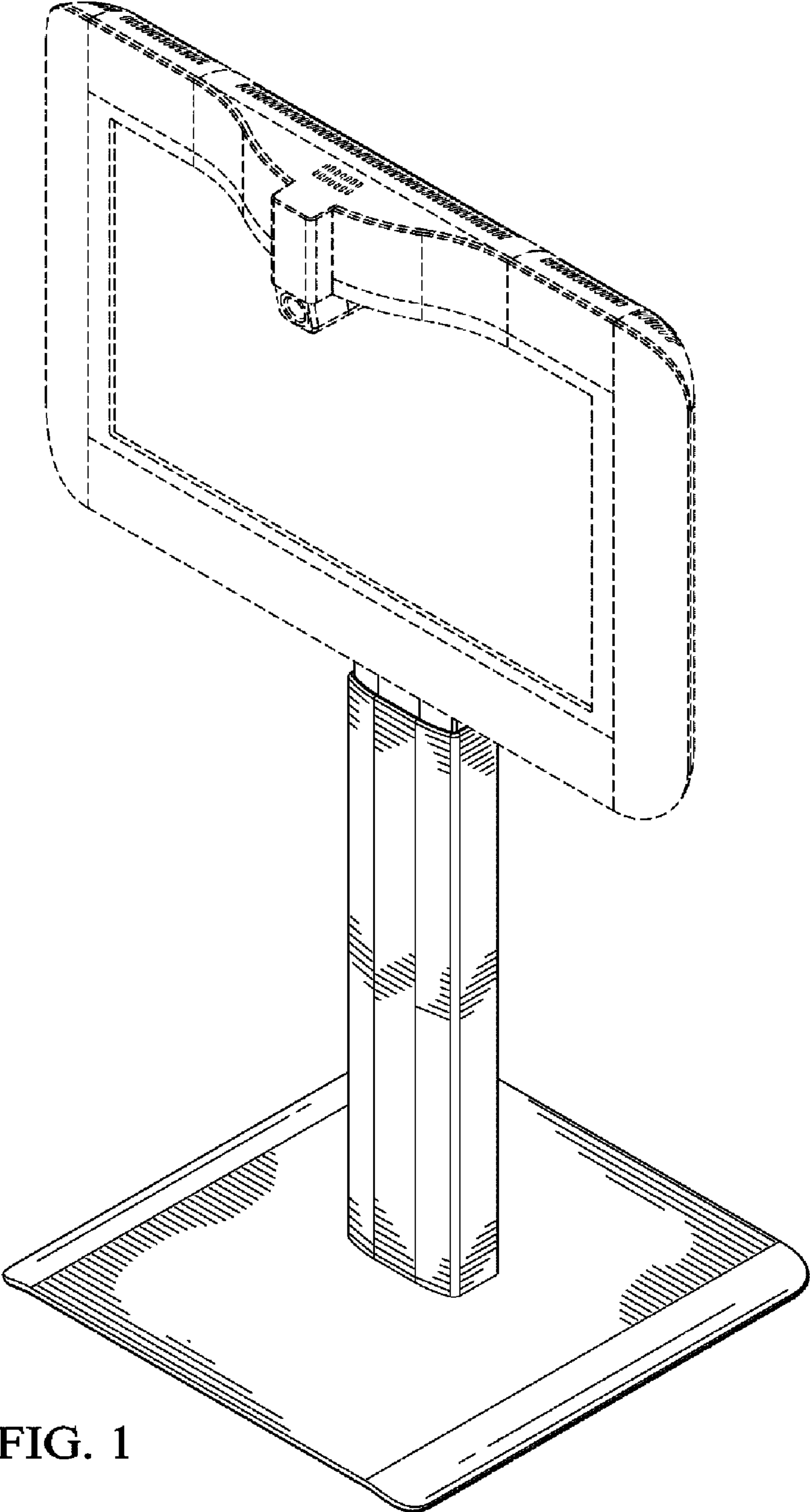

FIG. 1

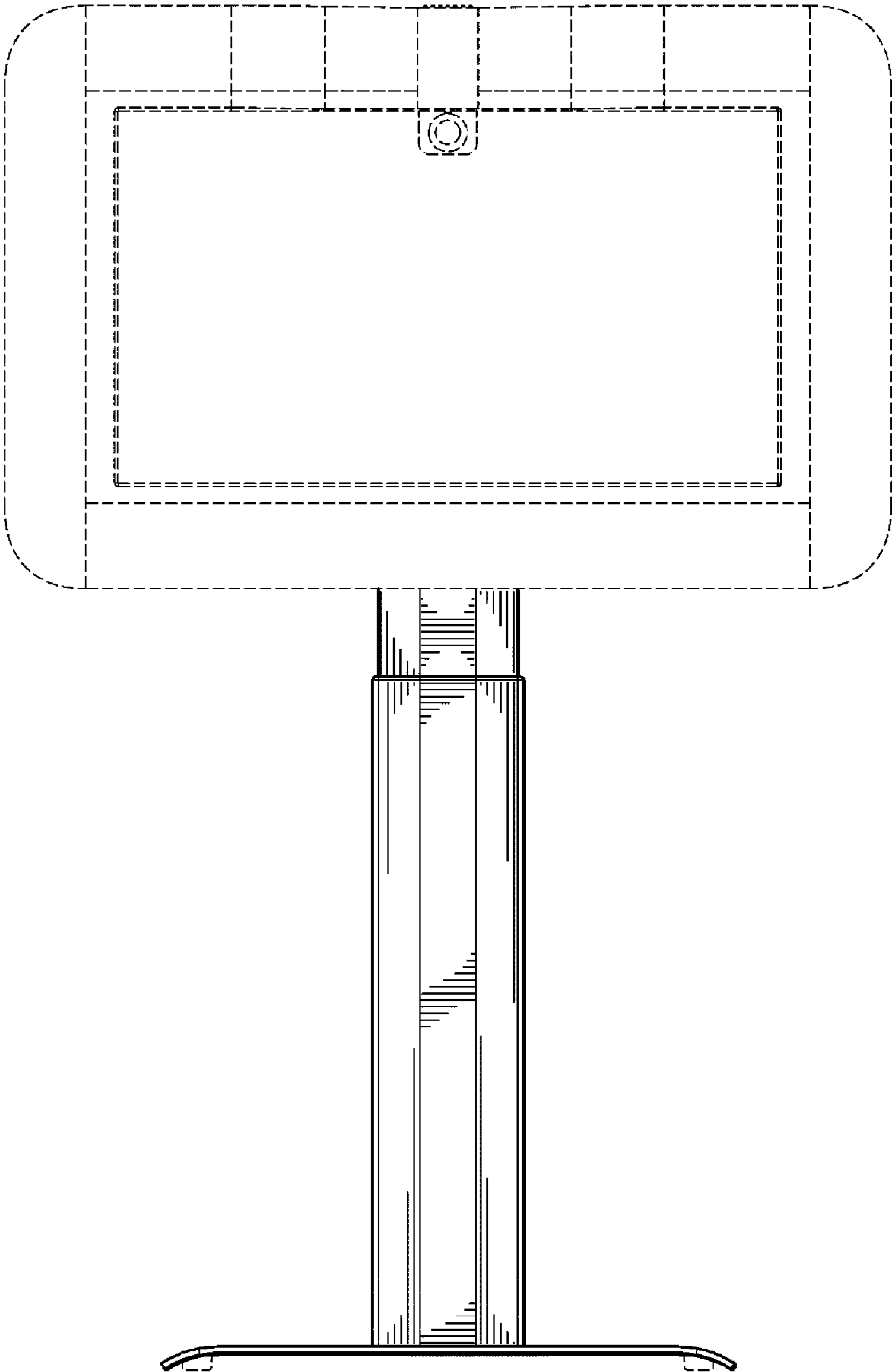

FIG. 2

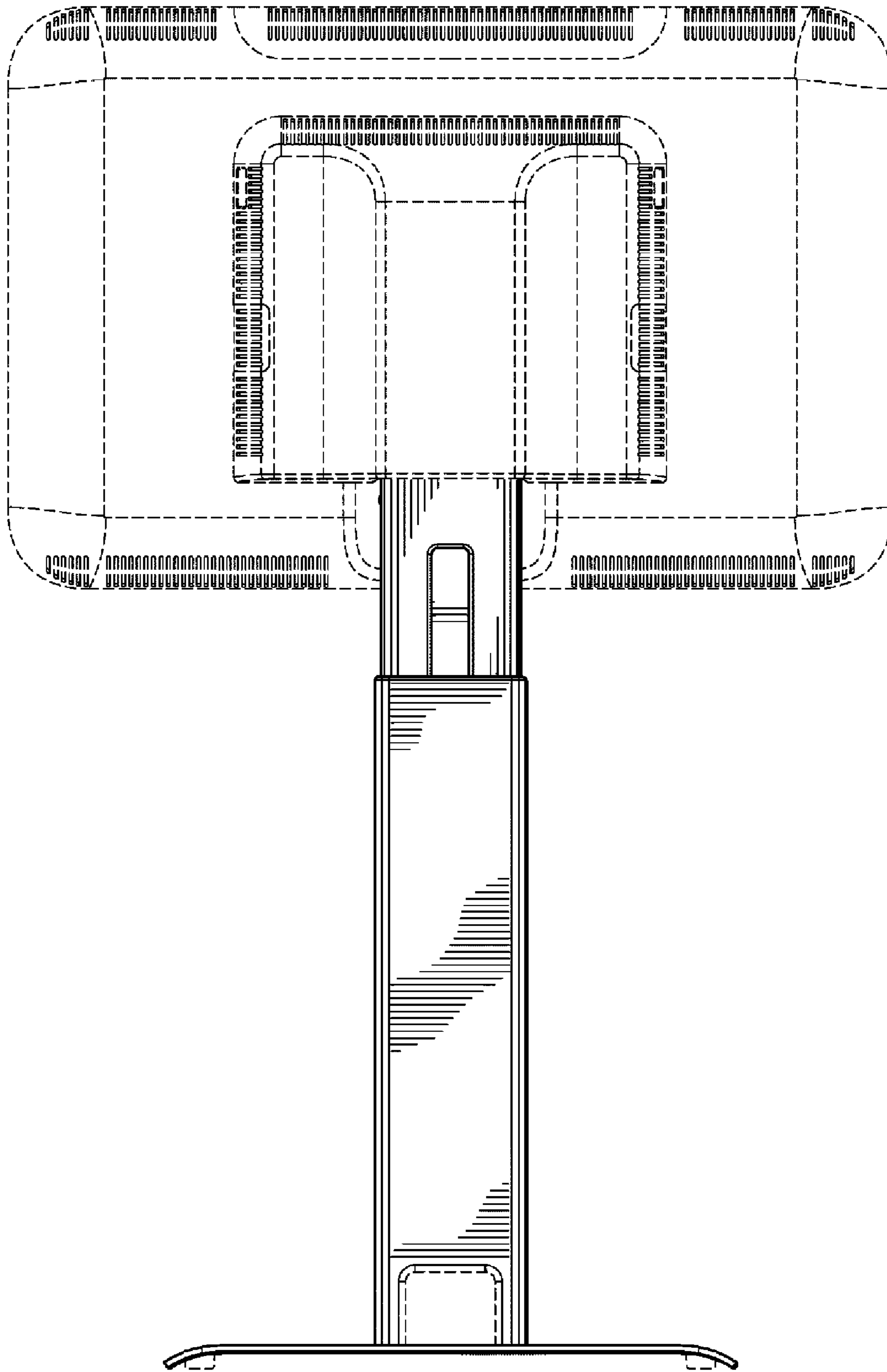

FIG. 3

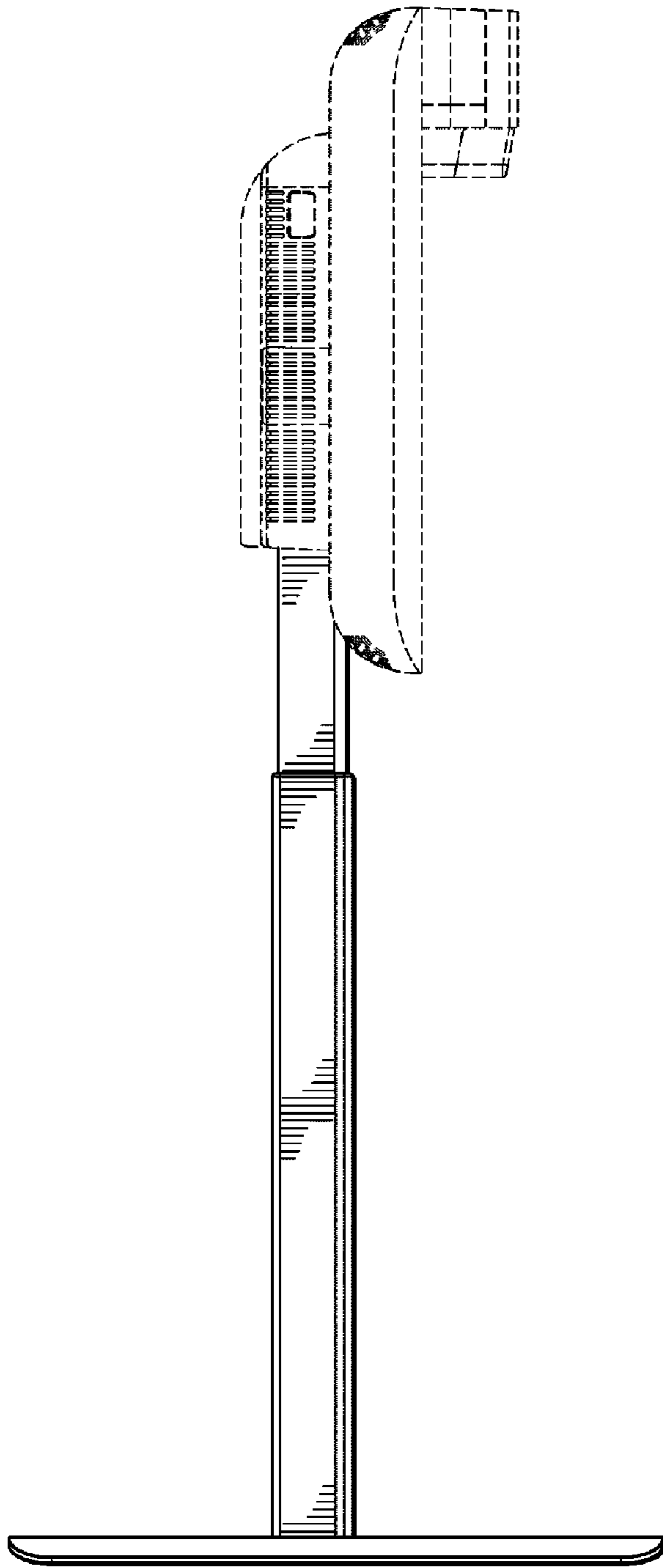

FIG. 4

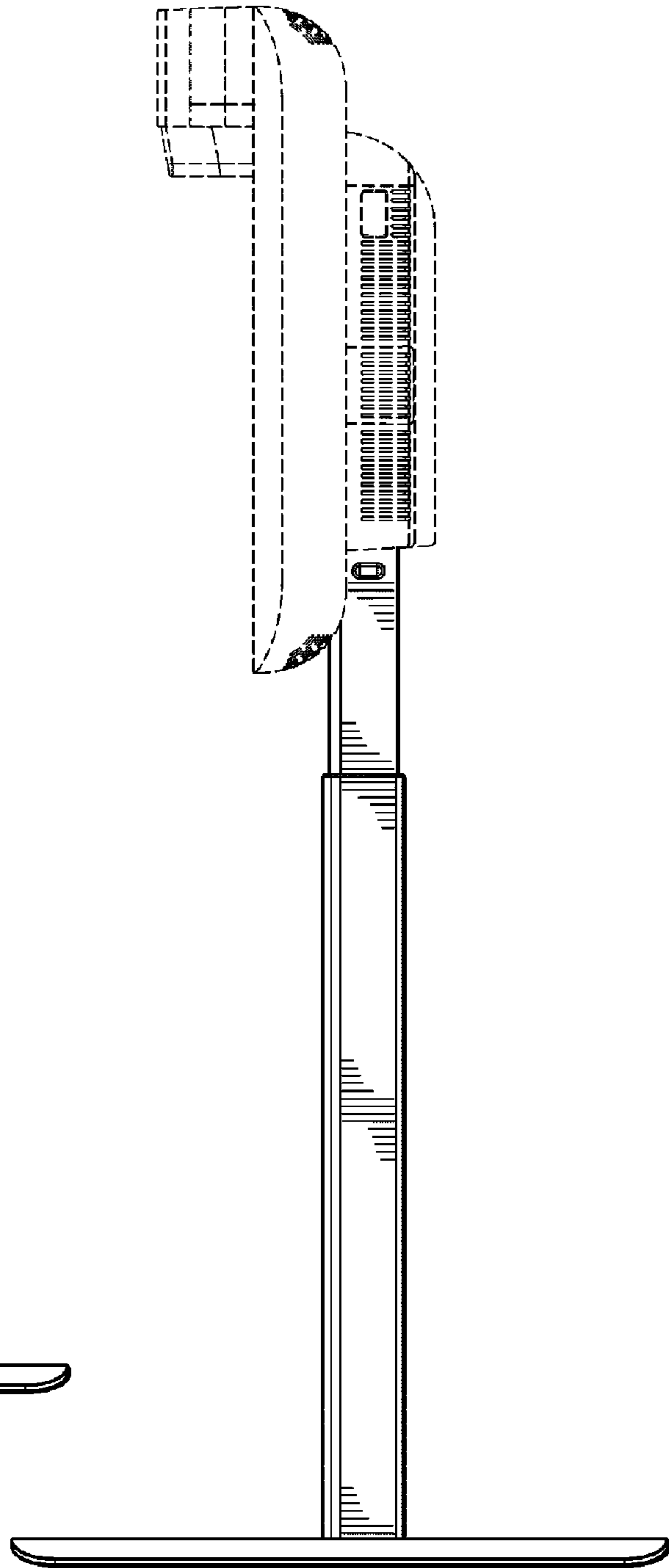

FIG. 5

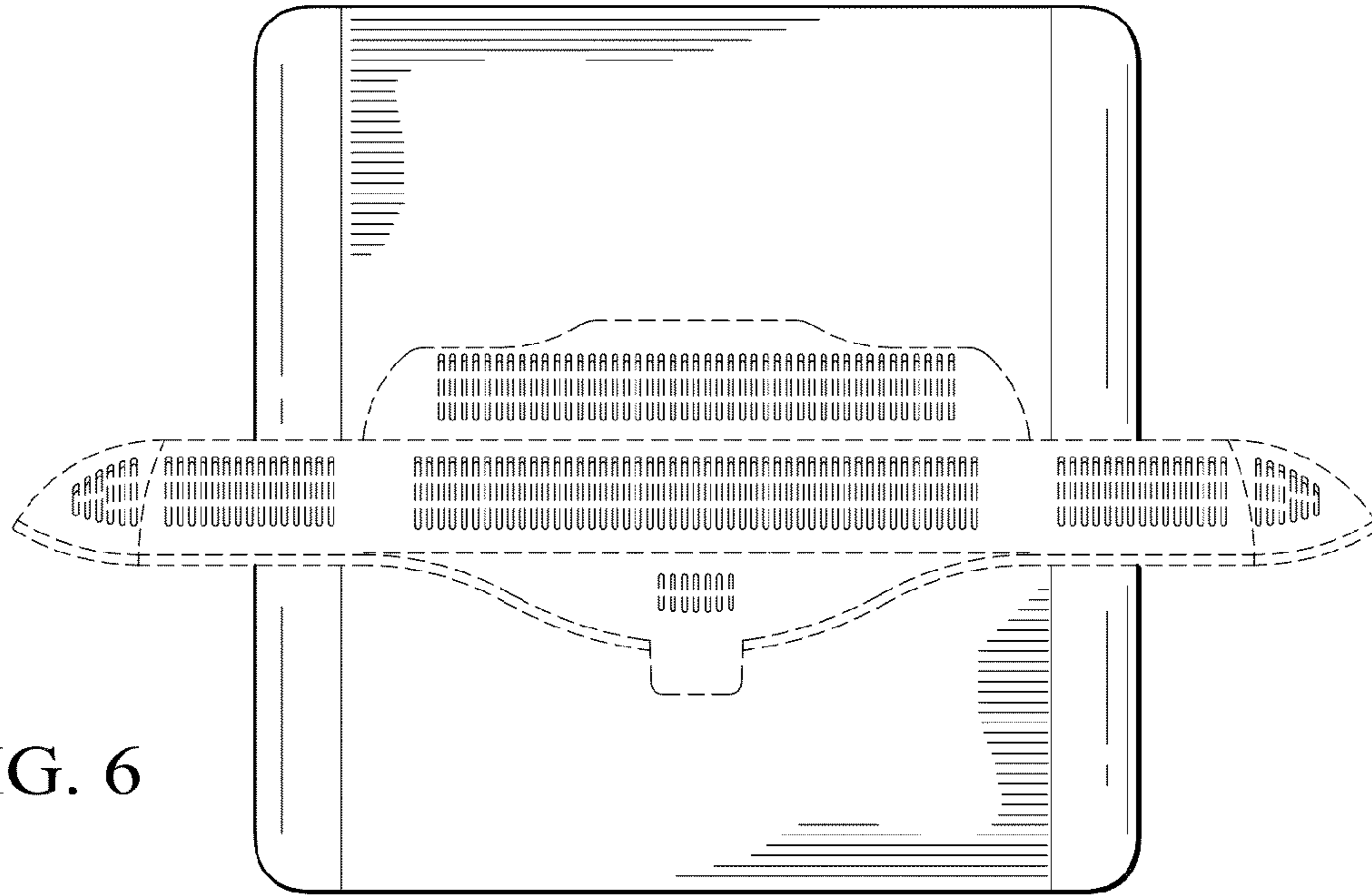

FIG. 6

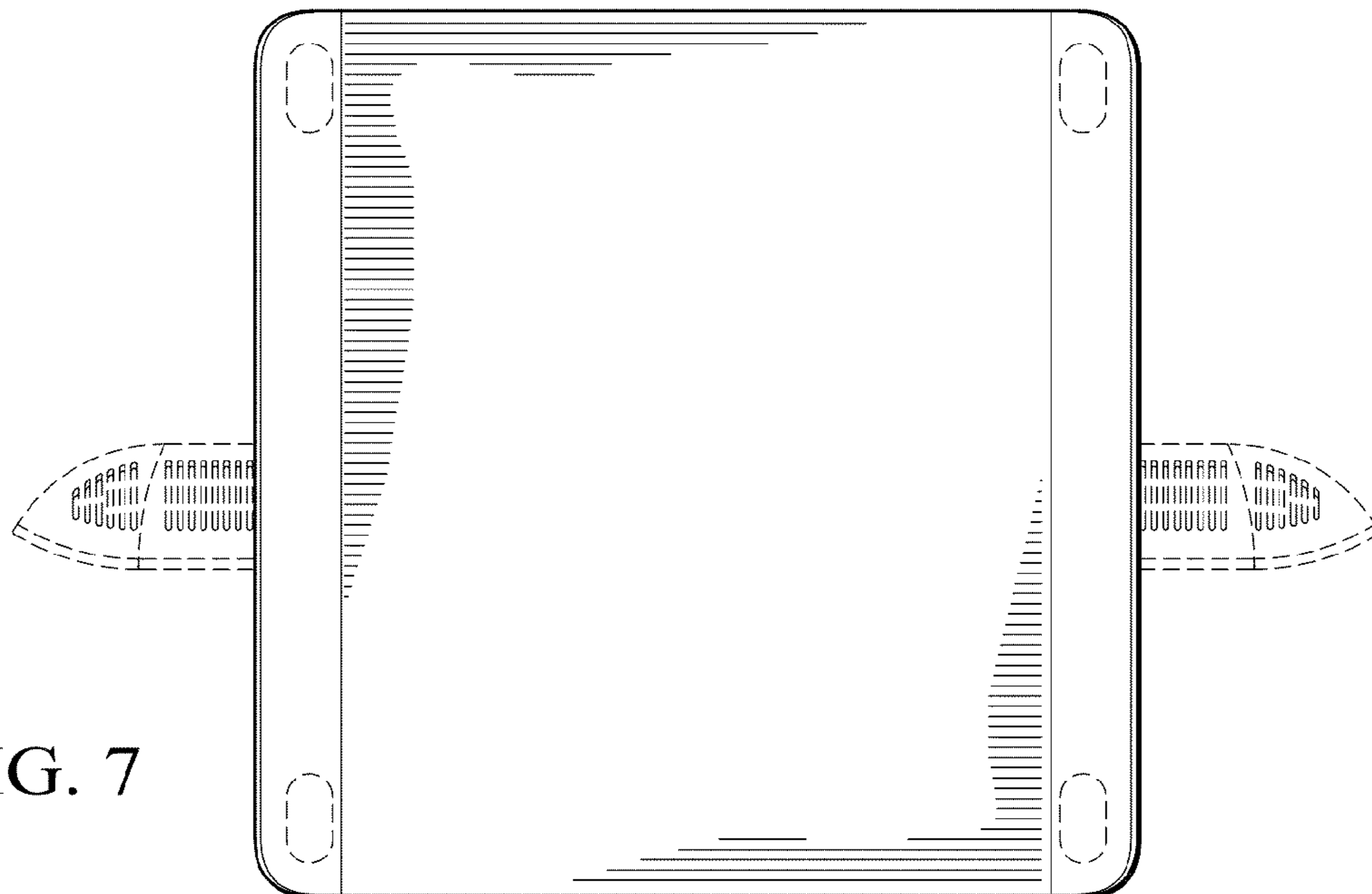

FIG. 7

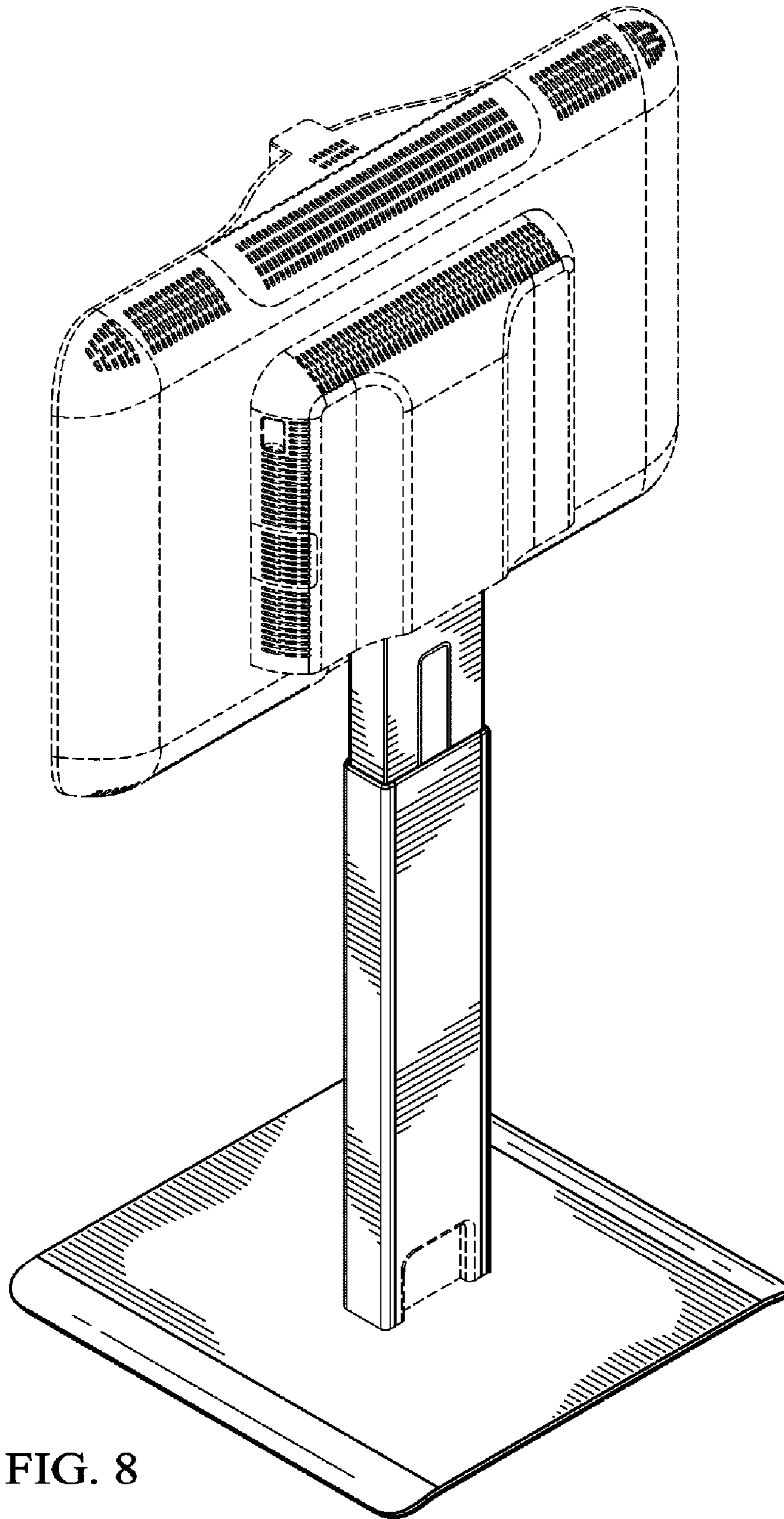

FIG. 8