



US00D653242S

(12) **United States Design Patent**  
**Katsuraku et al.**

(10) **Patent No.:** **US D653,242 S**  
(45) **Date of Patent:** **\*\* Jan. 31, 2012**

(54) **EARPHONE**

(75) Inventors: **Junko Katsuraku**, Tokyo (JP); **Hiromi Inukai**, Tokyo (JP)

(73) Assignee: **Sony Corporation**, Tokyo (JP)

(\*\*) Term: **14 Years**

(21) Appl. No.: **29/371,016**

(22) Filed: **Sep. 14, 2010**

(30) **Foreign Application Priority Data**

Mar. 17, 2010 (JP) ..... D2010-006540  
Mar. 17, 2010 (JP) ..... D2010-006541  
Mar. 17, 2010 (JP) ..... D2010-006542

(51) **LOC (9) Cl.** ..... **14-01**

(52) **U.S. Cl.** ..... **D14/223**

(58) **Field of Classification Search** ..... D14/205,  
D14/206, 223, 147, 248, 249; 181/129, 130,  
181/135; 379/430, 431; D24/174; 128/865,  
128/866; 381/380, 381, 322, 328; 455/90.3,  
455/575.1

See application file for complete search history.

(56) **References Cited**

**U.S. PATENT DOCUMENTS**

D267,429 S *	12/1982	Harada	.....	D24/174
D396,473 S *	7/1998	Brito	.....	D14/249
D396,725 S *	8/1998	Brito	.....	D14/249
7,082,206 B2 *	7/2006	Mahoney et al.	.....	381/328
D550,657 S *	9/2007	Gan et al.	.....	D14/223
D564,495 S *	3/2008	Sasaki	.....	D14/205
D567,217 S *	4/2008	Kamo et al.	.....	D14/205
D572,703 S *	7/2008	Ledbetter et al.	.....	D14/205
D573,978 S *	7/2008	Ledbetter et al.	.....	D14/205
D587,681 S *	3/2009	Yanai	.....	D14/205
D589,151 S *	3/2009	Sabio	.....	D24/174
D589,493 S *	3/2009	Densho	.....	D14/206
D591,721 S *	5/2009	Densho	.....	D14/205
D602,905 S *	10/2009	Morisawa	.....	D14/205
D606,971 S *	12/2009	Christopher et al.	.....	D14/205
D618,670 S *	6/2010	Tahara	.....	D14/223
D623,630 S *	9/2010	Ohori et al.	.....	D14/223
D633,086 S *	2/2011	Chen	.....	D14/223

**OTHER PUBLICATIONS**

Web page, "Space Violet Headphones & Space Jet Hematite Headphones", <http://journal.mycom.co.jp/news/2008/03/04/024/index.html>, 1 sheet, Minichi Communication Inc., 2010.

Web page, "Skullcandy FMJ Gold", <http://jp.skullcandy.com/shop/fmj-gold.htm>, 1 sheet, Skullcandy, 2010.

\* cited by examiner

*Primary Examiner* — Paula Greene

(74) *Attorney, Agent, or Firm* — Rader, Fishman & Grauer PLLC

(57) **CLAIM**

The ornamental design for an earphone, as shown and described.

**DESCRIPTION**

FIG. 1 is a perspective view of an earphone showing our new design;  
FIG. 2 is a front elevational view thereof;  
FIG. 3 is a rear elevational view thereof;  
FIG. 4 is a top plan view thereof;  
FIG. 5 is a bottom plan view thereof;  
FIG. 6 is a right side elevational view thereof; and  
FIG. 7 is a left side elevational view thereof.  
FIG. 8 is a perspective view of another embodiment of an earphone showing our new design;  
FIG. 9 is a front elevational view thereof;  
FIG. 10 is a rear elevational view thereof;  
FIG. 11 is a top plan view thereof;  
FIG. 12 is a bottom plan view thereof;  
FIG. 13 is a right side elevational view thereof; and  
FIG. 14 is a left side elevational view thereof.  
FIG. 15 is a perspective view of still another embodiment of an earphone showing our new design;  
FIG. 16 is a front elevational view thereof;  
FIG. 17 is a rear elevational view thereof;  
FIG. 18 is a top plan view thereof;  
FIG. 19 is a bottom plan view thereof;  
FIG. 20 is a right side elevational view thereof; and,  
FIG. 21 is a left side elevational view thereof.  
The portions in broken lines are for illustrative purpose only and form no part of the claimed design. The dot-dash lines define, but are not included in, the boundaries of the claimed design.

**1 Claim, 21 Drawing Sheets**

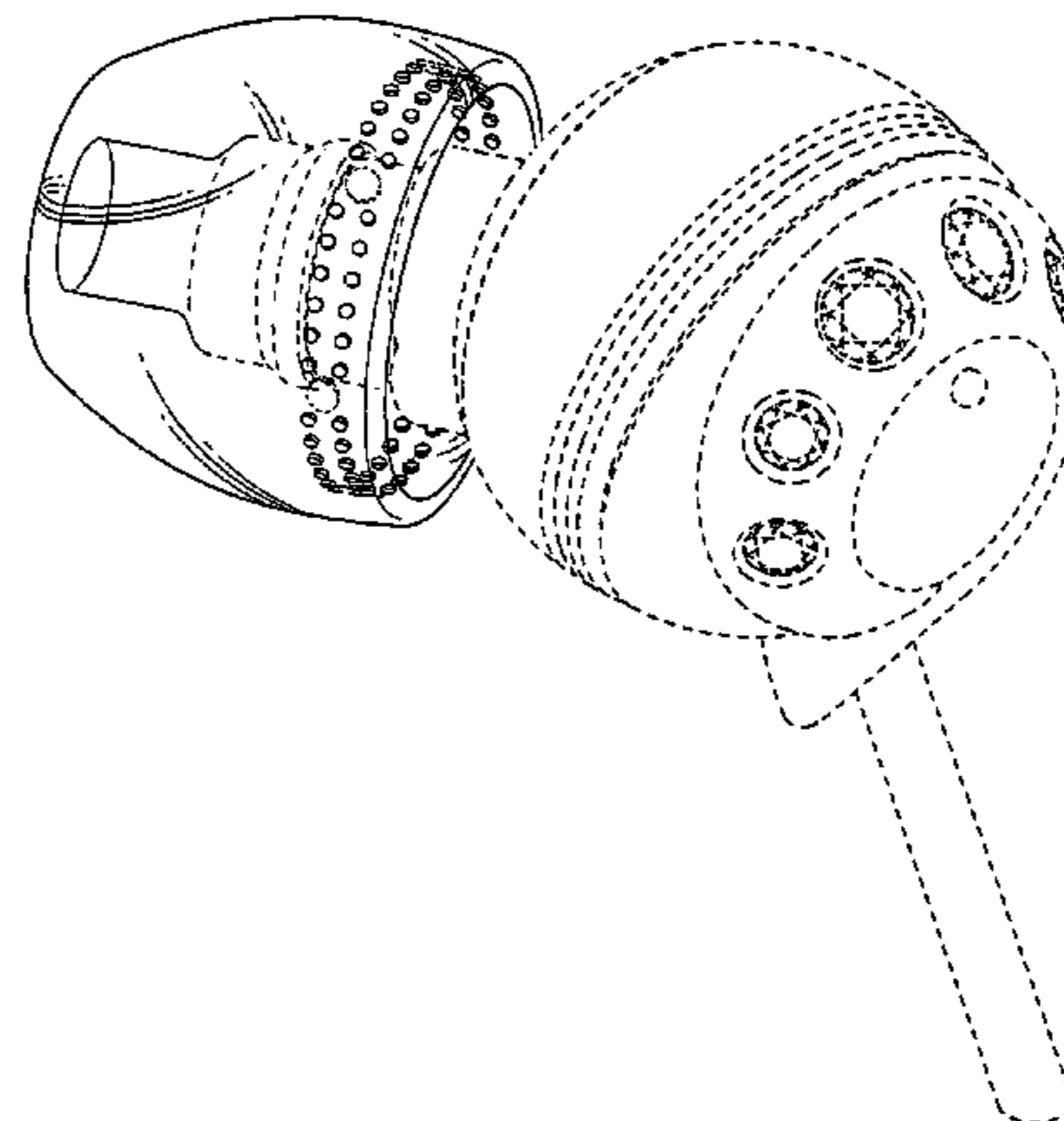
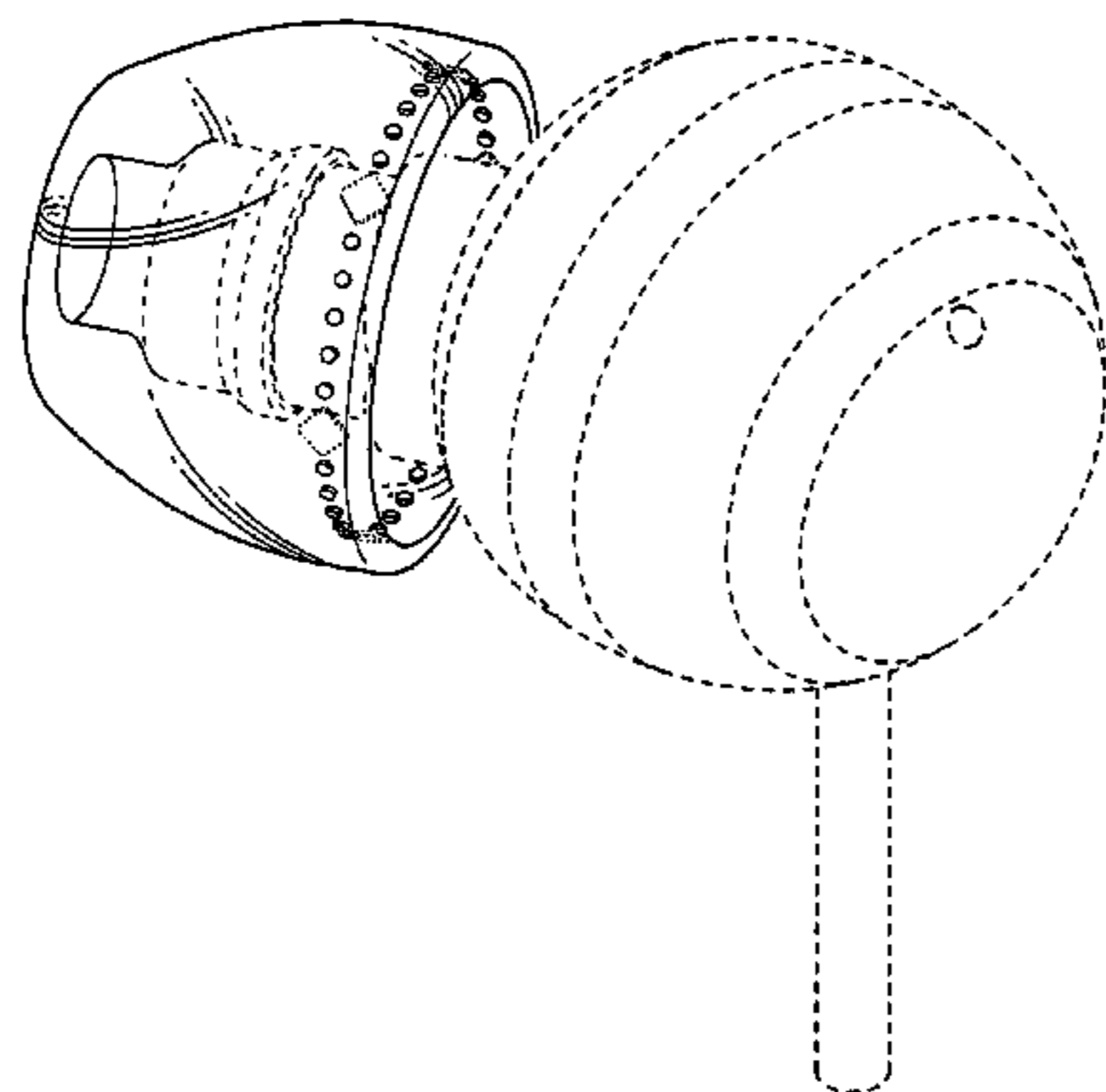

FIG.1

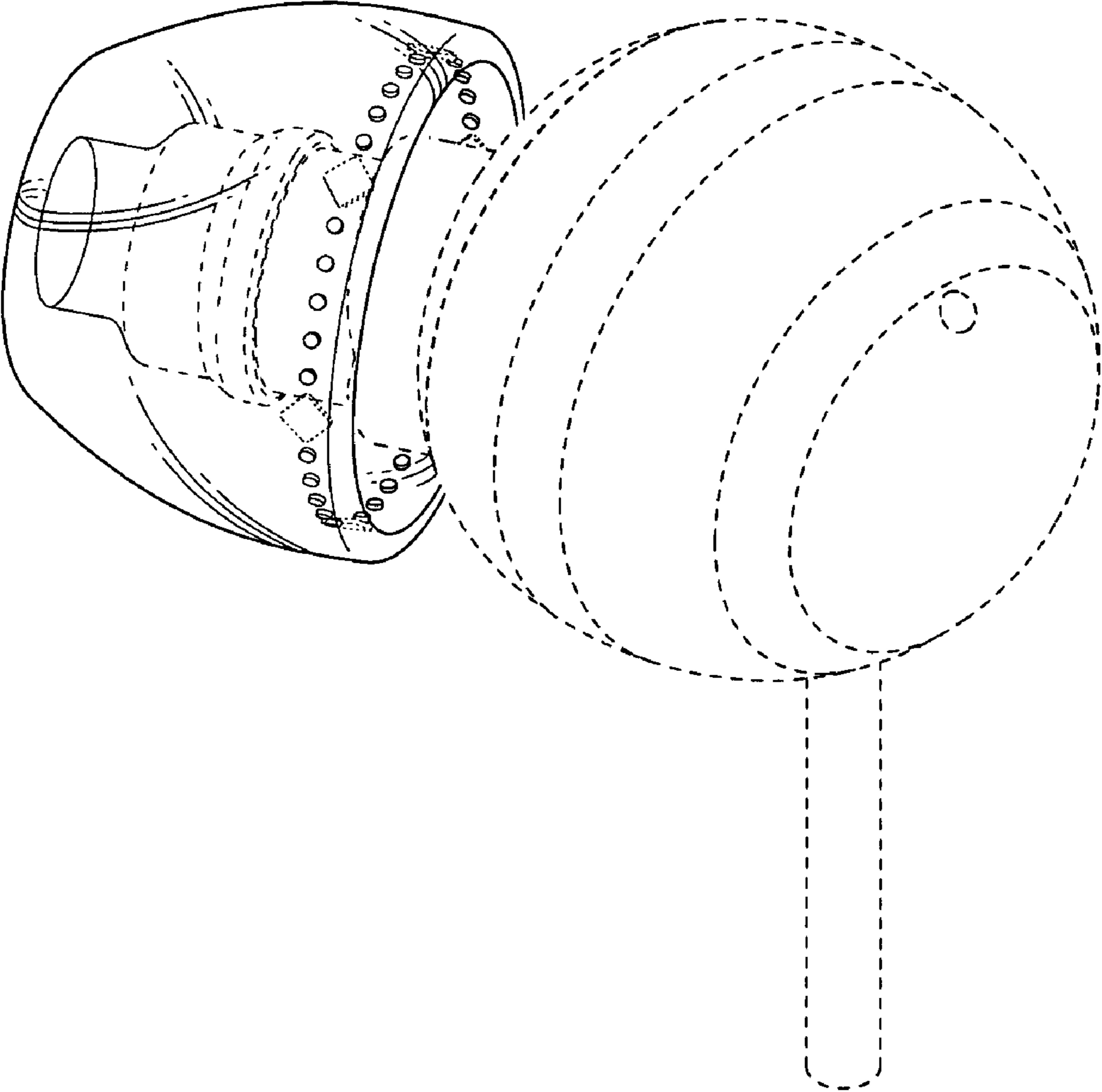

FIG.2

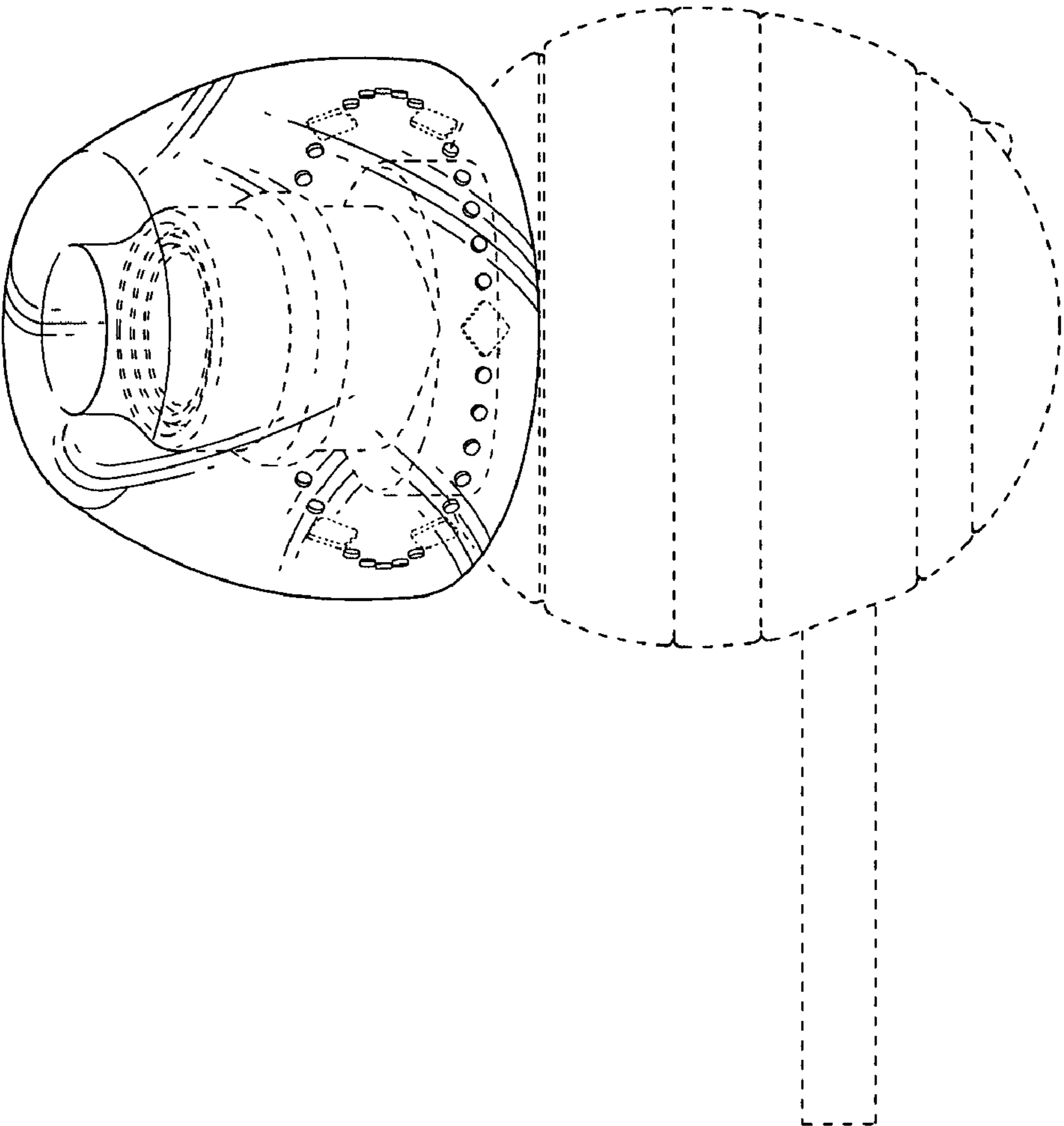

FIG.3

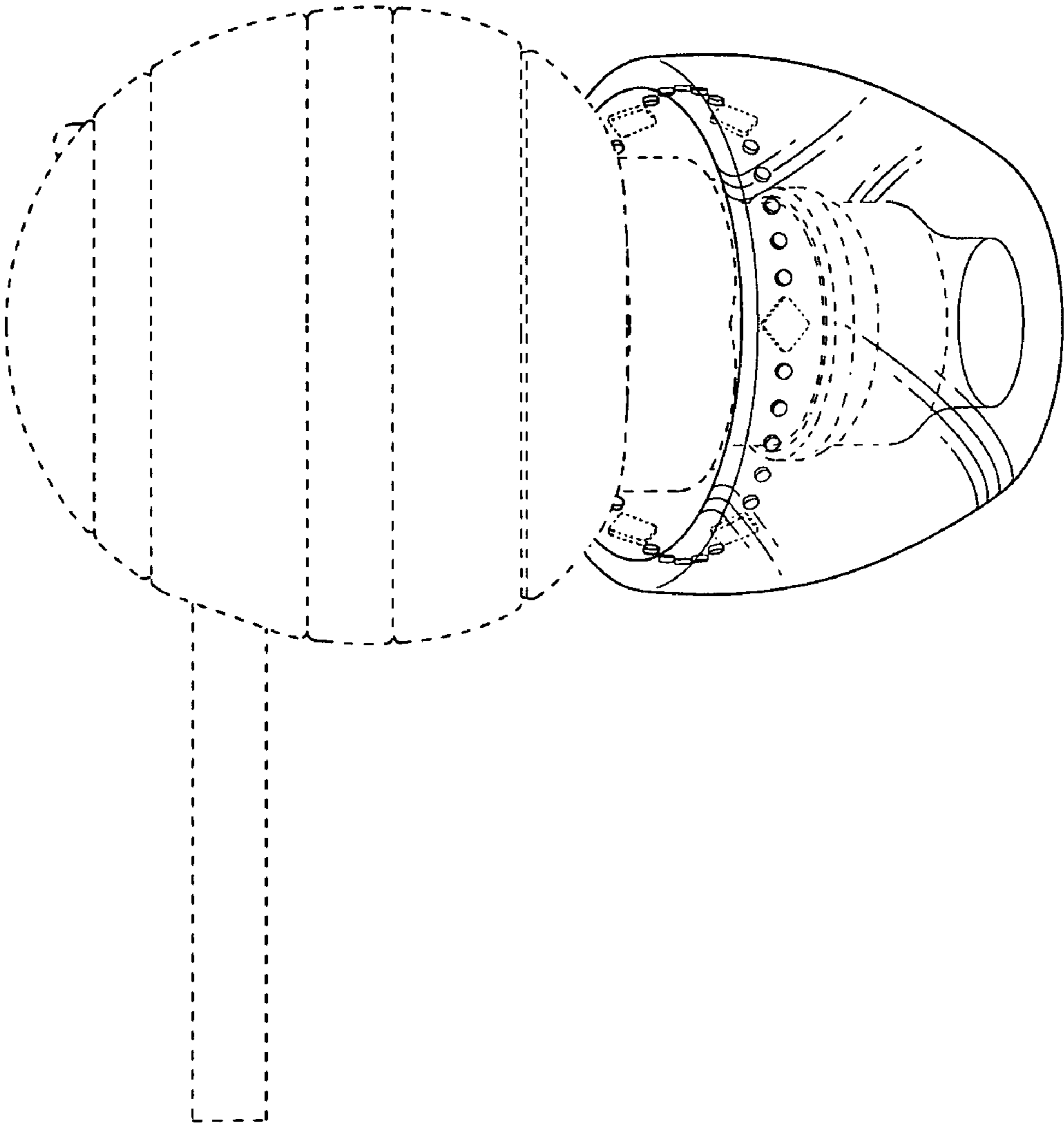

FIG.4

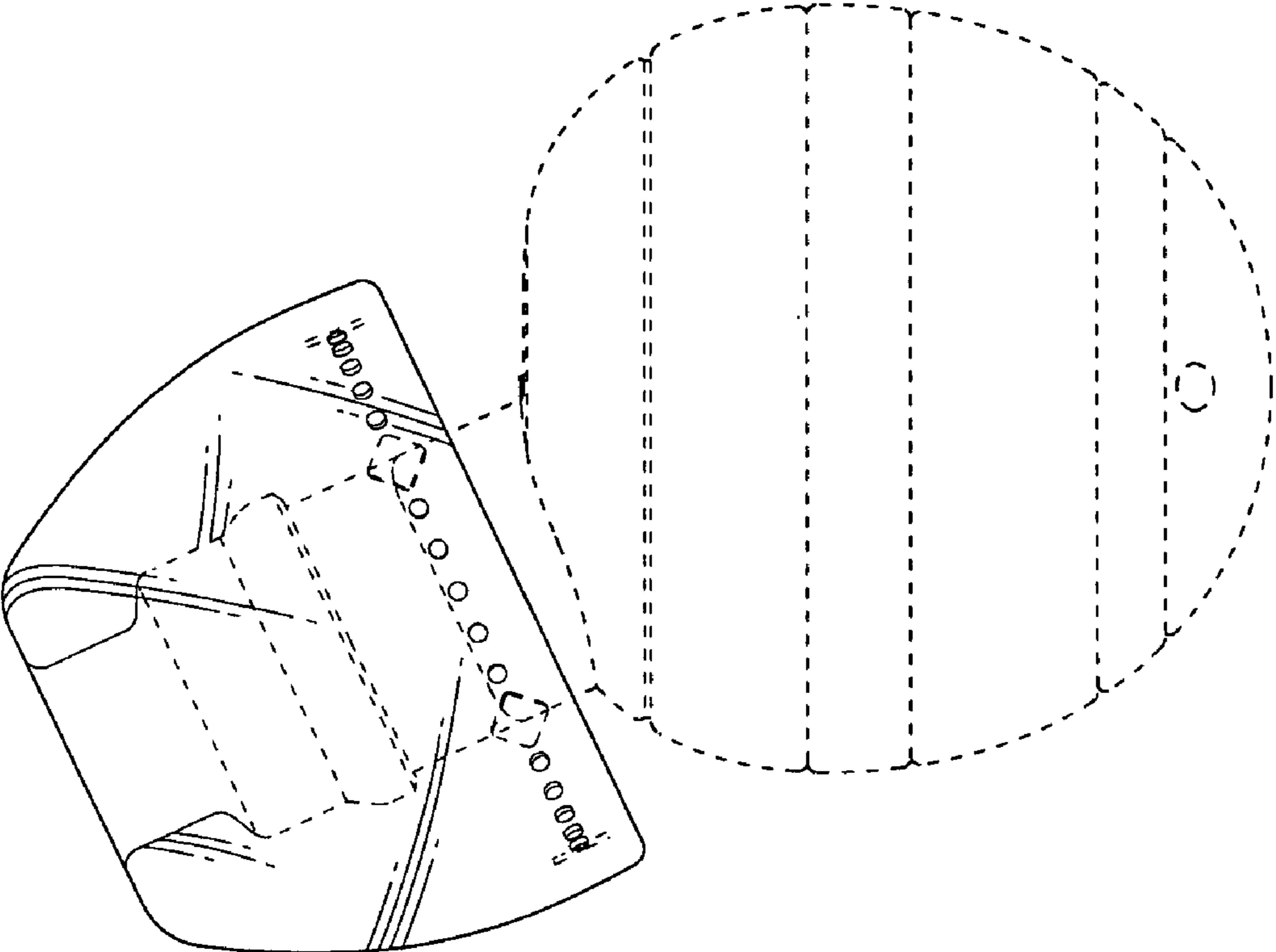

FIG.5

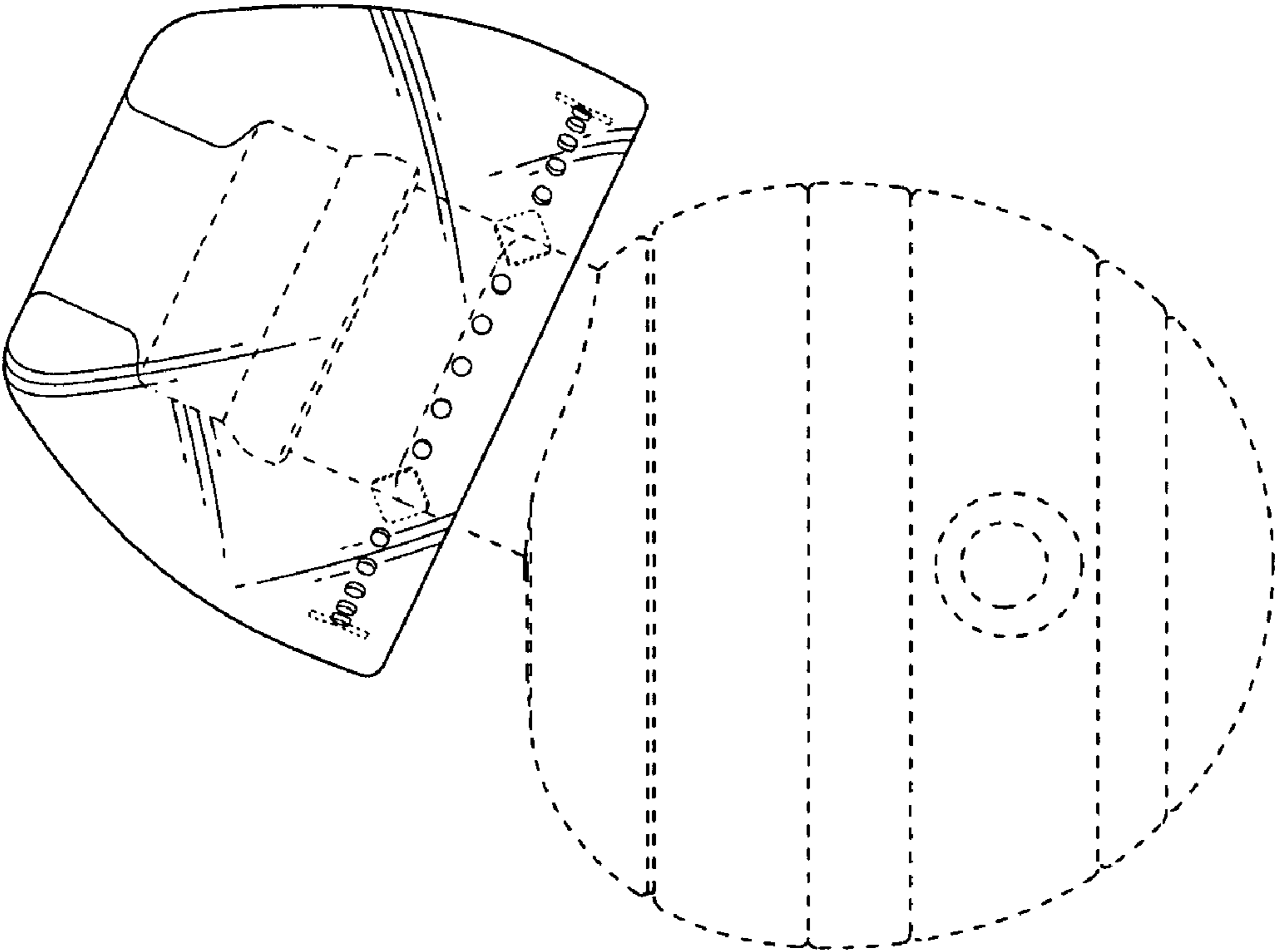

FIG.6

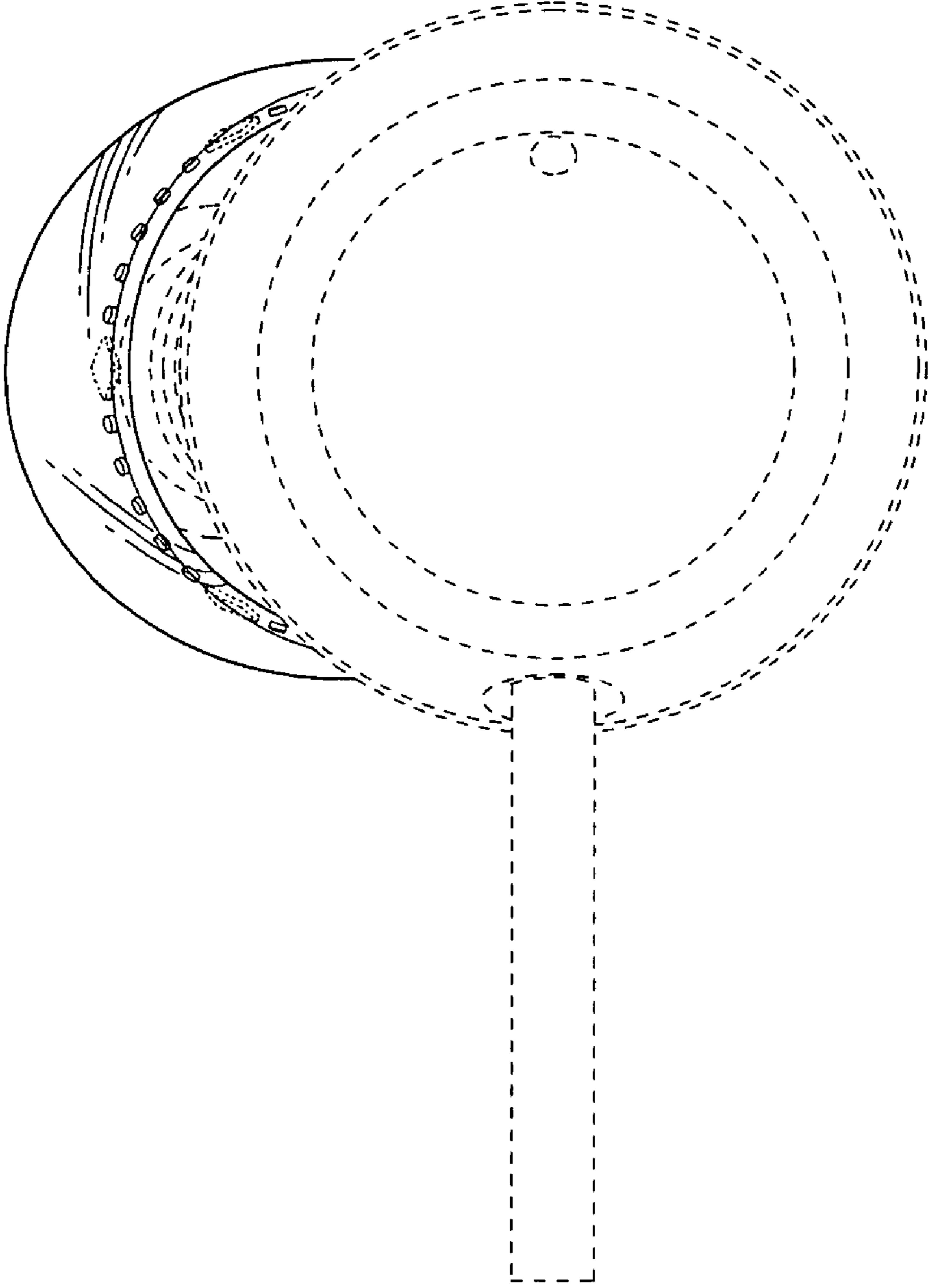

FIG.7

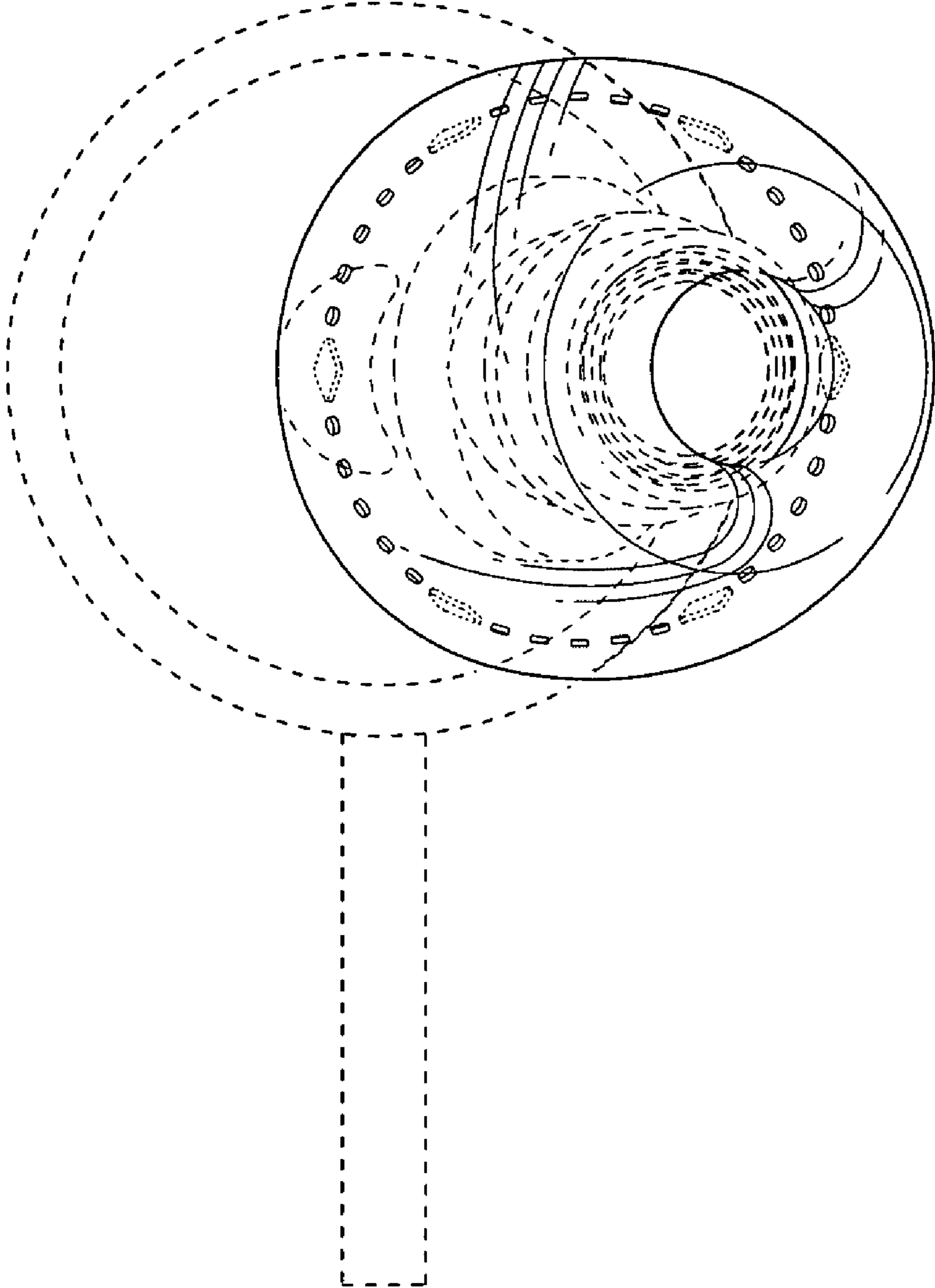



FIG.8

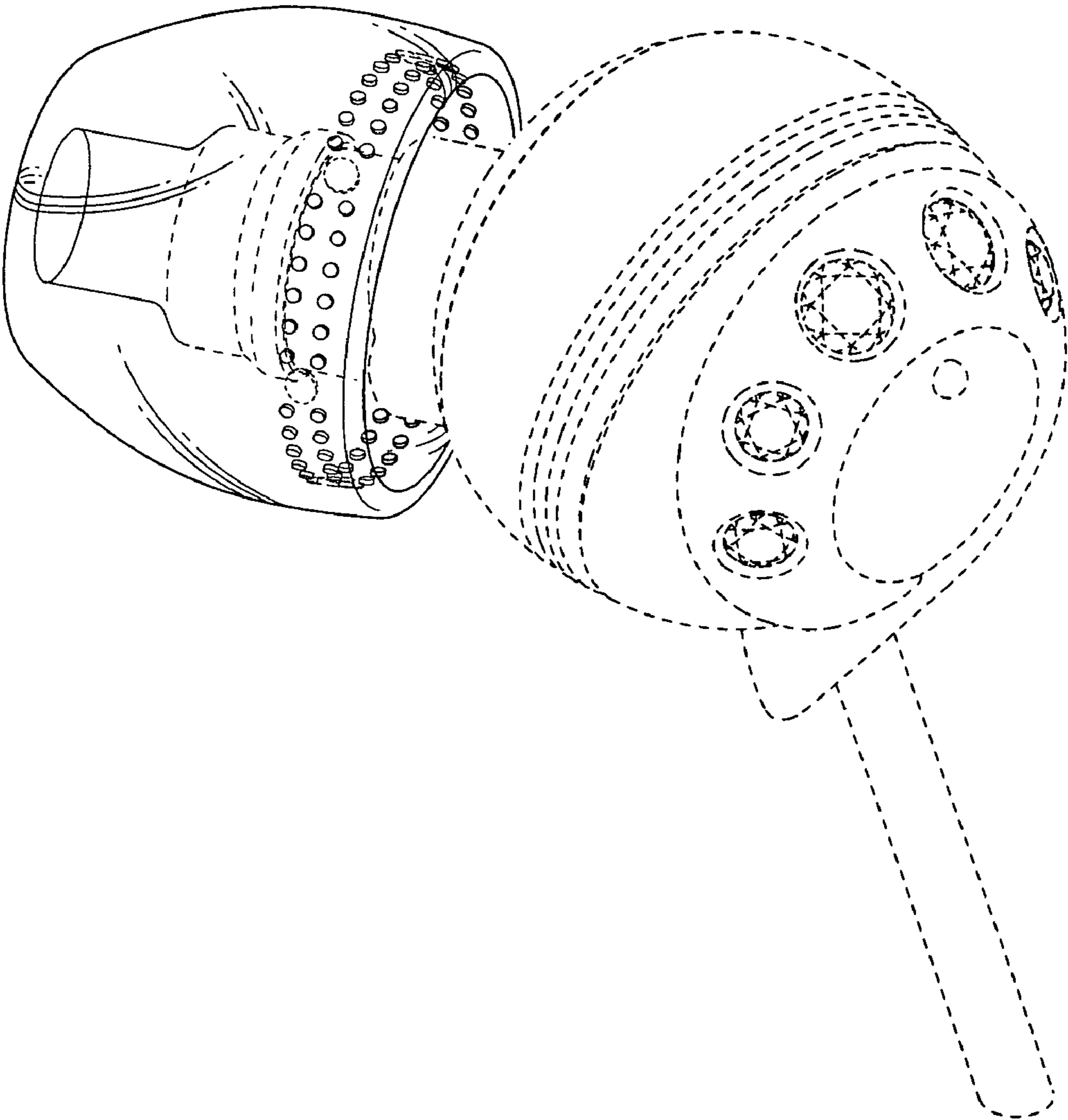

FIG.9

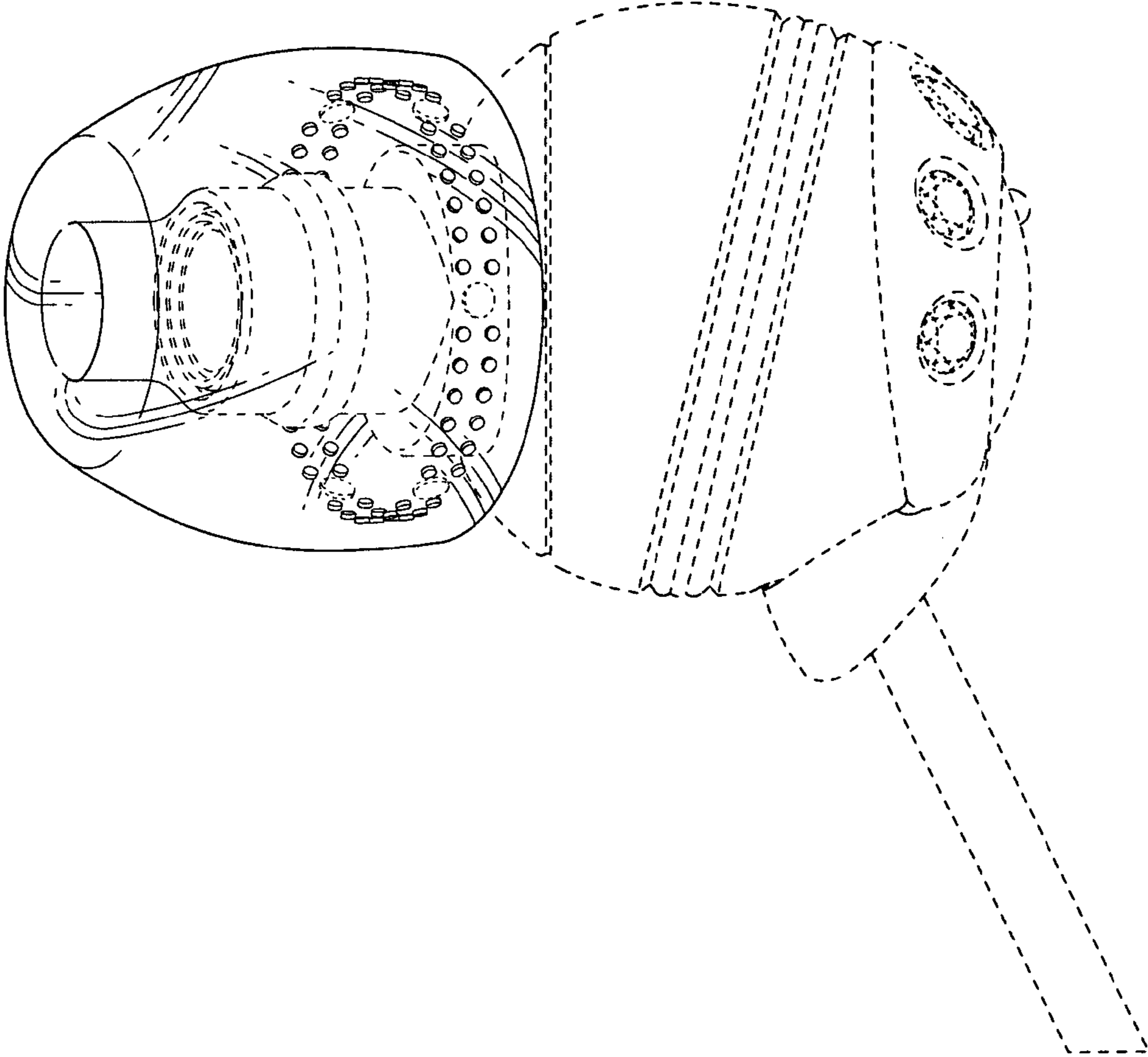

FIG.10

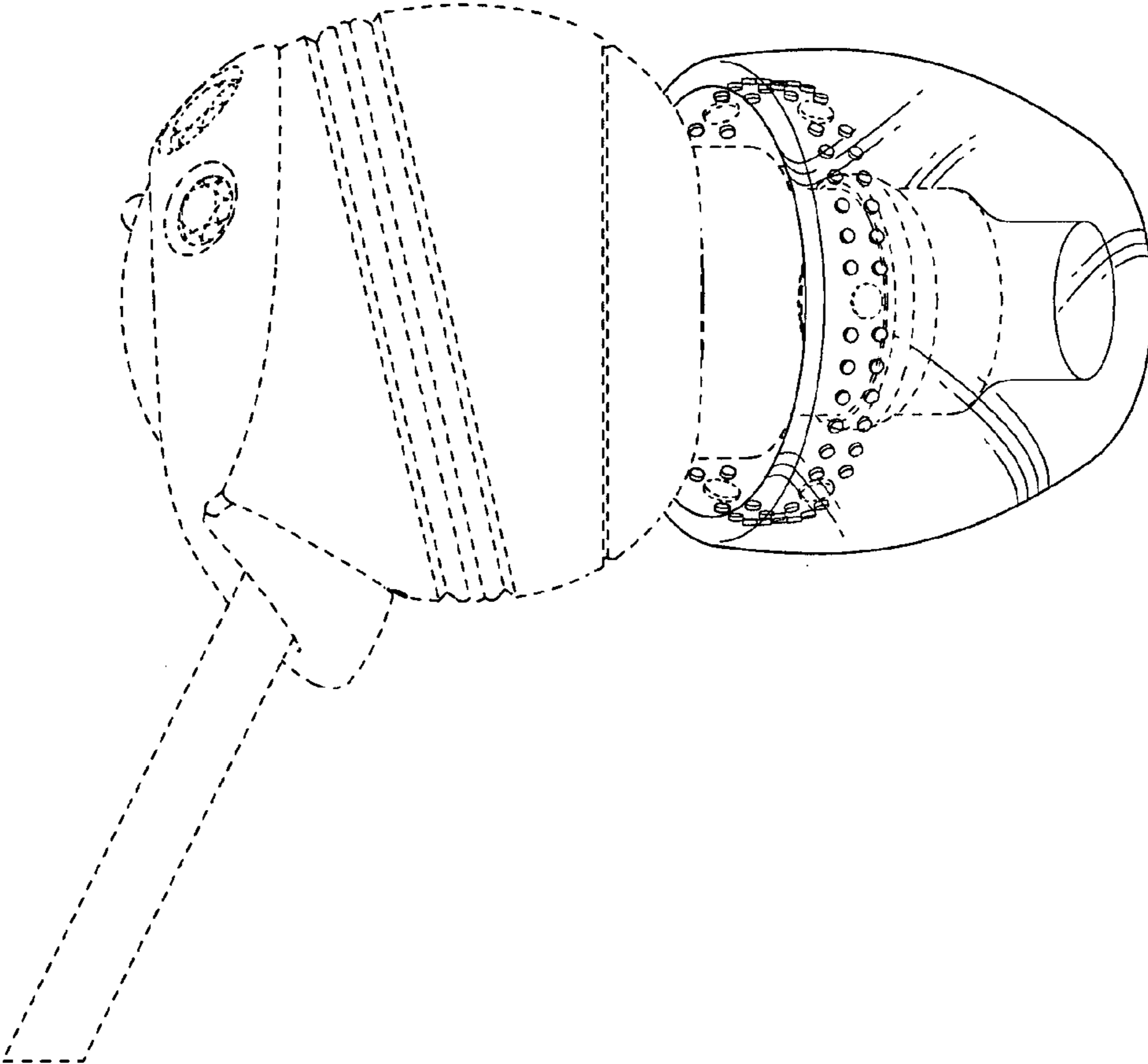

FIG.11

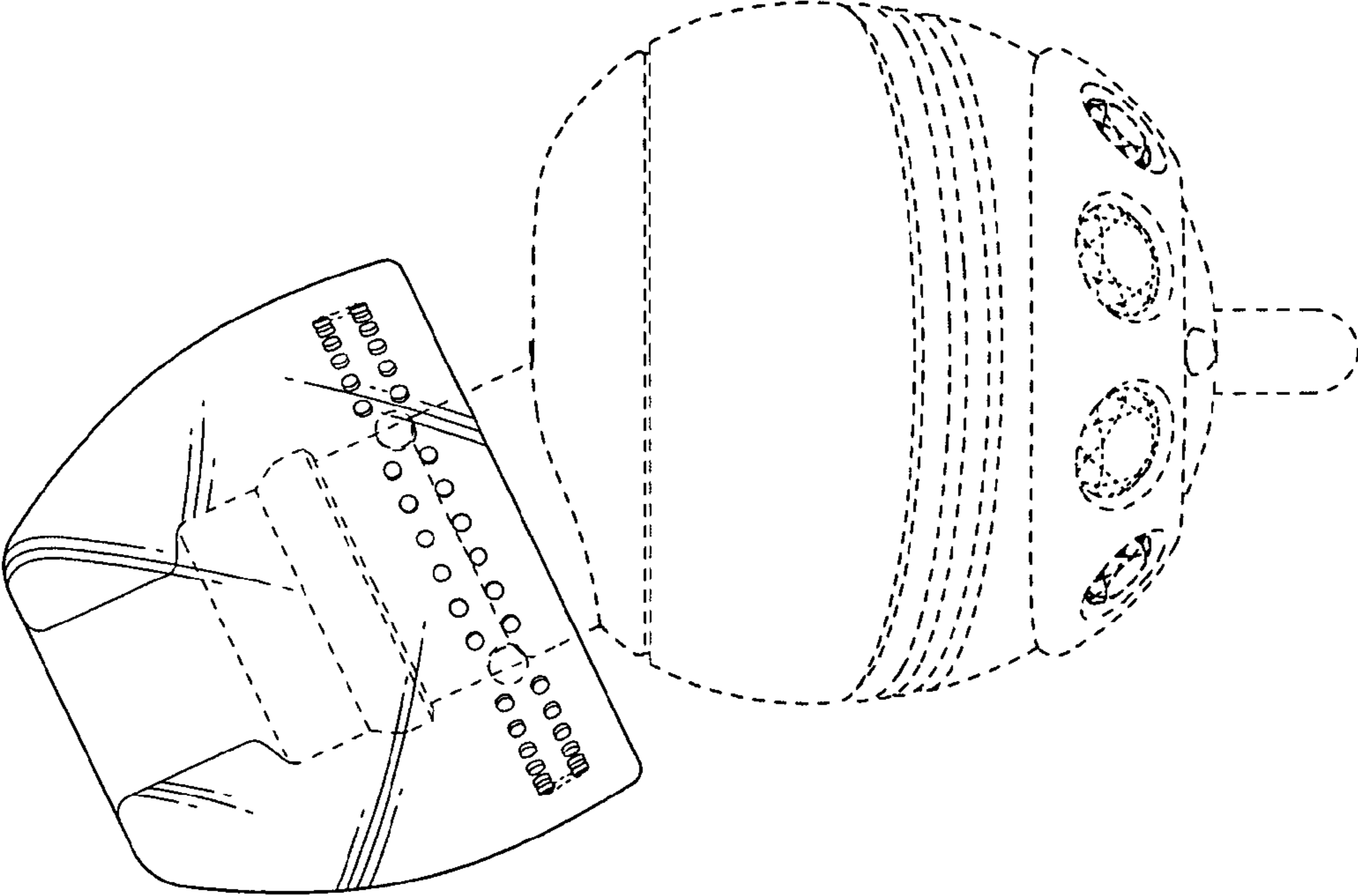

FIG.12

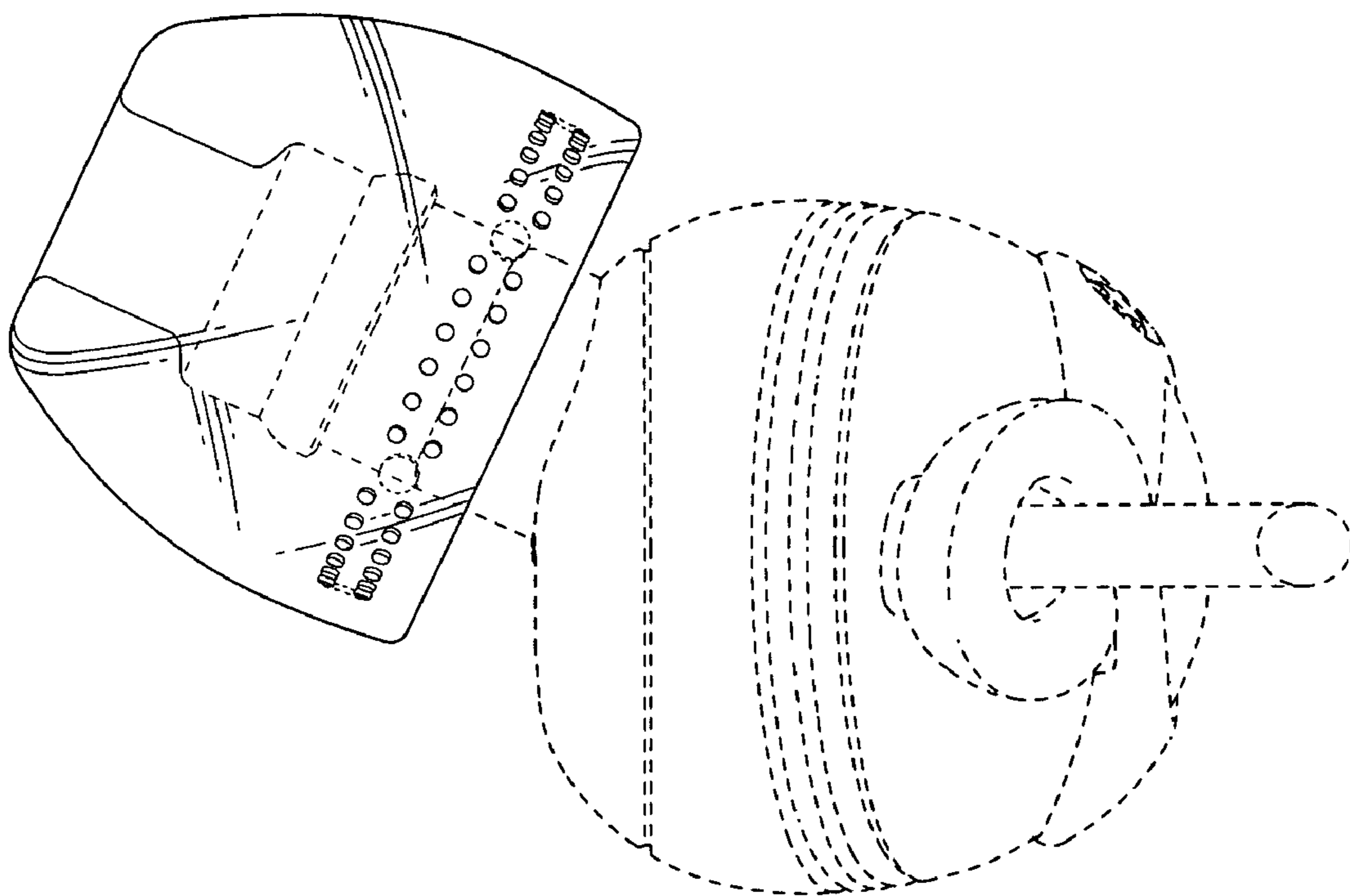

FIG.13

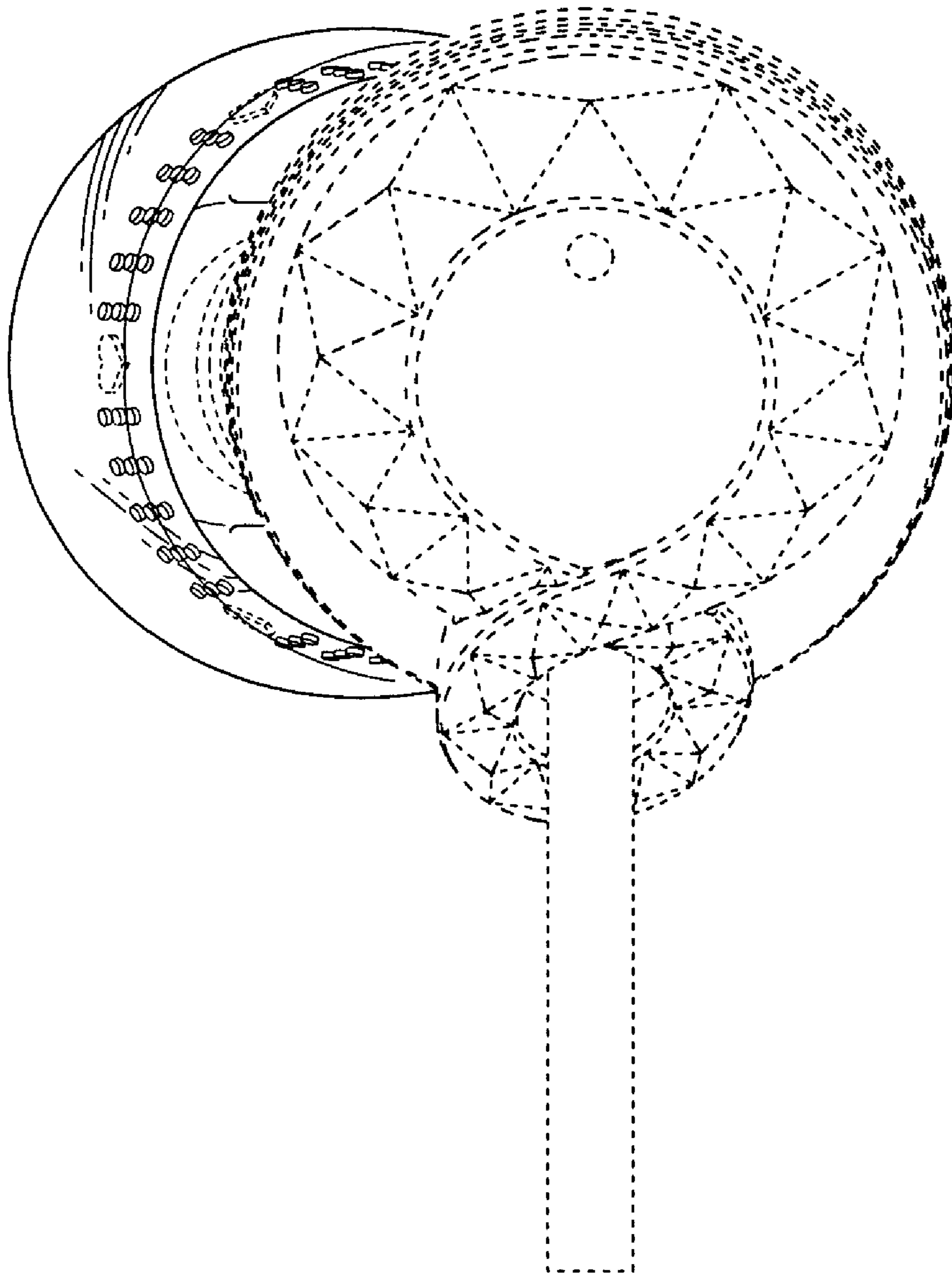

FIG.14

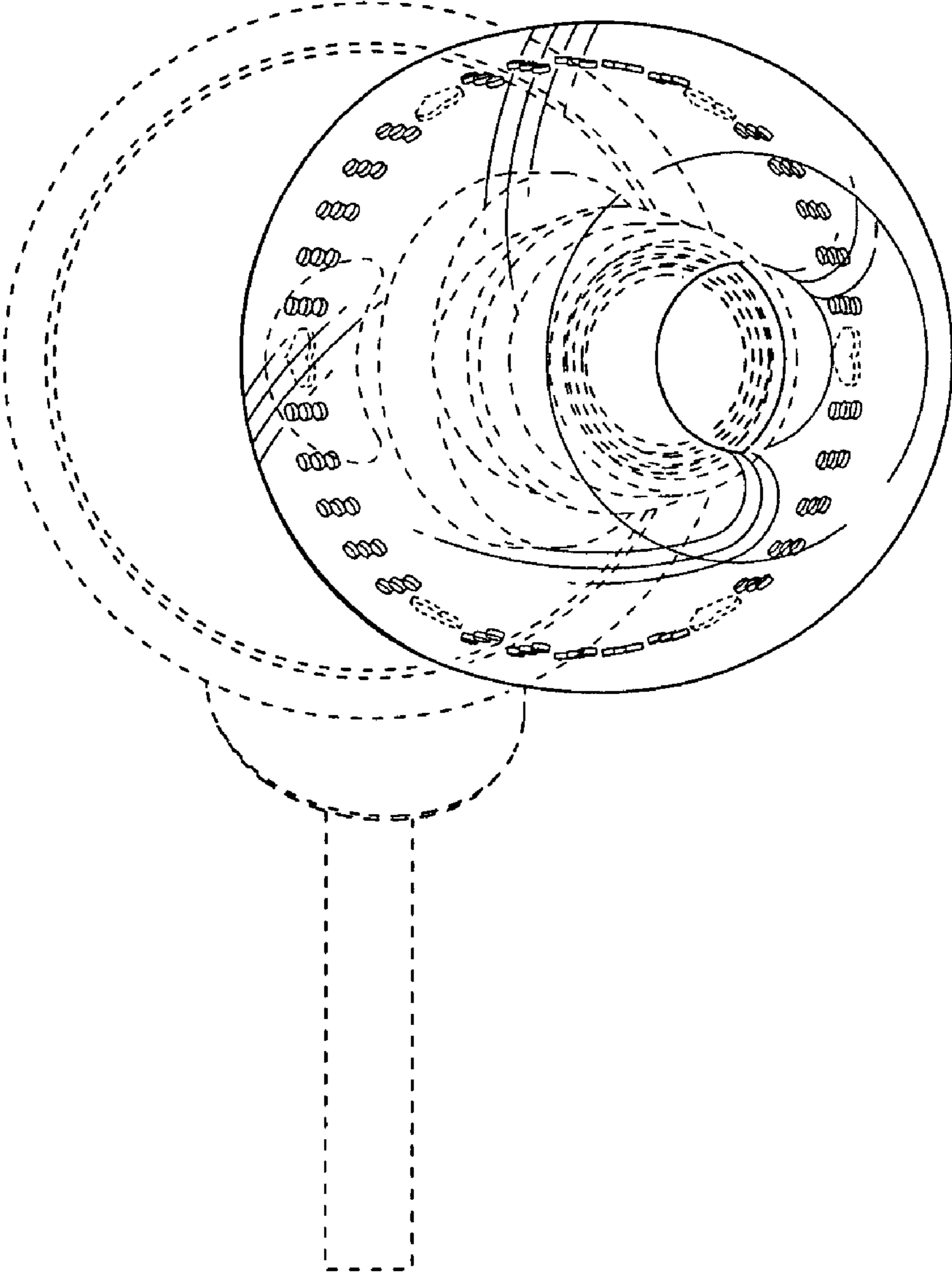

FIG.15

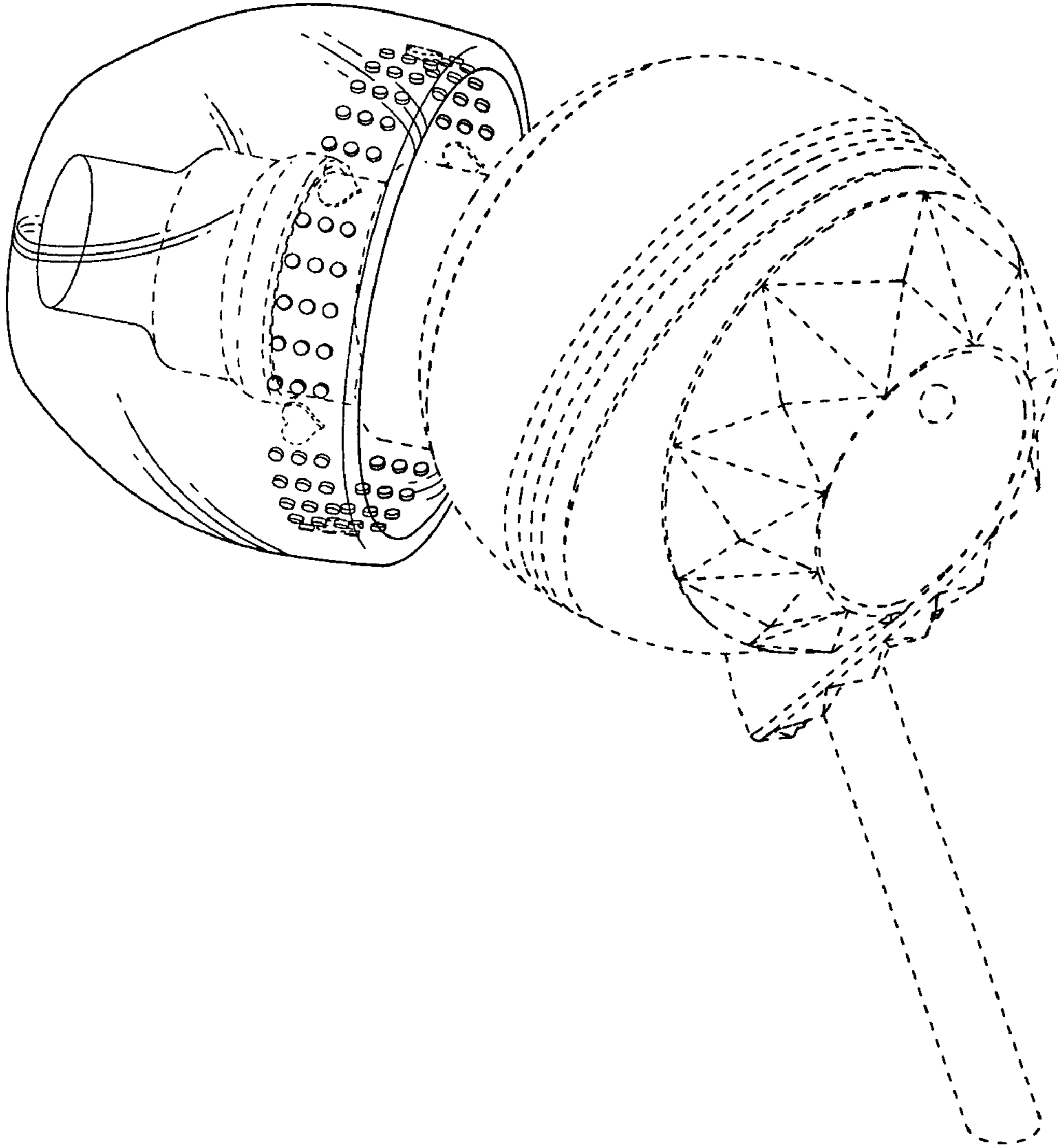



FIG.16

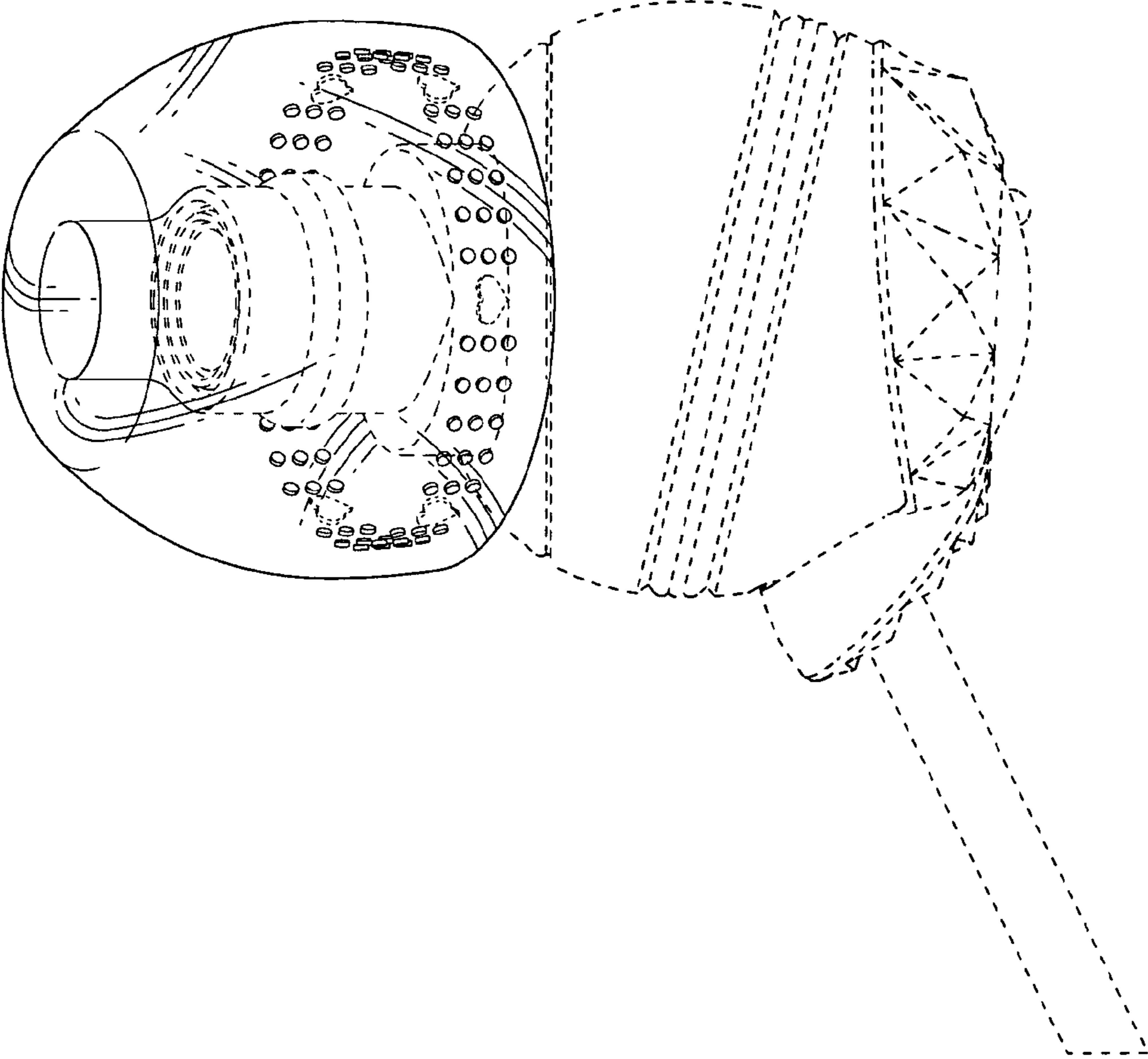

FIG.17

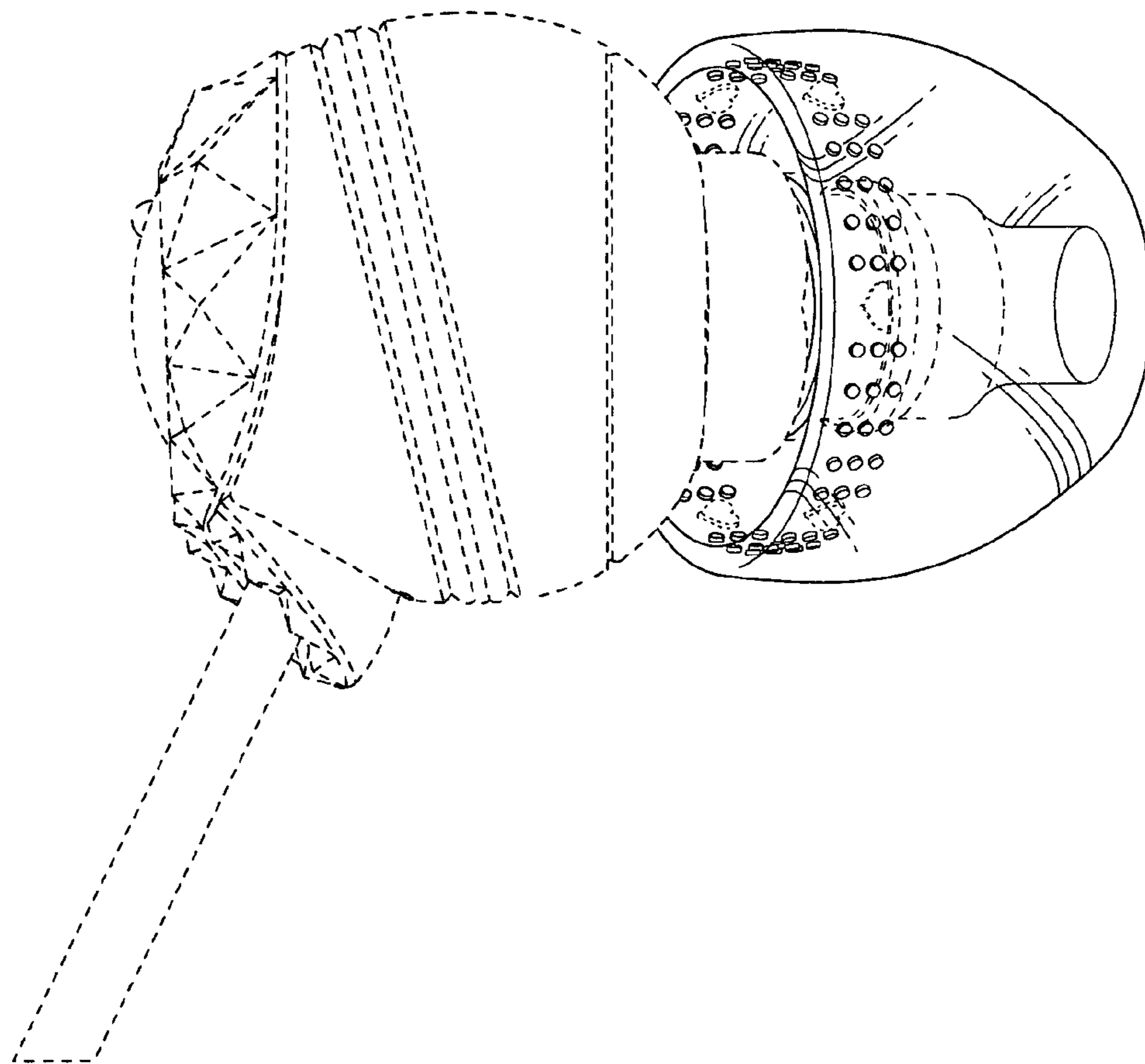

FIG.18

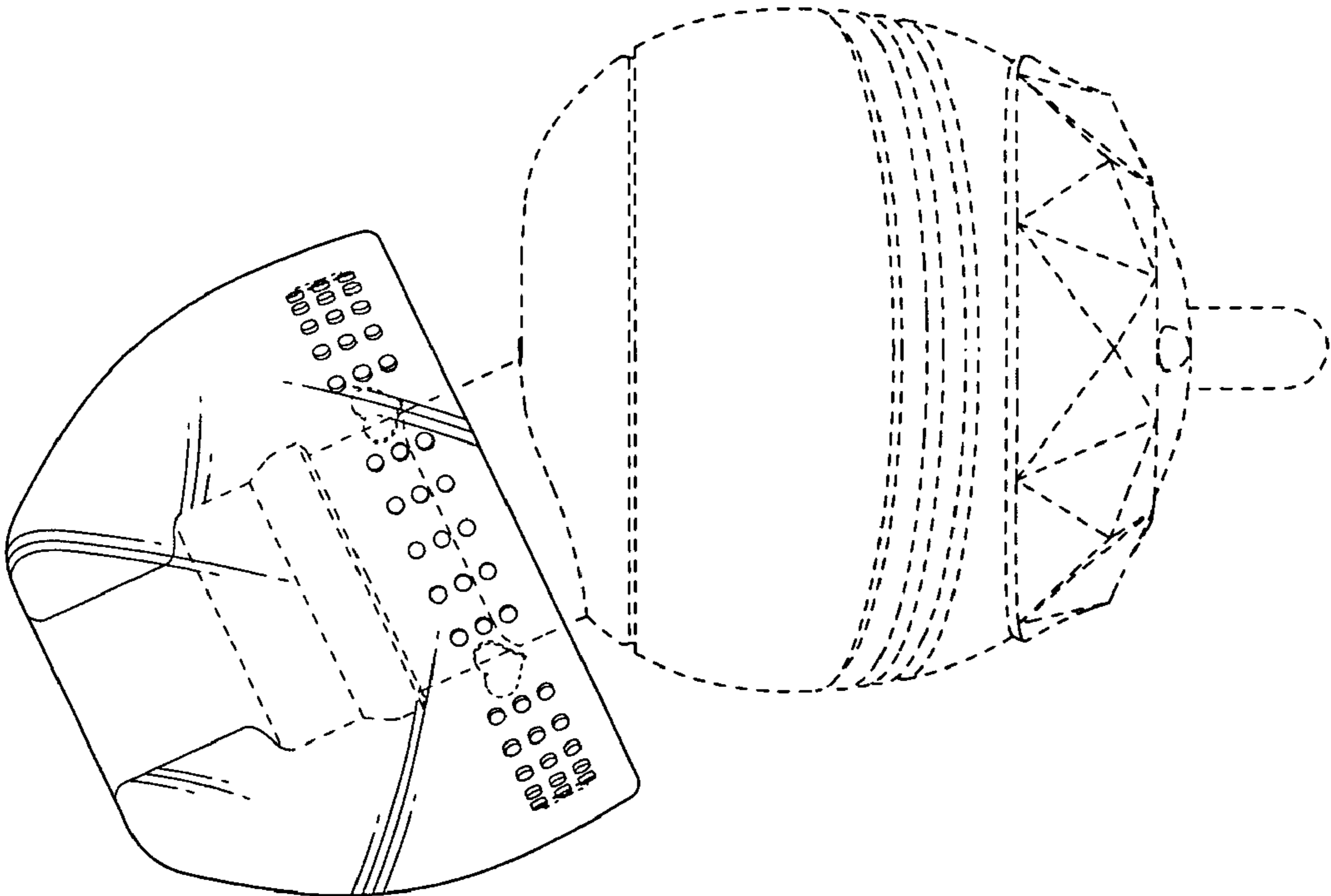

FIG.19

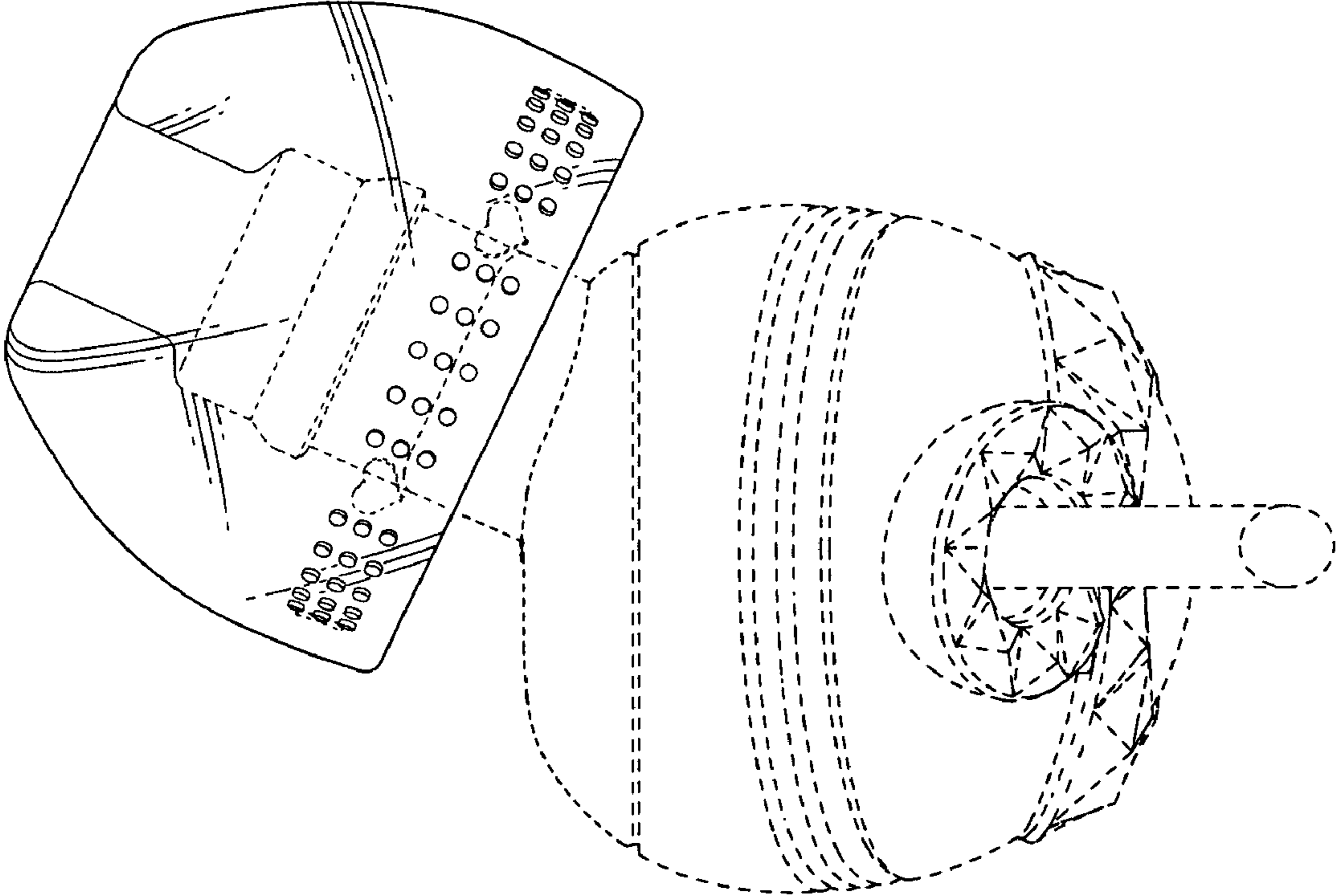

FIG.20

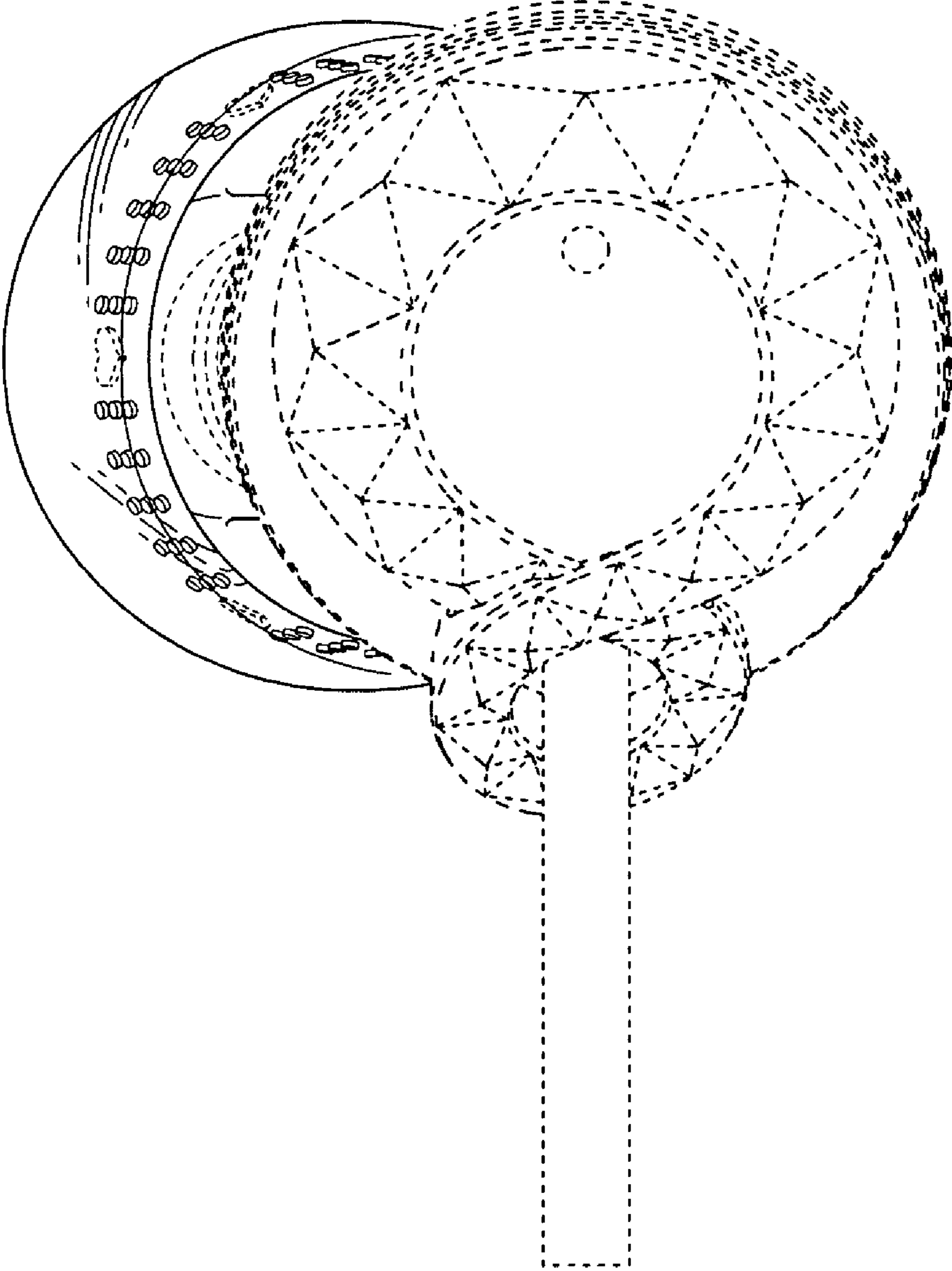

FIG.21

