



US00D653173S

(12) **United States Design Patent**
Dolesh

(10) **Patent No.:** **US D653,173 S**

(45) **Date of Patent:** **** Jan. 31, 2012**

(54) **TRUCK CAB**

(75) Inventor: **William L. Dolesh**, Richmond, IN (US)

(73) Assignee: **Autocar Industries, LLC**, Hagerstown, IN (US)

(**) Term: **14 Years**

(21) Appl. No.: **29/343,708**

(22) Filed: **Sep. 17, 2009**

(51) **LOC (9) Cl.** **12-16**

(52) **U.S. Cl.** **D12/96; D15/30**

(58) **Field of Classification Search** D12/93,
D12/96, 97, 99; D15/10, 28, 23, 30; 180/89.16,
180/89.18, 89.19, 89.1, 89.12, 89.13; 296/183.1,
296/190.1, 190.01; 187/237, 238, 414; 414/680,
414/685-688, 694

See application file for complete search history.

(56) **References Cited**

U.S. PATENT DOCUMENTS

| | | | | |
|-----------|---|-----------|-----------------|--------------|
| 5,330,222 | A | 7/1994 | Halverson | |
| 5,579,860 | A | 12/1996 | Halverson | |
| D389,984 | S | 1/1998 | Johansson | |
| D502,296 | S | * 2/2005 | Cunningham | D12/96 |
| D529,411 | S | * 10/2006 | Fairbairn | D12/96 |
| D570,381 | S | * 6/2008 | Kato | D15/30 |
| D571,074 | S | * 6/2008 | Buchmann et al. | D34/35 |
| D594,480 | S | * 6/2009 | Gicquel et al. | D15/30 |

| | | | | |
|----------|---|----------|-------------------|--------------|
| D598,032 | S | * 8/2009 | Nakanishi et al. | D15/30 |
| D607,904 | S | * 1/2010 | Reisenauer et al. | D15/30 |
| D607,905 | S | * 1/2010 | Reisenauer et al. | D15/30 |

* cited by examiner

Primary Examiner — Melody N Brown

(74) *Attorney, Agent, or Firm* — Banner & Witcoff, Ltd.

(57) **CLAIM**

I claim the ornamental design for a truck cab, as shown and described.

DESCRIPTION

FIG. 1 is a front perspective view of a truck cab showing our new design;

FIG. 2 is another perspective view of a truck cab shown in FIGS. 1 and 2;

FIG. 3 is a front view of the truck cab shown in FIGS. 1 and 2;

FIG. 4 is a right side view of the truck cab shown in FIGS. 1 and 2;

FIG. 5 is a left side view of the truck cab shown in FIGS. 1 and 2;

FIG. 6 is a rear view of the truck cab shown in FIGS. 1 and 2; and,

FIG. 7 is a top view of the truck cab shown in FIGS. 1 and 2. The bottom view is plain and unornamented.

The truck vehicle portions shown in broken lines are for illustrative purposes only and form no part of the claimed design.

1 Claim, 4 Drawing Sheets

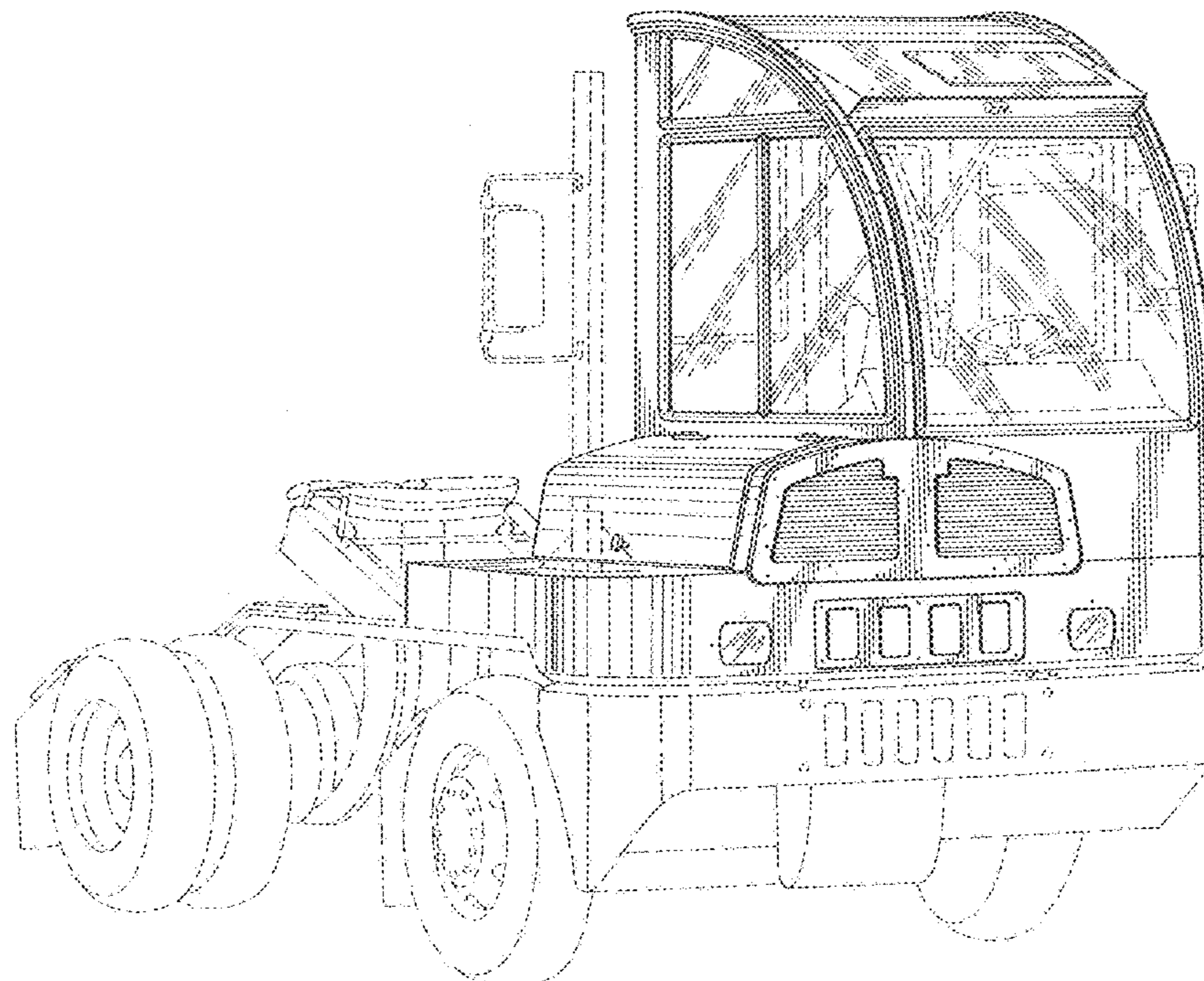

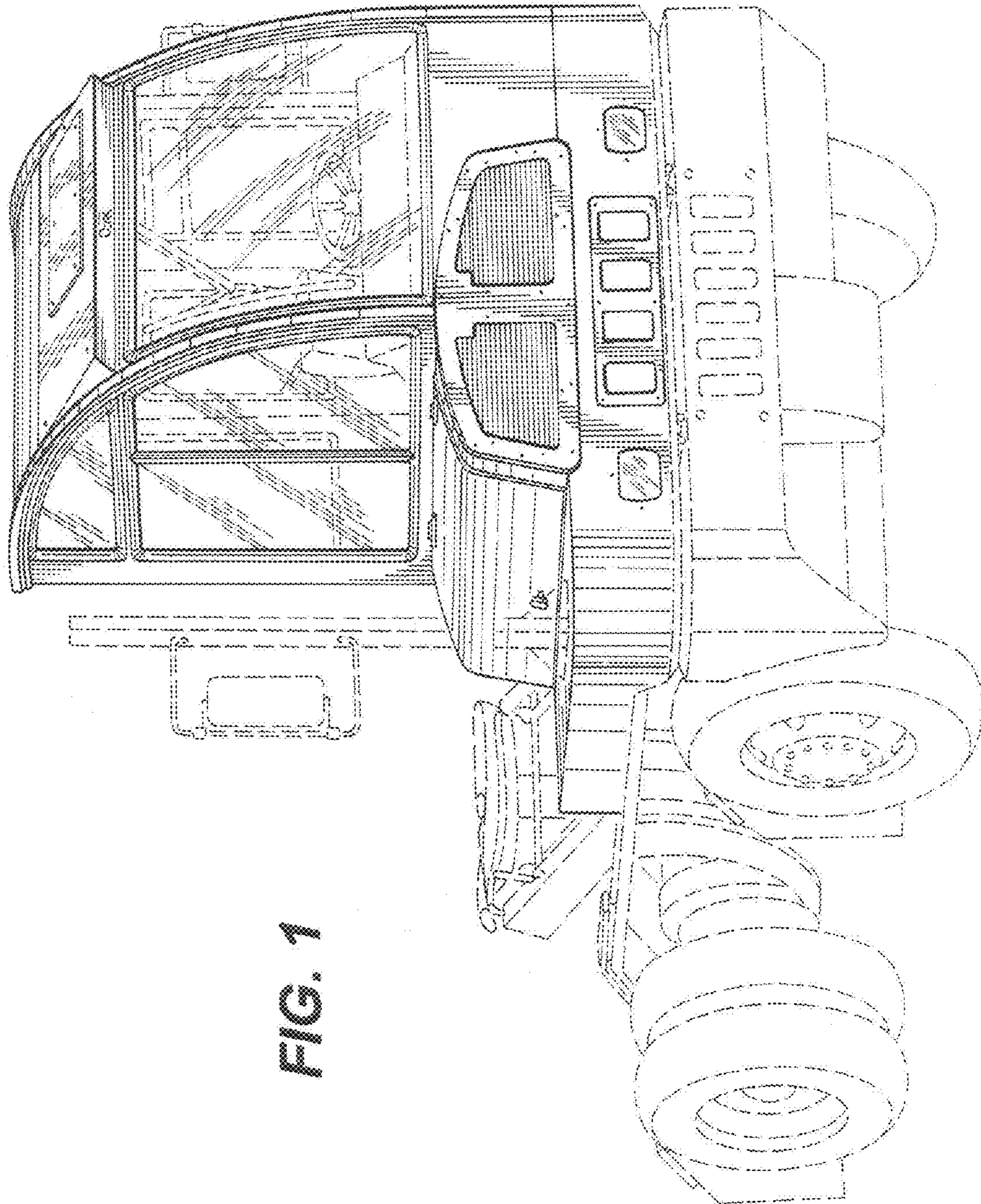

FIG. 1

FIG. 3

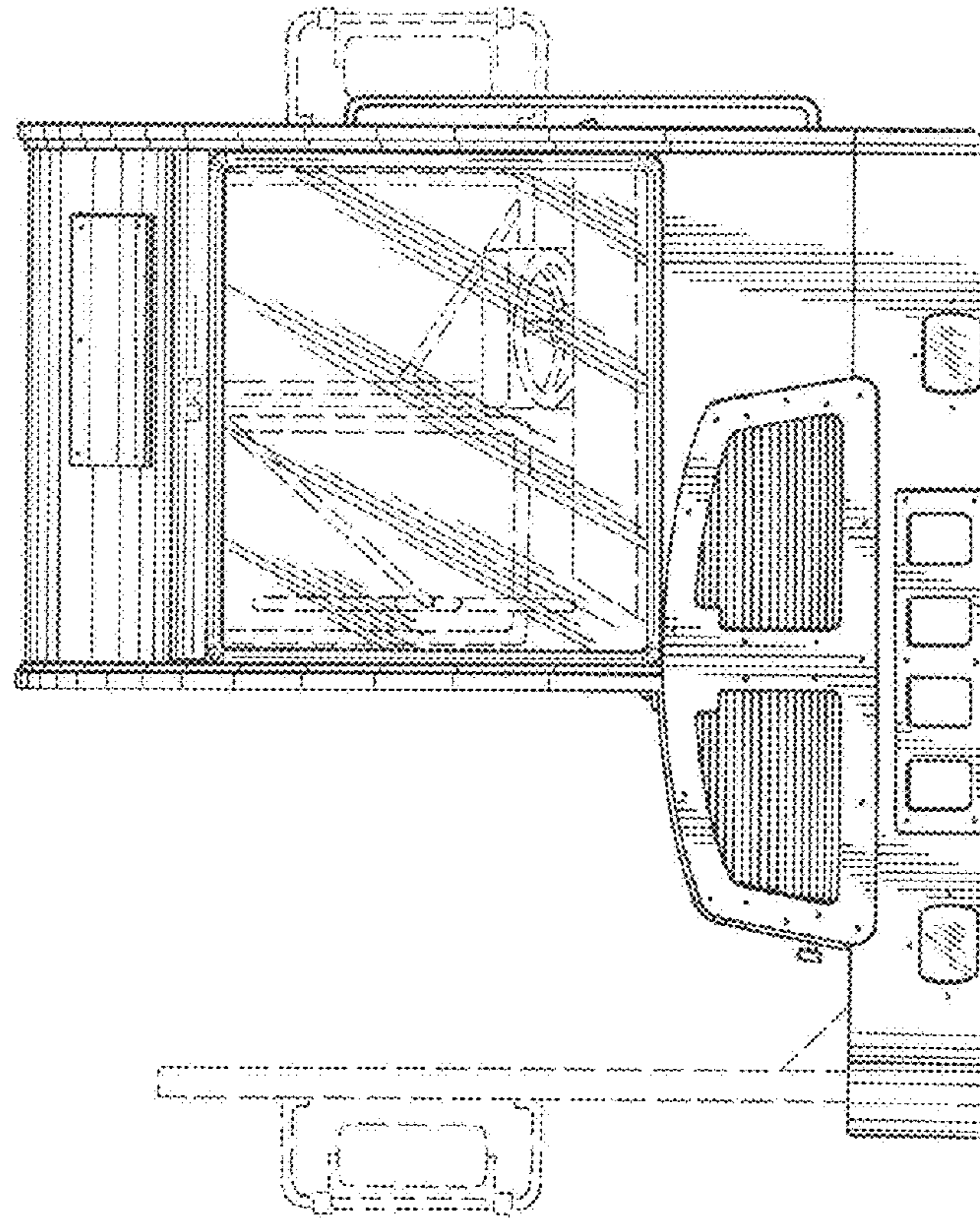

FIG. 2

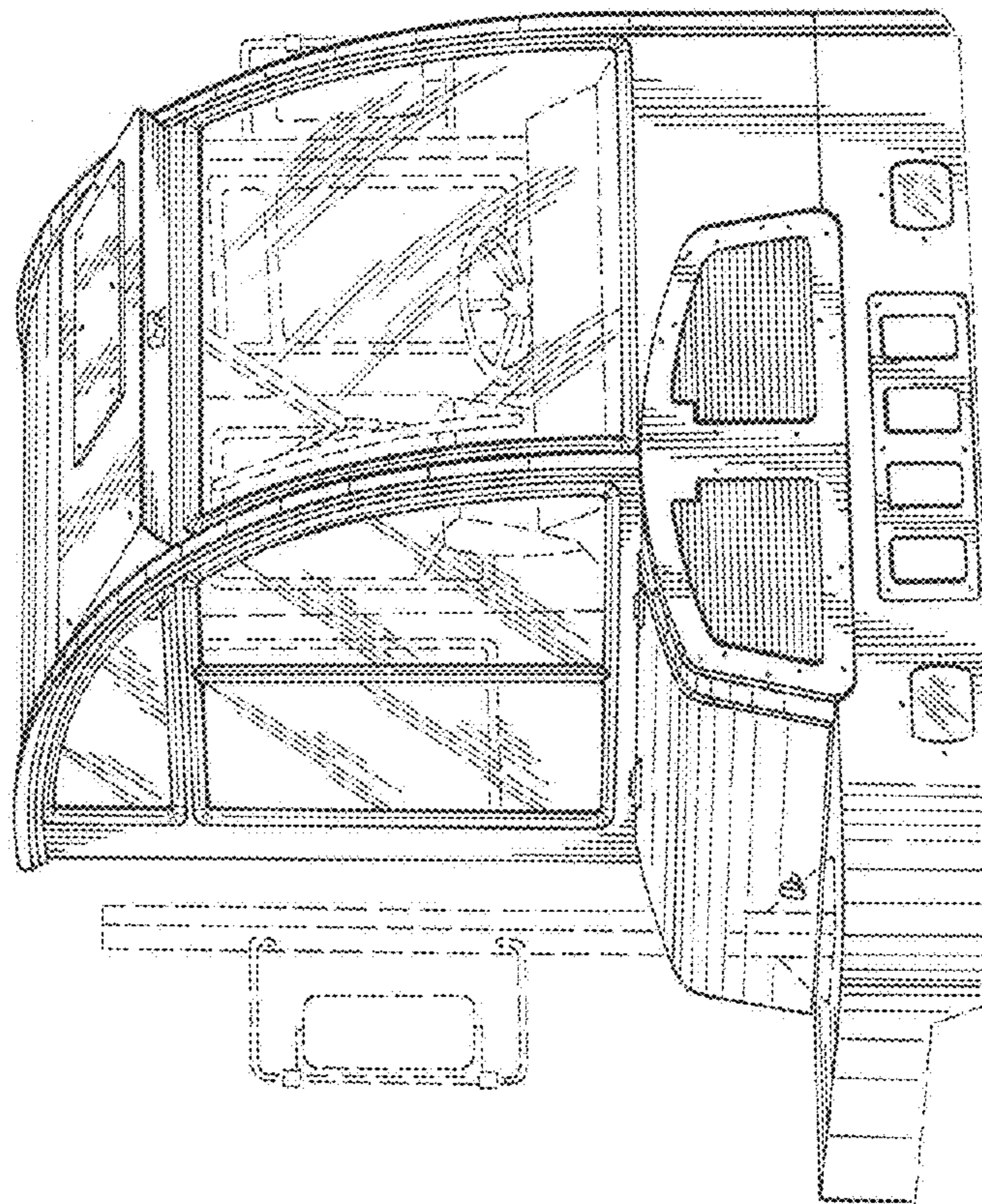

FIG. 5

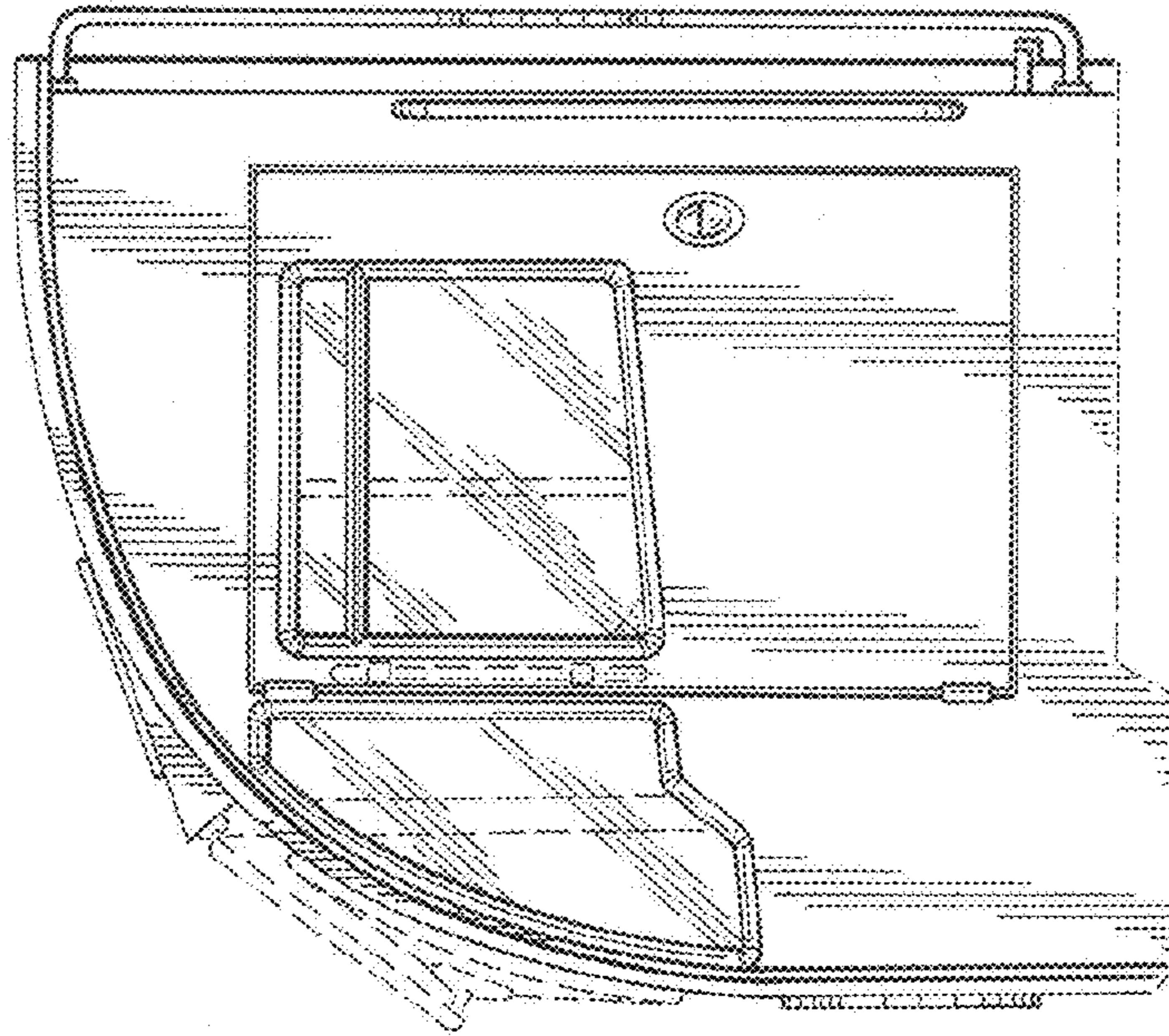

FIG. 4

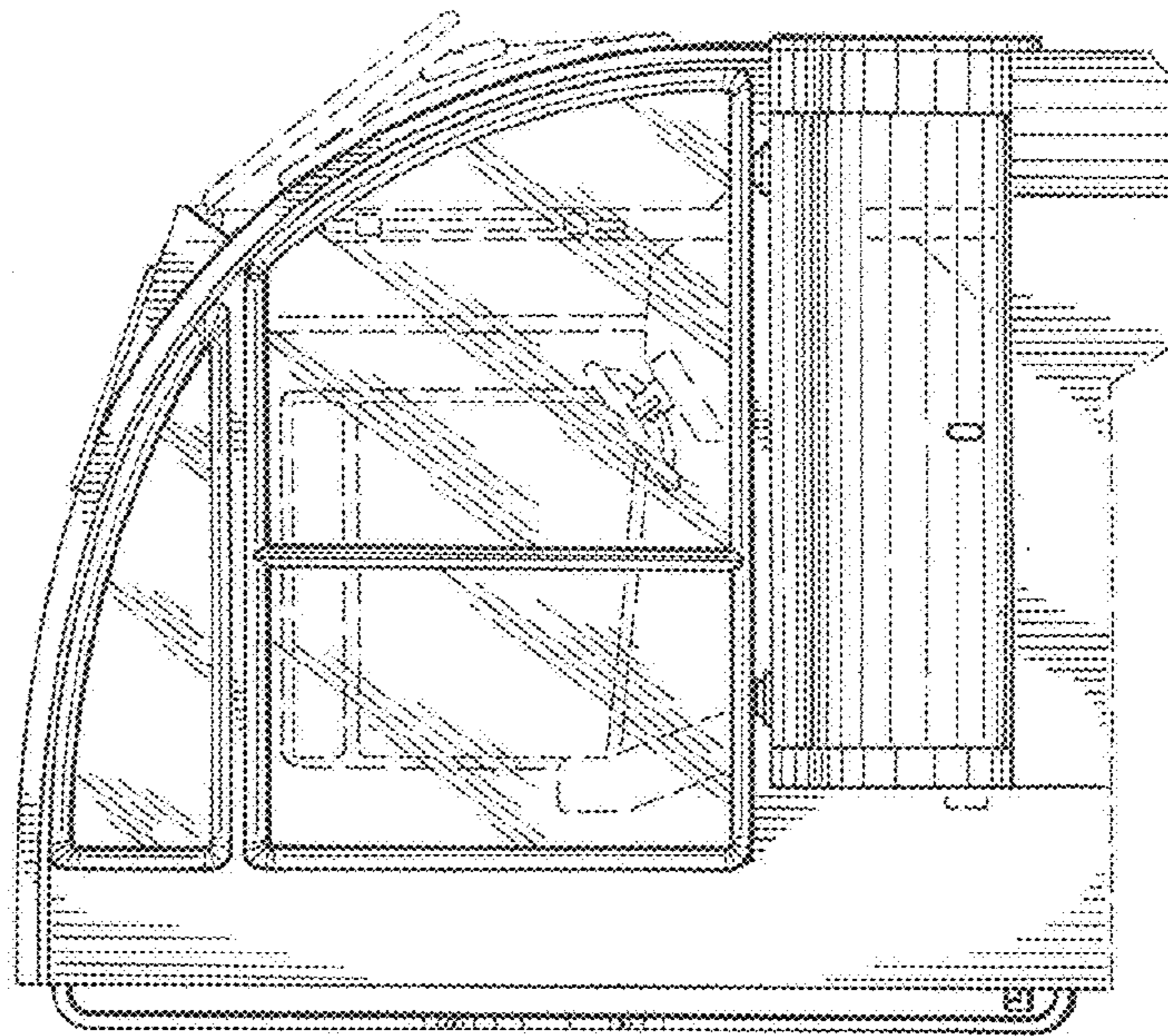

FIG. 6

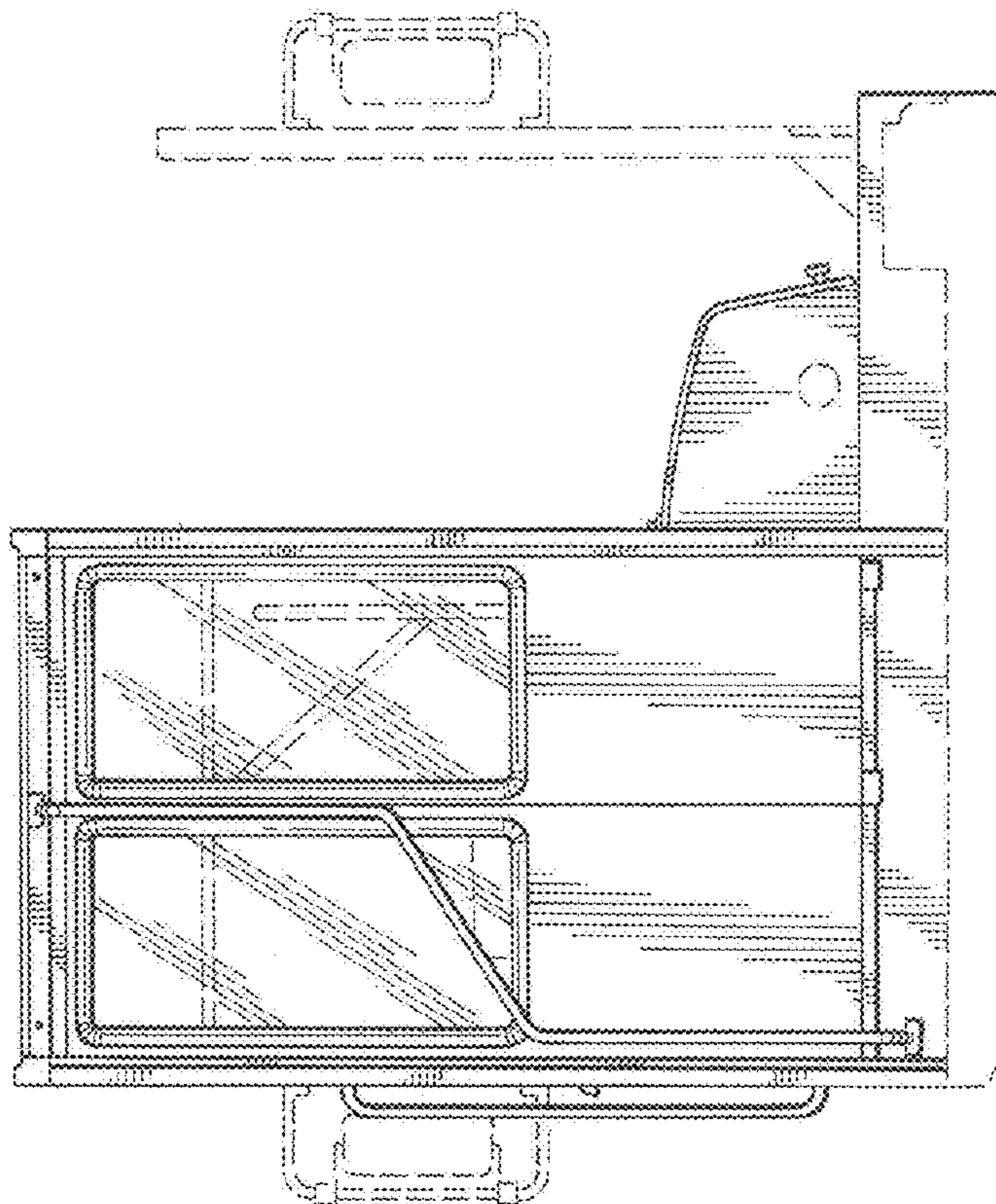

FIG. 7

