

US00D652777S

(12) **United States Design Patent**  
**Spogis**

(10) **Patent No.:** **US D652,777 S**  
(45) **Date of Patent:** **\*\* Jan. 24, 2012**

(54) **WHEEL OR WHEEL COVER**

(75) Inventor: **Roberts Spogis**, Hallensberg-Hesborn (DE)

(73) Assignee: **Daimler AG**, Stuttgart (DE)

(\*\*) Term: **14 Years**

(21) Appl. No.: **29/384,810**

(22) Filed: **Feb. 4, 2011**

(30) **Foreign Application Priority Data**

Aug. 5, 2010 (EM) ..... 001740580-0001

(51) **LOC (9) Cl.** ..... **12-16**

(52) **U.S. Cl.** ..... **D12/211**

(58) **Field of Classification Search** ..... D12/204-213;  
301/37.101, 64.101, 65, 64.201  
See application file for complete search history.

(56) **References Cited**

**U.S. PATENT DOCUMENTS**

|              |         |             |       |         |
|--------------|---------|-------------|-------|---------|
| D510,554 S * | 10/2005 | Markefka    | ..... | D12/211 |
| D544,822 S * | 6/2007  | Walbey, Jr. | ..... | D12/211 |
| D567,735 S * | 4/2008  | Young       | ..... | D12/209 |
| D569,776 S * | 5/2008  | Hieke       | ..... | D12/211 |
| D582,328 S * | 12/2008 | Hieke       | ..... | D12/209 |
| D582,335 S * | 12/2008 | Rak         | ..... | D12/211 |

|              |         |                   |       |         |
|--------------|---------|-------------------|-------|---------|
| D594,803 S * | 6/2009  | Pollmann          | ..... | D12/211 |
| D602,834 S * | 10/2009 | Dilber            | ..... | D12/211 |
| D603,779 S * | 11/2009 | Futschik et al.   | ..... | D12/211 |
| D604,221 S * | 11/2009 | Krisch            | ..... | D12/211 |
| D613,657 S * | 4/2010  | Cortes            | ..... | D12/209 |
| D618,150 S * | 6/2010  | Hilpert           | ..... | D12/209 |
| D621,317 S * | 8/2010  | Antoniadis et al. | ..... | D12/209 |
| D623,115 S * | 9/2010  | Juergens et al.   | ..... | D12/211 |
| D629,346 S * | 12/2010 | Szews             | ..... | D12/211 |
| D635,904 S * | 4/2011  | Futschik et al.   | ..... | D12/209 |
| D639,716 S * | 6/2011  | Juergens et al.   | ..... | D12/211 |
| D644,585 S * | 9/2011  | Antoniadis et al. | ..... | D12/209 |
| D644,588 S * | 9/2011  | Schweizer         | ..... | D12/211 |

\* cited by examiner

*Primary Examiner* — Stacia Cadmus

(74) *Attorney, Agent, or Firm* — Crowell & Moring LLP

(57) **CLAIM**

The ornamental design for a wheel or wheel cover, as shown and described.

**DESCRIPTION**

FIG. 1 is a front view of a wheel or wheel cover according to my design; and,

FIG. 2 is a perspective view thereof.

The broken line showing of the rear of the wheel, the valve stem hole, and the bolt holes and the center cap in the central hub area is included for the purpose of illustrating environment and forms no part of the claimed design.

**1 Claim, 1 Drawing Sheet**

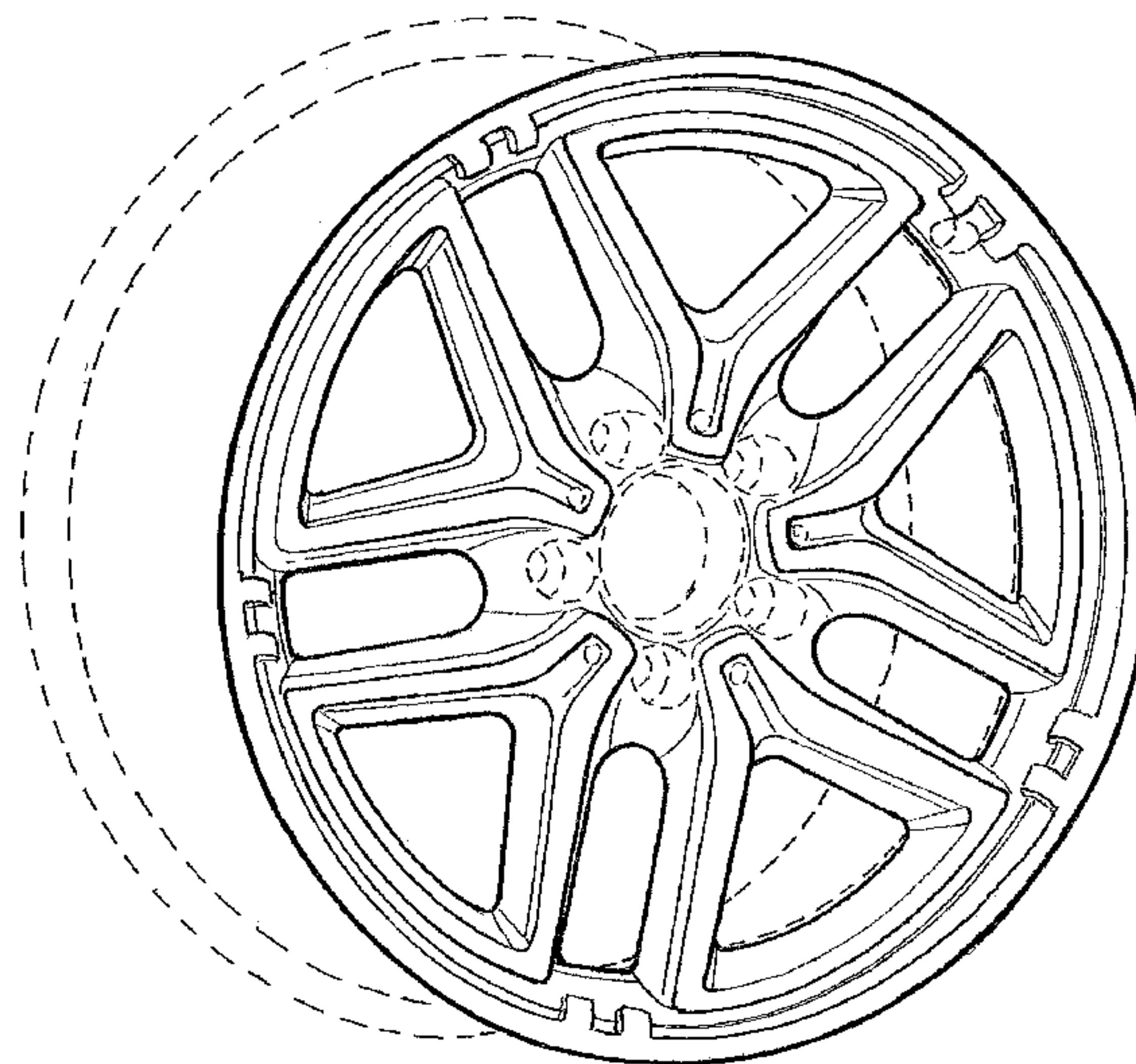
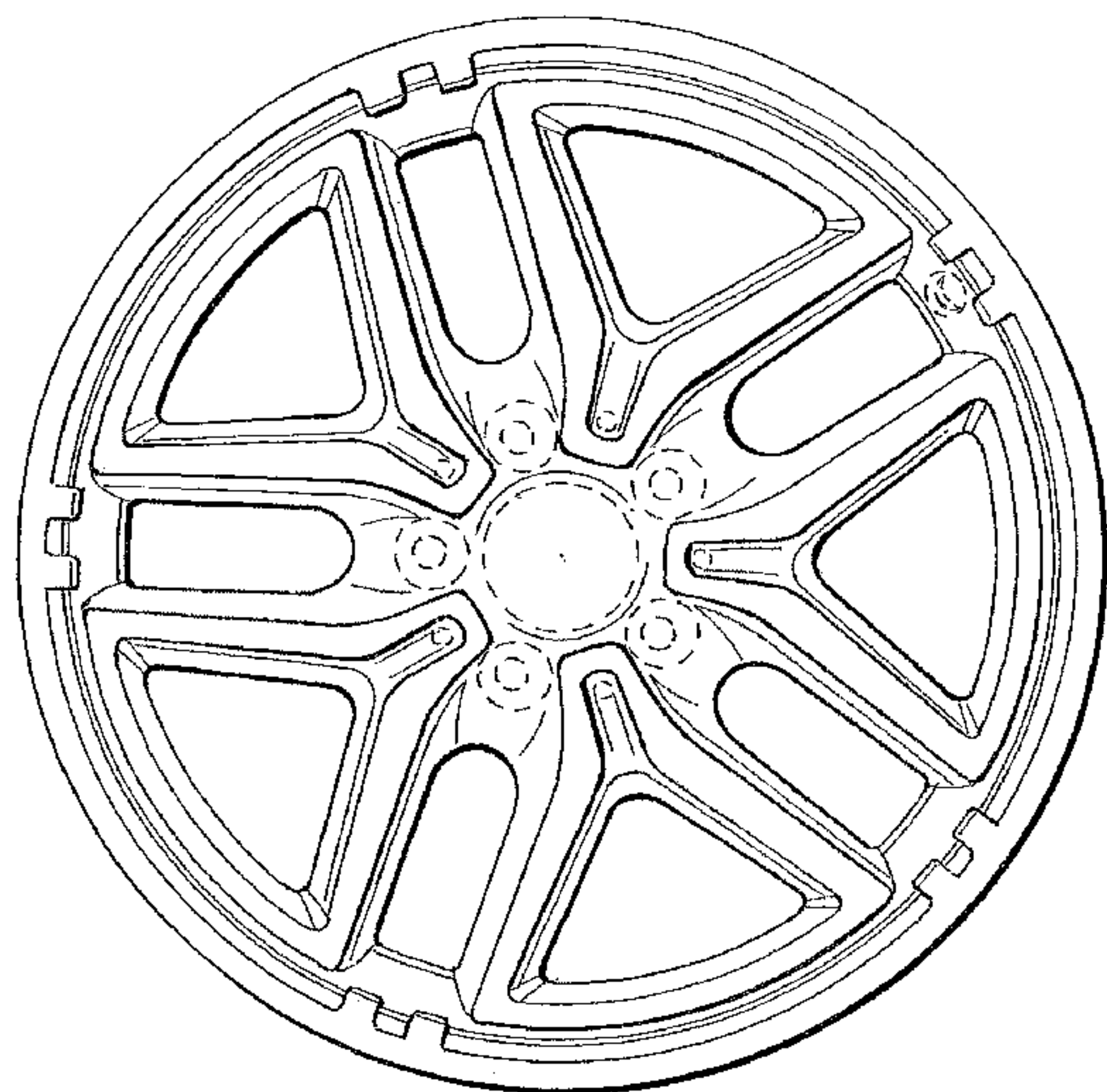

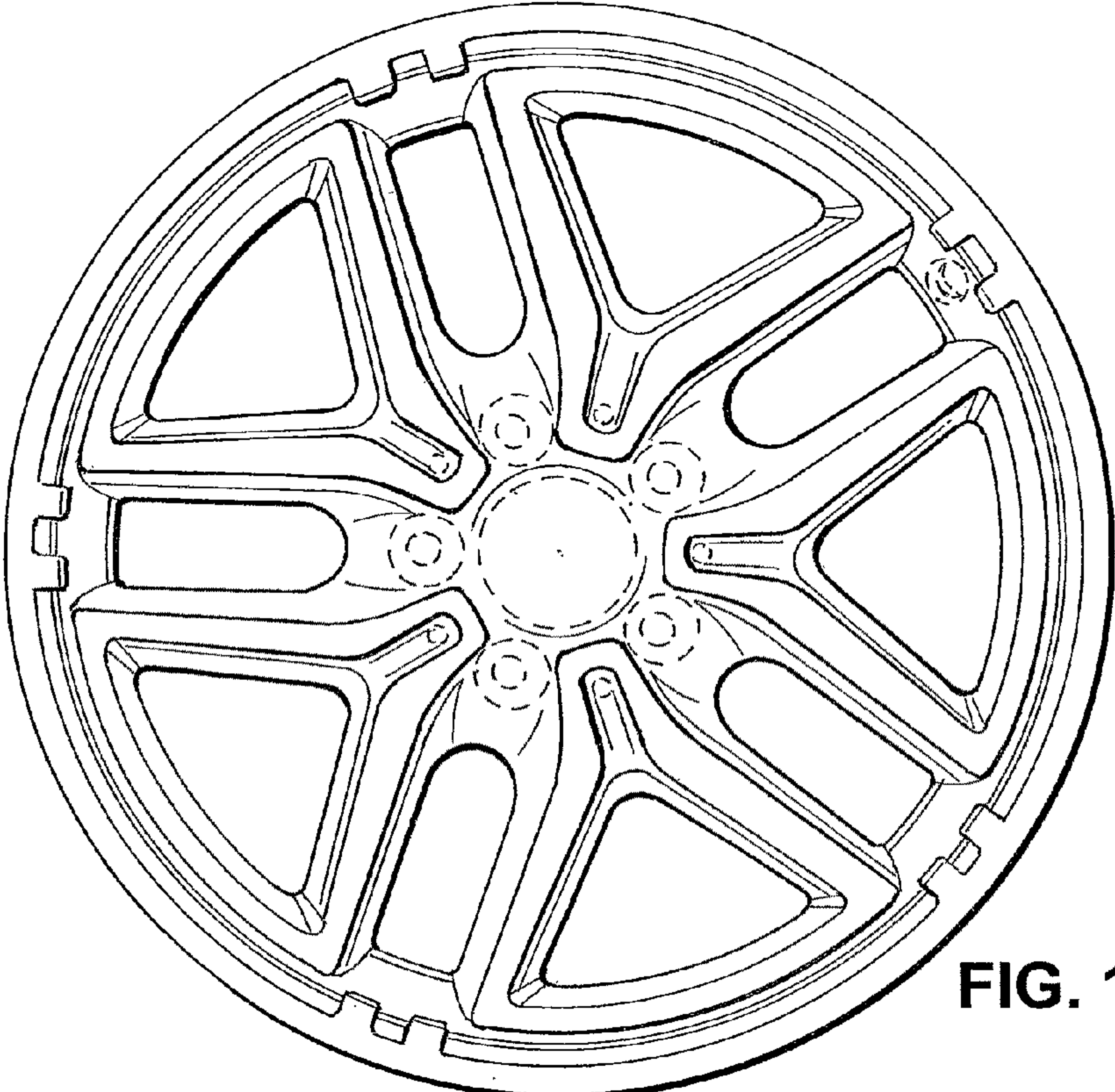

FIG. 1

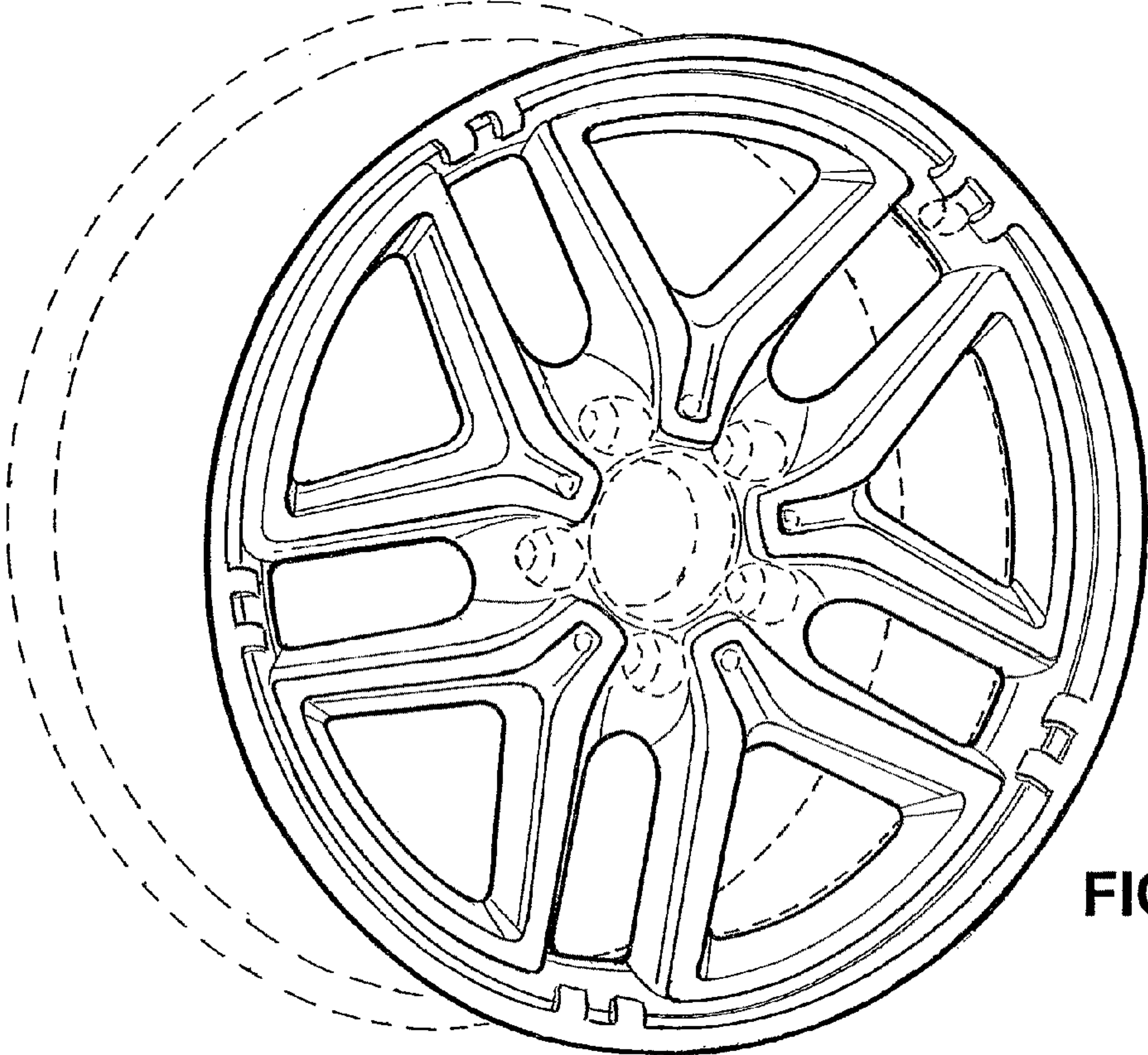

FIG. 2