



US00D652770S

(12) **United States Design Patent**
Hatano et al.

(10) **Patent No.:** **US D652,770 S**
(45) **Date of Patent:** **** Jan. 24, 2012**

(54) **ELECTRIC BRAKE ACTUATOR FOR VEHICLES**

(75) Inventors: **Kunimichi Hatano**, Wako (JP); **Naoto Ohkubo**, Wako (JP); **Takashi Nishioka**, Wako (JP); **Kazuyoshi Akutsu**, Wako (JP); **Takaaki Ohnishi**, Wako (JP); **Arata Inoue**, Wako (JP)

(73) Assignee: **Honda Motor Co., Ltd.**, Tokyo (JP)

(**) Term: **14 Years**

(21) Appl. No.: **29/390,831**

(22) Filed: **Apr. 29, 2011**

(30) **Foreign Application Priority Data**

Nov. 2, 2010 (JP) 2010-026389

(51) **LOC (9) Cl.** **12-16**

(52) **U.S. Cl.** **D12/180**

(58) **Field of Classification Search** D12/180, D12/179; D15/5; 188/18 A, 11.5, 167, 170; 303/7, 10, 20, 87, 113.5, 114.1, 119.2, 119.3; 192/112 R, 90, 105 BB; 92/62-64, 80-82
See application file for complete search history.

(56) **References Cited**

U.S. PATENT DOCUMENTS

D545,737 S * 7/2007 Sherman D12/180
D546,252 S * 7/2007 Belisle D12/180

D581,330 S * 11/2008 Stender D12/180
D581,331 S * 11/2008 Stender D12/180
D584,666 S * 1/2009 Stender D12/180
D586,272 S * 2/2009 Schulz D12/180
7,493,992 B2 * 2/2009 Rogers 188/71.5
D600,179 S * 9/2009 Schulz et al. D12/180
D600,180 S * 9/2009 Schulz et al. D12/180
D601,933 S * 10/2009 Schulz et al. D12/180
D627,694 S * 11/2010 Schulz et al. D12/180
D638,336 S * 5/2011 Kelpe et al. D12/180
D638,528 S * 5/2011 Zhou et al. D23/318

* cited by examiner

Primary Examiner — Melody N Brown

(74) *Attorney, Agent, or Firm* — Birch, Stewart, Kolasch & Birch, LLP

(57) **CLAIM**

The ornamental design for a electric brake actuator for vehicles, as shown and described.

DESCRIPTION

FIG. 1 is a front view of an electric brake actuator for vehicles showing our new design;
FIG. 2 is a rear view thereof;
FIG. 3 is a top view thereof;
FIG. 4 is a bottom view thereof
FIG. 5 is a right side view thereof;
FIG. 6 is a left side view thereof;
FIG. 7 is a front perspective view thereof as seen from the top left side; and,
FIG. 8 is a rear perspective view thereof as seen from the bottom right side.

1 Claim, 4 Drawing Sheets

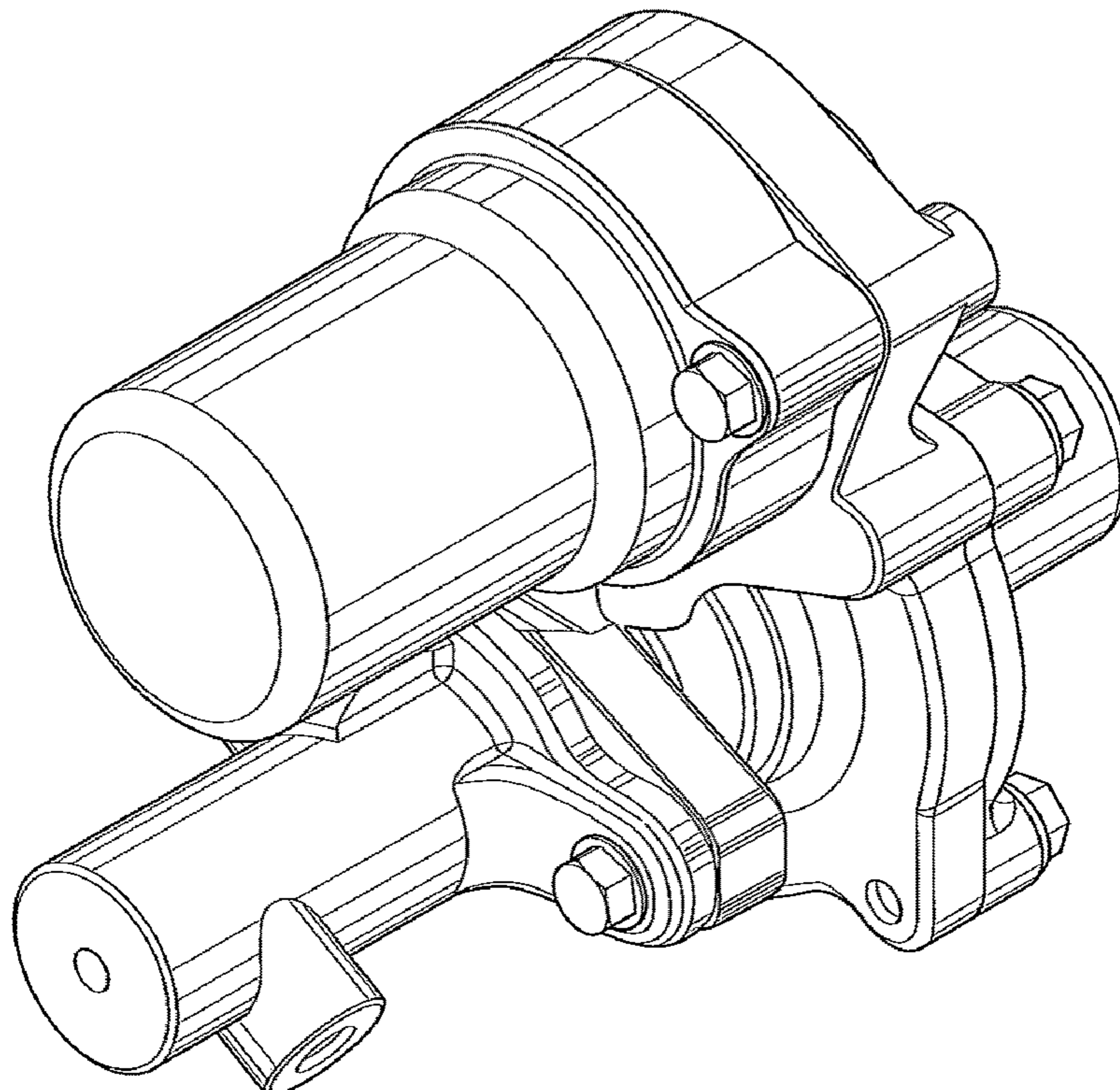

FIG.1

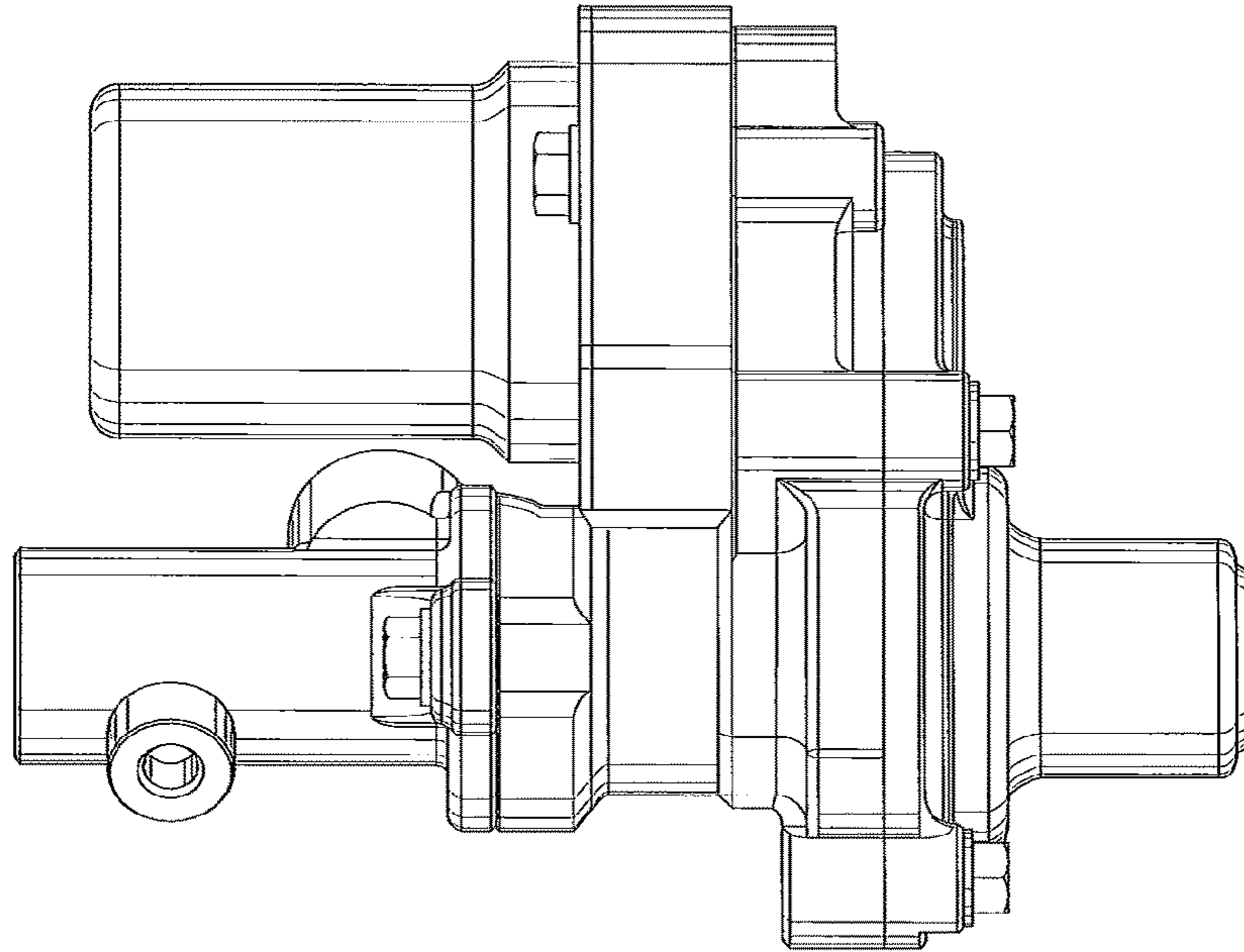

FIG.2

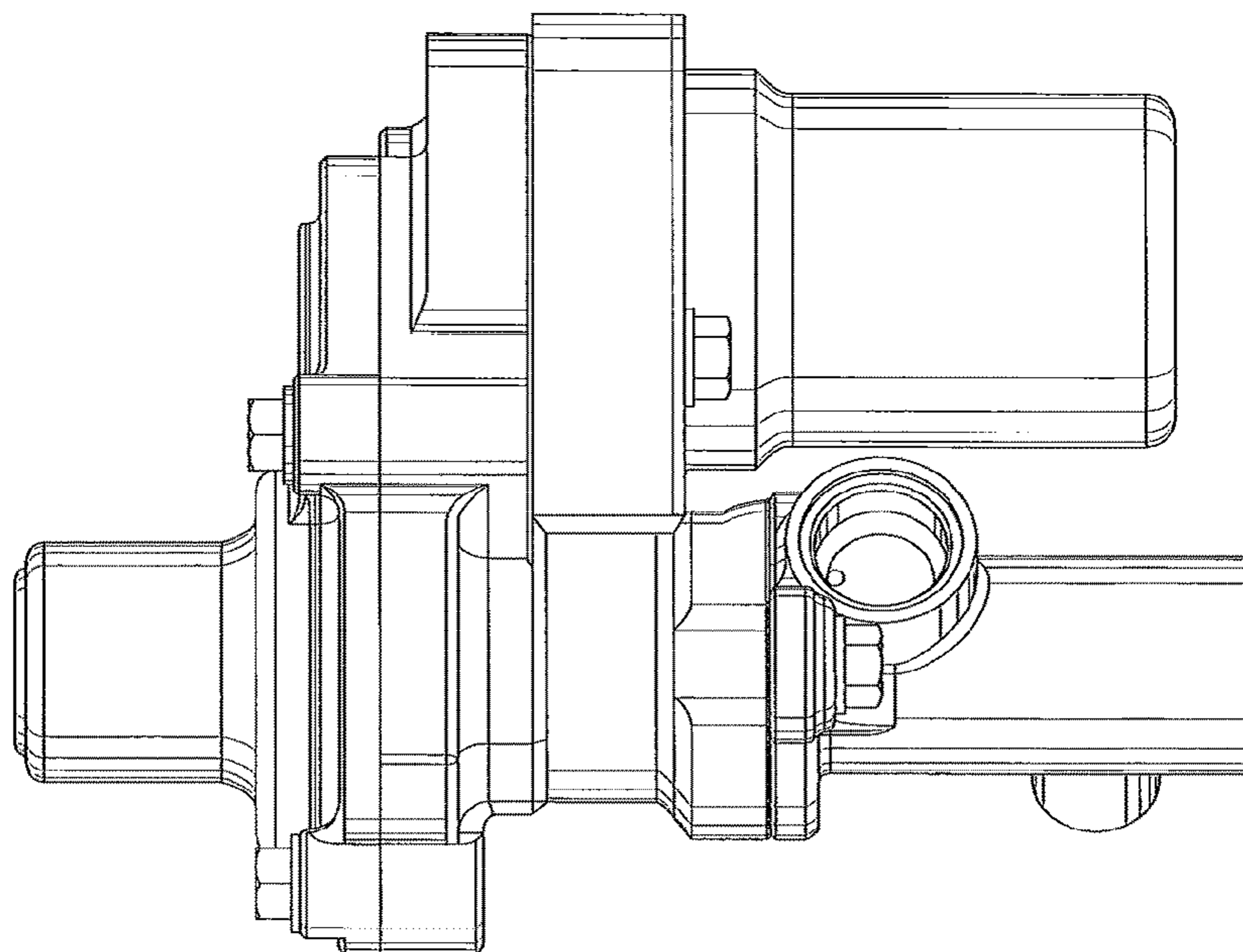

FIG.3

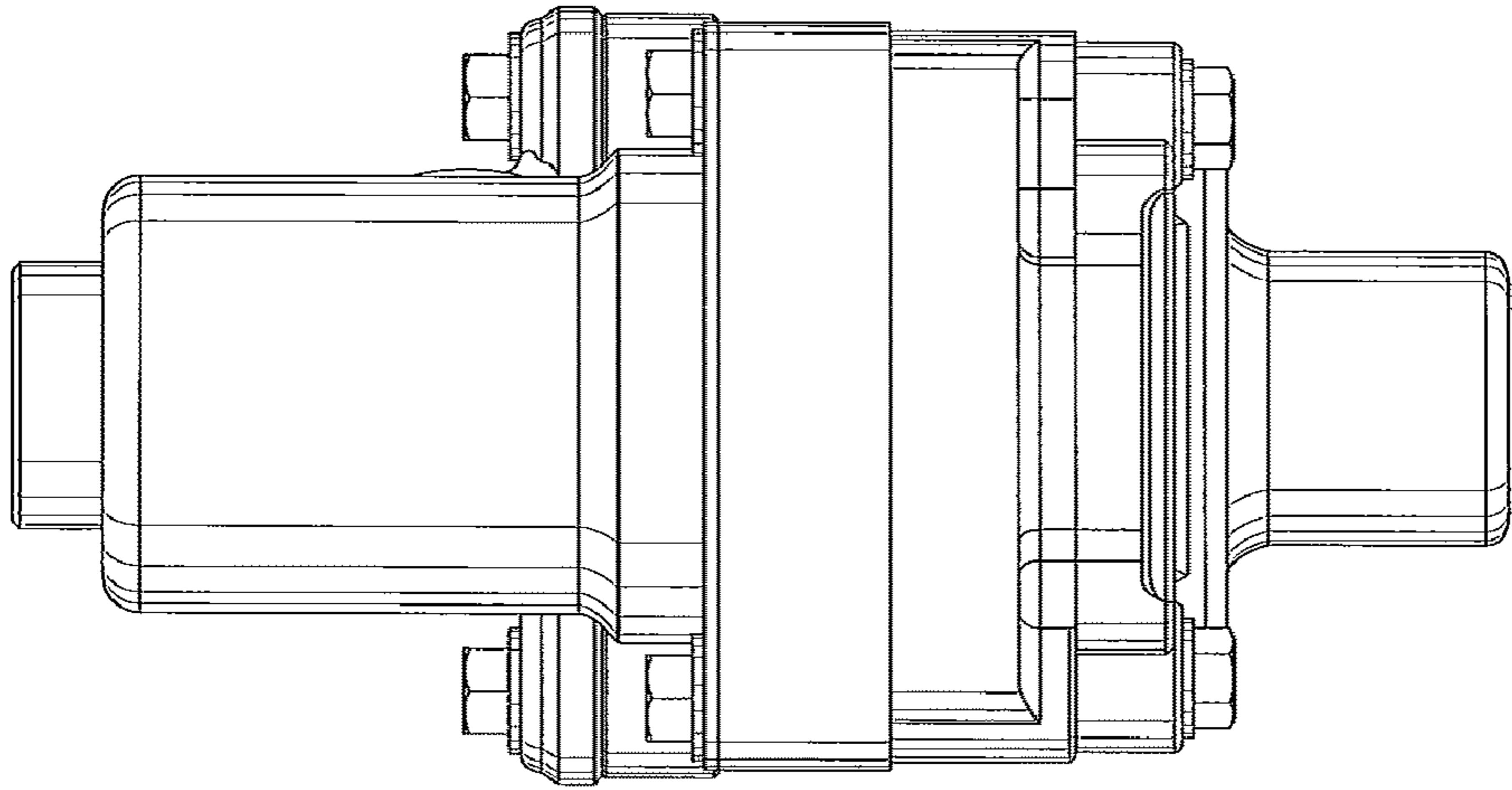

FIG.4

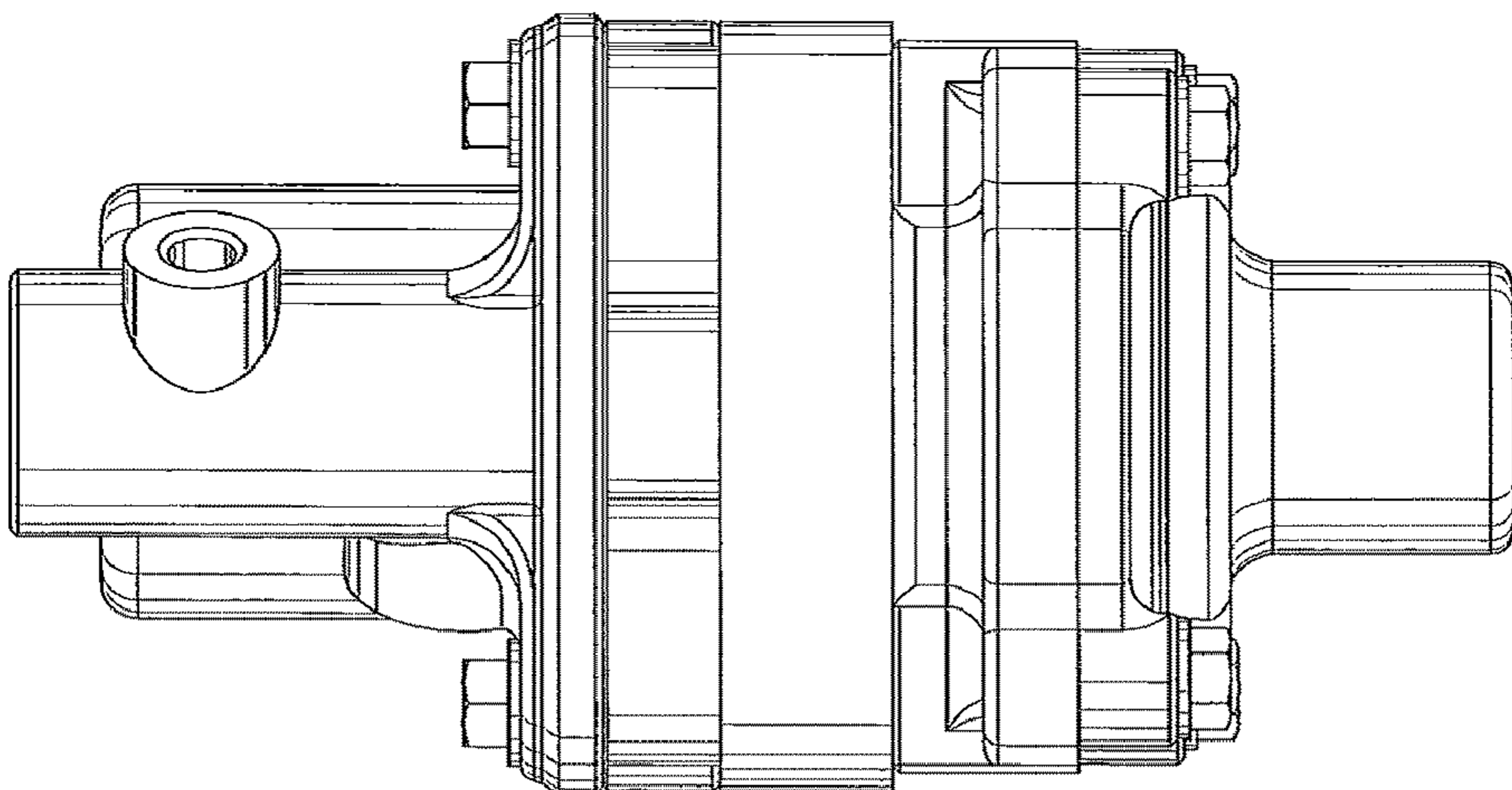

FIG.5

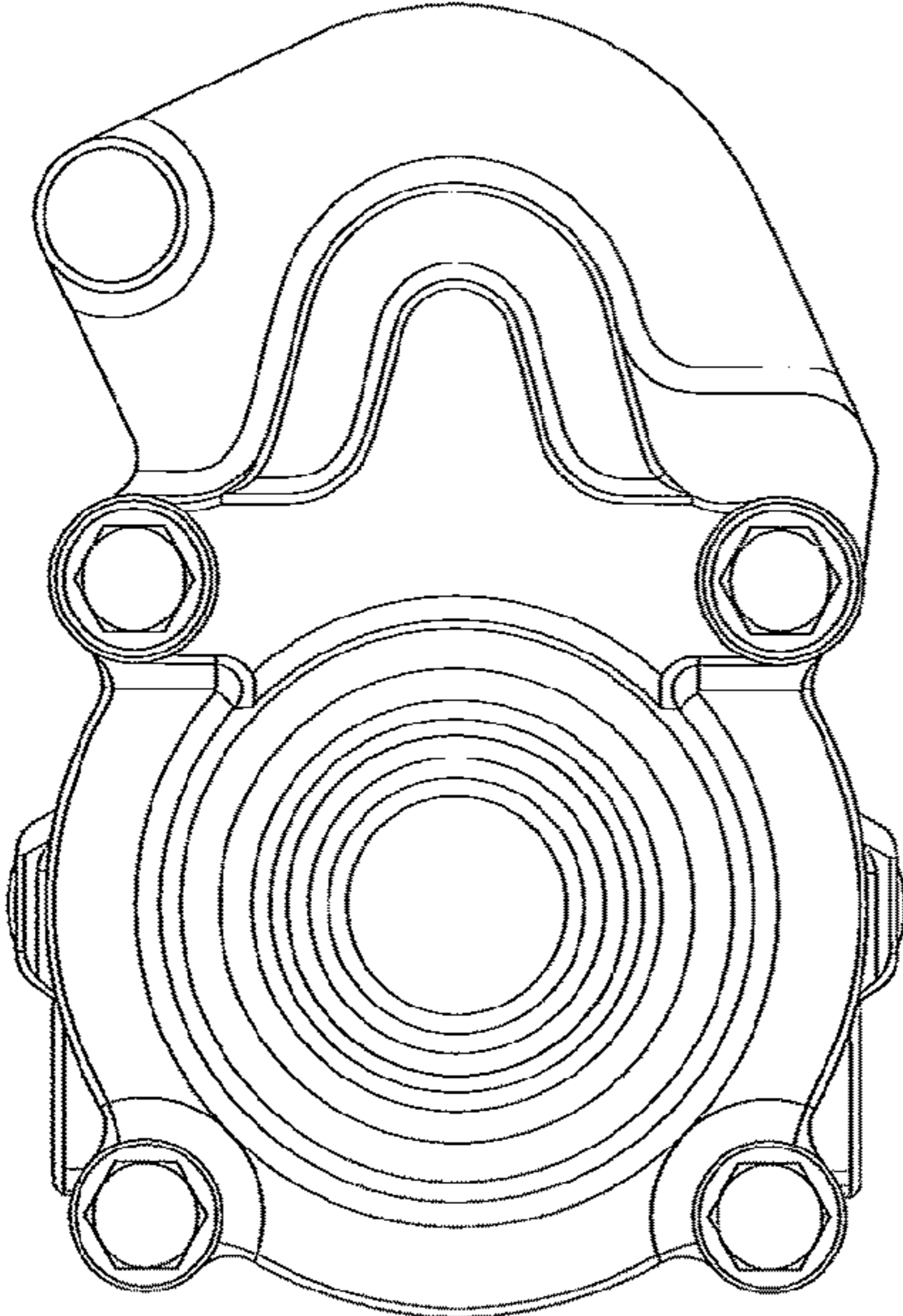

FIG.6

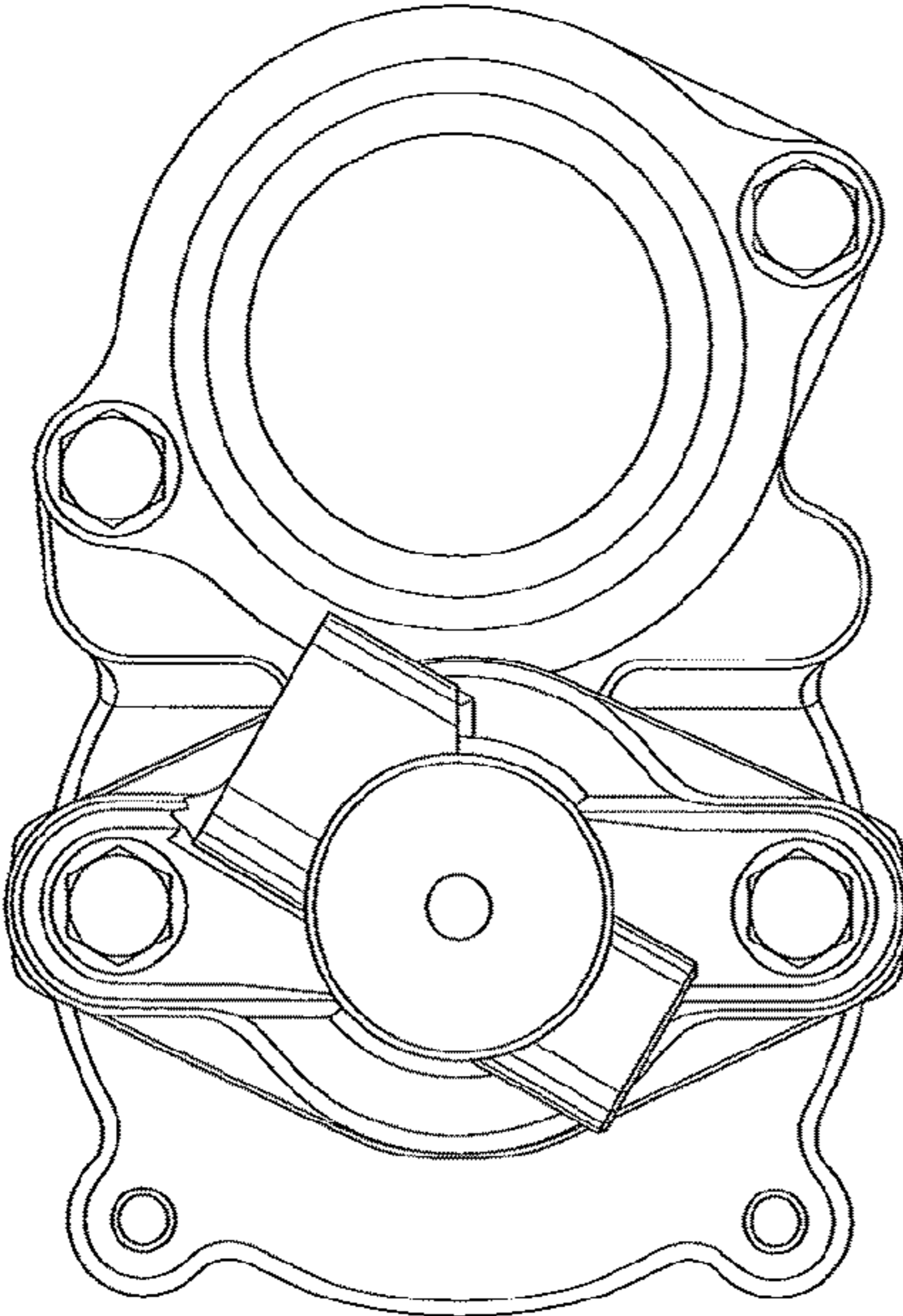

FIG.7

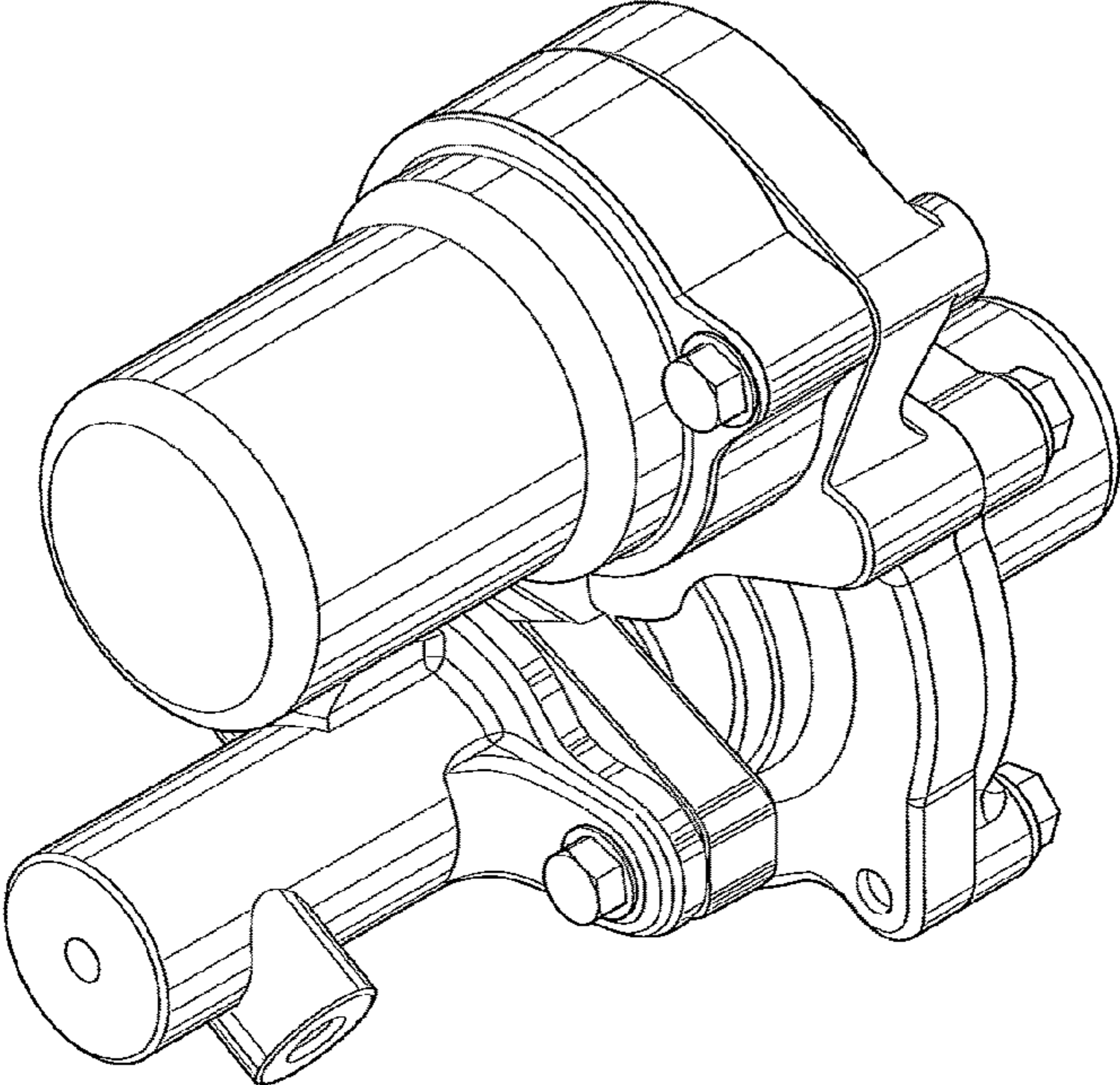

FIG.8

