



US00D652643S

(12) **United States Design Patent**
Porter et al.

(10) **Patent No.:** **US D652,643 S**
(45) **Date of Patent:** **** Jan. 24, 2012**

(54) **AIRCRAFT SEAT**

(75) Inventors: **Glen Wilson Porter**, Christchurch (NZ);
Victoria Anne Bamford, Auckland
(NZ); **Kerry Alan Reeves**, Auckland
(NZ); **Stuart Anthony Eric Hilton**,
Auckland (NZ)

(73) Assignee: **Air New Zealand Limited**, Auckland
(NZ)

(**) Term: **14 Years**

(21) Appl. No.: **29/387,186**

(22) Filed: **Mar. 10, 2011**

(30) **Foreign Application Priority Data**

Dec. 10, 2009	(NZ)	413078
Dec. 10, 2009	(NZ)	413079
Dec. 10, 2009	(NZ)	413080
Dec. 10, 2009	(NZ)	413081
Dec. 16, 2009	(NZ)	413107
Dec. 16, 2009	(NZ)	413108

(51) **LOC (9) Cl.** **06-01**

(52) **U.S. Cl.** **D6/356**

(58) **Field of Classification Search** D6/334-336,
D6/356, 367, 377, 381, 500-502; D12/195,
D12/345; 244/118.5-188.6, 122 R; 297/232,
297/342, 354.1, 361.1

See application file for complete search history.

(56) **References Cited**

U.S. PATENT DOCUMENTS

2,414,730	A	1/1947	Flogaus
2,947,349	A	8/1960	Kryter
4,936,620	A	6/1990	Francois et al.
5,992,798	A	11/1999	Ferry
6,059,364	A	5/2000	Dryburgh et al.
6,170,786	B1	1/2001	Park et al.
6,375,119	B2	4/2002	Park et al.
6,742,842	B2	6/2004	Dowty
6,793,282	B2	9/2004	Plant et al.

7,201,439	B2	4/2007	Schweizer
7,252,332	B2	8/2007	Thompson
7,448,575	B2	11/2008	Cheung et al.
7,469,861	B2	12/2008	Ferry et al.
7,472,957	B2	1/2009	Ferry et al.
7,523,888	B2	4/2009	Ferry et al.
7,578,470	B2	8/2009	Plant
2001/0003962	A1	6/2001	Park et al.
2001/0015566	A1	8/2001	Park et al.
2003/0184957	A1	10/2003	Stahl et al.
2004/0232283	A1	11/2004	Ferry et al.
2007/0080566	A1	4/2007	Ferry et al.
2007/0246981	A1	10/2007	Plant
2007/0295863	A1	12/2007	Thompson
2008/0042010	A1	2/2008	Watanabe
2009/0050740	A1	2/2009	Saint-Jalmes et al.
2009/0084897	A1	4/2009	Ferry et al.
2010/0065684	A1	3/2010	Ruiter et al.

FOREIGN PATENT DOCUMENTS

AU 2007201819 5/2007

(Continued)

Primary Examiner — Elizabeth Albert

Assistant Examiner — Kelley Donnelly

(74) *Attorney, Agent, or Firm* — Dann, Dorfmann, Herrell
and Skillman, P.C.

(57) **CLAIM**

We claim the ornamental design for an aircraft seat, as shown.

DESCRIPTION

FIG. 1 is a top plan view of a first embodiment of an aircraft seat embodying the design;
FIG. 2 is a left side view thereof;
FIG. 3 is a front perspective view thereof;
FIG. 4 is a rear view thereof;
FIG. 5 is a bottom front perspective view thereof;
FIG. 6 is a top plan view of a second embodiment of an aircraft seat embodying the design;
FIG. 7 is right side view thereof;
FIG. 8 is a front perspective view thereof;
FIG. 9 is a rear view thereof; and,
FIG. 10 is a bottom front perspective view thereof.

1 Claim, 10 Drawing Sheets

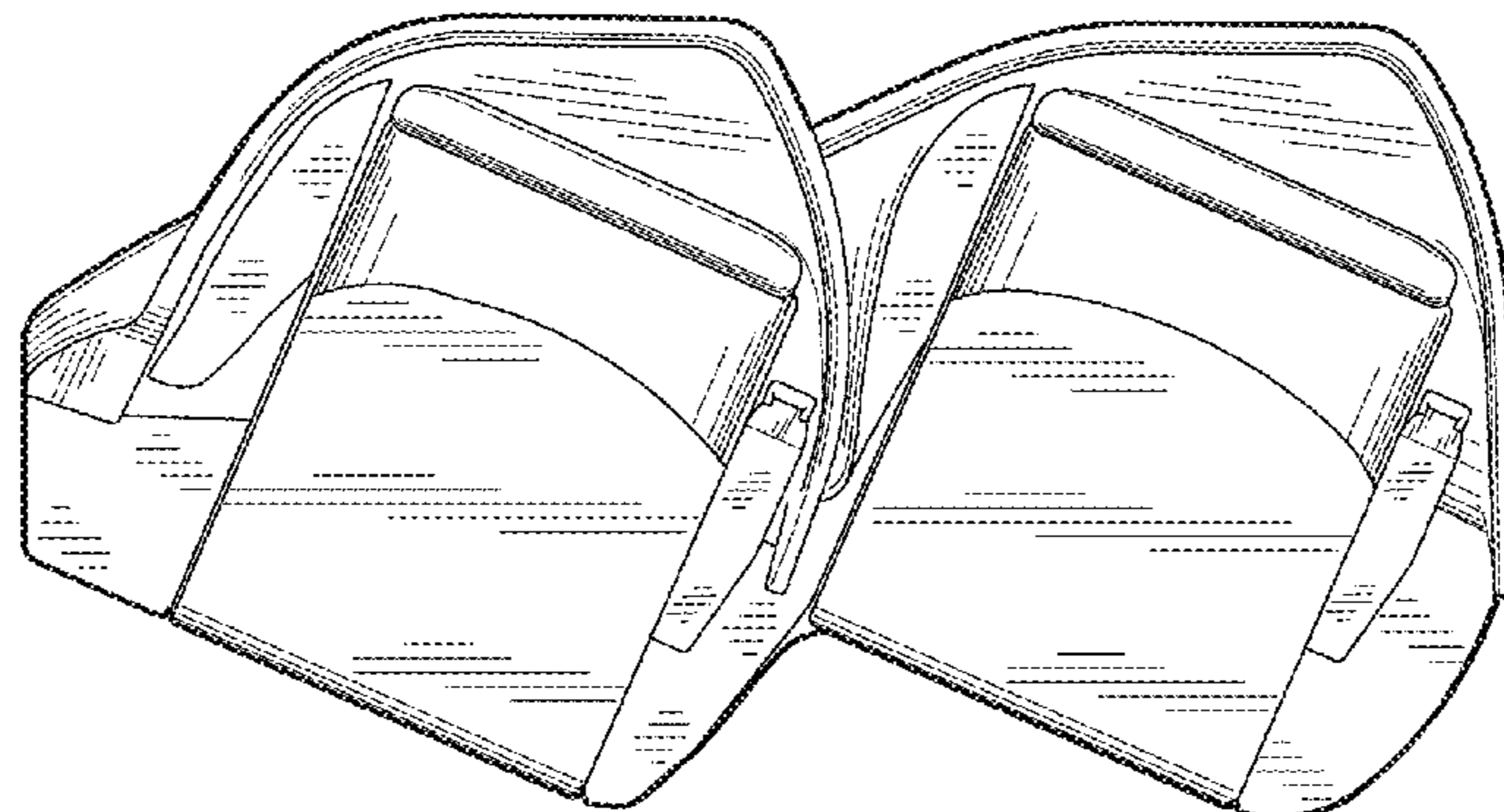

US D652,643 S

Page 2

FOREIGN PATENT DOCUMENTS					
CA	2625280	2/2003	EP	1417113	11/2005
DE	3436509	4/1986	EP	1495908	5/2007
DE	102006056898	6/2008	GB	2288728	11/1995
EP	0346299	12/1989	GB	2405791	3/2005
EP	0869060	10/1998	GB	2437164	10/2007
EP	0982226	1/2000	GB	2438162	11/2007
EP	0980825	2/2000	WO	0002745	1/2000
EP	0980826	2/2000	WO	03013903	2/2003
EP	1116654	7/2001	WO	2008072328	6/2008
			WO	2009073244	6/2009

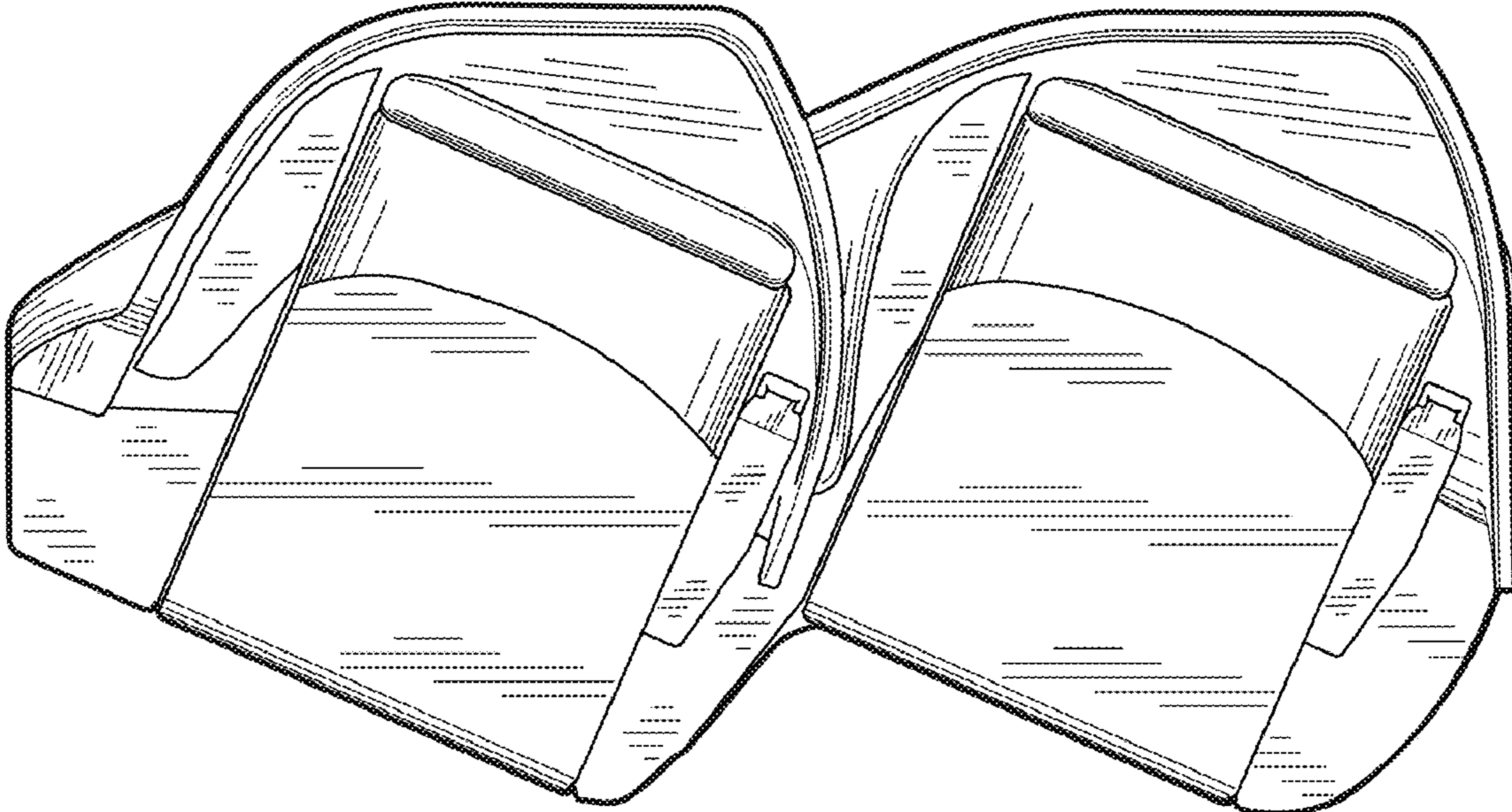

FIG. 1

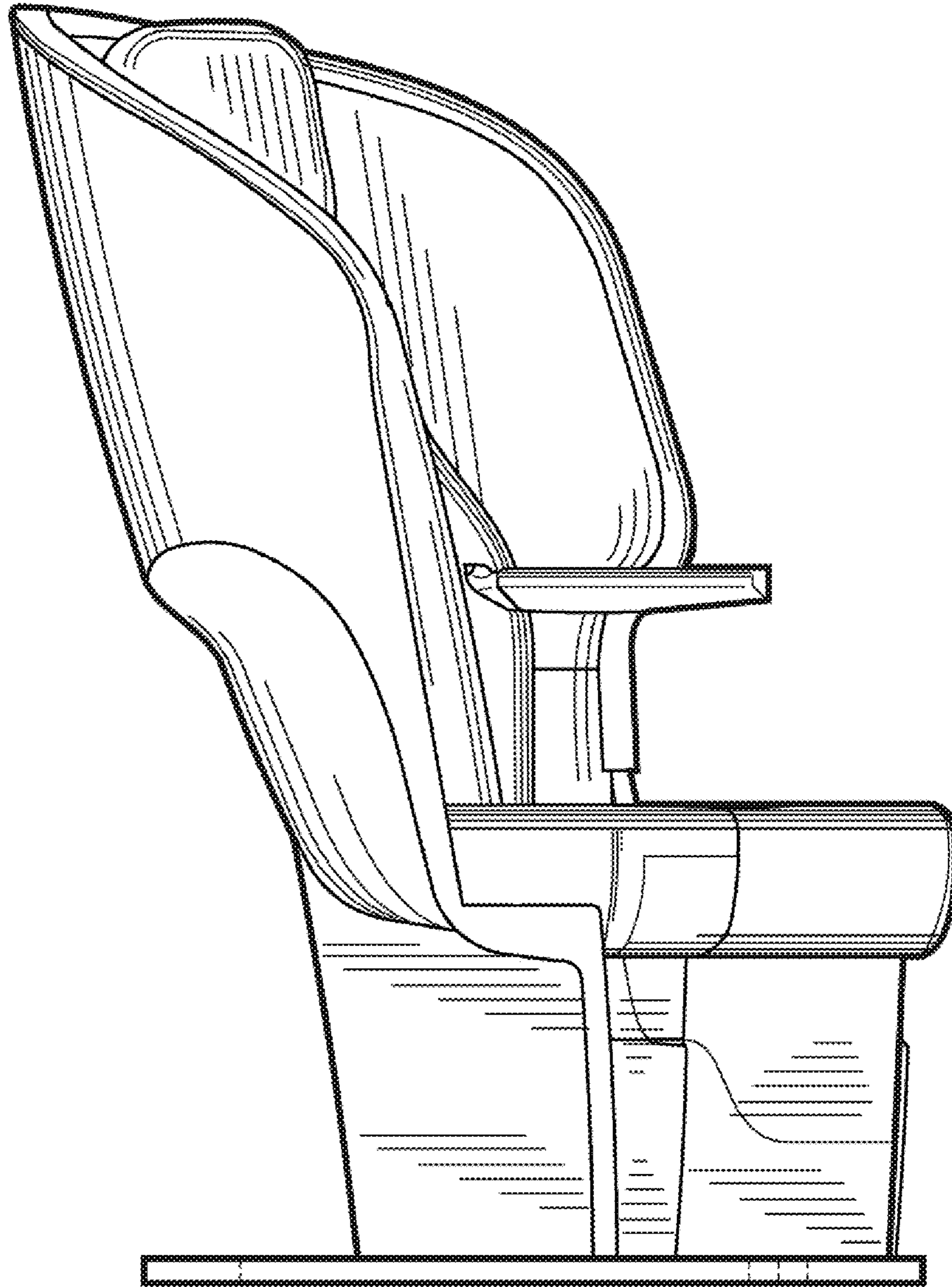

FIG. 2

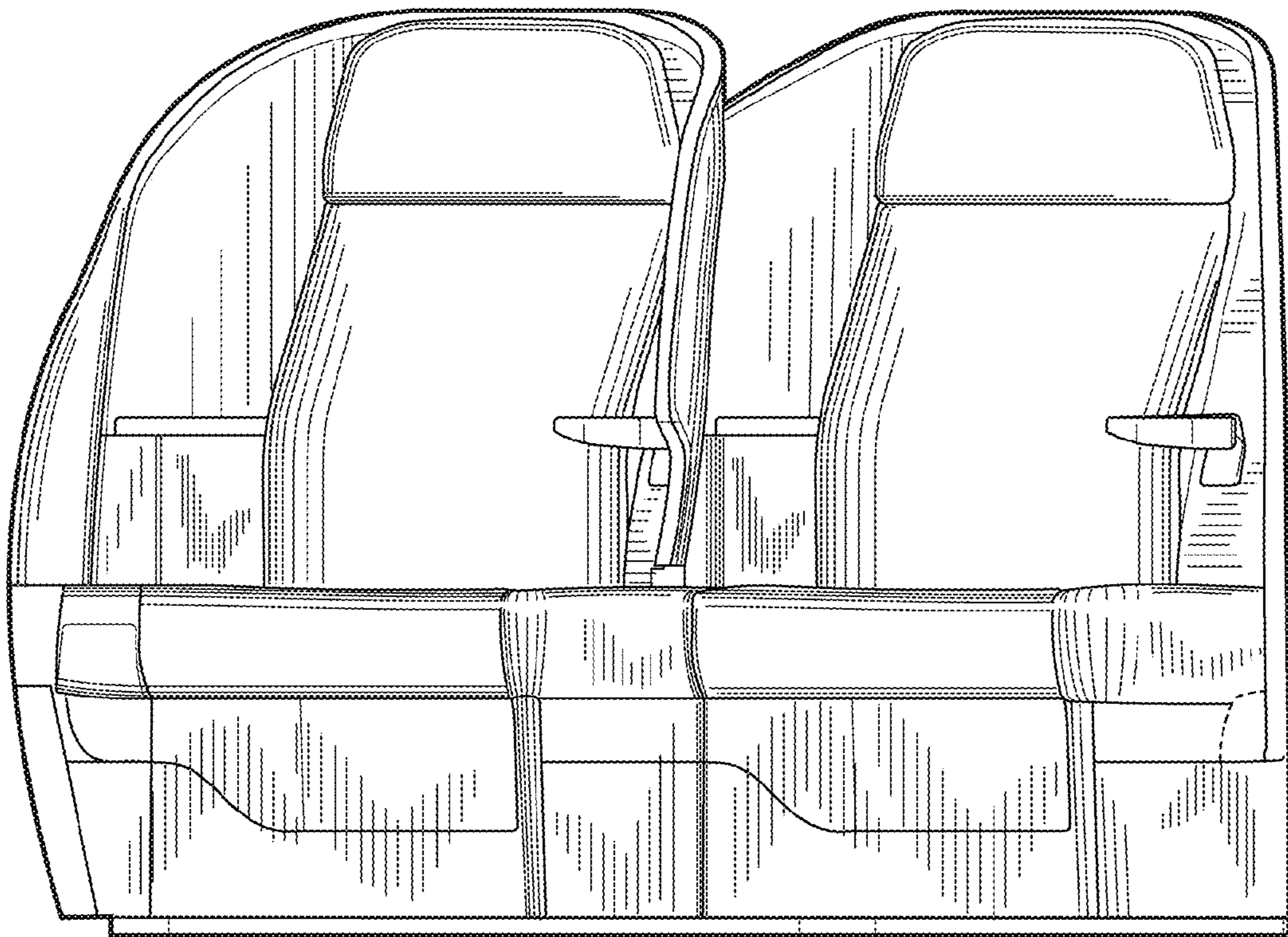

FIG. 3

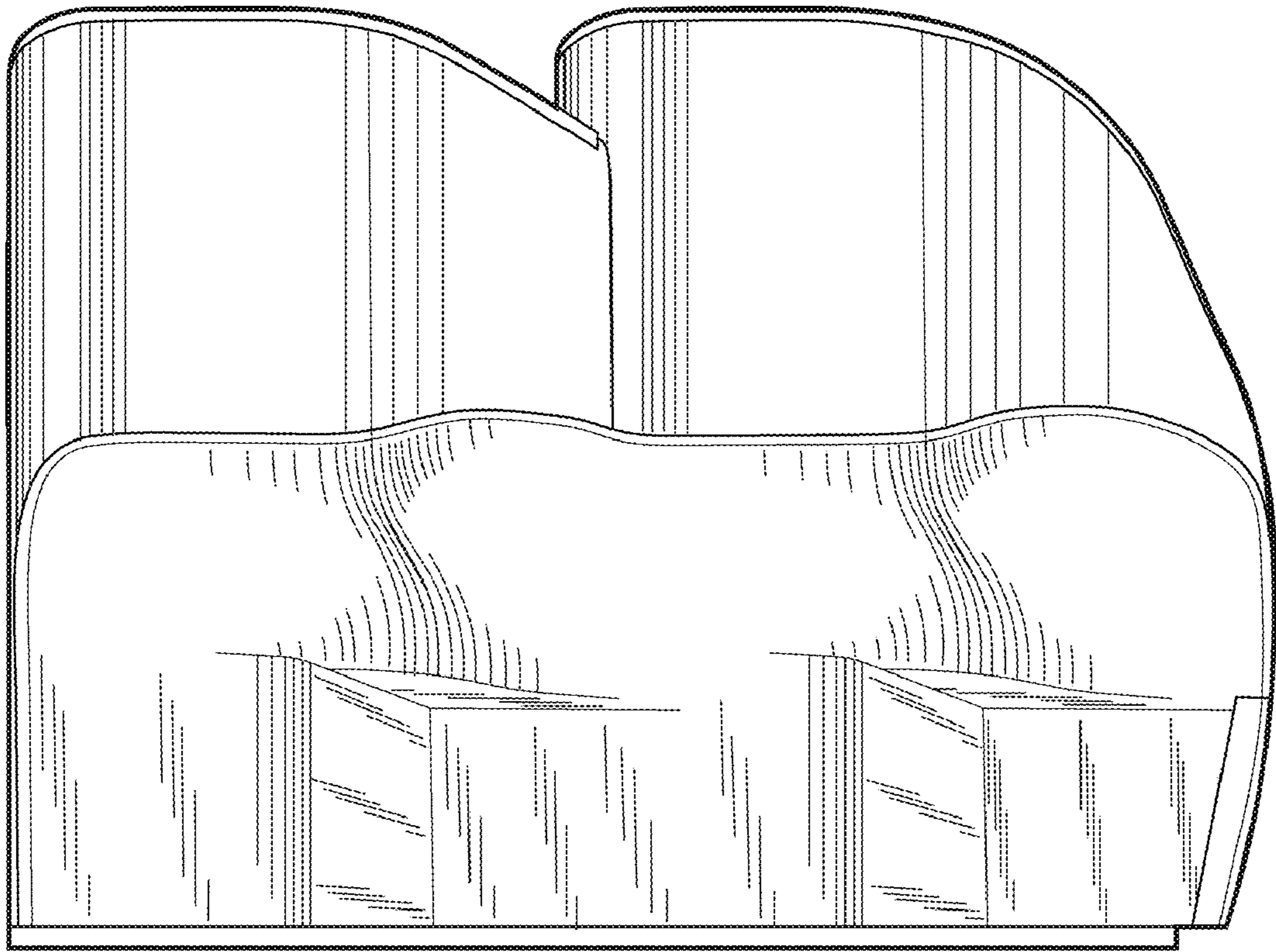

FIG. 4

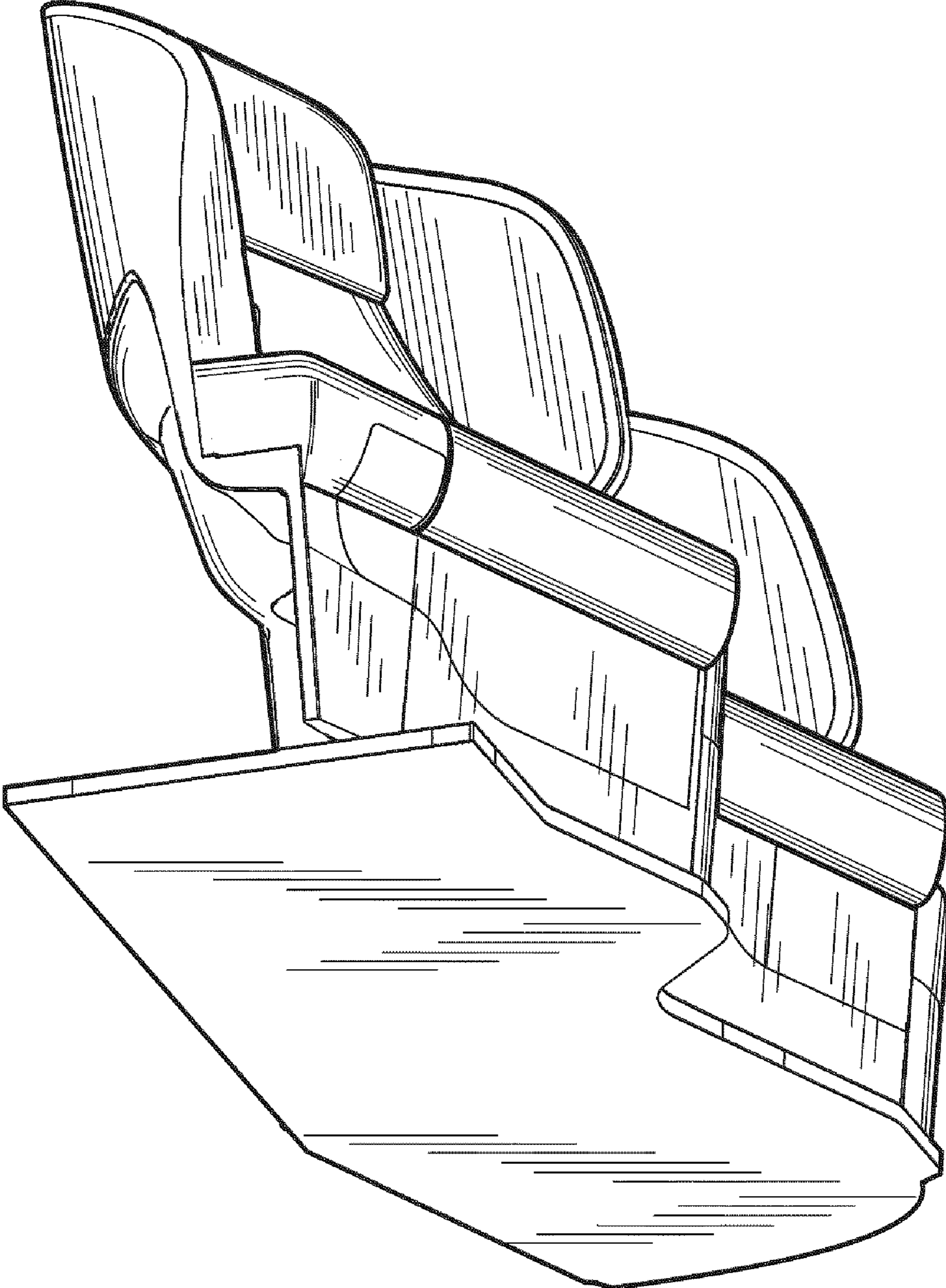

FIG. 5

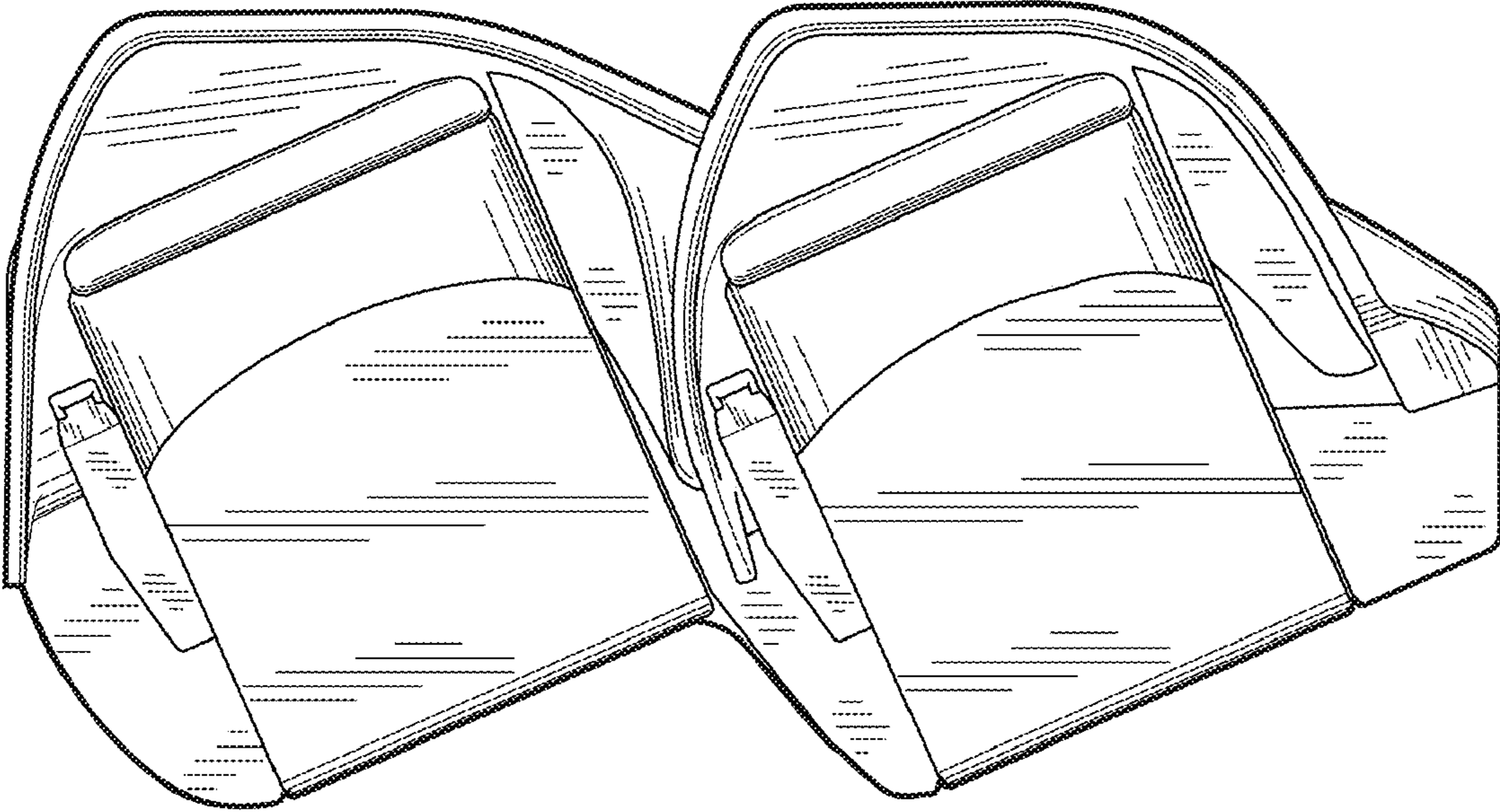

FIG. 6

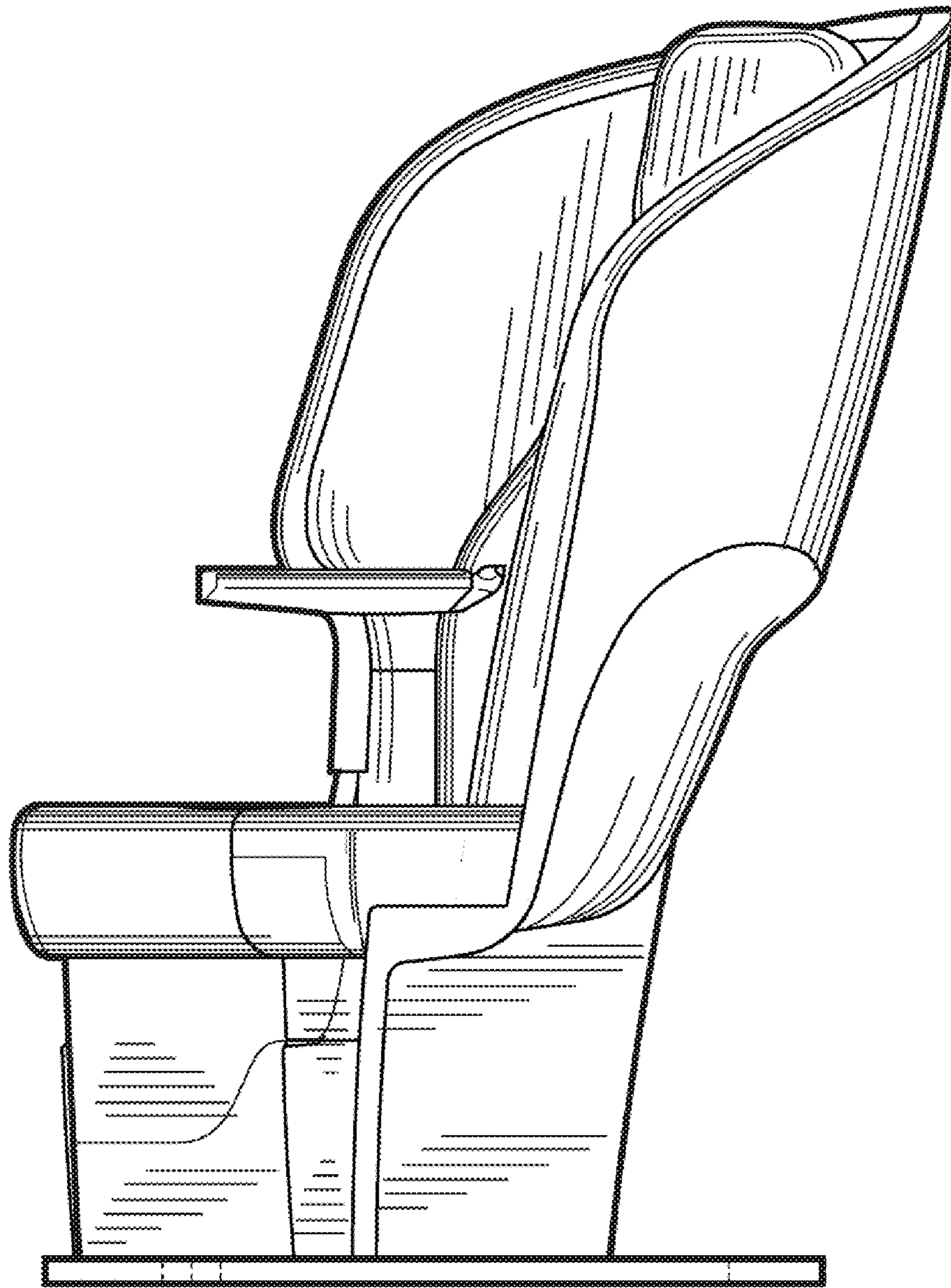

FIG. 7

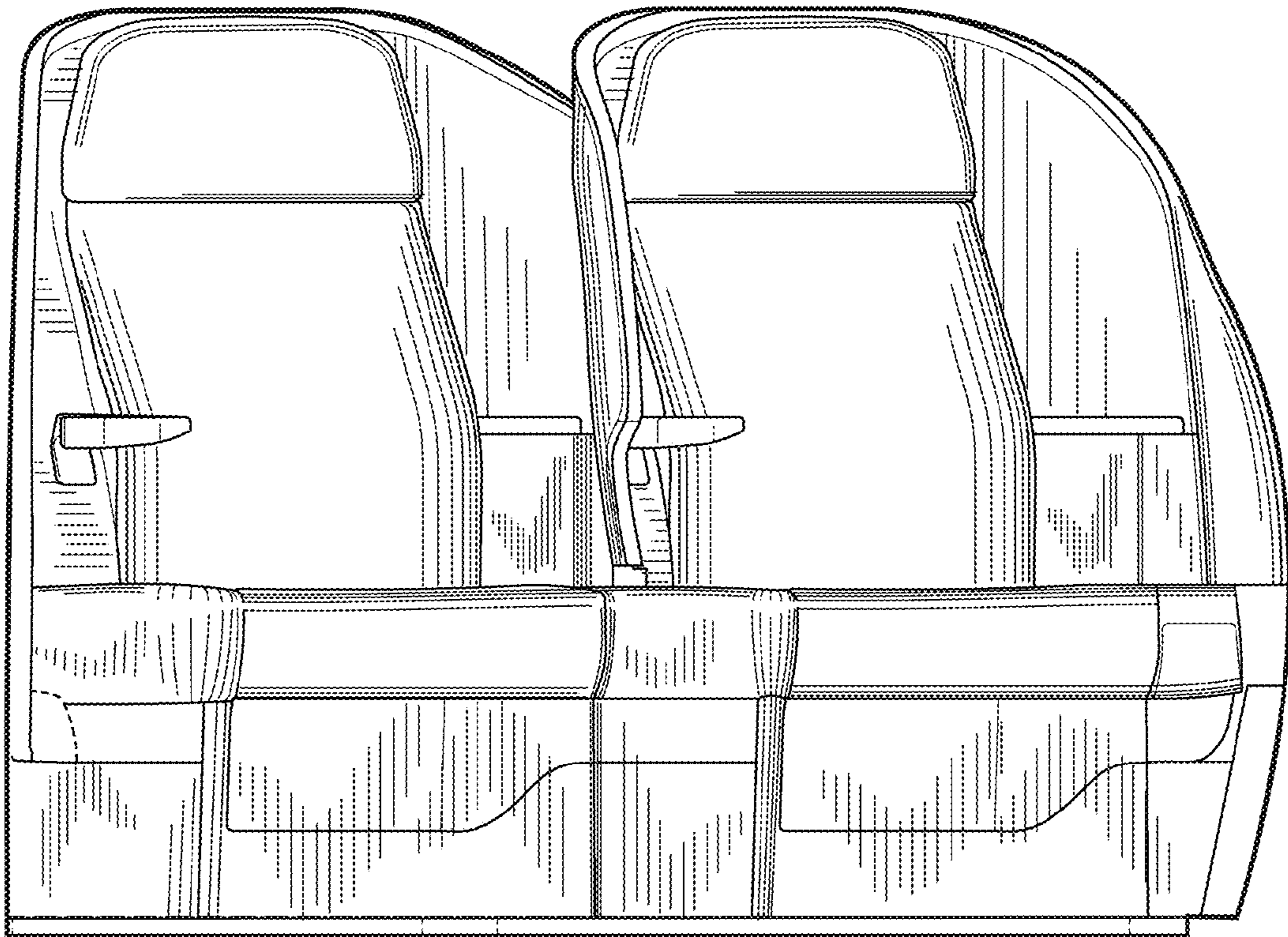

FIG. 8

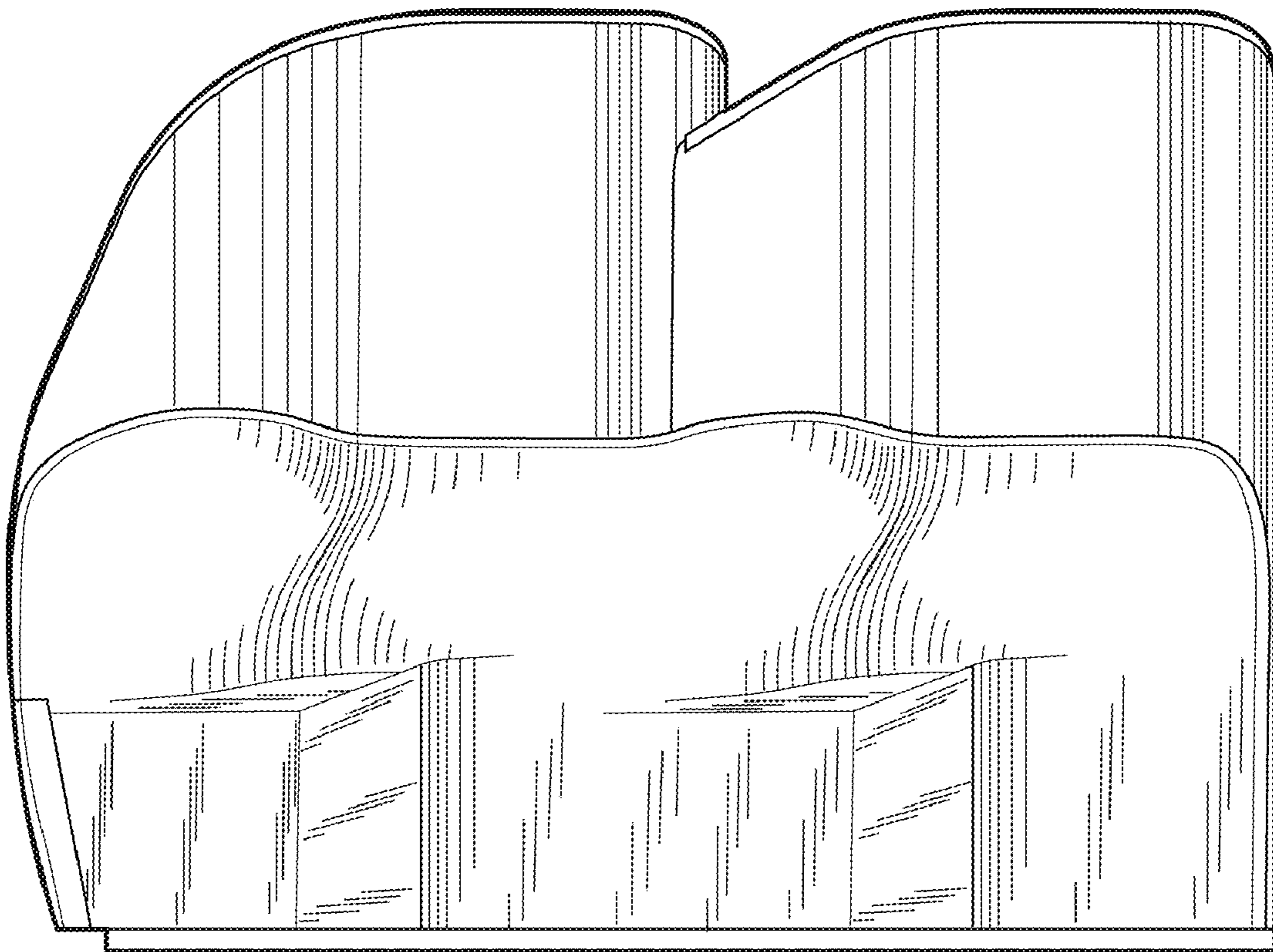

FIG. 9

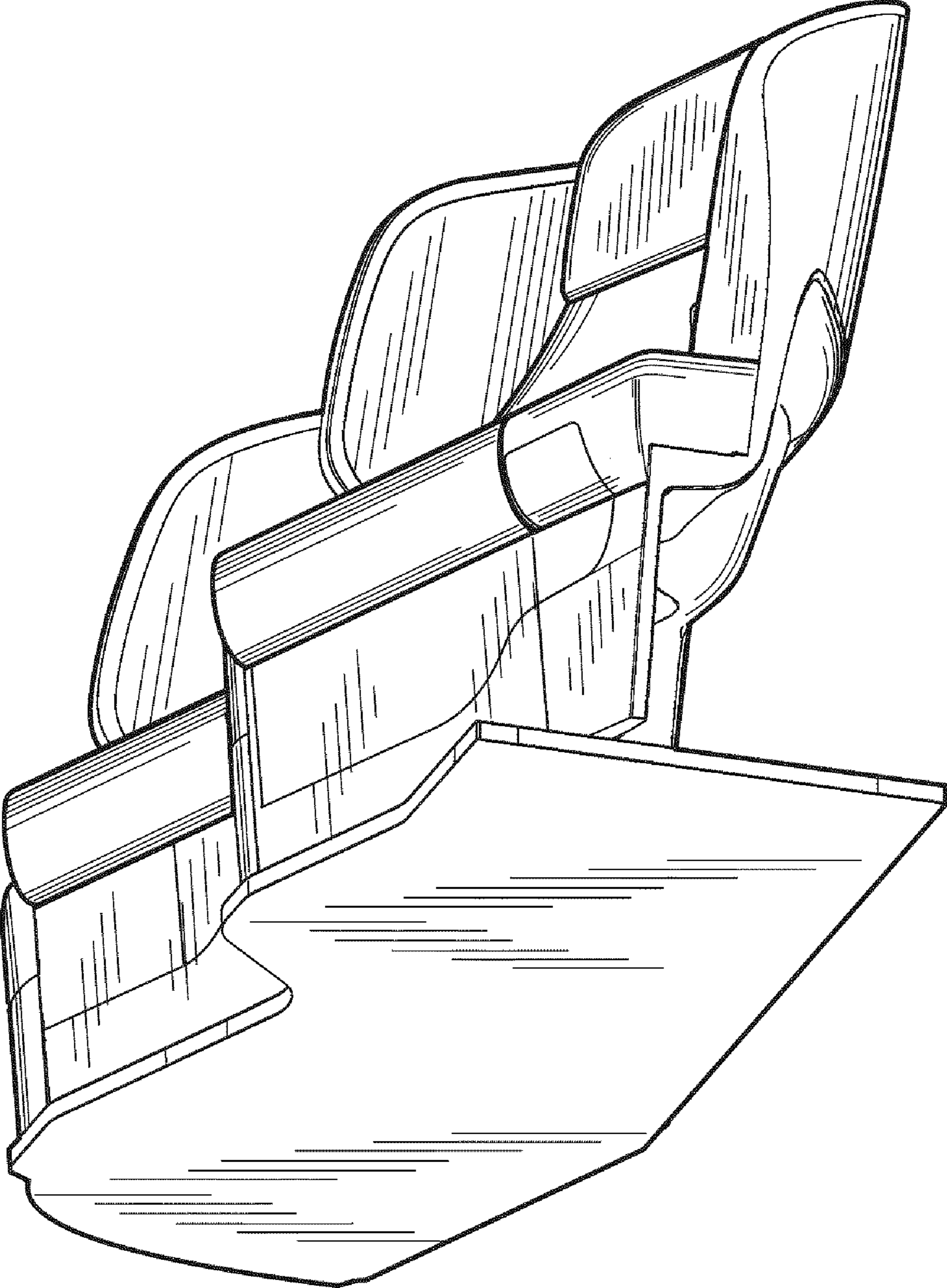

FIG. 10