



US00D652511S

(12) **United States Design Patent**
Lombardi, III et al.

(10) **Patent No.:** **US D652,511 S**
(45) **Date of Patent:** **** Jan. 17, 2012**

(54) **FEMALE BODY OF CONNECTOR FOR FLUID TUBING**

FOREIGN PATENT DOCUMENTS

DE 3439522 8/1985
(Continued)

(75) Inventors: **Francis J. Lombardi, III**, Loveland, CO (US); **Ravikumar Narayanan**, Fort Collins, CO (US); **Raymond L. Townsend**, Johnstown, CO (US)

OTHER PUBLICATIONS

About Us [online], Thuro Metal Products [retrieved on Apr. 9, 2010], retrieved from the Internet: <URL: <http://www.thurometal.com/about.html>>, 2 pages.

(73) Assignee: **Value Plastics, Inc.**, Fort Collins, CO (US)

(Continued)

(**) Term: **14 Years**

Primary Examiner — T. Chase Nelson

Assistant Examiner — Eric Goodman

(21) Appl. No.: **29/385,363**

(74) *Attorney, Agent, or Firm* — Dorsey & Whitney LLP

(22) Filed: **Feb. 11, 2011**

(57) **CLAIM**

We claim the ornamental design for a female body of a connector for fluid tubing, as shown and described.

(51) **LOC (9) Cl.** **24-02**

(52) **U.S. Cl.** **D24/129**

(58) **Field of Classification Search** D24/108–110.5, D24/127–130; 604/905, 533, 544, 408, 538, 604/43; 285/304–321

DESCRIPTION

See application file for complete search history.

This application is related to U.S. design patent application Ser. No. 29/385,357 filed Feb. 11, 2011 entitled “Connector for fluid tubing” and U.S. design patent application Ser. No. 29/385,360 filed Feb. 11, 2011 entitled “Male body of connector for fluid tubing.”

FIG. 1 is a top-left isometric view of a female body of a connector for fluid tubing.

FIG. 2 is a left side elevation view of the female body of FIG. 1.

FIG. 3 is a right side elevation view of the female body of FIG. 1.

FIG. 4 is a front elevation view of the female body of FIG. 1.

FIG. 5 is a rear elevation view of the female body of FIG. 1.

FIG. 6 is a top plan view of the female body of FIG. 1.

FIG. 7 is a bottom plan view of the female body of FIG. 1; and,

FIG. 8 is a cross-section view of the female body of FIG. 1 viewed along line 8-8 in FIG. 6.

(56) **References Cited**

U.S. PATENT DOCUMENTS

163,261	A	5/1875	Ruppenthal
185,896	A	1/1877	Curtis
187,982	A	3/1877	Pirsson et al.
200,944	A	3/1878	Smith
235,580	A	12/1880	Smith et al.
327,509	A	10/1885	Aldridge
584,008	A	6/1887	Munson
465,868	A	12/1891	List
725,421	A	4/1903	Dinkins
727,982	A	5/1903	Ludwig
874,957	A	12/1907	Godley
884,461	A	4/1908	Browne
909,131	A	1/1909	Antic

(Continued)

1 Claim, 5 Drawing Sheets

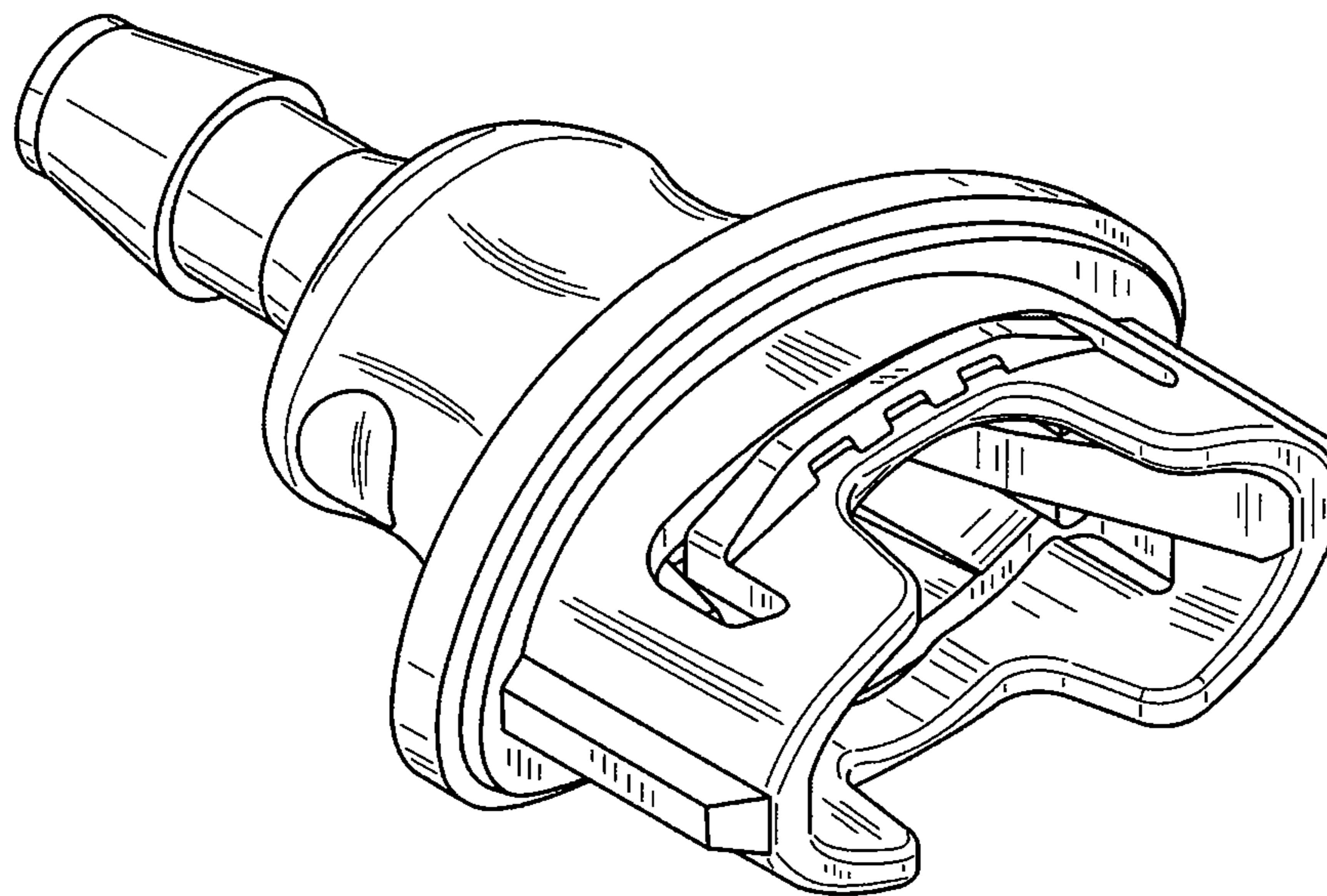

US D652,511 S

Page 2

U.S. PATENT DOCUMENTS							
951,889	A	3/1910	Teuer	3,314,696	A	4/1967	Ferguson et al.
1,029,819	A	6/1912	Nylander	3,317,214	A	5/1967	Durgom
1,033,187	A	7/1912	Metzger	D209,166	S	11/1967	Hunt
1,039,354	A	9/1912	Bonadio	D209,168	S	11/1967	Hunt
1,077,417	A	11/1913	McCracken	3,352,576	A	11/1967	Thomas
1,078,112	A	11/1913	Storm	3,382,892	A	5/1968	Cerbin
1,115,945	A	11/1914	Kunz	3,403,930	A	10/1968	Bernier
1,193,446	A	8/1916	Wells	3,432,176	A	3/1969	Valenziano
1,239,345	A	9/1917	Brown	3,448,760	A	6/1969	Cranage
1,255,847	A	2/1918	Arkin	3,450,424	A	6/1969	Calisher
1,259,684	A	3/1918	Vinten	3,512,808	A	5/1970	Graham
1,489,310	A	4/1924	Critchlow	3,523,701	A	8/1970	Graham
1,526,218	A	2/1925	Johnson	3,538,940	A	11/1970	Graham
1,578,504	A	3/1926	Bronson et al.	3,542,338	A	11/1970	Scaramucci
1,587,079	A	6/1926	Machino	3,545,490	A	12/1970	Burrus
1,767,073	A	6/1930	Ingold	3,550,626	A	12/1970	Daniels et al.
1,863,360	A	6/1932	Weatherhead	3,560,027	A	2/1971	Graham
1,950,947	A	3/1934	Mulroyan	3,563,265	A	2/1971	Graham
2,023,428	A	12/1935	Liebhardt	3,574,314	A	4/1971	Quercia
2,056,524	A	10/1936	Johnson	3,588,149	A	6/1971	Demler
2,066,473	A	1/1937	Jorgensen	3,596,933	A	8/1971	Luckenbill
2,097,628	A	11/1937	Liebhardt	3,599,843	A	8/1971	Johnston
2,099,335	A	11/1937	Hansen	3,600,917	A	8/1971	Krock
2,108,714	A	2/1938	Hirsch et al.	3,666,297	A	5/1972	Marks
2,116,705	A	5/1938	Marx et al.	3,690,336	A	9/1972	Drum
2,139,745	A	12/1938	Goodall	3,712,583	A	1/1973	Martindale et al.
2,147,355	A	2/1939	Scholtes	3,747,964	A	7/1973	Nilsen
2,159,116	A	5/1939	Zacharias	3,750,238	A	8/1973	Tanner
2,211,147	A	8/1940	Miller	3,815,887	A	6/1974	Curtis et al.
2,257,321	A	9/1941	Arnold	3,817,561	A	6/1974	Kay
2,263,293	A	11/1941	Ewald	3,829,135	A	8/1974	Forni
2,264,815	A	12/1941	Thomsen	3,876,234	A	4/1975	Harms
2,340,119	A	1/1944	Graham	3,889,710	A	6/1975	Brost
2,346,445	A	4/1944	Merker et al.	3,899,200	A	8/1975	Gamble
2,352,728	A	7/1944	Merker et al.	3,921,656	A	11/1975	Meisenheimer, Jr. et al.
2,429,782	A	10/1947	Versoy	3,979,934	A	9/1976	Isenmann
2,432,946	A	12/1947	Theunissen	3,990,674	A	11/1976	Schattenberg
2,470,800	A	5/1949	Ashton	4,025,049	A	5/1977	Schmidt
2,479,499	A	8/1949	Le Clair	4,039,213	A	8/1977	Walters
2,500,720	A	3/1950	Van der Heem	4,072,330	A	2/1978	Brysch
2,507,536	A	5/1950	Goodson	4,099,748	A	7/1978	Kavick
2,516,583	A	7/1950	Moore	4,113,627	A	9/1978	Leason
2,535,740	A	12/1950	Knopp	4,129,145	A	12/1978	Wynn
2,577,009	A	12/1951	Frantz	4,142,546	A	3/1979	Sandau
2,626,974	A	1/1953	Howard et al.	D252,470	S	7/1979	Pawlak
2,630,131	A	3/1953	Snyder	4,181,149	A	1/1980	Cox
2,661,018	A	12/1953	Snyder	4,182,519	A	1/1980	Wilson
2,701,147	A	2/1955	Summerville	D254,505	S	3/1980	Parsons et al.
2,722,399	A	11/1955	Oetiker	4,200,605	A	4/1980	Imamura
2,753,195	A	7/1956	Palmer	D255,145	S	5/1980	Nederman
2,774,616	A	12/1956	Dodd et al.	4,220,360	A	9/1980	Jacek et al.
2,790,571	A	4/1957	Flaith et al.	D258,526	S	3/1981	Nederman
2,864,628	A	12/1958	Edleson	4,253,687	A	3/1981	Maples
2,915,325	A	12/1959	Foster	D259,278	S	5/1981	McCaw
2,926,934	A	3/1960	Gill	4,271,865	A	6/1981	Galloway et al.
2,931,668	A	4/1960	Baley	4,282,175	A	8/1981	Volgstadt et al.
2,937,892	A	5/1960	Prescott, Jr.	4,287,644	A	9/1981	Durand
2,948,553	A	8/1960	Gill et al.	4,294,285	A	10/1981	Joslyn
2,967,067	A	1/1961	Singer	4,296,949	A	10/1981	Muetteties et al.
2,991,090	A	7/1961	De Cenzo	4,319,774	A	3/1982	Kavick
3,017,203	A	1/1962	Macleod	4,330,010	A	5/1982	Drescher et al.
3,037,497	A	6/1962	Roberson	4,330,142	A	5/1982	Paini
3,046,028	A	7/1962	Nathan	4,331,175	A	5/1982	Brake et al.
3,048,415	A	8/1962	Shook	4,331,177	A	5/1982	Makishima
3,073,342	A	1/1963	Magorien	4,340,200	A	7/1982	Stegmeier
3,078,068	A	2/1963	Romney	4,345,786	A	8/1982	Egert
D196,473	S	10/1963	Hill	4,346,703	A	8/1982	Dennehey
3,124,157	A	3/1964	Krzewina	4,351,351	A	9/1982	Flory et al.
3,129,020	A	4/1964	Bujnowski	4,366,816	A	1/1983	Bayard et al.
3,171,196	A	3/1965	Helitas	4,393,548	A	7/1983	Herb
3,191,628	A	6/1965	Kirkwood et al.	4,397,442	A	8/1983	Larkin
3,217,400	A	11/1965	Illesy et al.	4,407,526	A	10/1983	Cicenas
3,217,771	A	11/1965	Beall et al.	4,431,031	A	2/1984	Ettlinger
3,227,380	A	1/1966	Pinkston	4,431,218	A	2/1984	Paul
3,237,974	A	3/1966	Press	4,434,121	A	2/1984	Schaper
3,245,703	A	4/1966	Manly	4,436,125	A	3/1984	Blenkush
3,276,799	A	10/1966	Moore et al.	4,437,689	A	3/1984	Goebel et al.
3,279,497	A	10/1966	Norton et al.	4,439,188	A	3/1984	Dennehey
				4,458,719	A	7/1984	Strybel

US D652,511 S

4,489,914 A	12/1984	Stevenson et al.	5,123,677 A	6/1992	Kreczko et al.
4,489,961 A	12/1984	Laidig	5,143,381 A	9/1992	Temple
4,500,118 A	2/1985	Blenkush	5,160,177 A	11/1992	Washizu
4,527,745 A	7/1985	Butterfield et al.	5,160,474 A	11/1992	Huff
4,541,457 A	9/1985	Blenkush	5,165,733 A	11/1992	Sampson
4,541,657 A	9/1985	Smyth	5,169,161 A	12/1992	Jones
4,553,587 A	11/1985	Traylor	D332,482 S	1/1993	Petty et al.
D282,962 S	3/1986	Gerber	5,176,406 A	1/1993	Straghan
4,580,816 A	4/1986	Campbell et al.	5,181,752 A	1/1993	Benson et al.
4,603,888 A	8/1986	Goodall et al.	D333,178 S	2/1993	Novy
4,603,890 A	8/1986	Huppee	5,190,224 A	3/1993	Hamilton
4,613,112 A	9/1986	Philipot et al.	5,222,279 A	6/1993	Franco et al.
4,616,859 A	10/1986	Brunet	5,228,724 A	7/1993	Godeau
4,626,001 A	12/1986	Lee	5,232,020 A	8/1993	Mason et al.
4,632,436 A	12/1986	Kimura	D339,417 S	9/1993	Sampson et al.
4,635,972 A	1/1987	Lyll	5,251,025 A	10/1993	Cooper et al.
4,645,245 A	2/1987	Cunningham	5,273,053 A	12/1993	Pohndorf
4,658,326 A	4/1987	Clark et al.	5,297,826 A	3/1994	Percebois et al.
4,659,116 A	4/1987	Cameron	5,316,041 A	5/1994	Ramacier, Jr. et al.
4,694,544 A	9/1987	Chapman	5,318,332 A	6/1994	Hohmann et al.
4,699,298 A	10/1987	Grant et al.	5,330,235 A	7/1994	Wagner et al.
4,700,926 A	10/1987	Hansen	5,348,051 A	9/1994	Kallenbach
4,703,957 A	11/1987	Blenkush	5,348,354 A	9/1994	Badoureaux
4,706,847 A	11/1987	Sankey et al.	5,356,183 A	10/1994	Cole
4,712,280 A	12/1987	Fildan	5,374,088 A	12/1994	Moretti et al.
4,733,890 A	3/1988	Vyse	5,385,311 A	1/1995	Morikawa et al.
4,738,401 A	4/1988	Filicicchia	5,385,331 A	1/1995	Allread et al.
4,753,268 A	6/1988	Palau	D357,307 S	4/1995	Ramacier, Jr. et al.
4,768,558 A	9/1988	Weber	5,405,333 A	4/1995	Richmond
4,776,067 A	10/1988	Sorensen	5,405,339 A	4/1995	Kohnen et al.
4,790,567 A	12/1988	Kawano et al.	5,405,340 A	4/1995	Fageol et al.
4,790,569 A	12/1988	Chaffee	5,411,300 A	5/1995	Mitsui
4,792,115 A	12/1988	Jindra et al.	5,417,442 A	5/1995	Jornhagen
4,793,637 A	12/1988	Laipply et al.	5,421,622 A	6/1995	Godeau
D300,361 S	3/1989	Tokarz	5,437,650 A	8/1995	Larkin et al.
4,824,148 A	4/1989	Grabowski	5,462,313 A *	10/1995	Rea et al. 285/21.1
4,827,921 A	5/1989	Rugheimer	5,494,074 A *	2/1996	Ramacier, Jr. et al.
4,832,237 A	5/1989	Hurford, Jr.	D369,409 S *	4/1996	Salter D24/129
4,834,423 A	5/1989	DeLand	5,507,733 A	4/1996	Larkin et al.
4,844,512 A	7/1989	Gahwiler	5,511,527 A	4/1996	Lorraine et al.
4,863,201 A	9/1989	Carstens	D372,093 S	7/1996	Sampson et al.
4,863,202 A	9/1989	Oldford	5,536,258 A	7/1996	Folden
4,896,402 A	1/1990	Jansen et al.	5,542,712 A	8/1996	Klinger et al.
4,900,065 A	2/1990	Houck	5,547,166 A	8/1996	Engdahl
4,903,995 A	2/1990	Blenkush et al.	5,547,230 A	8/1996	Bank et al.
4,923,228 A	5/1990	Laipply et al.	5,553,895 A	9/1996	Karl et al.
4,928,999 A	5/1990	Landriault et al.	D375,160 S	10/1996	Sampson et al.
4,934,655 A	6/1990	Blenkush et al.	5,568,946 A	10/1996	Jackowski
4,935,992 A	6/1990	Due	5,595,217 A	1/1997	Gillen et al.
4,946,204 A	8/1990	Boticki	5,601,317 A	2/1997	Crouse et al.
4,949,745 A	8/1990	McKeon	5,607,190 A	3/1997	Exandier et al.
4,966,398 A	10/1990	Peterson	5,617,609 A	4/1997	Bently
4,969,879 A	11/1990	Lichte	5,620,025 A	4/1997	Lewin
D313,067 S	12/1990	Kotake et al.	5,628,726 A	5/1997	Cotter
D313,277 S	12/1990	Haining	D380,262 S	6/1997	Van Funderburk et al.
D314,050 S	1/1991	Sone	D382,639 S	8/1997	Musgrave et al.
D314,233 S	1/1991	Medvick	5,681,062 A	10/1997	Fukao et al.
4,982,736 A	1/1991	Schneider	5,682,662 A	11/1997	Coules et al.
4,991,880 A	2/1991	Bernart	5,683,117 A	11/1997	Corbett et al.
5,009,252 A	4/1991	Faughn	D387,147 S	12/1997	Vandermast et al.
5,015,014 A	5/1991	Sweeney	5,695,223 A	12/1997	Boticki
5,029,908 A	7/1991	Belisaire	D388,876 S	1/1998	Sampson
5,033,777 A	7/1991	Blenkush	5,709,244 A	1/1998	Patriquin et al.
D319,312 S	8/1991	Schneider	5,725,258 A	3/1998	Kujawski
5,052,725 A	10/1991	Meyer et al.	5,737,810 A	4/1998	Krauss
5,074,601 A	12/1991	Spors et al.	5,745,957 A	5/1998	Khokhar et al.
5,076,615 A	12/1991	Sampson	5,746,414 A	5/1998	Weldon et al.
5,078,429 A	1/1992	Braut et al.	5,762,646 A	6/1998	Cotter
5,085,472 A	2/1992	Guest	5,784,750 A	7/1998	Sankovic et al.
5,090,448 A	2/1992	Truchet	5,799,987 A	9/1998	Sampson
5,090,747 A	2/1992	Kotake	5,820,614 A	10/1998	Erskine et al.
5,094,482 A	3/1992	Petty et al.	5,837,180 A	11/1998	Linder et al.
5,104,158 A	4/1992	Meyer et al.	5,845,943 A	12/1998	Ramacier, Jr. et al.
5,106,127 A	4/1992	Briet	5,855,568 A	1/1999	Battiato et al.
D326,155 S	5/1992	Boehringer et al.	5,879,033 A	3/1999	Hansel et al.
5,110,163 A	5/1992	Benson et al.	5,882,047 A	3/1999	Ostrander et al.
5,112,084 A	5/1992	Washizu	5,884,531 A	3/1999	Koenig
5,114,250 A	5/1992	Usui	D407,803 S	4/1999	Redman
D326,715 S *	6/1992	Schmidt D24/164	5,897,142 A	4/1999	Kulevsky

US D652,511 S

5,911,367 A	6/1999	McInerney	D481,125 S	10/2003	Hayamizu	
5,911,403 A	6/1999	deCler et al.	6,641,177 B1	11/2003	Pinciario	
5,911,404 A	6/1999	Cheng	6,649,829 B2	11/2003	Garber et al.	
5,930,424 A	7/1999	Heimberger et al.	6,652,007 B1	11/2003	Hwang	
5,937,501 A	8/1999	Imgram	D484,241 S	12/2003	Peters et al.	
5,938,244 A	8/1999	Meyer	6,669,681 B2	12/2003	Jepson et al.	
5,941,577 A	8/1999	Musellec	6,676,172 B2	1/2004	Alksnis	
D413,967 S	9/1999	Yuen	D486,909 S	2/2004	Cise et al.	
5,957,898 A	9/1999	Jepson et al.	6,688,654 B2	2/2004	Romero	
5,961,157 A	10/1999	Baron et al.	6,692,038 B2	2/2004	Braun	
5,964,485 A	10/1999	Hame et al.	6,695,817 B1	2/2004	Fangrow	
5,965,077 A	10/1999	Rowley et al.	6,722,705 B2	4/2004	Korkor	
5,975,489 A	11/1999	deCler et al.	6,722,708 B2	4/2004	Morohoshi et al.	
5,984,378 A	11/1999	Ostrander et al.	6,762,365 B2	7/2004	Inoue et al.	
5,988,704 A	11/1999	Ryhman	6,767,017 B2	7/2004	Crapart et al.	
6,012,743 A	1/2000	Godeau et al.	D495,050 S	8/2004	Guala	
6,015,171 A	1/2000	Schorn	6,783,520 B1	8/2004	Candray et al.	
D419,861 S	2/2000	Khokhar	D497,428 S	10/2004	Hayamizu	
6,019,348 A	2/2000	Powell	6,799,747 B1	10/2004	Lai	
6,024,124 A	2/2000	Braun et al.	D498,533 S	11/2004	Hayamizu	
6,029,701 A	2/2000	Chaffardon et al.	6,814,726 B1	11/2004	Lauer	
6,032,691 A	3/2000	Powell et al.	6,840,277 B1	1/2005	Nimberger	
6,041,805 A	3/2000	Gydesen et al.	6,846,021 B2	1/2005	Rohde et al.	
D422,487 S	4/2000	Khokhar	6,848,723 B2	2/2005	Lamich	
6,050,297 A	4/2000	Ostrowski et al.	6,863,314 B2	3/2005	Guest	
6,076,234 A	6/2000	Khokhar et al.	6,871,878 B2	3/2005	Miros	
6,077,245 A	6/2000	Heinrich et al.	D503,778 S	4/2005	Wicks	
6,077,259 A	6/2000	Caizza et al.	6,886,803 B2	5/2005	Mikiya et al.	
6,082,401 A	7/2000	Braun et al.	6,897,374 B2	5/2005	Garber et al.	
6,086,044 A	7/2000	Guest	6,899,315 B2	5/2005	Maiville et al.	
6,089,540 A	7/2000	Heinrichs et al.	D507,647 S	7/2005	Beck et al.	
6,099,045 A	8/2000	Pirona	6,916,007 B2	7/2005	deCler et al.	
6,112,855 A	9/2000	Camacho et al.	6,916,050 B2	7/2005	Milhas	
6,123,690 A	9/2000	Mejslov	6,926,311 B2 *	8/2005	Chang et al.	285/317
6,135,150 A	10/2000	Powell et al.	6,929,246 B2	8/2005	Arzenton et al.	
6,135,992 A	10/2000	Wang	6,945,273 B2	9/2005	Reid	
6,142,538 A	11/2000	Volgstadt et al.	6,949,084 B2	9/2005	Marggi et al.	
6,145,896 A	11/2000	Vitel et al.	6,981,547 B2 *	1/2006	Maguire et al.	166/242.7
6,152,914 A	11/2000	Van De Kerkhof et al.	6,997,486 B2	2/2006	Milhas	
6,155,610 A	12/2000	Godeau et al.	6,997,919 B2	2/2006	Olsen et al.	
6,161,578 A	12/2000	Braun et al.	7,005,581 B2	2/2006	Burnette	
6,176,523 B1	1/2001	Winslett	7,011,342 B2	3/2006	Guivarc'h et al.	
6,182,694 B1	2/2001	Sievers et al.	7,014,214 B2	3/2006	Kaneko	
6,189,560 B1	2/2001	Reynolds	D522,109 S	5/2006	White et al.	
6,199,915 B1	3/2001	Becker	7,044,161 B2	5/2006	Tiberghien	
6,199,919 B1	3/2001	Kawasaki et al.	7,044,506 B2	5/2006	Dong	
6,199,920 B1	3/2001	Neustadtl	D523,553 S	6/2006	Beck et al.	
6,221,064 B1	4/2001	Nadal	7,081,223 B2	7/2006	Khoury	
6,231,089 B1	5/2001	DeCler et al.	7,108,297 B2	9/2006	Takayanagi et al.	
D444,054 S	6/2001	Bernard et al.	7,118,138 B1	10/2006	Rowley et al.	
6,250,688 B1	6/2001	Kirby	7,128,348 B2	10/2006	Kawamura et al.	
6,257,626 B1	7/2001	Campau	7,137,654 B2	11/2006	Segal et al.	
6,260,851 B1	7/2001	Baron	7,140,592 B2	11/2006	Phillips	
6,261,282 B1	7/2001	Jepson et al.	7,147,252 B2	12/2006	Teuscher et al.	
6,293,596 B1	9/2001	Kinder	7,150,478 B2	12/2006	Poirier et al.	
6,296,796 B1	10/2001	Gordon	7,153,296 B2	12/2006	Mitchell	
6,302,147 B1	10/2001	Rose et al.	D540,944 S	4/2007	Guala	
6,318,764 B1	11/2001	Trede et al.	7,210,917 B2	5/2007	Lai et al.	
6,344,033 B1	2/2002	Jepson et al.	D547,446 S *	7/2007	Racz et al.	D24/129
D459,206 S	6/2002	Caveney et al.	D550,355 S	9/2007	Racz et al.	
6,402,207 B1	6/2002	Segal et al.	D557,409 S	12/2007	Veliss et al.	
6,422,574 B1	7/2002	Mooklar	7,316,428 B2 *	1/2008	Takayanagi et al.	285/319
6,423,053 B1	7/2002	Lee	D564,660 S	3/2008	Hayashi	
6,439,620 B1	8/2002	Guest	7,343,931 B2	3/2008	Packham	
6,454,314 B1	9/2002	Grosspietsch et al.	D567,340 S	4/2008	Tiberghien	
6,481,758 B1	11/2002	Andre et al.	D569,507 S *	5/2008	Blanchard	D24/130
6,481,759 B1	11/2002	Kawasaki et al.	D569,955 S	5/2008	Chen	
6,485,064 B1	11/2002	Davidson	7,377,553 B2	5/2008	Takayanagi	
6,485,483 B1	11/2002	Fujii	D570,457 S	6/2008	Brown	
6,505,866 B1	1/2003	Nakamura et al.	7,390,029 B2	6/2008	Matsubara	
6,508,807 B1	1/2003	Peters	7,434,842 B2	10/2008	Schmidt	
6,520,546 B2	2/2003	Szabo	7,434,846 B2	10/2008	Baumgartner	
D471,261 S	3/2003	Kozu	7,448,653 B2	11/2008	Jensen et al.	
6,540,263 B1	4/2003	Sausner	7,464,970 B2	12/2008	Yamada et al.	
6,543,745 B1	4/2003	Enerson	7,467,813 B2	12/2008	Gunderson	
6,595,964 B2	7/2003	Finley et al.	7,469,472 B2	12/2008	DeCler et al.	
6,609,696 B2	8/2003	Enerson	7,478,840 B2	1/2009	Youssefifar	
6,612,634 B1	9/2003	Zoppas	7,494,156 B2	2/2009	Okada	
6,626,465 B2	9/2003	Lacroix et al.	7,503,595 B2	3/2009	McKay	

US D652,511 S

Page 5

7,516,990	B2	4/2009	Jamison et al.	2008/0287920	A1	11/2008	Fangrow et al.
7,547,047	B2	6/2009	deCler et al.	2009/0079187	A1	3/2009	Malone
D595,845	S	7/2009	Mros et al.	2009/0127847	A1	5/2009	Hagen et al.
D595,846	S	7/2009	Racz et al.	2009/0129047	A1	5/2009	Park et al.
D596,288	S *	7/2009	Racz et al. D24/129	2009/0140519	A1	6/2009	Pavnaskar et al.
D596,739	S	7/2009	Ng et al.	2009/0167018	A1	7/2009	Lien
7,562,906	B2	7/2009	Schmidt	2009/0187166	A1	7/2009	Young
7,566,077	B2	7/2009	Tsurumi	2009/0188575	A1	7/2009	Williams et al.
7,581,763	B2	9/2009	Salomon-Bahls	2010/0001516	A1*	1/2010	Pisula et al. 285/311
D602,128	S *	10/2009	Williams et al. D23/262	2010/0056975	A1	3/2010	Dale et al.
7,614,666	B2	11/2009	Eggert et al.	2010/0078934	A1*	4/2010	Matsunaga 285/316
7,647,954	B2	1/2010	Garber et al.	2010/0185040	A1	7/2010	Uber et al.
7,666,178	B2	2/2010	McMichael	2010/0194100	A1	8/2010	Koch
D612,021	S	3/2010	Schmidt	2010/0276922	A1	11/2010	Rehder et al.
7,677,608	B2	3/2010	Takayanagi	2010/0295295	A1	11/2010	Schmidt
D613,853	S	4/2010	Ng et al.	2010/0301599	A1	12/2010	Jensen et al.
7,695,020	B2	4/2010	Schmidt	2010/0319796	A1	12/2010	Whitaker
7,731,244	B2	6/2010	Miros et al.	2011/0012340	A1	1/2011	Packham et al.
D619,706	S	7/2010	Schon et al.	2011/0204621	A1*	8/2011	Whitaker et al. 285/305
7,770,939	B2	8/2010	Jensen et al.				
7,806,139	B2	10/2010	Packham et al.				
D629,894	S	12/2010	Lombardi, III et al.				
7,849,877	B2	12/2010	Tan et al.				
D630,320	S	1/2011	Lombardi, III et al.				
D632,783	S *	2/2011	Maesarapu D24/129				
7,878,553	B2	2/2011	Wicks et al.				
D634,840	S	3/2011	Lombardi, III et al.				
7,976,071	B2*	7/2011	Bibby 285/308				
2001/0017466	A1	8/2001	Braun				
2002/0022762	A1	2/2002	Beane et al.				
2002/0093192	A1	7/2002	Matkovich				
2002/0140172	A1	10/2002	Platusich				
2002/0156344	A1	10/2002	Pasricha et al.				
2002/0185861	A1	12/2002	Inoue				
2003/0004397	A1	1/2003	Kameya et al.				
2003/0067162	A1	4/2003	Welsh et al.				
2003/0193188	A1	10/2003	Miros				
2003/0230894	A1	12/2003	Cleveland et al.				
2004/0021318	A1	2/2004	Fritze et al.				
2004/0056484	A1	3/2004	Kwon et al.				
2004/0094903	A1	5/2004	Sutherland				
2004/0195830	A1	10/2004	Gilmour				
2004/0199143	A1	10/2004	Lauer				
2004/0227346	A1	11/2004	Jamison et al.				
2004/0232696	A1	11/2004	Andre				
2005/0033237	A1	2/2005	Fentress et al.				
2005/0057042	A1	3/2005	Wicks				
2005/0082828	A1	4/2005	Wicks et al.				
2005/0087981	A1	4/2005	Yamada et al.				
2005/0209583	A1	9/2005	Powers et al.				
2005/0217265	A1	10/2005	Popp et al.				
2005/0242579	A1	11/2005	Bright et al.				
2005/0275220	A1	12/2005	Shu				
2006/0066100	A1	3/2006	Nakashima et al.				
2006/0152003	A1	7/2006	Slunick et al.				
2006/0264814	A1	11/2006	Sage				
2006/0293629	A1	12/2006	Cote, Sr. et al.				
2007/0025811	A1	2/2007	Wilhelm				
2007/0029795	A1	2/2007	Moner et al.				
2007/0029796	A1	2/2007	Bibby				
2007/0106213	A1	5/2007	Spera et al.				
2007/0137718	A1	6/2007	Rushlander et al.				
2007/0209716	A1	9/2007	Rankin				
2007/0284875	A1	12/2007	Salomon-Bahls et al.				
2008/0007051	A1*	1/2008	Jensen et al. 285/305				
2008/0011703	A1	1/2008	Schmeisser et al.				
2008/0012314	A1	1/2008	Harger et al.				
2008/0018105	A1	1/2008	Le Bars				
2008/0048448	A1	2/2008	Jamison et al.				
2008/0078464	A1	4/2008	Loewe				
2008/0111371	A1	5/2008	Feger et al.				
2008/0111372	A1	5/2008	Trede et al.				
2008/0129047	A1	6/2008	Blivet et al.				
2008/0164694	A1	7/2008	Zdroik et al.				
2008/0191466	A1	8/2008	Knipple et al.				
2008/0200901	A1	8/2008	Rasmussen et al.				
2008/0277923	A1	11/2008	Brandt et al.				
2008/0277924	A1	11/2008	Jensen et al.				
2008/0284167	A1	11/2008	Lim et al.				

FOREIGN PATENT DOCUMENTS

DE	3533000	3/1987
DE	4122455	1/1993
DE	19800050	7/1998
DE	102005015343	10/2006
EP	0360634	3/1990
EP	0390746	10/1990
EP	0267067	7/1991
EP	0482277	4/1992
EP	0592823	4/1994
EP	0865779	9/1998
EP	0877891	11/1998
EP	0890054	1/1999
EP	0982525	3/2000
EP	1497582	1/2005
EP	1564469	8/2005
EP	1843074	10/2007
FR	2031965	11/1970
FR	2429370	1/1980
FR	280871	10/2001
FR	2853043	10/2004
FR	2870921	12/2005
GB	583459	12/1946
GB	890775	3/1962
GB	2177769	1/1987
GB	2218166	11/1989
GB	2271157	4/1994
GB	2379253	3/2003
JP	53-006918	1/1978
JP	5-223189	8/1993
JP	7-145889	6/1995
JP	10-169869	6/1998
JP	11-82849	3/1999
JP	2003-42363	2/2003
JP	2003-42368	2/2003
WO	WO 93/17270	9/1993
WO	WO 95/08732	3/1995
WO	WO 00/79172	12/2000
WO	WO 2004/104466	12/2004
WO	WO 2005/064216	7/2005
WO	WO 2006/031958	3/2006
WO	WO 2006/073778	7/2006
WO	WO 2006/084171	8/2006
WO	WO 2006/135666	12/2006
WO	WO 2007/038222	4/2007
WO	WO 2007/116387	10/2007
WO	WO 2007/120620	10/2007
WO	WO 2008/023021	2/2008
WO	WO 2009/026441	2/2009

OTHER PUBLICATIONS

Barbed Tee Adapter, 1/2 in to 3/8 in to 1/2 in [Item # F1728], http://www.horticulturesource.com/product_info.php/products_id/4016/ language/en; dated accessed Sep. 14, 2009, 3 pages.

Brochure, "Precision Components", Value Plastics, Inc., 2002, 132 pages.

Capabilities [online], Jay Manufacturing Corp., retrieved on Apr. 9, 2010, retrieved from the Internet: <URL: <http://www.jaymfg.com/capabilities.htm>>, 2 pages.

Flojet "Quick Connect" Port System Adapter 90 Elbow Type Quad Port X 1/2" Hose Barb, http://www.amazon.com/Quick-Connect-Port-System-Quad-Barb-90/dp/B0000AZ771/ref=sr_1_16?s=sporting-goods&ie=UTF8&qid=1300220596&sr=1-16, date accessed Sep. 14, 2009; 3 pages.

High-Flow Quick Disconnect Couplings; http://www.coleparmer.com/catalog/product_view.asp?sku=3130355; date accessed Sep. 14, 2009, 2 pages.

Mills, The Process of Vacuum-forming Plastic Parts, IPFrontline.com [online], retrieved on Apr. 9, 2010, retrieved from the Internet: <URL: <http://www.ipfrontline.com/depts/article.asp?id=453&deptid=2>>, 3 pages.

Nylon, Polypropylene Kynar (PVDF) Plastic Fittings for Flexible Tubing & Hose, http://www.omega.com/pdf/tubing/fittings_tubing_hose/nylon_poly_kynar/nylon.asp; dated accessed Sep. 14, 2009, 2 pages.

Science of Hose Barbs, Colder Products Company, <http://www.pddnet.com/article-the-science-of-hose-barbs/>, date accessed Sep. 4, 2009, 6 pages.

Stackable Hose Barb Elbow—1/2" CTS x 1/2 ID Barb, http://www.freshwatersystems.com/p-1714-stackable-hose-barb-elbow-12-cts-x-12-id-barb.aspx?affiliated=10052&utm_source=shopzilla&utm_medium=Feed&utm_campaign=Product&utm_term=3512-1008, date accessed Sep. 14, 2009, 1 page.

Stainless Steel Overview: History [online], Stainless Steel Industry of North America, retrieved on Apr. 9, 2010, retrieved from the Internet: <URL: <http://www.ssina.com/overview/history.html>>, 1 page.

* cited by examiner

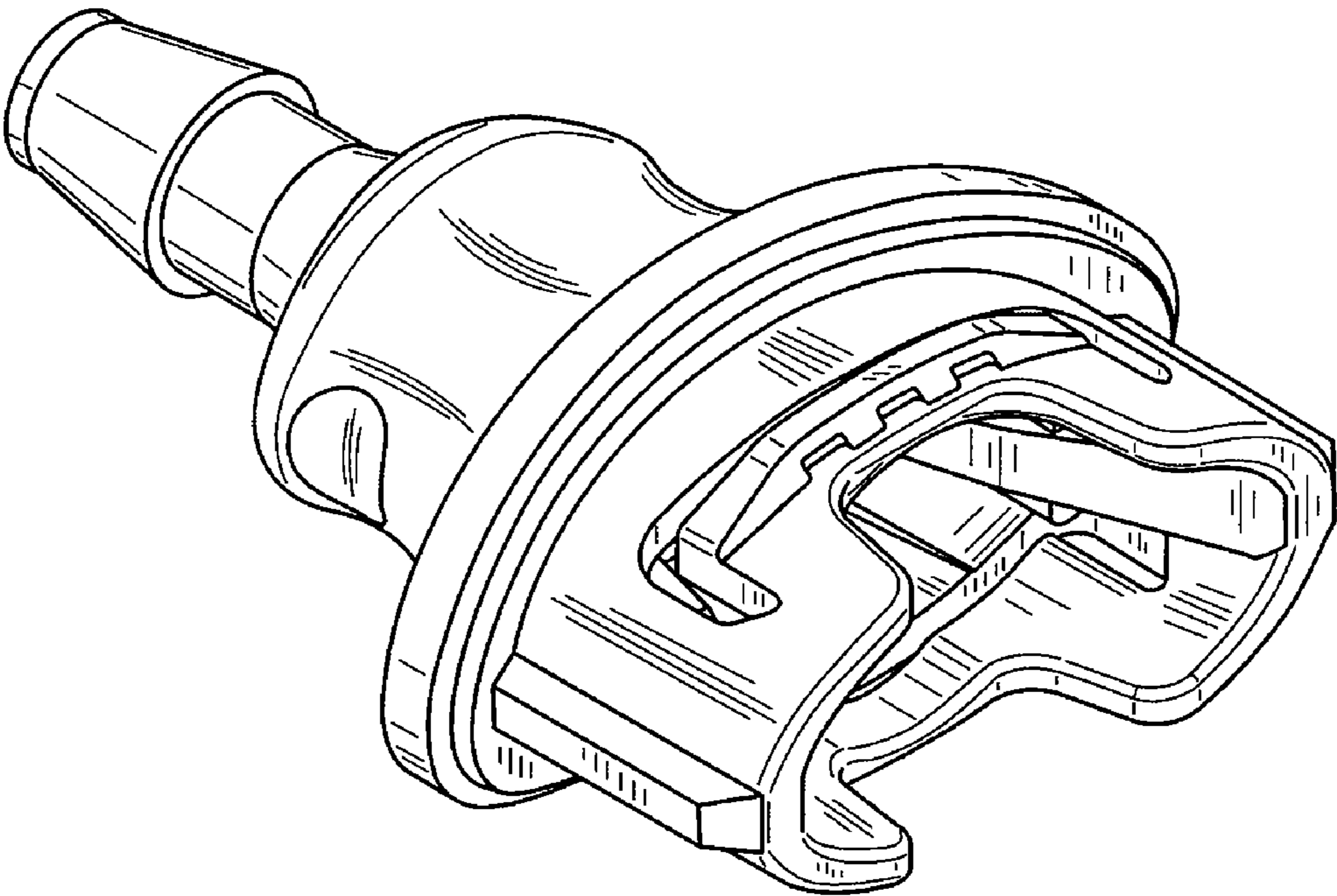

FIG. 1

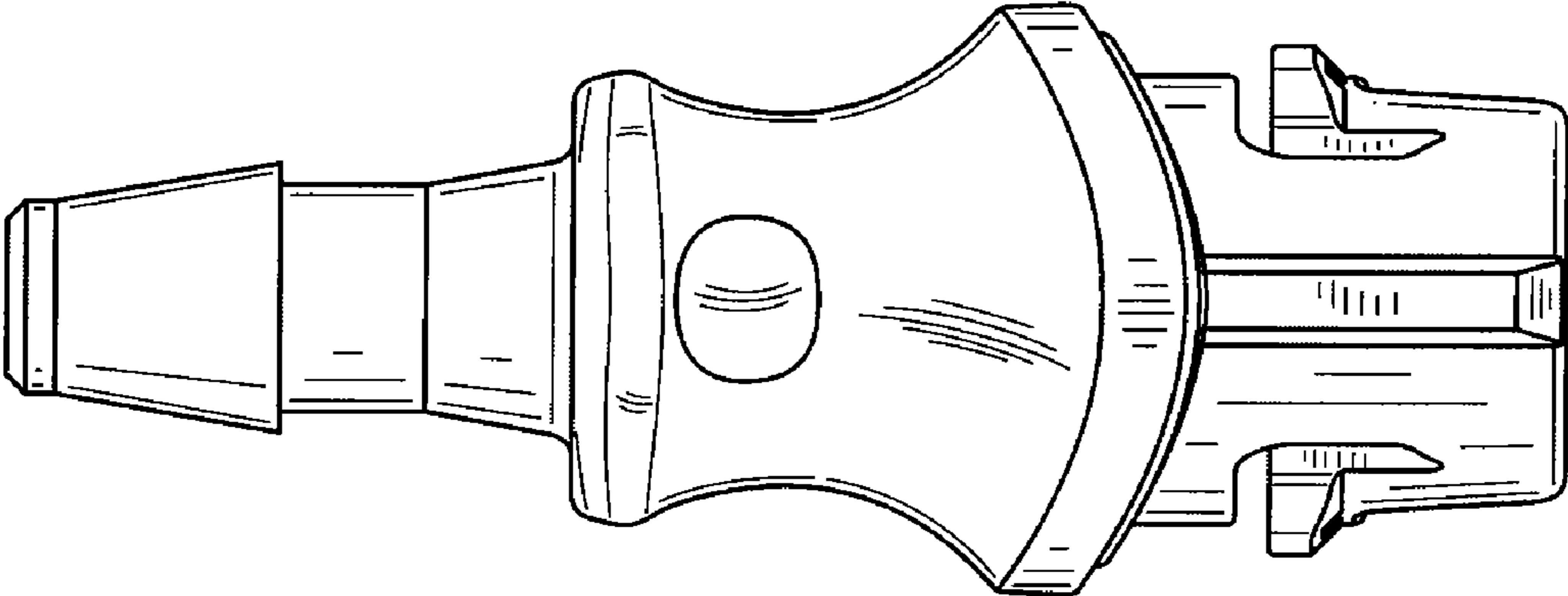

FIG. 2

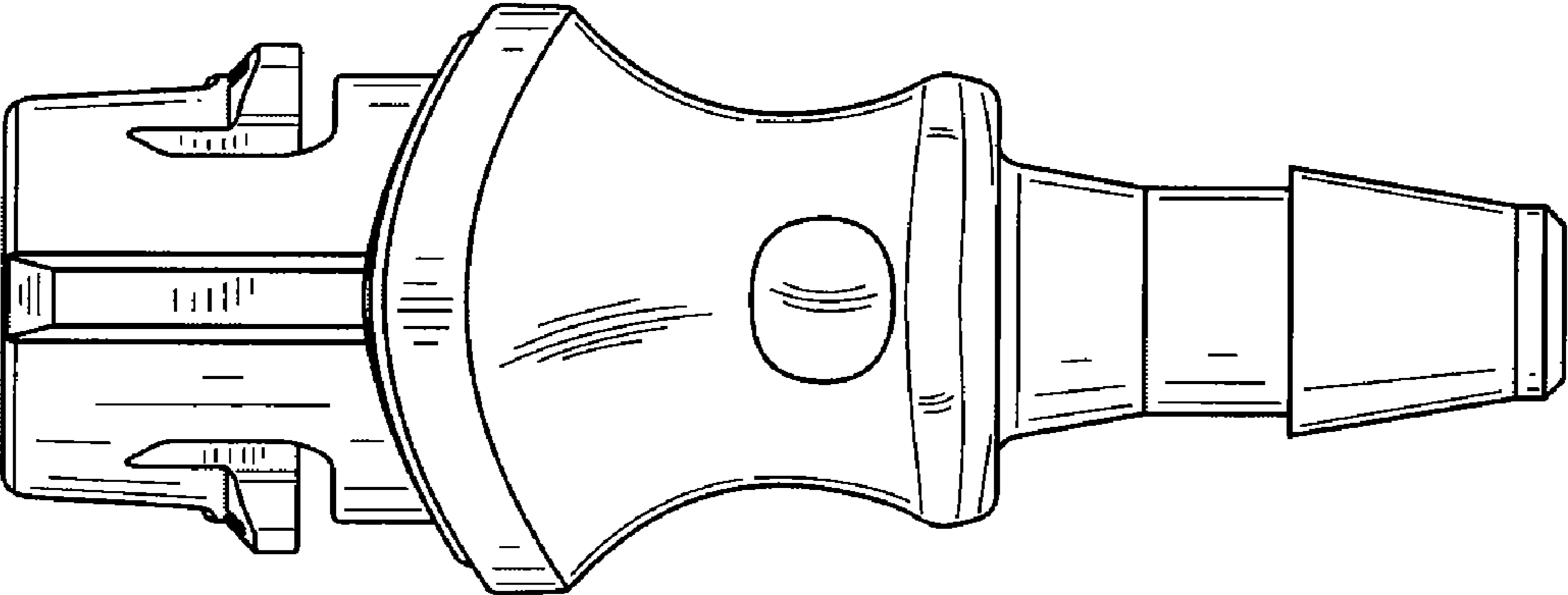

FIG. 3

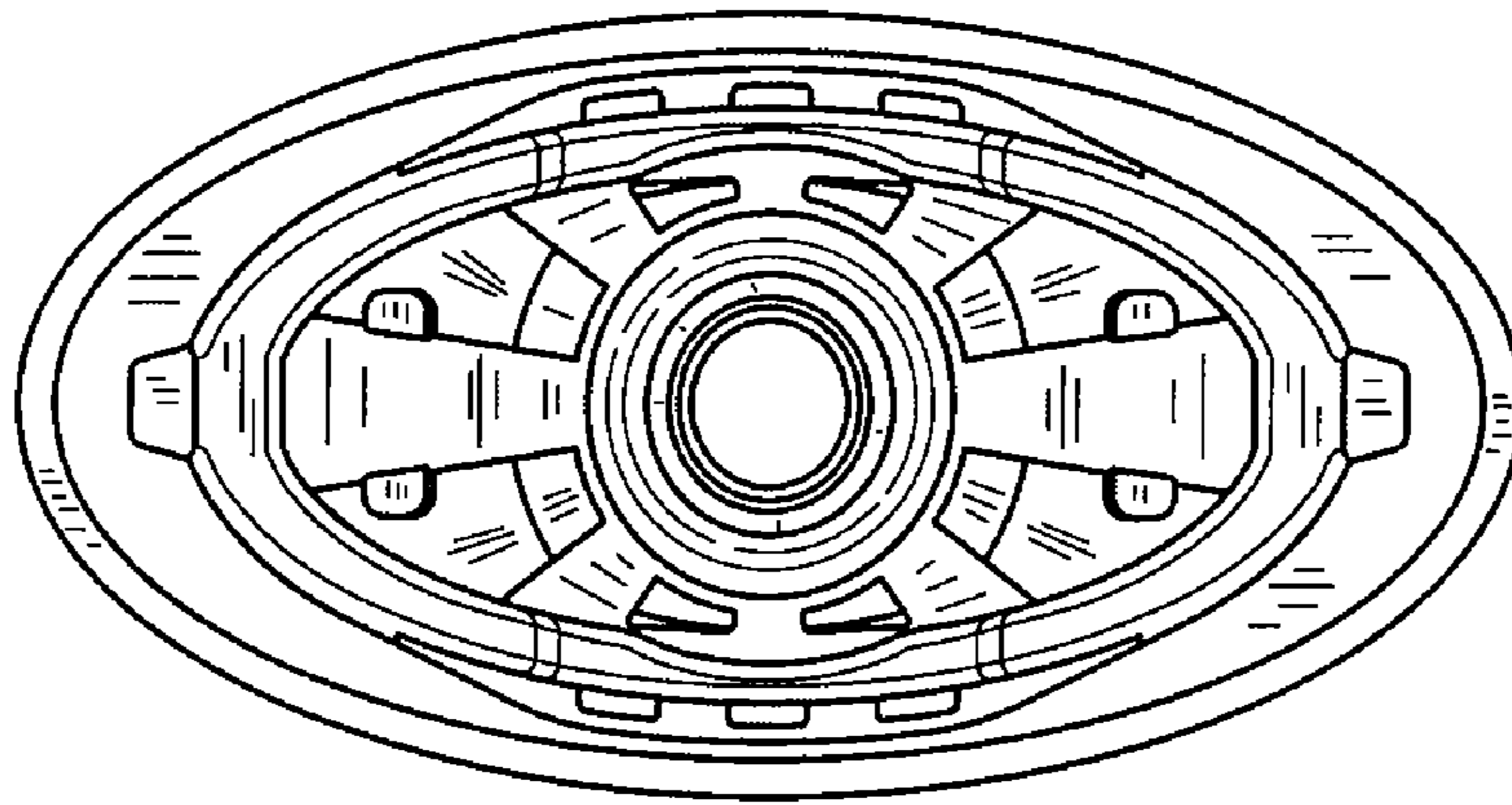

FIG.4

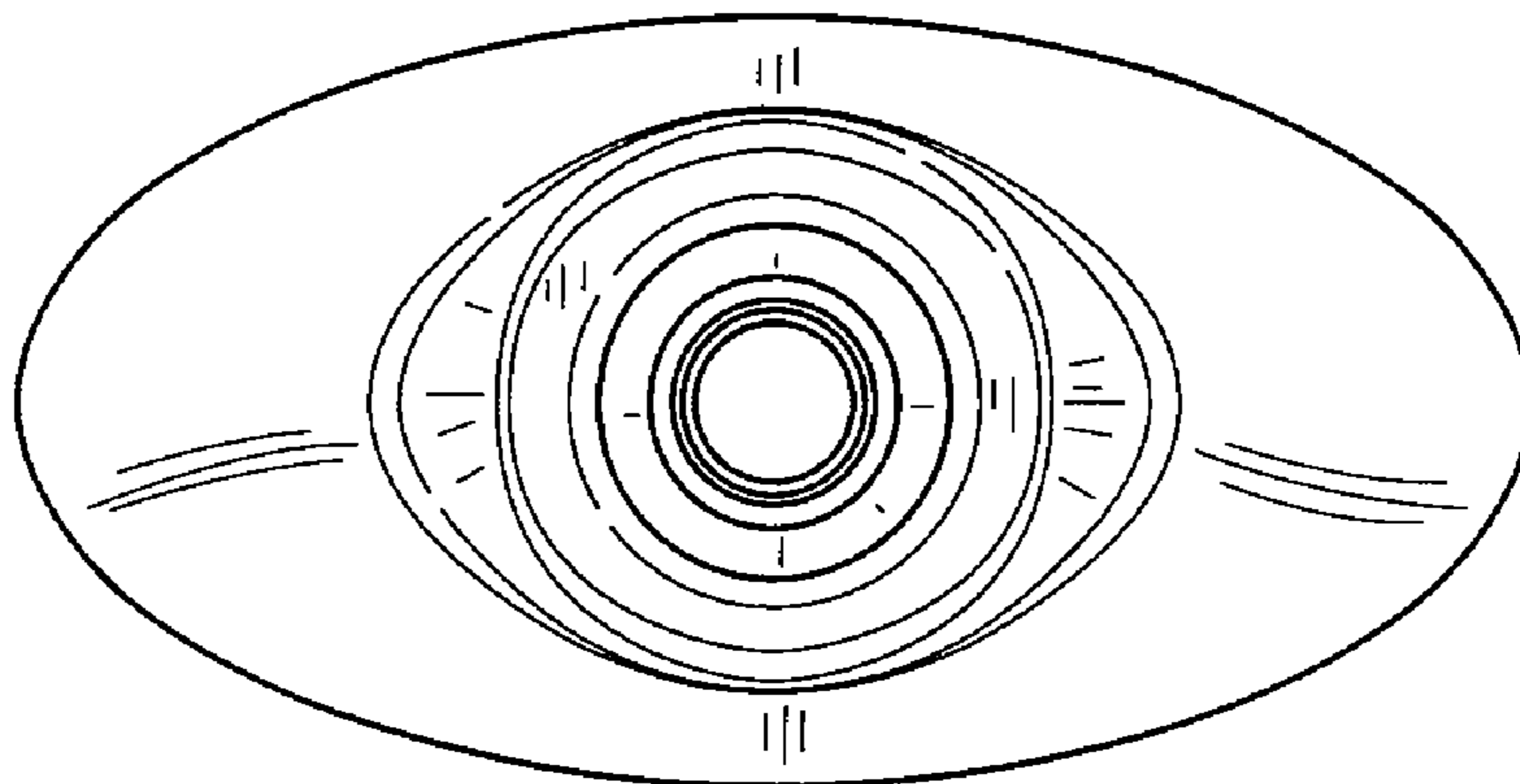

FIG.5

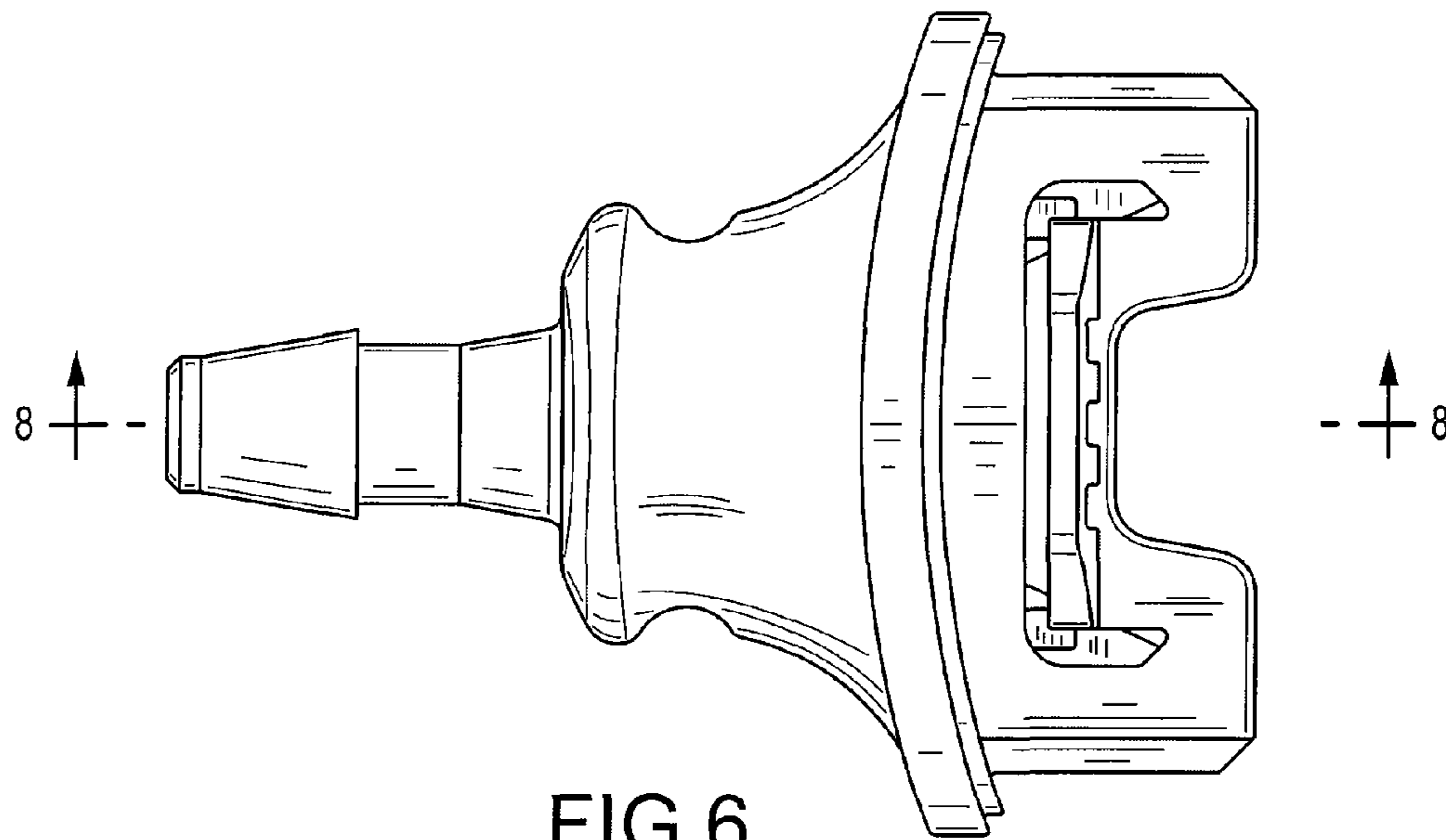

FIG. 6

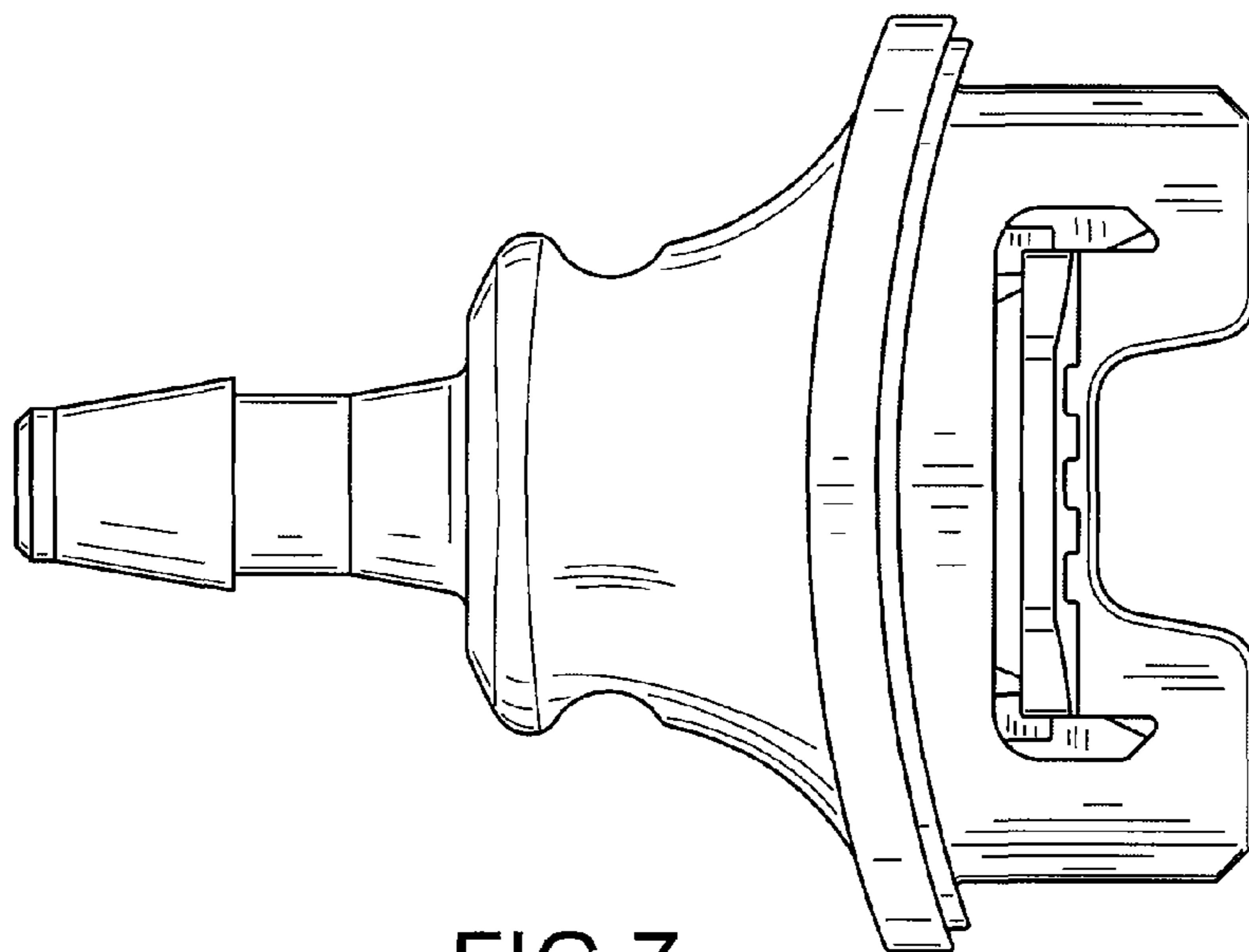

FIG. 7

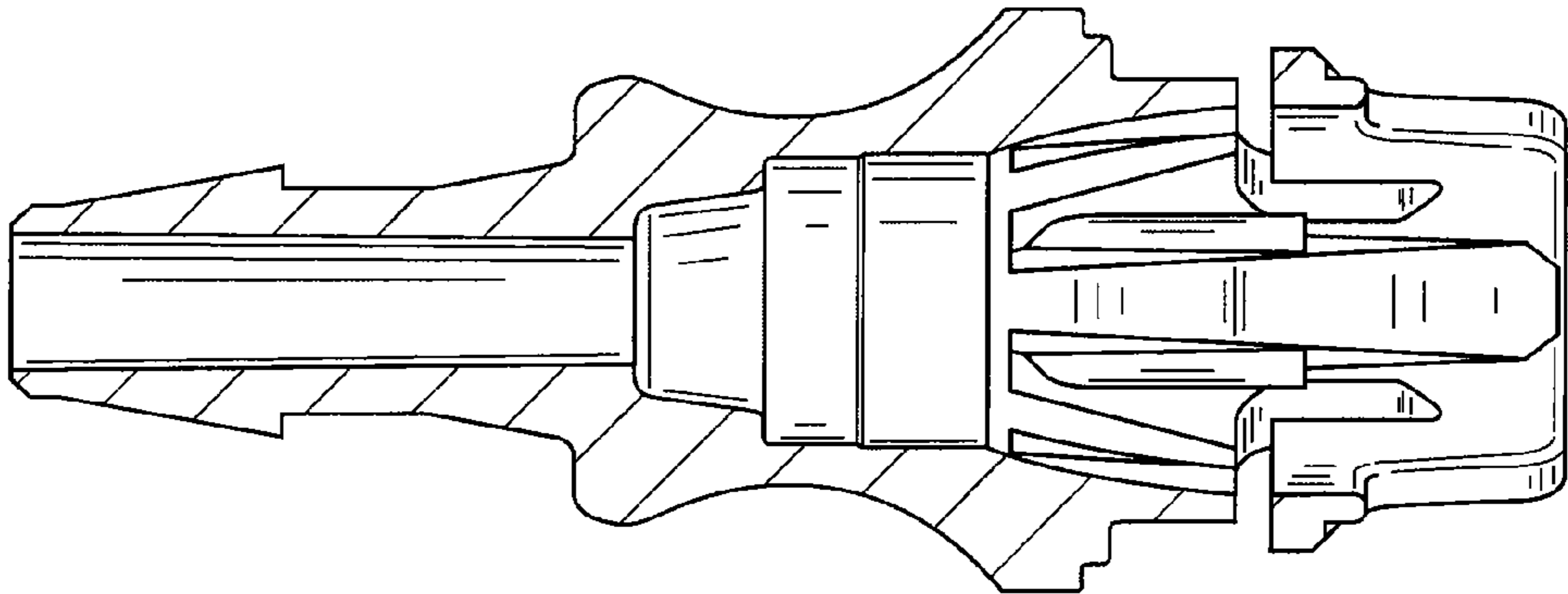

FIG.8